

### GENERAL DESCRIPTION

HT2811H is high performance primary sensing regulator (PSR) and monolithic switch power controller which is designed for small-power supply equipment with current mode control. Built-in accurate CV/CC control circuit, eliminates optocoupler, TL431 and its related loop devices. High integration design, a high performance power BJT and PFM controller and all kinds of protection circuits in one chip, to minimize the peripheral components to save the cost greatly. HT2811H can be simply designed a typical flyback switch converter, the unique driving technology promotes the characteristics of withstand voltage and achieves excellent converting efficiency

- ◆ PSR control, eliminates optocoupler and TL431;
- ◆ Accurate CV/CC control
- ◆ Hysteresis over-temperature protection (OTP) circuit
- ◆ Higher efficiency and meet Level 6 efficiency standards
- ◆ Output voltage protection (OVP/UVP)
- ◆ < 100 mW no-load consumption
- ◆ Auto-Restart function
- ◆ Ultra-low start-up current
- ◆ Good EMC characteristic allows the simple EMC circuit

### FEATURES

- ◆ Built-in 800V power BJT;

### APPLICATIONS

- ◆ Intelligent mobile phone/small size tablet computer
- ◆ Digital cameras and other small digital products
- ◆ Power adapters for network products etc
- ◆ RCC solutions Replace

### APPLICATION CIRCUIT

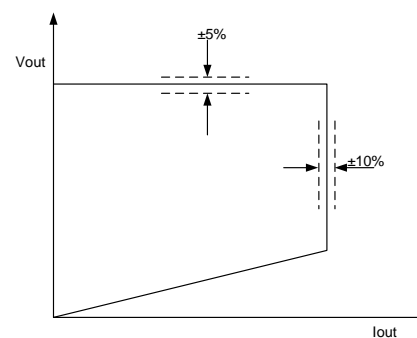
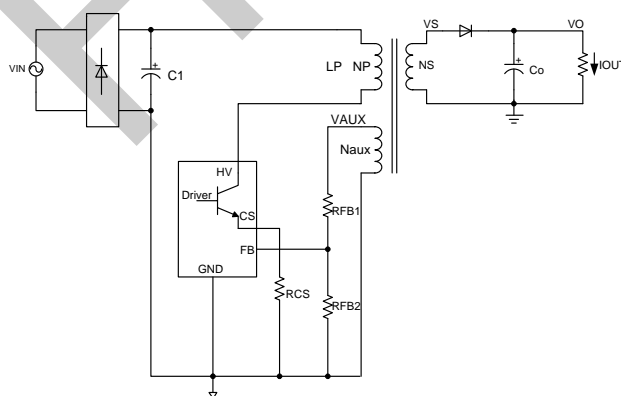

### PIN DEFINITION

SOP5	Pin Name	Pin #	Description
	VCC	1	Power supplying pin of the controller, In order to let the controller gain more Stable supply voltage, the external filter capacitor must use low equivalent impedance (Low ESR) of the electrolytic capacitor.
	FB	2	Output feedback pin, to detect the output condition through the auxiliary winding voltage of the transformer
	CS	3	Connect external primary current sensing resistor RCS, the controller can detect the primary current through the external sense resistor. When the voltage on the resistor achieves the maximum value, the internal power BJT will be turn off immediately
	HV	4	To connect the collector of internal power BJT
	GND	5	The referring grounding pin of the controller

### FUNCTIONAL BLOCK DIAGRAM

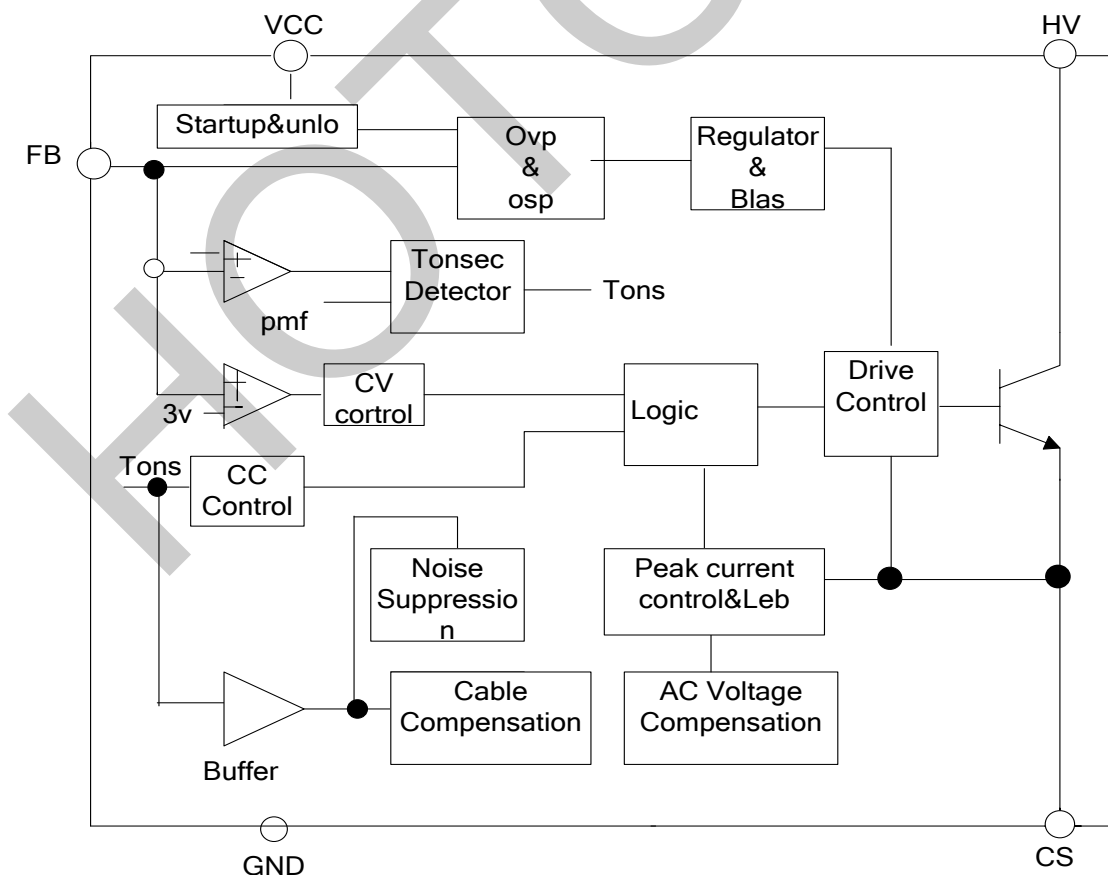

**ABSOLUTE MAXIMUM RATINGS**

Internal power BJT Vcbo	800V
BJT Ic Peak Current:	1.3A
VCC Pin Voltage	8.6V
FB Pin Voltage	7V
Others Pin Voltage	Vcc+0.3V
Operating Temperature (Tj)	0~+140°C
Storage Temperature	-55~+150°C
Lead Temperature	+260°C/10S

## Notes:

- 1.All voltages referred to Ic GND (TA=25°C),
2. Duration not exceed 2 msec.
- 3.Instant maximum ratings specified will not cause permanent damage To the product, while long maximum ratings specified applied will do And may affect product reliability.

### ELECTRICAL CHARACTERISTICS (Unless otherwise specified, parameters are measured by setting GND Potential as zero Potential in room Temp.)

Parameter	Symbol	Conditions	Min	Type	Max	Unit
VCC UVLO						
Star-up Voltage	VCC-ON		7.5	8.0	8.8	V
Shut down	VCC OFF		3.0	3.3	3.5	V
Star-up Current	IStar			0.2	1	uA
Operating Current	ICC	Static current		400	500	uA
Max. Operating Voltage	VCC-MAX				8.5v	
CURRENT SENSE SECTION						
Maximum Current to CS PIN	ICS		3.4	4	5	uA
Current Sense Threshold Voltage	VCS				510	mV
Leading Edge Blanking	TLEB	Ic=1mA		500		nS
FEED BACK INPUT SECTION						
FB Reference Voltage	VREF-FB		2.85	2.9	2.95	V
Input Resistance of FB Pin	RFB		1.2	1.5	2	MΩ
Feedback Threshold Voltage	VFB-MAX				5	V
POWER BJT SECTION						
Collector-emitter Saturation Voltage	VCE sat	Ic=500mA Ib=100mA			0.5	V
Collector-Base Voltage	VCBO		800			V
OVER TEMPERATURE PROTECTION(OTP)						
Shutdown Temperature	TSHDN		135	140	145	°C
Temperature Hysteresis	THYS		125	130	135	°C

**FUNCTION DESCRIPTION**

HT2811H is specially designed for the charger/adaptor of small power digital products. To use PSR control technology to provide accurate (CV/CC) characteristics. The controller works in PFM mode and the switching frequency can be automatically adjusted as per the load. Optimized driving circuit greatly promotes withstand voltage of the power BJT and minimizes the switching loss, so as to make the circuit have excellent converting efficiency

**CONSTANT VOLTAGE(CV) OPERATION**

When the circuit is operates in CV area, FB will detect the output voltage when the power BJT turn-off through the sensing voltage by auxiliary winding of the transformer, to make the output voltage stablized in the fixed value. In the turn-on period of the output rectifier diode D, it's given the output winding voltage and auxiliary winding voltage as follows

$$V_{AUX} = \frac{N_{AUX}}{N_s} \cdot (V_o + V_d) \text{ -----(5)}$$

Vaux : auxiliary winding voltage; Nb: subsidiary winding turns; NS: output winding turns; Vd: forward voltage drop of output rectifier diode

FB will test the auxiliary winding voltage while the power BJT off-time to regulate the output voltage. In order to avoid the peak influence happens in power BJT turn-off resulting from the leakage inductance of the transformer, and considering the accuracy of sampling voltage, FB captures the auxiliary winding detection sampling points as below:

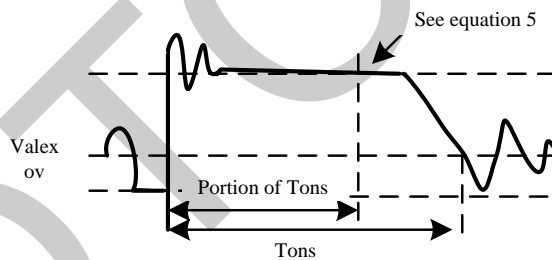

**CONSTANT CURRENT(CC ) OPETATION**

HT2811H CC control circuit is requested the converter operating in DCM . In CC operation mode , the CC control circuit will fix the proportion between the Tons and Toffs produced by diode rectifier D. When Tons time, the primary energy of the transformer will be converted to the secondary winding, via the rectifier diode then charge the output capacitor and supply load simultaneously.

When Toffs, the primary coil stores the energy, the output filter capacitor makes load discharge. In CC operation area, HT2811H switch frequency will follow the output load direct ratio contro detected by FB Voltage

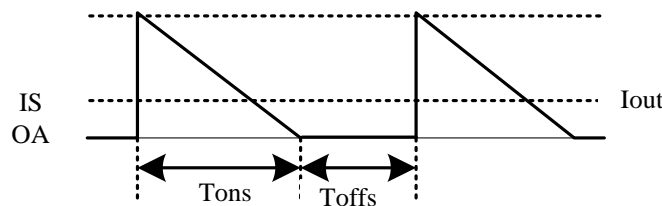

The secondary rectifier diode peak current is determined by the peak current of primary-side inductance which also affects the output current. The corresponding relation between the primary peak current and the secondary peak current is as follows

$$I_{pks} = \frac{N_p}{N_s} \cdot I_{pk}$$

$I_{pk}$ : primary peak current ;  $N_p$ : primary winding turns;  $N_s$ : secondary winding turns;  
 $I_{pks}$ : secondary peak current

And primary inductance peak current is determined by Pin 4 to RCS resistance, the primary inductance peak current and RCS resistance are in inverse proportion, so only need to adjust CS resistance to achieve different output currents. Output current  $I_{out}$  and primary current are given by

$$I_{out} = \frac{1}{2} \cdot I_{pks} \cdot \frac{T_{ons}}{T_{ons} + T_{offs}}$$

$I_{out}$ : Output current;  $T_{ons}$ : secondary rectifier diode on-time;  $T_{offs}$ : secondary rectifier diode off-time

## OUTPUT CABLE COMPENSATION

HT2811H built-in output cable drop compensation circuit. When it outputs different loads, the cable drop compensation circuit provides cable drop voltage compensation which is in fixed proportion with output voltage.

## PROTECTIVE FUNCTIONS

In order to guarantee a safe and reliable circuit to all occasions, HT2811H built-in rich protection circuits, such as OCP, OVP, FB open-loop protection etc. as intergration. Once abnormality, it will come into protection mode

## TYPICAL APPLICATION CIRCUIT

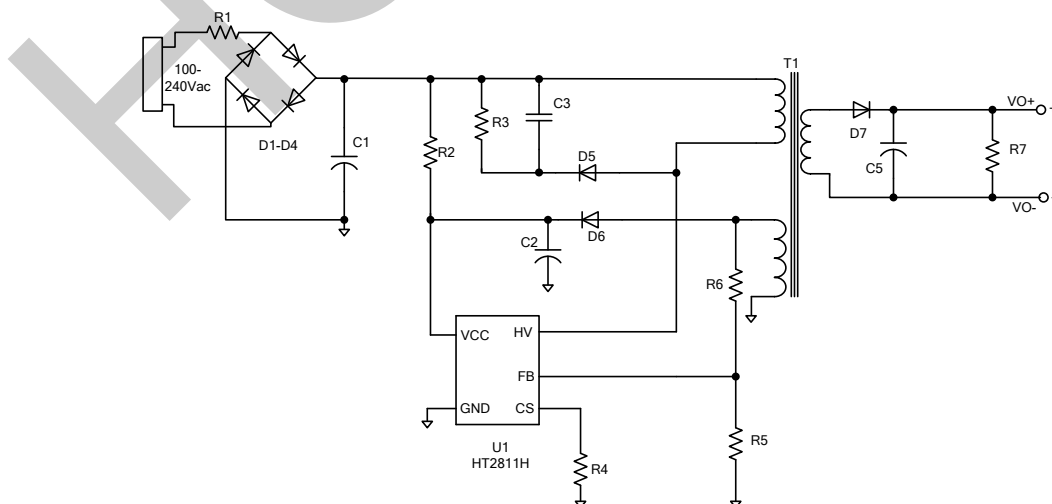

Typical application of HT2811H for RCC replace (Output: 5V/1.0A)

**Packaging Information**

## SOP5 Package

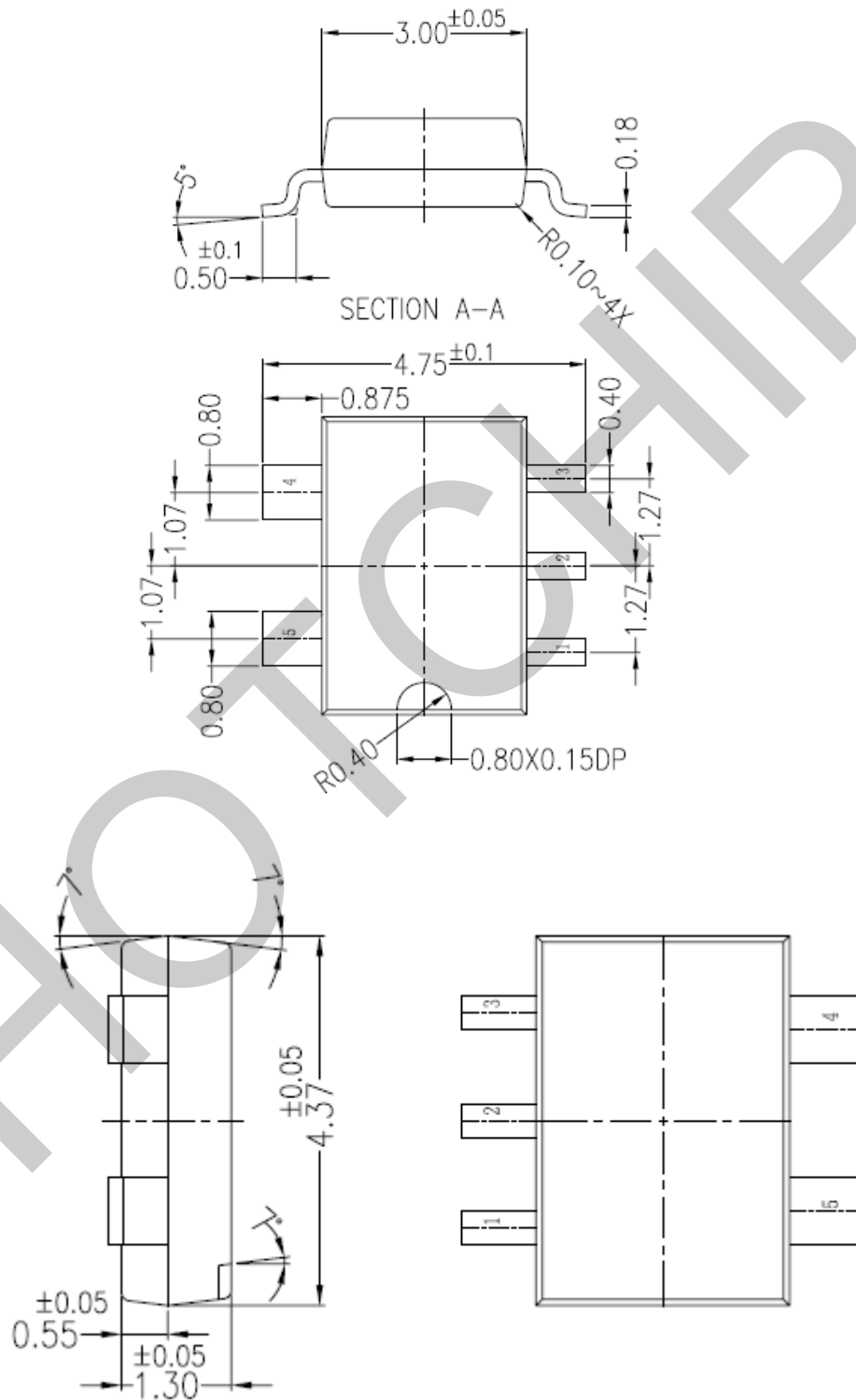

**PACKAGE DESCRIPTION**

## Device Marking and Ordering Information

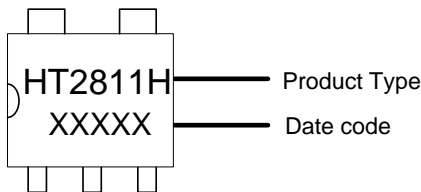

Package	Chip surface marking	Purchasing the device name
SOP5 Pb-free	HT2811H	HT2811H

**IMPORTANT NOTICE**

- ✧ HOTCHIP reserves the right to alter its products without prior notification. For the most up-to-date information, please visit our web site at <http://www.hotchip.com.cn>.
- ✧ HOTCHIP assumes no liability for the issues about the industrial standard, licenses and the right of the third party caused by the electric circuit and chart. The schematic is just for typical application, is not for the specialized mass production application.
- ✧ The export authorization from government is needed when the product or its derivative product do not agree with the Wassenaar Arrangement or other international agreement.
- ✧ Any copy of these information without our permission to print for other uses is forbidden.
- ✧ HOTCHIP's products are not authorized for use as critical components in life support devices or systems, such as motion machine, medical machine, security system, gas equipment, airplane or any other conveyance.
- ✧ HOTCHIP cannot avoid fault or losing efficacy, though we will do the best to improve the quality and reliability. The customers use the products should go through the security design, such as the redundant design, fire protection design, failure protection about the secondary disasters, fire or other related damage.
- ✧ HOTCHIP will continuously provide better products for the customers by all our heart