

## 1.5 A, Adjustable Output, Negative Voltage Regulator

The HT337 is an adjustable 3-terminal negative voltage regulator capable of supplying in excess of 1.5 A over an output voltage range of -1.2 V to -37 V. This voltage regulator is exceptionally easy to use and requires only two external resistors to set the output voltage. Further, it employs internal current limiting, thermal shutdown and safe area compensation, making it essentially blow-out proof.

The HT337 serves a wide variety of applications including local, on card regulation. This device can also be used to make a programmable output regulator, or by connecting a fixed resistor between the adjustment and output, the HT337 can be used as a precision current regulator.

### Features

- Output Current in Excess of 1.5 A
- Output Adjustable between -1.2 V and -37 V
- Internal Thermal Overload Protection
- Internal Short Circuit Current Limiting Constant with Temperature
- Output Transistor Safe-Area Compensation
- Floating Operation for High Voltage Applications
- Eliminates Stocking many Fixed Voltages
- Available in Surface Mount D<sup>2</sup>PAK and Standard 3-Lead Transistor Package
- These Devices are Pb-Free and are RoHS Compliant

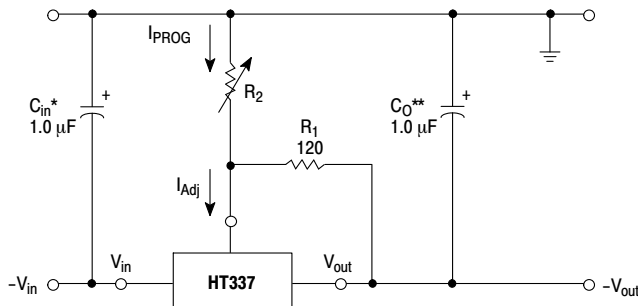

\*C<sub>in</sub> is required if regulator is located more than 4 inches from power supply filter. A 1.0 µF solid tantalum or 10 µF aluminum electrolytic is recommended.

\*\*C<sub>O</sub> is necessary for stability. A 1.0 µF solid tantalum or 10 µF aluminum electrolytic is recommended.

$$V_{out} = -1.25 V \left( 1 + \frac{R_2}{R_1} \right)$$

Figure 1. Standard Application

### PIN CONNECTIONS

- Pin 1. V<sub>in</sub>  
 2. V<sub>out</sub>  
 3. V<sub>out</sub>  
 4. Adjust  
 5. N.C.  
 6. V<sub>out</sub>  
 7. V<sub>out</sub>  
 8. N.C.



**ESOP8 E**  
**SUFFIX**  
**HT337AREZ**



**SOT223 D**  
**SUFFIX**  
**HT337ARDZ**



**TO252 M**  
**SUFFIX**  
**HT337ARMZ**

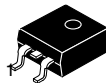

**TO263 S**  
**SUFFIX**  
**HT337ARSZ**

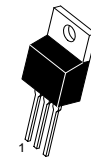

**TO220 T**  
**SUFFIX**  
**HT337ATZ**

- Pin 1. Adjust  
 2. V<sub>in</sub>  
 3. V<sub>out</sub>

Heatsink tab is connected to Pin 2.

T<sub>A</sub> = -40° to 125°C for all packages

**MAXIMUM RATINGS** ( $T_A = +25^\circ\text{C}$ , unless otherwise noted)

Rating	Symbol	Value	Unit
Input–Output Voltage Differential	$V_I - V_O$	40	Vdc
Power Dissipation Case 221A $T_A = +25^\circ\text{C}$ Thermal Resistance, Junction–to–Ambient Thermal Resistance, Junction–to–Case Case 936 (D <sup>2</sup> PAK) $T_A = +25^\circ\text{C}$ Thermal Resistance, Junction–to–Ambient Thermal Resistance, Junction–to–Case	$P_D$ $\theta_{JA}$ $\theta_{JC}$ $P_D$ $\theta_{JA}$ $\theta_{JC}$	Internally Limited 65 5.0 Internally Limited 70 5.0	W $^\circ\text{C}/\text{W}$ $^\circ\text{C}/\text{W}$ W $^\circ\text{C}/\text{W}$ $^\circ\text{C}/\text{W}$
Operating Junction Temperature Range	$T_J$	–40 to +125	$^\circ\text{C}$
Storage Temperature Range	$T_{stg}$	–65 to +150	$^\circ\text{C}$

Stresses exceeding those listed in the Maximum Ratings table may damage the device. If any of these limits are exceeded, device functionality should not be assumed, damage may occur and reliability may be affected.

**ELECTRICAL CHARACTERISTICS** ( $|V_I - V_O| = 5.0\text{ V}$ ;  $I_O = 0.5\text{ A}$  for T package;;  $I_{max}$  and  $P_{max}$  [Note 1].)

Characteristics	Figure	Symbol	Min	Typ	Max	Unit
Line Regulation (Note 3), $T_A = +25^\circ\text{C}$ , $3.0\text{ V} \leq  V_I - V_O  \leq 40\text{ V}$	1	$\text{Reg}_{line}$	–	0.01	0.04	%/V
Load Regulation (Note 3), $T_A = +25^\circ\text{C}$ , $10\text{ mA} \leq I_O \leq I_{max}$ $ V_O  \leq 5.0\text{ V}$ $ V_O  \geq 5.0\text{ V}$	2	$\text{Reg}_{load}$	– –	15 0.3	50 1.0	mV % $V_O$
Thermal Regulation, $T_A = +25^\circ\text{C}$ (Note 5), 10 ms Pulse		$\text{Reg}_{therm}$	–	0.003	0.04	% $V_O/\text{W}$
Adjustment Pin Current	3	$I_{Adj}$	–	65	100	$\mu\text{A}$
Adjustment Pin Current Change, $2.5\text{ V} \leq  V_I - V_O  \leq 40\text{ V}$ , $10\text{ mA} \leq I_L \leq I_{max}$ , $P_D \leq P_{max}$ , $T_A = +25^\circ\text{C}$	1, 2	$\Delta I_{Adj}$	–	2.0	5.0	$\mu\text{A}$
Reference Voltage, $T_A = +25^\circ\text{C}$ , $3.0\text{ V} \leq  V_I - V_O  \leq 40\text{ V}$ , $10\text{ mA} \leq I_O \leq I_{max}$ , $P_D \leq P_{max}$ , $T_J = T_{low}$ to $T_{high}$	3	$V_{ref}$	–1.213 –1.20	–1.250 –1.25	–1.287 –1.30	V
Line Regulation (Note 3), $3.0\text{ V} \leq  V_I - V_O  \leq 40\text{ V}$	1	$\text{Reg}_{line}$	–	0.02	0.07	%/V
Load Regulation (Note 3), $10\text{ mA} \leq I_O \leq I_{max}$ $ V_O  \leq 5.0\text{ V}$ $ V_O  \geq 5.0\text{ V}$	2	$\text{Reg}_{load}$	– –	20 0.3	70 1.5	mV % $V_O$
Temperature Stability ( $T_{low} \leq T_J \leq T_{high}$ )	3	$T_S$	–	0.6	–	% $V_O$
Minimum Load Current to Maintain Regulation ( $ V_I - V_O  \leq 10\text{ V}$ ) ( $ V_I - V_O  \leq 40\text{ V}$ )	3	$I_{Lmin}$	– –	1.5 2.5	6.0 10	mA
Maximum Output Current $ V_I - V_O  \leq 15\text{ V}$ , $P_D \leq P_{max}$ , T Package $ V_I - V_O  \leq 40\text{ V}$ , $P_D \leq P_{max}$ , $T_J = +25^\circ\text{C}$ , T Package	3	$I_{max}$	– –	1.5 0.15	2.2 0.4	A
RMS Noise, % of $V_O$ , $T_A = +25^\circ\text{C}$ , $10\text{ Hz} \leq f \leq 10\text{ kHz}$		N	–	0.003	–	% $V_O$
Ripple Rejection, $V_O = -10\text{ V}$ , $f = 120\text{ Hz}$ (Note 4) Without $C_{Adj}$ $C_{Adj} = 10\text{ }\mu\text{F}$	4	RR	– 66	60 77	– –	dB
Long–Term Stability, $T_J = T_{high}$ (Note 6), $T_A = +25^\circ\text{C}$ for Endpoint Measurements	3	S	–	0.3	1.0	%/1.0 k Hrs.
Thermal Resistance, Junction–to–Case, T Package		$R_{\theta JC}$	–	4.0	–	$^\circ\text{C}/\text{W}$

Product parametric performance is indicated in the Electrical Characteristics for the listed test conditions, unless otherwise noted. Product performance may not be indicated by the Electrical Characteristics if operated under different conditions.

- $I_{max} = 1.5\text{ A}$ ,  $P_{max} = 20\text{ W}$
- Load and line regulation are specified at constant junction temperature. Change in  $V_O$  because of heating effects is covered under the Thermal Regulation specification. Pulse testing with a low duty cycle is used.
- $C_{Adj}$ , when used, is connected between the adjustment pin and ground.
- Power dissipation within an IC voltage regulator produces a temperature gradient on the die, affecting individual IC components on the die. These effects can be minimized by proper integrated circuit design and layout techniques. Thermal Regulation is the effect of these temperature gradients on the output voltage and is expressed in percentage of output change per watt of power change in a specified time.
- Since Long Term Stability cannot be measured on each device before shipment, this specification is an engineering estimate of average stability from lot to lot.

**Representative Schematic Diagram**

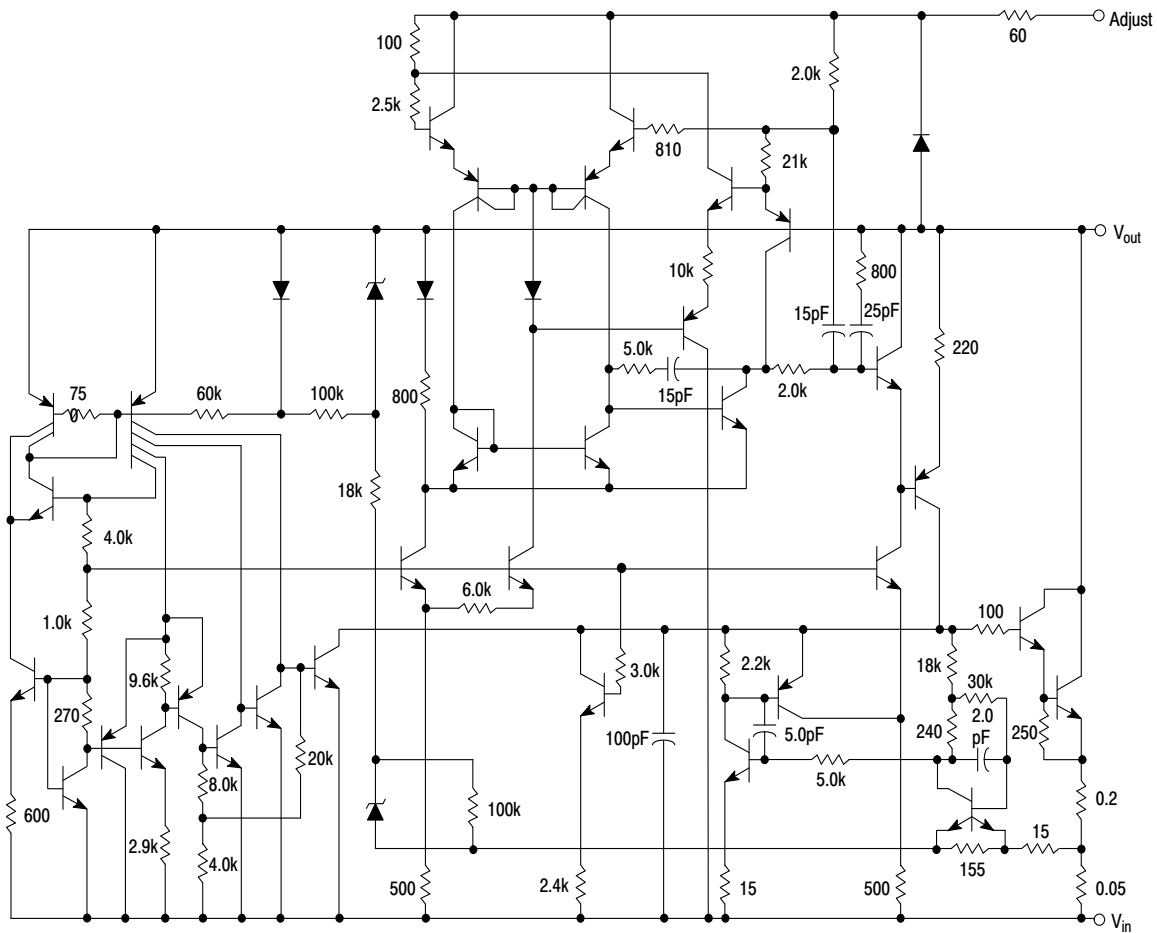

This device contains 39 active transistors.

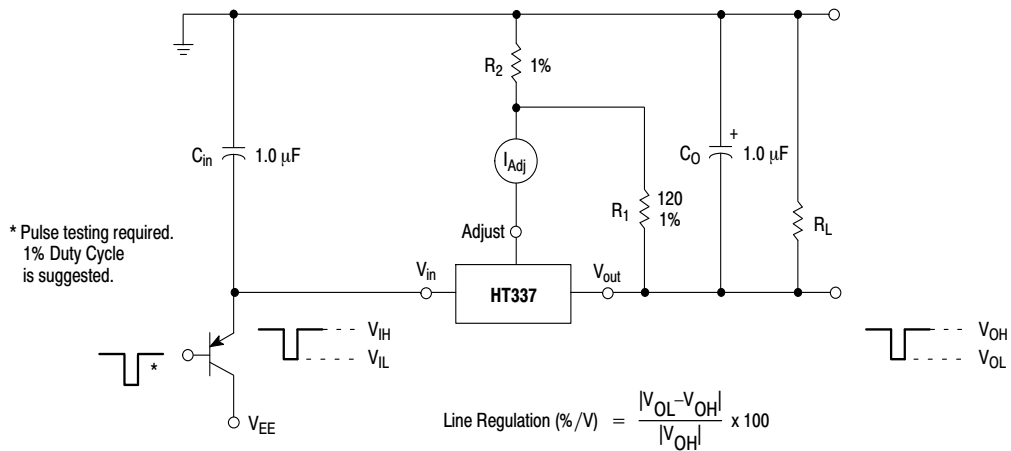

**Figure 1. Line Regulation and  $\Delta I_{Adj}$ /Line Test Circuit**

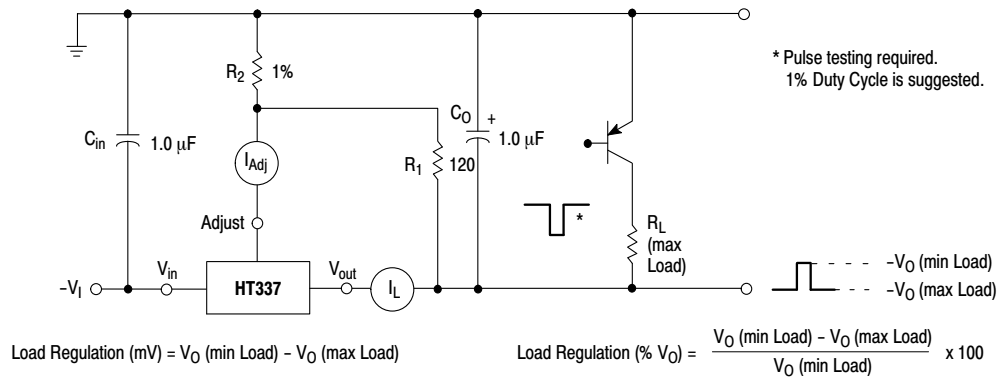

**Figure 2. Load Regulation and  $\Delta I_{Adj}$ /Load Test Circuit**

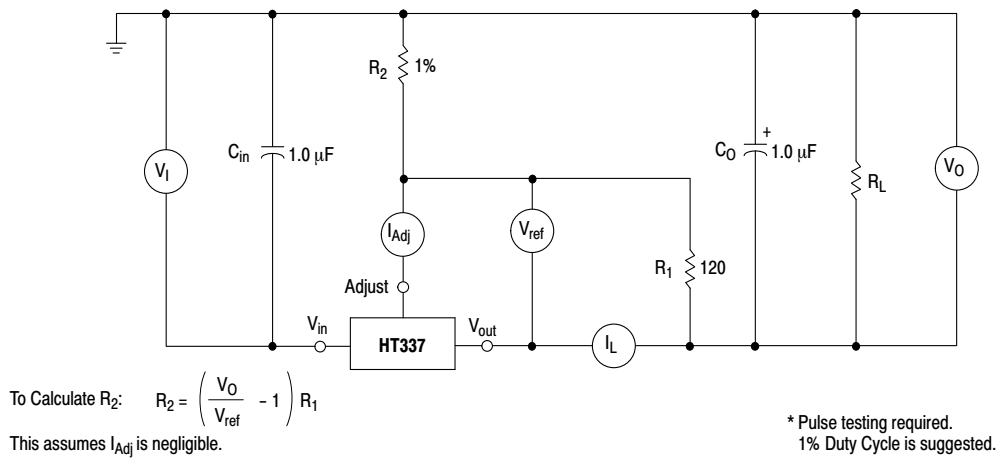

**Figure 3. Standard Test Circuit**

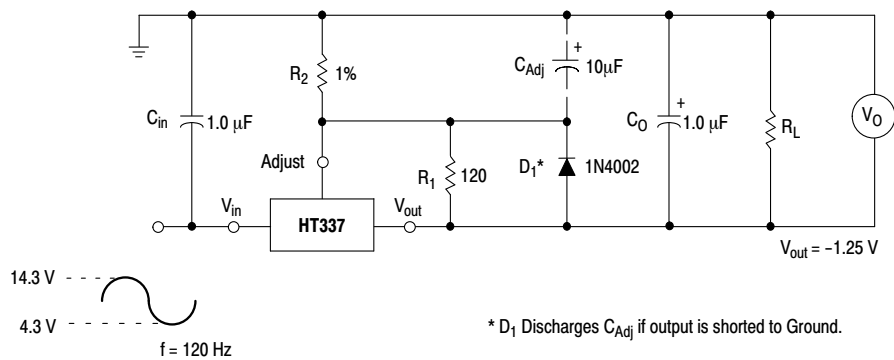

**Figure 4. Ripple Rejection Test Circuit**

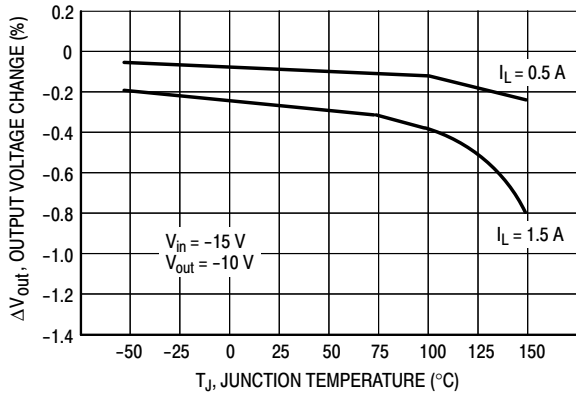

**Figure 5. Load Regulation**

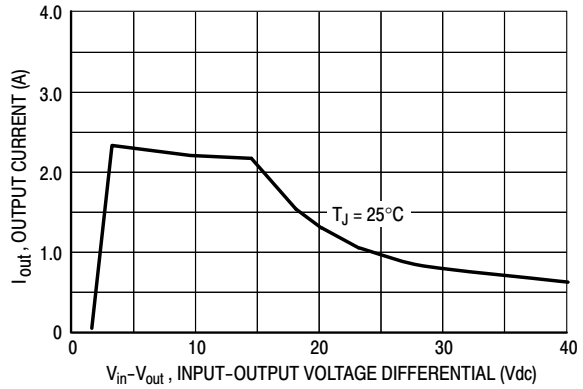

**Figure 6. Current Limit**

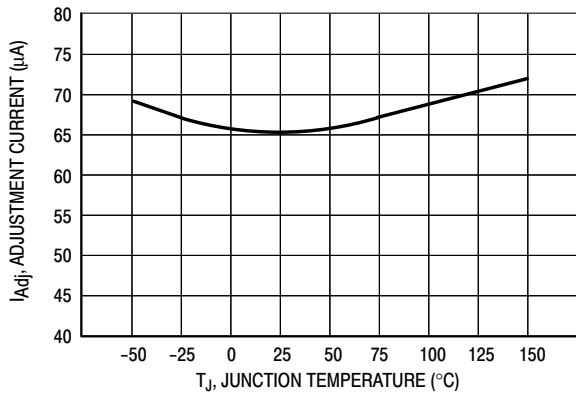

**Figure 7. Adjustment Pin Current**

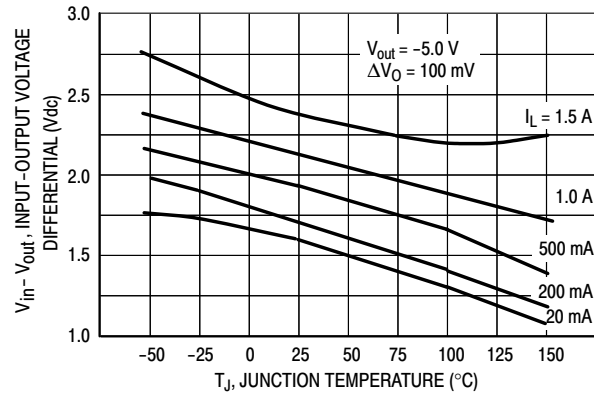

**Figure 8. Dropout Voltage**

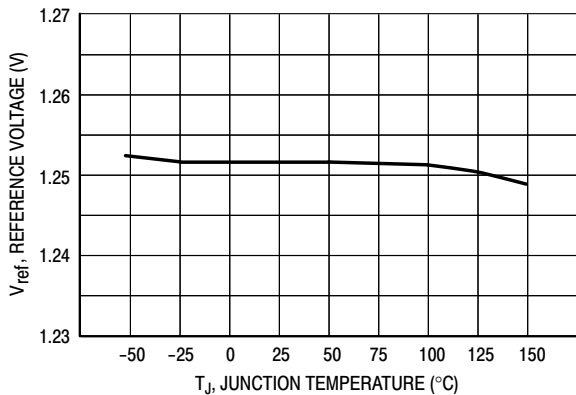

**Figure 9. Temperature Stability**

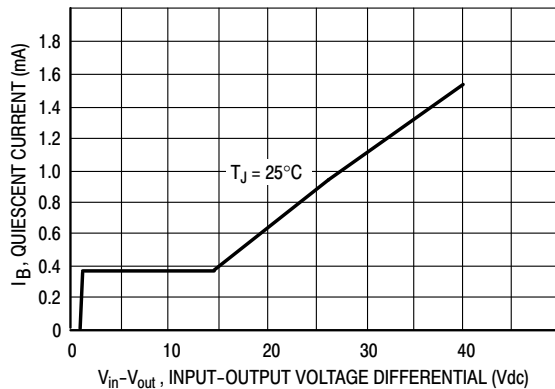

**Figure 10. Minimum Operating Current**

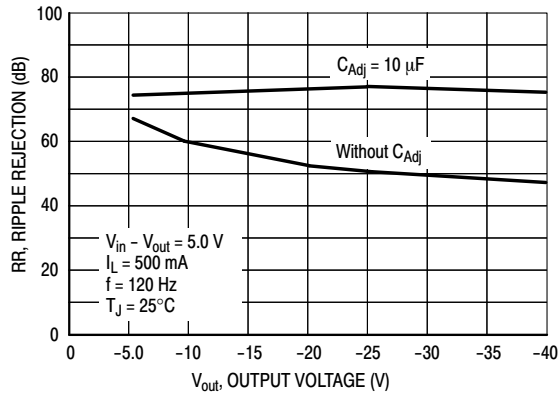
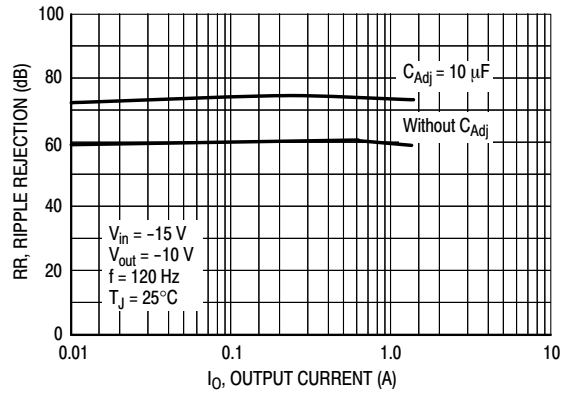
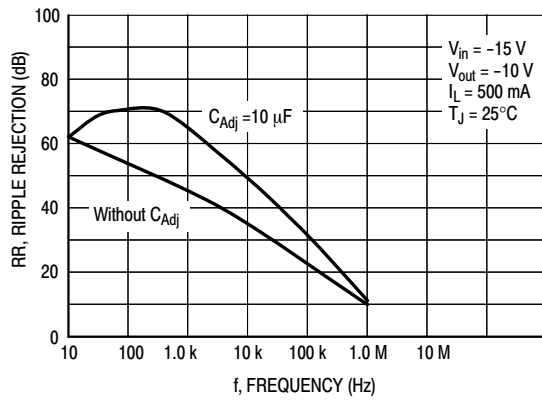
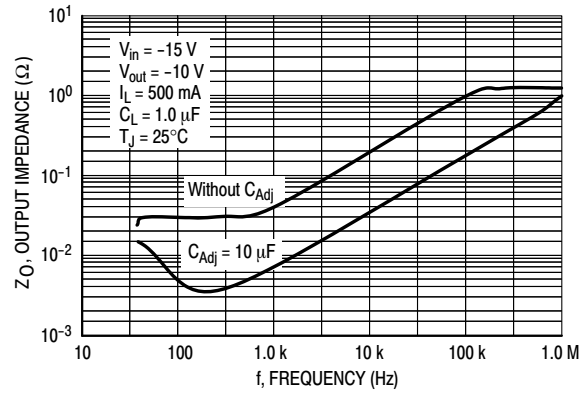
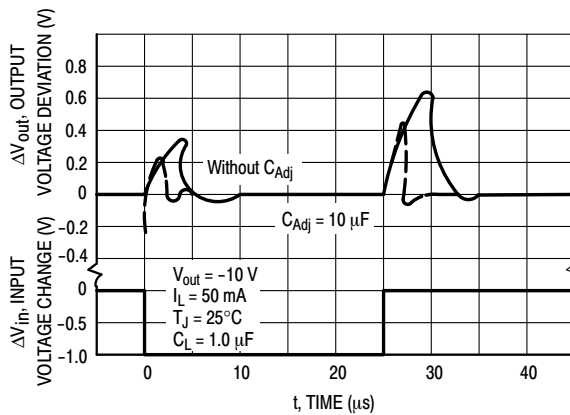
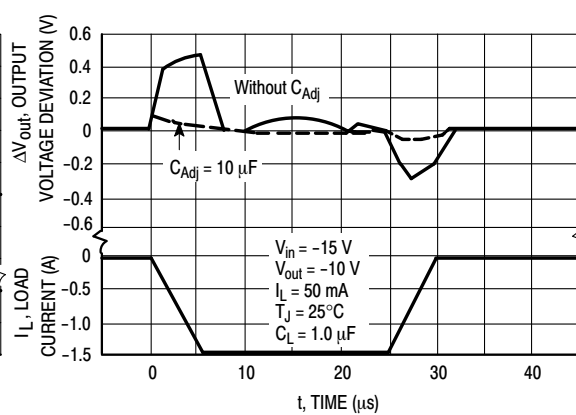
**Figure 11. Ripple Rejection versus Output Voltage**

**Figure 12. Ripple Rejection versus Output Current**

**Figure 13. Ripple Rejection versus Frequency**

**Figure 14. Output Impedance**

**Figure 15. Line Transient Response**

**Figure 16. Load Transient Response**

**APPLICATIONS INFORMATION**
**Basic Circuit Operation**

The HT337 is a 3-terminal floating regulator. In operation, the HT337 develops and maintains a nominal  $-1.25\text{ V}$  reference ( $V_{\text{ref}}$ ) between its output and adjustment terminals. This reference voltage is converted to a programming current ( $I_{\text{PROG}}$ ) by  $R_1$  (see Figure 17), and this constant current flows through  $R_2$  from ground.

The regulated output voltage is given by:

$$V_{\text{out}} = V_{\text{ref}} \left( 1 + \frac{R_2}{R_1} \right) + I_{\text{Adj}} R_2$$

Since the current into the adjustment terminal ( $I_{\text{Adj}}$ ) represents an error term in the equation, the HT337 was designed to control  $I_{\text{Adj}}$  to less than  $100\ \mu\text{A}$  and keep it constant. To do this, all quiescent operating current is returned to the output terminal. This imposes the requirement for a minimum load current. If the load current is less than this minimum, the output voltage will rise.

Since the HT337 is a floating regulator, it is only the voltage differential across the circuit which is important to performance, and operation at high voltages with respect to ground is possible.

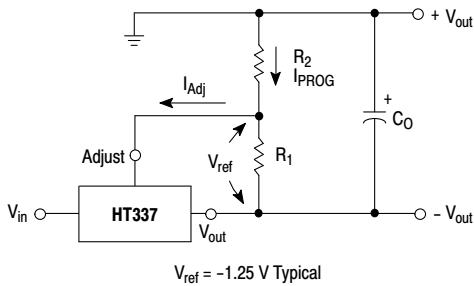

**Figure 17. Basic Circuit Configuration**

**Load Regulation**

The HT337 is capable of providing extremely good load regulation, but a few precautions are needed to obtain maximum performance. For best performance, the programming resistor ( $R_1$ ) should be connected as close to the regulator as possible to minimize line drops which effectively appear in series with the reference, thereby degrading regulation. The ground end of  $R_2$  can be returned near the load ground to provide remote ground sensing and improve load regulation.

**External Capacitors**

A  $1.0\ \mu\text{F}$  tantalum input bypass capacitor ( $C_{\text{in}}$ ) is recommended to reduce the sensitivity to input line impedance.

The adjustment terminal may be bypassed to ground to improve ripple rejection. This capacitor ( $C_{\text{Adj}}$ ) prevents ripple from being amplified as the output voltage is increased. A  $10\ \mu\text{F}$  capacitor should improve ripple rejection about  $15\ \text{dB}$  at  $120\ \text{Hz}$  in a  $10\ \text{V}$  application.

An output capacitance ( $C_O$ ) in the form of a  $1.0\ \mu\text{F}$  tantalum or  $10\ \mu\text{F}$  aluminum electrolytic capacitor is required for stability. Using the classical tantalum or aluminum electrolytic capacitor types with non-reduced ESR (Equivalent Series Resistance) value is necessary. Low-ESR or similar capacitor types with reduced ESR value and ceramic capacitors can cause instability or continuous oscillations in the application.

**Protection Diodes**

When external capacitors are used with any IC regulator it is sometimes necessary to add protection diodes to prevent the capacitors from discharging through low current points into the regulator.

Figure 18 shows the HT337 with the recommended protection diodes for output voltages in excess of  $-25\ \text{V}$  or high capacitance values ( $C_O > 25\ \mu\text{F}$ ,  $C_{\text{Adj}} > 10\ \mu\text{F}$ ). Diode  $D_1$  prevents  $C_O$  from discharging thru the IC during an input short circuit. Diode  $D_2$  protects against capacitor  $C_{\text{Adj}}$  discharging through the IC during an output short circuit. The combination of diodes  $D_1$  and  $D_2$  prevents  $C_{\text{Adj}}$  from the discharging through the IC during an input short circuit.

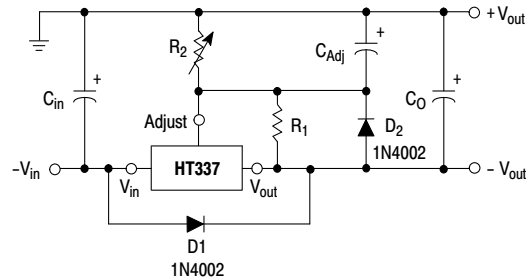

**Figure 18. Voltage Regulator with Protection Diodes**

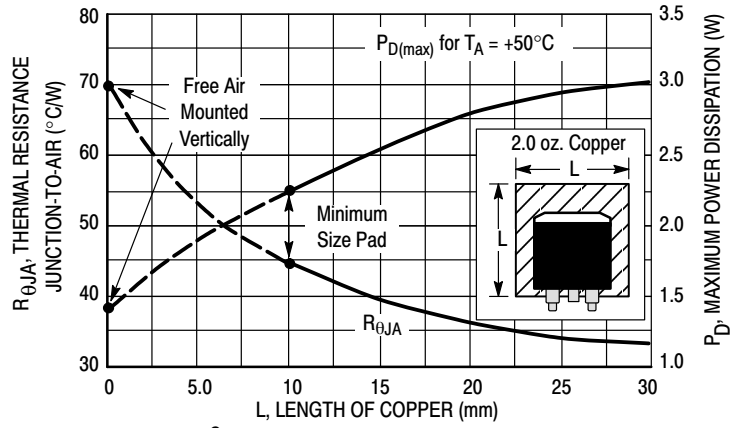
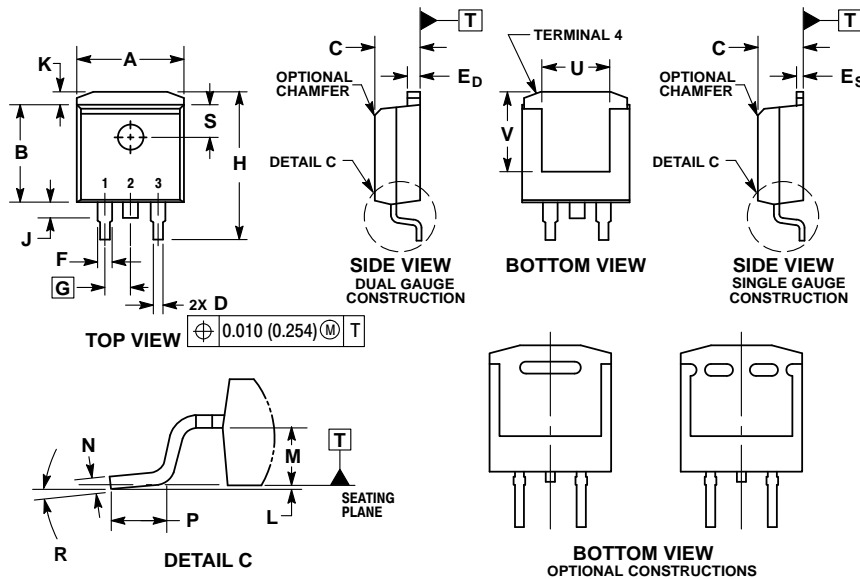

Figure 19. D<sup>2</sup>PAK Thermal Resistance and Maximum Power Dissipation versus P.C.B. Copper Length



TO263



- NOTES:
1. DIMENSIONING AND TOLERANCING PER ANSI Y14.5M, 1982.
  2. CONTROLLING DIMENSION: INCHES.
  3. TAB CONTOUR OPTIONAL WITHIN DIMENSIONS A AND K.
  4. DIMENSIONS U AND V ESTABLISH A MINIMUM MOUNTING SURFACE FOR TERMINAL 4.
  5. DIMENSIONS A AND B DO NOT INCLUDE MOLD FLASH OR GATE PROTRUSIONS. MOLD FLASH AND GATE PROTRUSIONS NOT TO EXCEED 0.025 (0.635) MAXIMUM.
  6. SINGLE GAUGE DESIGN WILL BE SHIPPED AFTER FPCN EXPIRATION IN OCTOBER 2011.

DIM	INCHES		MILLIMETERS	
	MIN	MAX	MIN	MAX
A	0.386	0.403	9.804	10.236
B	0.356	0.368	9.042	9.347
C	0.170	0.180	4.318	4.572
D	0.026	0.036	0.660	0.914
E <sub>D</sub>	0.045	0.055	1.143	1.397
E <sub>S</sub>	0.018	0.026	0.457	0.660
F	0.051	REF	1.295	REF
G	0.100	BSC	2.540	BSC
H	0.539	0.579	13.691	14.707
J	0.125	MAX	3.175	MAX
K	0.050	REF	1.270	REF
L	0.000	0.010	0.000	0.254
M	0.088	0.102	2.235	2.591
N	0.018	0.026	0.457	0.660
P	0.058	0.078	1.473	1.981
R	5°	REF	5°	REF
S	0.116	REF	2.946	REF
U	0.200	MIN	5.080	MIN
V	0.250	MIN	6.350	MIN

SOLDERING FOOTPRINT\*

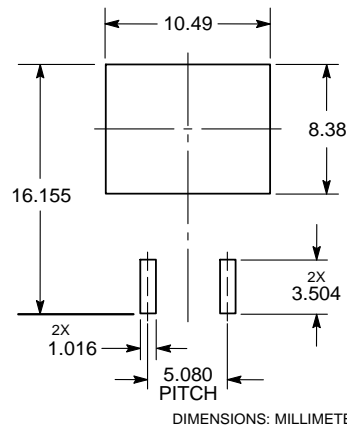

\*For additional information on our Pb-Free strategy and soldering details, please download the ON Semiconductor Soldering and Mounting Techniques Reference Manual, SOLDERRM/D.

**TO220**

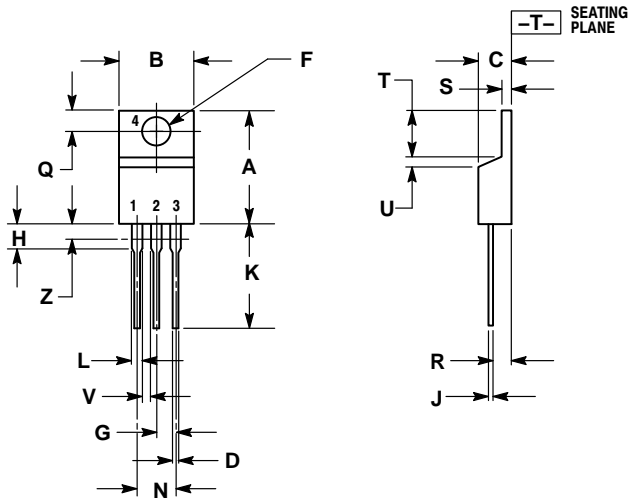

- NOTES:
1. DIMENSIONING AND TOLERANCING PER ANSI Y14.5M, 1982.
  2. CONTROLLING DIMENSION: INCHES.
  3. DIMENSION Z DEFINES A ZONE WHERE ALL BODY AND LEAD IRREGULARITIES ARE ALLOWED.
  4. PRODUCT SHIPPED PRIOR TO 2008 HAD DIMENSIONS S = 0.045 - 0.055 INCHES (1.143 - 1.397 MM)

DIM	INCHES		MILLIMETERS	
	MIN	MAX	MIN	MAX
A	0.570	0.620	14.48	15.75
B	0.380	0.405	9.66	10.28
C	0.160	0.190	4.07	4.82
D	0.025	0.035	0.64	0.88
F	0.142	0.147	3.61	3.73
G	0.095	0.105	2.42	2.66
H	0.110	0.155	2.80	3.93
J	0.018	0.025	0.46	0.64
K	0.500	0.562	12.70	14.27
L	0.045	0.060	1.15	1.52
N	0.190	0.210	4.83	5.33
Q	0.100	0.120	2.54	3.04
R	0.080	0.110	2.04	2.79
S	0.020	0.024	0.508	0.61
T	0.235	0.255	5.97	6.47
U	0.000	0.050	0.00	1.27
V	0.045	---	1.15	---
Z	---	0.080	---	2.04

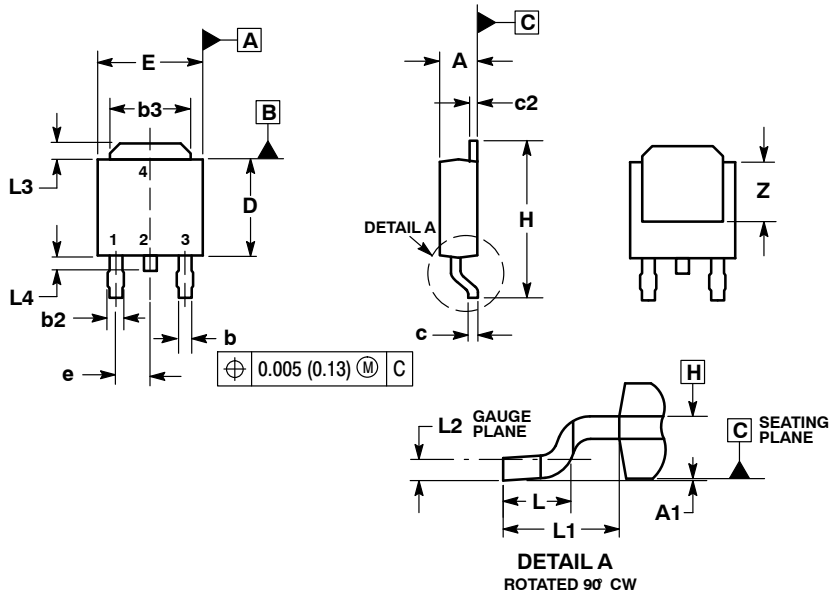
**TO252**

**NOTES:**

1. DIMENSIONING AND TOLERANCING PER ASME Y14.5M, 1994.
2. CONTROLLING DIMENSION: INCHES.
3. THERMAL PAD CONTOUR OPTIONAL WITHIN DIMENSIONS b3, L3 and Z.
4. DIMENSIONS D AND E DO NOT INCLUDE MOLD FLASH, PROTRUSIONS, OR BURRS. MOLD FLASH, PROTRUSIONS, OR GATE BURRS SHALL NOT EXCEED 0.006 INCHES PER SIDE.
5. DIMENSIONS D AND E ARE DETERMINED AT THE OUTERMOST EXTREMES OF THE PLASTIC BODY.
6. DATUMS A AND B ARE DETERMINED AT DATUM PLANE H.

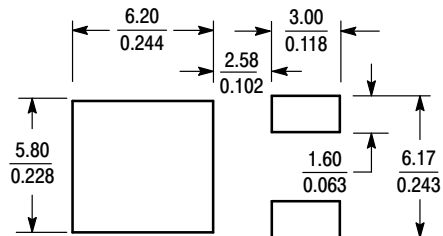
DIM	INCHES		MILLIMETERS	
	MIN	MAX	MIN	MAX
A	0.086	0.094	2.18	2.38
A1	0.000	0.005	0.00	0.13
b	0.025	0.035	0.63	0.89
b2	0.030	0.045	0.76	1.14
b3	0.180	0.215	4.57	5.46
c	0.018	0.024	0.46	0.61
c2	0.018	0.024	0.46	0.61
D	0.235	0.245	5.97	6.22
E	0.250	0.265	6.35	6.73
e	0.090 BSC		2.29 BSC	
H	0.370	0.410	9.40	10.41
L	0.055	0.070	1.40	1.78
L1	0.108 REF		2.74 REF	
L2	0.020 BSC		0.51 BSC	
L3	0.035	0.050	0.89	1.27
L4	---	0.040	---	1.01
Z	0.155	---	3.93	---

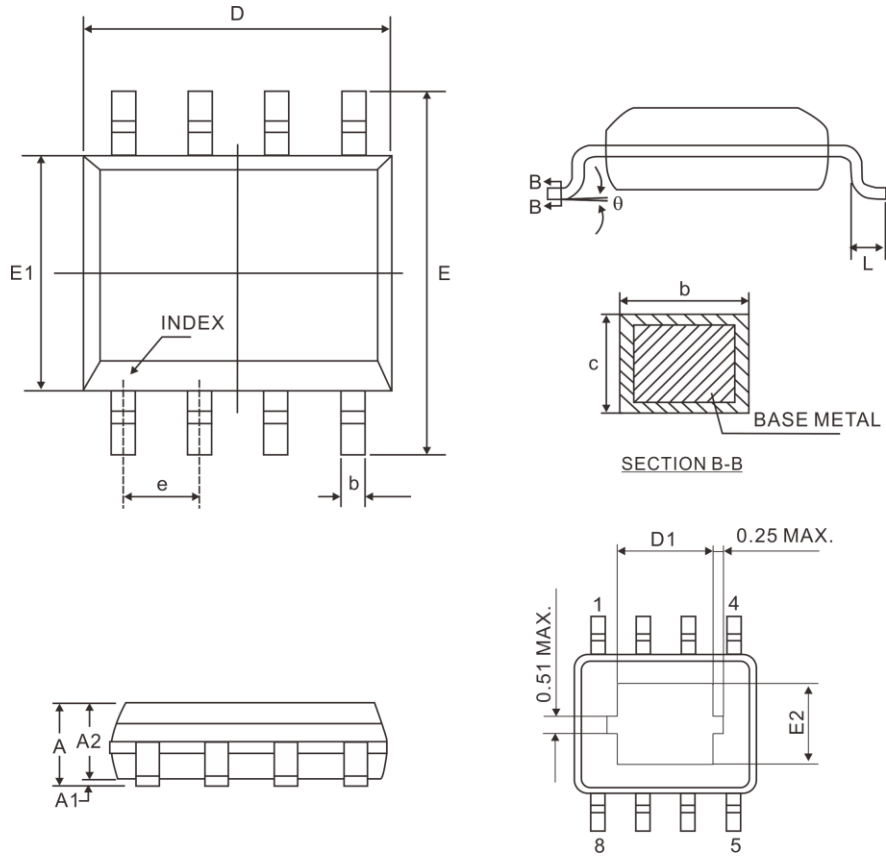
**SOLDERING FOOTPRINT\***

**ESOP8**

Symbol	Dimensions(mm)		
	Min.	Nom.	Max.
A	-	-	1.70
A1	0.00	-	0.15
A2	1.25	-	-
b	0.31	-	0.51
c	0.10	-	0.25
e	1.27 BSC		
D	4.90 BSC		
D1	2.81	-	3.30
E	6.00 BSC		
E1	3.90 BSC		
E2	2.05	-	2.41
L	0.40	0.60	1.27
$\theta$	0°	-	8°

SOT-223

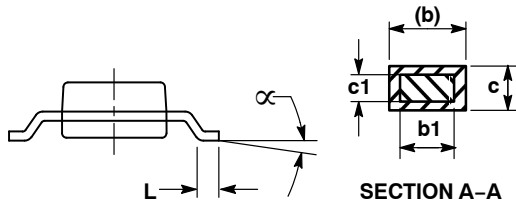
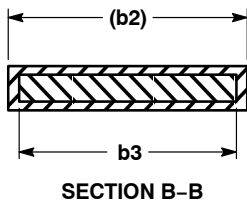
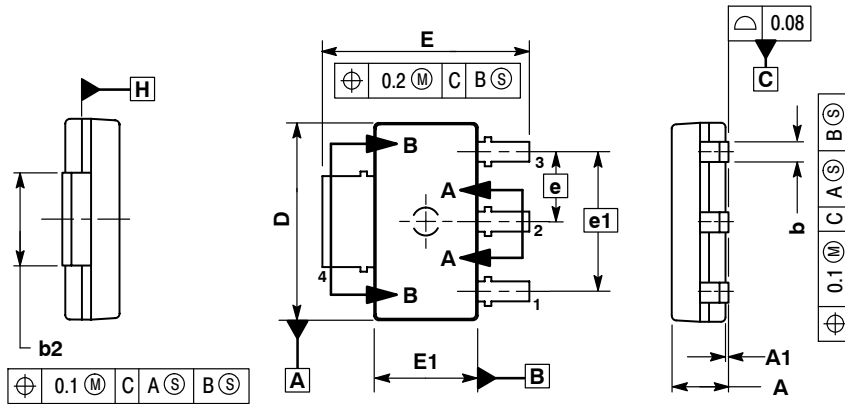

**NOTES:**

1. DIMENSIONS ARE IN MILLIMETERS.
2. INTERPRET DIMENSIONS AND TOLERANCES PER ASME Y14.5M, 1994.
3. DIMENSION E1 DOES NOT INCLUDE INTERLEAD FLASH OR PROTRUSION. INTERLEAD FLASH OR PROTRUSION SHALL NOT EXCEED 0.23 PER SIDE.
4. DIMENSIONS b AND b2 DO NOT INCLUDE DAMBAR PROTRUSION. ALLOWABLE DAMBAR PROTRUSION SHALL BE 0.08 TOTAL IN EXCESS OF THE b AND b2 DIMENSIONS AT MAXIMUM MATERIAL CONDITION.
5. TERMINAL NUMBERS ARE SHOWN FOR REFERENCE ONLY.
6. DIMENSIONS D AND E1 ARE TO BE DETERMINED AT DATUM PLANE H.

MILLIMETERS		
DIM	MIN	MAX
A	---	1.80
A1	0.02	0.11
b	0.60	0.88
b1	0.60	0.80
b2	2.90	3.10
b3	2.90	3.05
c	0.24	0.35
c1	0.24	0.30
D	6.30	6.70
E	6.70	7.30
E1	3.30	3.70
e	2.30	
e1	4.60	
L	0.25	---
α	0°	10°

**SOLDERING FOOTPRINT\***

