

General Description

The HT3402S is a constant current, constant voltage power supply converter, which utilizes a voltage mode, a current mode circuit, and pulse width modulation (PWM) switching regulator control circuit

An external sense resistor will set the charge current. An internal resistor divider and precision reference set the final float voltage to 5.1V with $\pm 3\%$ accuracy. With a 150 KHz switching frequency, HT3402S can provide a simple solution against EMI. High efficiency up to 90% can also diminish heat significantly on all related components.

The HT3402S also possesses over-voltage protect, over-thermal protect, and short-circuit protect function. At the beginning of the charge, the over-current circuit will limit the charge current not too high.

The HT3402S is available in a 8-pin SOP8 package

Features

- ✧ Wide Input Supply Range: 10V to 40V
- ✧ $\pm 3\%$ Charge Voltage Accuracy;
- ✧ High Efficiency Current Mode PWM Control with 150KHz Switching Frequency
- ✧ Constant Switching Frequency for Minimum Noise
- ✧ Cable compensation function
- ✧ Automatic Battery Recharge
- ✧ Automatic Shutdown When Input Supply Removed
- ✧ Available in a 8-pin SOP8 package

Applications

- ✧ SMPS
- ✧ Charger
- ✧ Portable Computers
- ✧ Handheld Instruments

Typical Application Circuitry

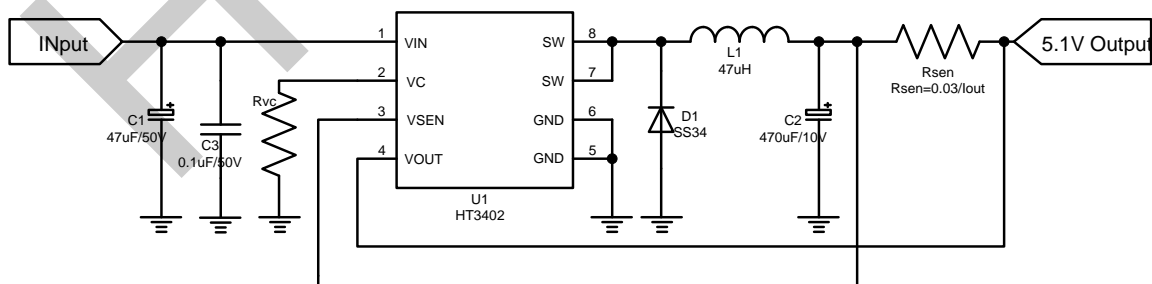

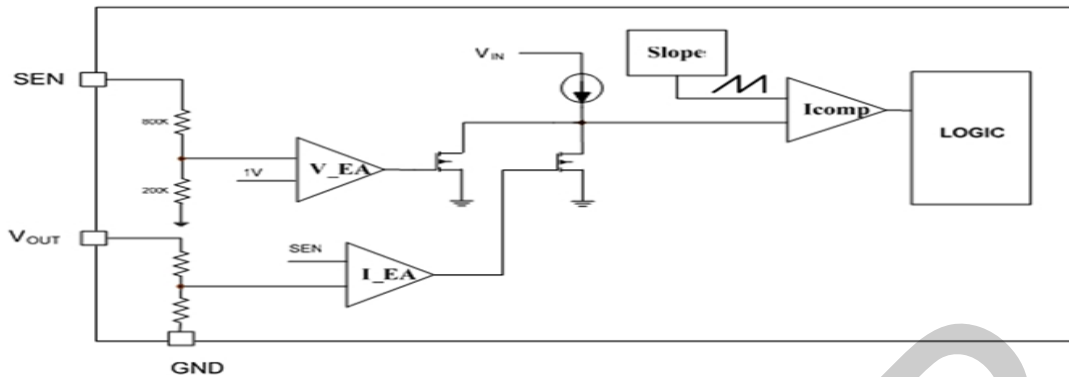

Cable Resistance Compensation

- ✧ The longer cable of car charger reduces output voltage. Add voltage compensation function will increase the output voltage and make the output of cable is remained to be the design value. An external resistor will be connected to the VCABLE pin to match the immanent resistor of cable. In the cable compensation circuit, the voltage of the VCABLE pin will be raised as the load current increase; the reference voltage of voltage loop will be raised to an appropriate value, and finished the compensation function. If there is no load, no compensation resistors or output current is zero, the output voltage will not rise. Set VCABLE pin in floating state to turn off this function off. Selection of external compensation resistor is based on the equivalent resistance of cable. Compensating voltage can be determined by equation:

$$V_{cable} = \frac{2000K}{R_{cable}} \times I_{out} \times R_{sen}$$

Over Voltage protection

When the output voltage of HT3402S is 10% higher than the targeting voltage, the PMOS will be turned off.

Thermal Shutdown (OTP)

An internal thermal loop can monitor internal junction temperature rigorously. If the temperature surpasses a preset value of approximately 120°C, HT3402S stops output

Short- circuit protection

- ✧ At the beginning of enable HT3402S, system charges the load for about 100ms. If the short circuit protection module detect the output voltage is fallen down to 1.5V, it sends a single to Logic Circuit to turn off IC. When short circuit happens, a current of about 2 mA will charge the load. If the short circuit state is aligned, charge voltage will raise above 1.5V and being detected, system is resumed to normal

Over Current Protection

- ✧ HT3402S has an internal over-current protection circuit that limits the inrush current during start-up. At the beginning of the start-up, the over-current protection circuit will detect the current, if it's too high to exceed the safe value, the PMOS will be turn-off. But when output is rise to the design voltage, the protect function will not active anymore. The I-EA will replace the function to limiting the current.

Application Information

- ✧ The basic application circuit of HT3402S is shown in Figure 1. External components selection is depend on load requirement, and begin with the selection of inductor followed by capacitor

Inductor Selection

- ✧ For most application, HT3402S operates well with inductors of 100uH, the inductor is selected to limit the ripple current with some predetermined value, typically 20~40% of the full load current at the maximum input voltage. The equation of inductance is as below:

$$\Delta I_L = K \times \frac{1 - V_{OUT} / V_{IN}}{L \times f} \quad (K=0.2\sim0.4)$$

$$L = \frac{V_{OUT}}{f \times \Delta I_L} \left(1 - \frac{V_{OUT}}{V_{IN}} \right)$$

- ✧ The DC current rating of the inductor should be at least equal to the maximum load current plus half of the ripple current to prevent core saturation. For example $\Delta I_L = 1000\text{mA} \times 40\% = 400\text{mA}$, thus, a 1400mA rated inductor should be enough for most application(1000mA+400mA). For better efficiency, choose a low DCR inductor.

Input Capacitor Selection

- ✧ The input capacitor reduces surge current drawn from input and switching noise from the device. Input capacitor impedance at the switching frequency shall be less than input source impedance to prevent high frequency switching current passing to the input. A low ESR input capacitor sized for max. RMS current must be used. A 100uF ceramic capacitor for most application is sufficient and recommended.

Output Capacitor Selection

- ✧ The output capacitor is required to keep the output voltage ripple small and to stabilize regulation loop . It must have low impedance at the switching frequency. Ceramic capacitors with X5R or X7R dielectrics are recommended due to their low ESR and high ripple current. The output ripple V_{OUT} is determined by below equation:

$$\Delta V_{OUT} = \Delta I_L \left(ESR + \frac{1}{8 f C_{OUT}} \right)$$

Load Current Limit Programming

- ✧ The constant current I_{CHG} is controlled by a sensing resistor connected between Inductor and Output. The Voltage- drop of the sensing resistor (R_{SEN}) is internally regulated to 30mV, which sets the current flowing through R_{SEN}. For better accuracy, a 2% or more accurate Resistor is recommended. Table 1 shows several typical 1% R_{SEN} values:

Table 1

I _{CHG} (mA)	R _{SEN} (mΩ)
2000	15
1000	30

- ✧ For other constant current values, R_{SEN} can be determined by the following equation::

$$R_{sen} = \frac{0.03}{I_{out}}$$

Pin Configuration

	Name	Pin #	Function Description
	V _{IN}	1	Power Supply Input
1 □	V _{CABLE}	2	Connect a suitable resistor to the compensation voltage and improve the output power which the cable wasted.
8 □			Set this pin sets float to turn off cable compensation function.
2 □	SEN	3	Output Voltage feedback
3 □	V _{OUT}	4	Output power supply to back- end devices. <small>Note1</small>
4 □	GND	5	Ground of IC
	GND	6	Ground of IC
	SW	7	SW Output.
	SW	8	SW Output.

Note1: V_{OUT} can be programmed to compensate the drop- out voltage from longer cable.

Absolute Maximum Ratings

PARAMETER	SYMBOL	MIN	MAX	UNITS
Input Supply Voltage	V_{IN}	10	40	V
Operating Temperature Range	T_{OPR}	-20	85	°C
Storage Temperature Range	T_{STG}	-20	150	°C
Junction Temperature	θ_{JA}	---	125	°C
Lead Temperature (Soldering, 10s)	T_{LTG}	---	260	°C

Electrical Characteristics

(Circuit of Figure 1, $T_A = 25^\circ\text{C}$, $V_{IN}=12\text{V}$, $V_{OUT}=5.1\text{V}$, unless otherwise noted.)

SYMBOL	PARAMETER	CONDITIONS	MIN	TYP	MAX	UNITS
V_{IN}	Power Supply Input Voltage	-	10	-	40	V
V_{OUT}	Output Voltage	-	4.95	5.1	5.25	V
I_{CHG}	Constant Current Mode Charge Current	$R_{SEN}=15\text{m}\Omega$	2.0	2.40	2.8	A
		$R_{SEN}=30\text{m}\Omega$	1.0	1.20	1.40	A
I_Q	Quiescent current	No load	-	-	220	μA
V_{RIPPLE}	Output Ripple Voltage	$I_{LOAD}=1\text{A}$	50	-	80	mV
T_{ON}	The time of output voltage up to V_{OUT}	$V_{OUT}=5.1\text{V}$	6	10	12	mS
F	Frequency	$I_{LOAD}=0.5\text{A}$	120	150	180	KHz
V_{SHORT}	Short Circuit threshold	-	1.0	1.5	1.8	V
	Recover Short Circuit threshold	-	1.5	1.8	2.0	V
I_{SHORT}	Short Circuit Current	When short- circuit appears	1.5	2	3	mA
V_{CABLE}	Cable compensation voltage	$V_{CABLE} = \frac{2000k \times I_{load} \times R_{sen}}{R_{CABLE}}$	-	-	1000	mV
T_{PRO}	Over temperature threshold	-	130	140	150	°C
T_{RE}	Release threshold from over temperature	-	110	120	130	°C

Typical Operating Characteristics

(Circuit of Figure 1, $T_A = 25^\circ\text{C}$, $V_{IN}=12\text{V}$, $V_{OUT}=5.1\text{V}$, unless other specified.)

Efficiency vs Load Current

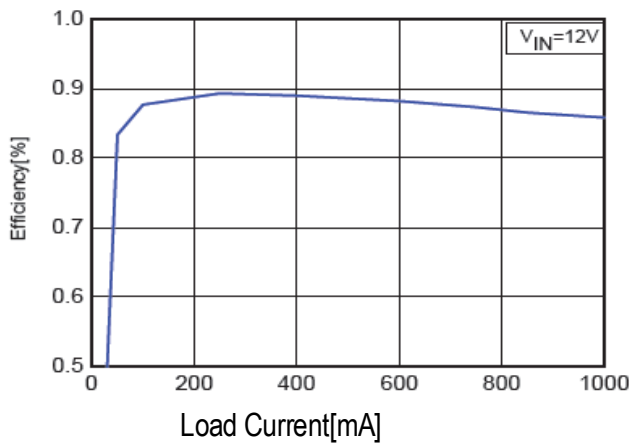

Efficiency vs Load Current

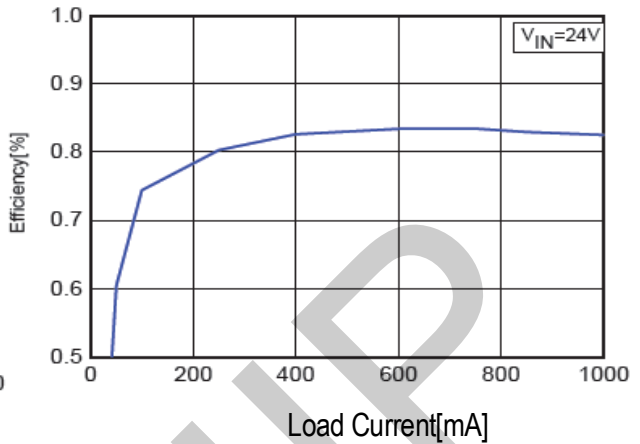

Output Ripple Voltage vs Input Voltage

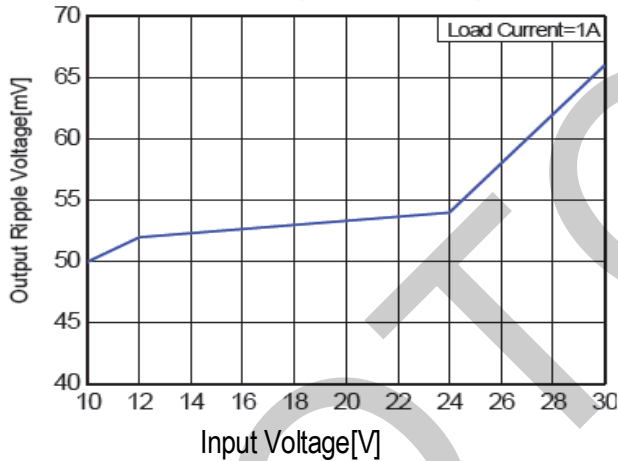

Output Ripple Voltage vs Input Voltage

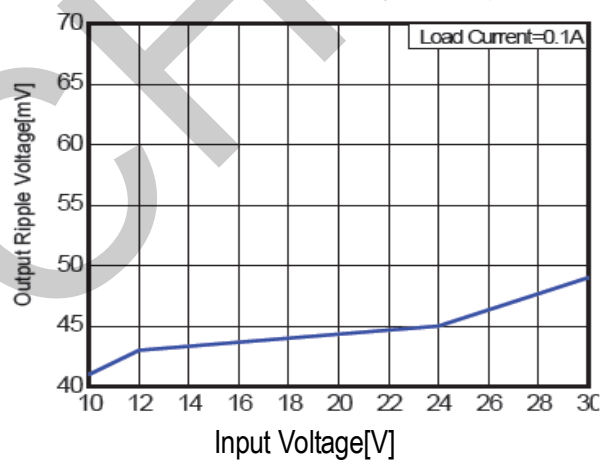

Output Ripple Voltage vs Input Voltage

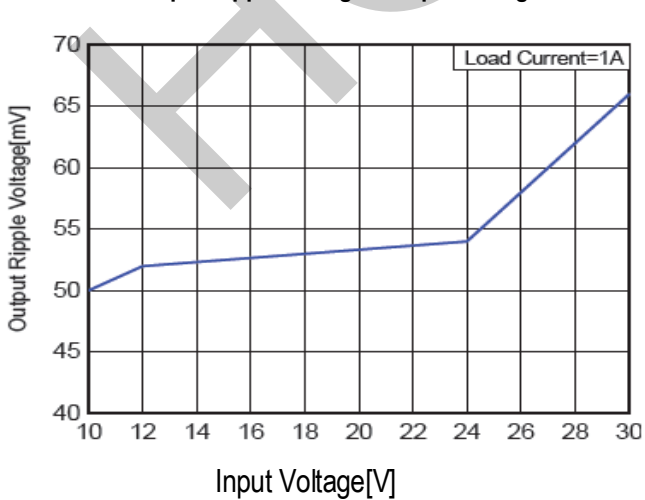

Output Ripple Voltage vs Input Voltage

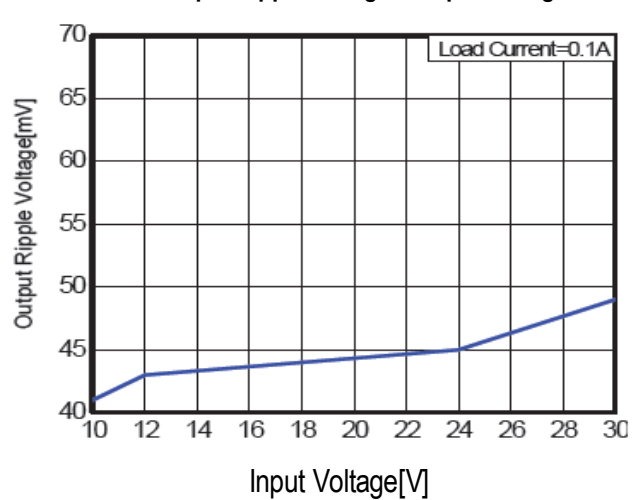

Cable compensation vs Load Current

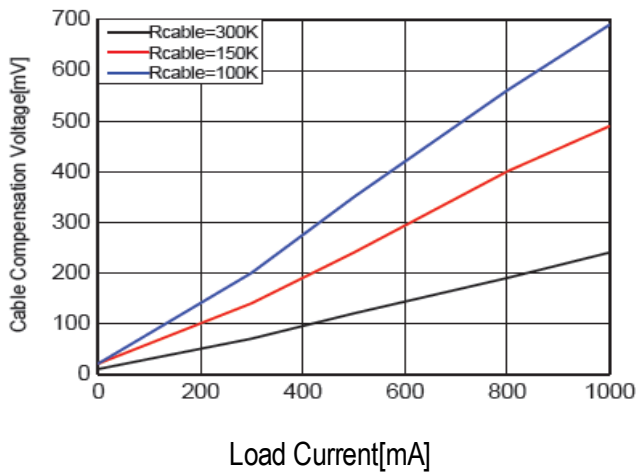

Quiescent current vs Input Voltage

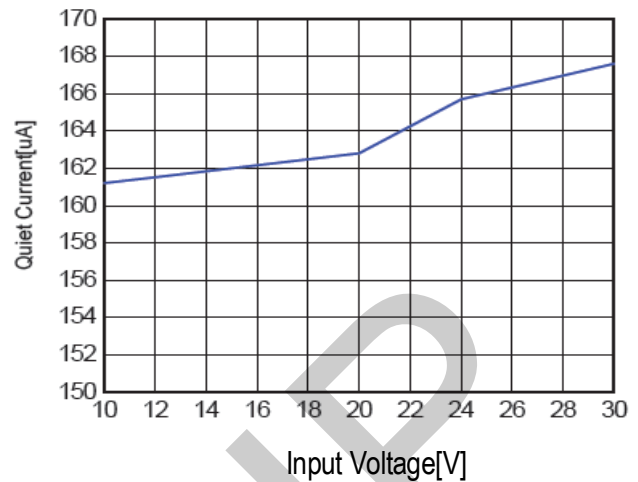

Layout Notice

- ◆ C3 is adopted for filtering high Freq. noise, should be set as close as it can be to Pin #1 of U1, <1mm is recommended; C1 is however with consideration of its size to be installed a bit distant. Input power flows thru. C1 and then C3 to U1.
- ◆ D1 generates higher heat and composes a loop with L1 and C2, it is suggested to arrange these three components as close as possible, and keep distant from U1 with at least 10mm to avoid heat to trigger OTP function on U1
- ◆ Sensing Resistor connects to Pin # 3 and # 4 of U1, and routing must compose Kelvin Method between anode of C1 and USB output so that sample being sensed is directly from both sides of Rsen, and avoid from other resistance coming from other PCB route.

Current must flow from L1 to anode of C2, and connect to one node of Rsen, then flown out from the other node to USB directly. If current flows inappropriately, sampling/ sensing resistance might increase and result in lower output current.
- ◆ Pin # 1/ 5/ 6/ 7/ 8 of U1 on PCB is recommended to manipulated with larger area of bare copper and a bit thicker tin paste spread on this area can also help for better heat dissipation. This action can also apply to both soldering pads of D1.
- ◆ USB port on PCB can be managed on D+/ D- anodes with designated resistors if necessary to fit in with Apple handsets, while in most occasions, put them short- CKT will also do.

◆ Reference PCB Layout is shown as followed--

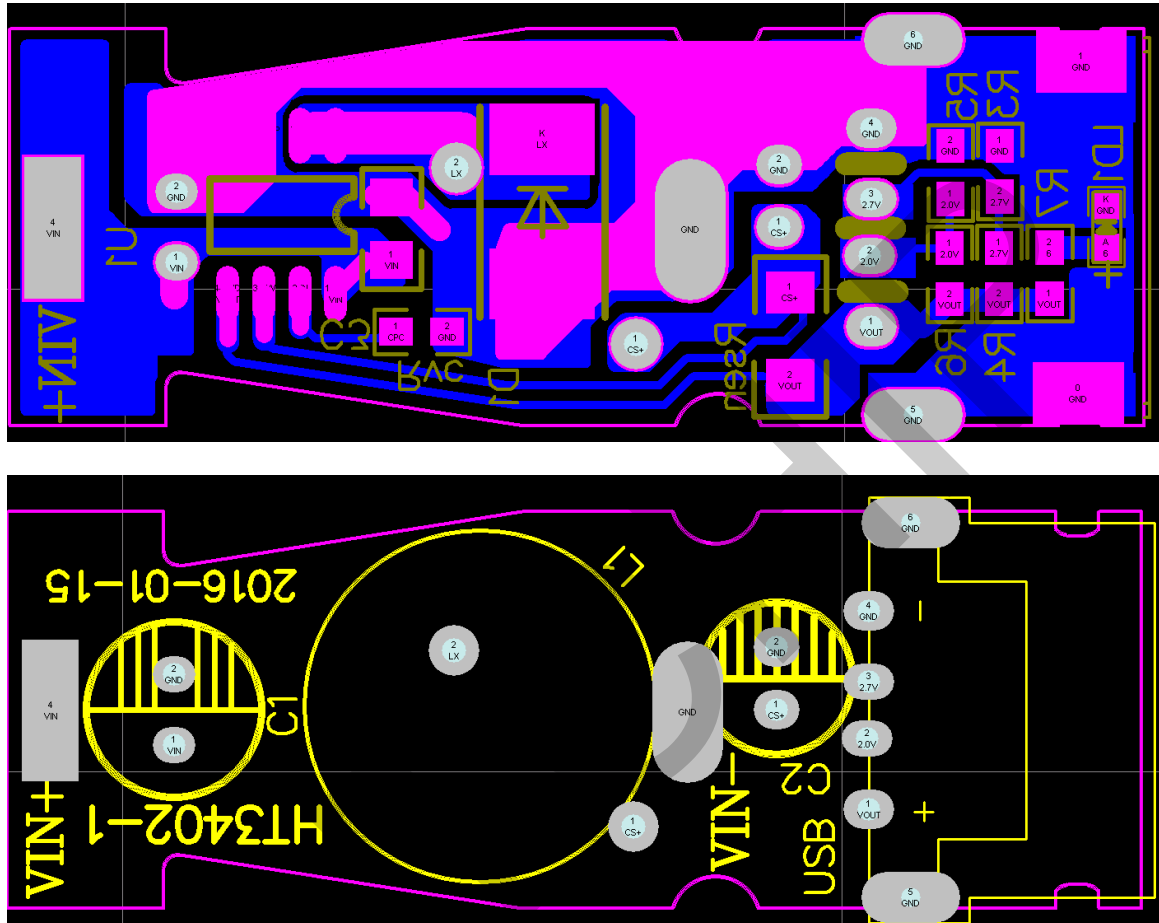

Package Outline Dimension

SOP- 8 Package

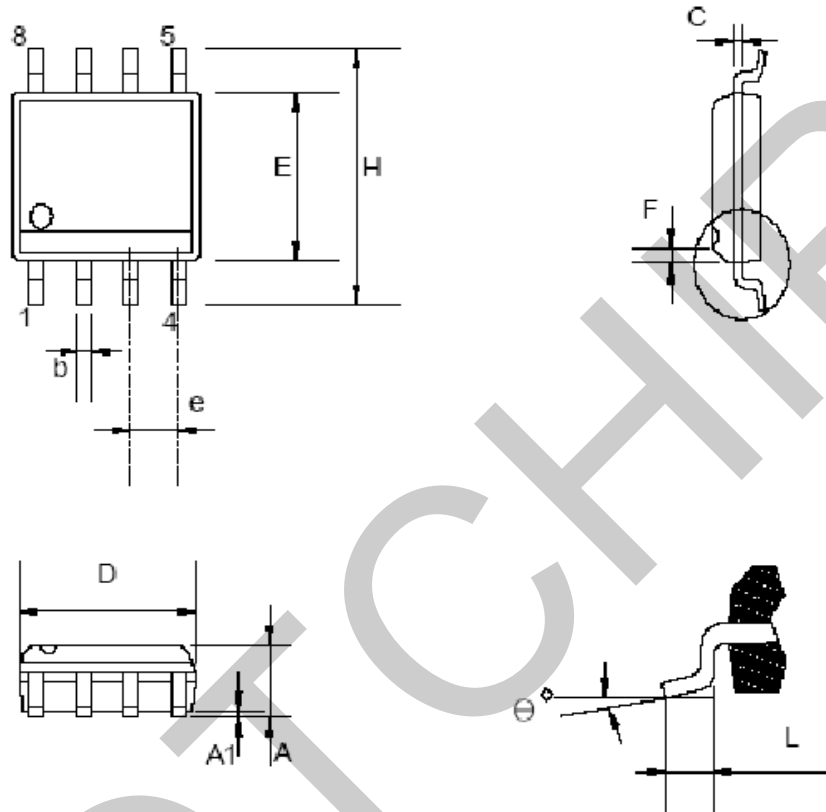

Symbo	Dimensions In Millimeters			Dimensions In Inches		
	Min	Typ.	Max	Min	Typ.	Max
A	1.346		1.752	0.053		0.069
A1	0.101		0.254	0.004		0.010
b		0.406			0.016	
c		0.203			0.008	
D	4.648		4.978	0.183		0.196
E	3.810		3 87	0.150		0.157
e	1.016	1.270	1.524	0.040	0.050	0.060
F		0.381*45°			0.015*45°	
H	5.791		6.197	0.228		0.244
L	0.406		1.270	0.016		0.050
θ°	0°		8°	0°		8°

Packing And Ordering Info.

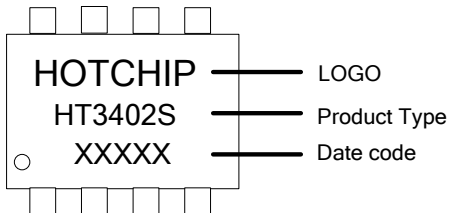

Package	Top Marking	Device Name
SOP-8	HT3402S	HT3402S- BA

IMPORTANT NOTICE

- ✧ HOTCHIP reserves the right to alter its products without prior notification. For the most up-to-date information, please visit our web site at <http://www.hotchip.com.cn>.
- ✧ HOTCHIP assumes no liability for the issues about the industrial standard, licenses and the right of the third party caused by the electric circuit and chart. The schematic is just for typical application, is not for the specialized mass production application.
- ✧ The export authorization from government is needed when the product or its derivative product do not agree with the Wassenaar Arrangement or other international agreement.
- ✧ Any copy of these information without our permission to print for other uses is forbidden.
- ✧ HOTCHIP's products are not authorized for use as critical components in life support devices or systems, such as motion machine, medical machine, security system, gas equipment, airplane or any other conveyance.
- ✧ HOTCHIP cannot avoid fault or losing efficacy, though we will do the best to improve the quality and reliability. The customers use the products should go through the security design, such as the redundant design, fire protection design, failure protection about the secondary disasters, fire or other related damage.
- ✧ HOTCHIP will continuously provide better products for the customers by all our heart.