

过电压保护IC

Over Voltage Protection IC

■ FEATURES

- Input Voltage Range: 3V to 36V
 - Output Power on Time: 10ms (Typ.)
 - OVP Threshold
Fixed 5.85V (Typ.) or Externally adjustable OVP voltage
 - 60ns Fast Transient response
 - RDS(ON) Internal Switches: 125mΩ
 - Under-Voltage, and Thermal Shutdown Protection
 - Packages: Pb-free Packages, SOT23-6
- 输入电压范围: 3V~36V
 - 开启延时时间: 10ms (Typ.)
 - OVP电压: 固定5.85V(Typ.), 或外部可调
 - 60ns快速OVP响应时间
 - 内置MOS RDS(ON) 125mΩ
 - 欠压保护和过温关断保护
 - SOT23-6封装

■ APPLICATIONS

- GPS
 - TWS, Speakers
 - Smart Phone
 - Digital cameras
 - Tablet, MID, PAD
 - Peripherals
 - Power bank
- GPS
 - TWS, 音箱
 - 智能手机
 - 数字摄像机
 - 平板, MID, PAD
 - 外围设备
 - 充电宝

■ DESCRIPTION

The HT4066 over-voltage protection device features an ultra-low 125mΩ (TYP) on-resistance high current integrated MOSFET which actively protect low-voltage systems from voltage supply faults up to +36VDC.

The device will switch off internal MOSFET to disconnect VIN to VOUT to protect load when input voltage over the threshold.

When the OVLO input is connected to GND, the HT4066 automatically choose the internal fixed OVLO threshold, preset to be 5.85V typical. The over-voltage protection threshold can be adjusted with an optional external resistor-divider to a voltage between 4V and 10V.

In case the device temperature exceeds the maximum junction temperature, the device switches off.

The HT4066 are available in Green SOT23-6 package, and operate over an ambient temperature range of -40°C to +85°C.

HT4066是一颗过压保护IC，其内置125mΩ (TYP)大电流MOS，其可对低电压工作的系统进行电压保护，最高+36VDC。

当VIN电压超过OVP值时，HT4066将关闭MOS以关断VIN到VOUT的路径，从而保护负载。

当OVLO接地时，HT4066自动设置为固定的5.85V过压保护值。OVLO外接分压电阻时，可设置4~10V的过压保护值。

当HT4066超过最大结温时，器件关闭。

该产品提供SOT23-6封装，支持-40°C到+85°C的环境温度。

TYPICAL APPLICATION

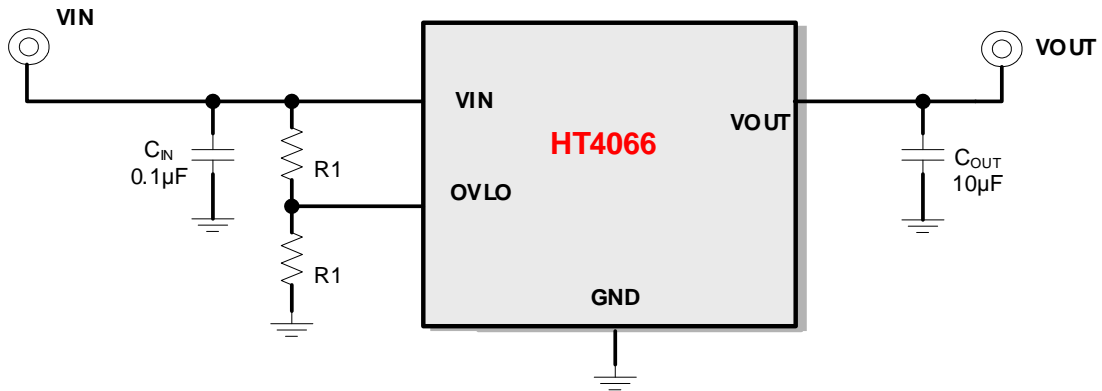

ORDERING INFORMATION

Part Number	Package Type	Marking	Operating Temperature Range	Shipping Package / MOQ
HT4066A2STNR	SOT23-6 (STN)	40LYAA	-40℃~85℃	Tape and Reel (R) / 3000pcs

Part Number

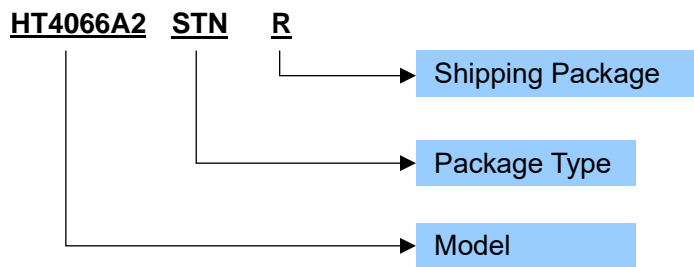

Marking

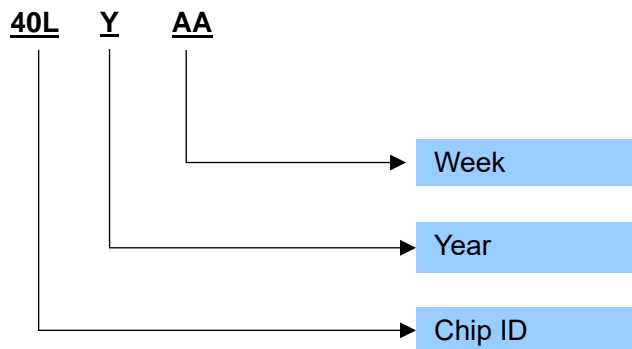

:

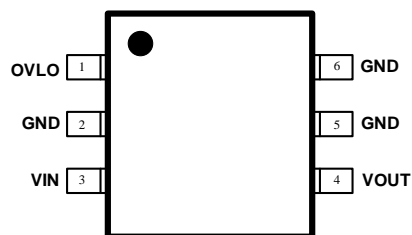
■ TERMINAL CONFIGURATION

Top View
■ TERMINAL FUNCTION

Terminal No.	Name	Description
1	OVLO	External OVLO Adjustment. Connect OVLO to GND when using the internal threshold. Connect a resistor divider to OVLO to set a different OVLO threshold.
2, 5, 6	GND	Ground.
3	VIN	Input Voltage. Bypass VIN with 0.1uF capacitor as close as possible to the device.
4	VOUT	Output voltage. Bypass VOUT with 10uF capacitor as close as possible to the device.

■ SPECIFICATIONS¹
● Absolute Maximum Ratings²

PARAMETER	Symbol	MIN	TYP	MAX	UNIT
Input Voltage Range	V _{IN}	-0.3		36	V
Output Voltage Range	V _{OUT}	-0.3		V _{IN} +0.3	V
OVLO pin	OVLO	-0.3		7	V
Continuous Current	I _{IN}			3	A
Moisture Sensitivity Level (MSL)			MSL3		
Ambient Operating Temperature	T _A	-40		85	°C
Junction Temperature	T _J	-40		150	°C
Storage Temperature	T _{STG}	-55		150	°C

● Recommended Operating Conditions

PARAMETER	Symbol	CONDITION	MIN	TYP	MAX	UNIT
Input Voltage Range	V _{IN}		2.7		36	V
Output Capacitance Range	C _{OUT}		10		100	uF
Ambient Operating Temperature	T _a		-40	25	85	°C

● ELECTRICAL CHARACTERISTICS

(V_{IN} = 5V, I_{IN} ≤ 3A, T_A = -40°C to +85°C, typical values are at T_A = +25°C, unless otherwise noted.)

PARAMETER	Symbol	CONDITION	MIN	TYP	MAX	UNIT
Input Operating						
Input Operating Range	V _{IN}		2.5		36	V
Input Supply Current	I _{IN}			70		uA
Under-Voltage Lockout Threshold	V _{IN_UVLO}			1.15		V
Under-Voltage Lockout Hysteresis	V _{UVLO_HYST}			0.02		V
OVP						
Internal Over-Voltage Trip Level	V _{IN_OVLO}	V _{IN} rising		5.85		V
		V _{IN} Falling		5.8		V
OVLO Preset Threshold Range	V _{OVLO_TH}			1.15		V
Adjustable OVLO Threshold Range			4		10	V
External OVLO Select threshold	V _{OVLO_SEL}			0.34		V
Switch On-Resistance	R _{DS(ON)}	V _{IN} =5V, I _{IN} =1A, T _A =25°C		125		mΩ
OVLO Input Leakage Current	I _{OVLO}	V _{OVLO} = V _{OVLO_TH}	-100		100	nA
Output power-on time	t _{ON}	V _{IN} =0→5V to output ON		10		ms
OVP recovery time	T _{ON(OVP)}	V _{IN} =10→5V to output ON		10		ms
Switch Turn-On Time	t _r	V _{IN} = 5V, R _L = 100Ω, C _{LOAD} = 100uF V _{OUT} from 10%, V _{IN} to 90% V _{IN}		0.35		ms
OVP active time	t _{OFF}	V _{IN} >V _{IN_OVLO} to V _{OUT} stop rising		60		ns
OCP						
Over current protection level	I _{OCP}			1.8		A
OTP						
OTP threshold	T _{OTP}			150		°C
OTP hysteresis	T _{OTP_HYS}			20		°C

¹ Depending on parts and PCB layout, characteristics may be changed.

² Stresses beyond those listed under absolute maximum ratings may cause permanent damage to the device. These are stress ratings only, and functional operation of the device at these or any other conditions beyond those indicated under recommended operating conditions is not implied. Exposure to absolute-maximum-rated conditions for extended periods may affect device reliability.

APPLICATION INFORMATION

1 USB On-The-Go (OTG) Operation

When used in an OTG application the HT4066 can provide power from OUT to IN. Initially, the OTG voltage applied at OUT will forward-bias the power switch bulk diode and present a voltage drop of approximately 0.7V between OUT and IN. The maximum current in this mode is limited by the thermal performance of the device and at an ambient temperature of +25°C.

$$I_{MAX} = 1.17W/0.7V = 1.67A$$

This is purely a transitional condition as once the voltage at IN exceeds the UVLO voltage of 1.15V and the Output power-on time of 10ms has elapsed, the main power switch will turn fully ON, significantly reducing the voltage drop from OUT to IN.

2 OVLO (Over-Voltage Lockout)

The HT4066 has a 1.15V (TYP) over-voltage trip threshold on the OVLO pin. With a resistor-divider on OVLO pin from VIN to GND, the over-voltage protection point of VIN can be adjusted between 4V and 10V. Once the OVLO pin voltage exceeds the OVLO select voltage, V_{OVLO_SELECT} (0.34V TYP), the comparator reads the OVLO pin voltage (a fraction of VIN) set by the external resistor-divider (R1, R2).

$R1 = 1M\Omega$ is a good starting value for minimum current consumption. Since V_{IN_OVLO} , V_{OVLO_THRESH} , and R1 are known, R2 can be calculated from the following formula:

$$V_{IN_OVLO} = V_{OVLO_TH} \times (1 + R1/R2) = 1.15V \times (1 + R1/R2)$$

When the OVLO pin is connected to GND, HT4066 provides 5.85V (TYP.) OVLO threshold trip voltage.

3 OCP (Over-Current Protection)

The OCP function ensures that the device will disconnect output from input when current through the switch exceed a preset value (default 1.8A). t_{ON} (TYP. 10ms) after the switch is turned off, the device will attempt to resume to connect output from input. If the current is decreased under 1.8A, the device will resume to connect output from input.

在 TOG 应用中, HT4066 可通过内部功率管的体二极管,将在 VOUT 处施加的 OTG 电压,传输至 VIN 端,并在 VOUT 和 VIN 之间呈现约 0.7V 的压降。其流过的最大电流主要取决于器件的热表现和环境温度。当环境温度为 25°C 时,

$$I_{MAX} = 1.17W/0.7V = 1.67A$$

这是一种过渡状态,因为一旦 VIN 处的电压超过 1.15V 的 UVLO 电压,并且经过 10ms 的启动时间,主电源开关将完全接通,从而显著降低从 OUT 到 IN 的电压降。

HT4066 在 OVLO pin 上的启动过压保护的阈值为 1.15V (TYP)。在 OVLO 上放置 VIN 到 GND 的分压电阻,过压保护值可设置到 4V~10V 之间。当 OVLO 引脚电压超过 V_{OVLO_SELECT} (0.34V TYP), OVLO 内部比较器读取 OVLO 的电压。

$R1 = 1M\Omega$ 是较为合理的取值,以得到较小的电流消耗。当 R1 值确定后, R2 值可通过下面的公式得到:

$$V_{IN_OVLO} = V_{OVLO_TH} \times (1 + R1/R2) = 1.15V \times (1 + R1/R2)$$

另外,当 OVLO 引脚接地, HT4066 的过压保护点则为固定的 5.85V (TYP.)。

OCP 功能确保当通过芯片的电流超过预设值(默认 1.8A)时,芯片将断开输出和输入。芯片断开以后,经过 t_{ON} (TYP. 10ms) 时间,尝试恢复导通,一旦电流降低到 1.8A 以下,芯片的输入端和输出端将恢复导通。

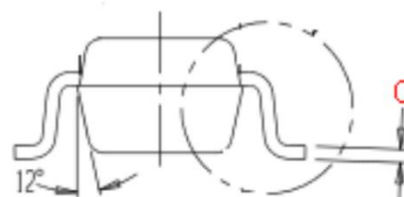
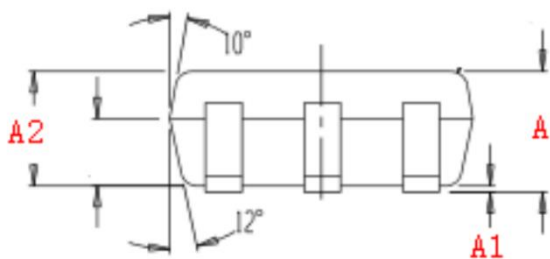
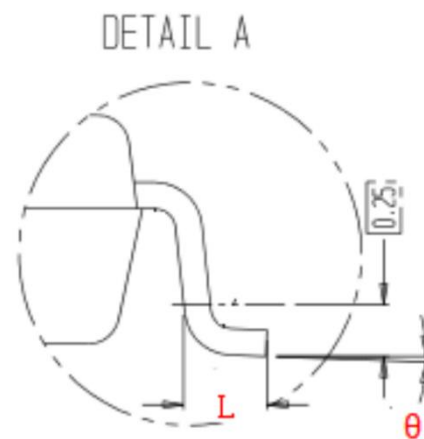
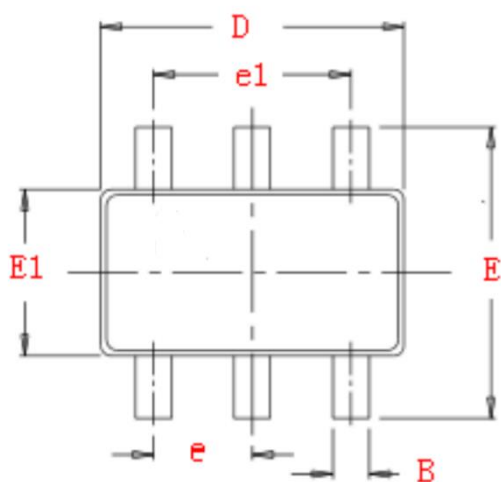
PACKAGE OUTLINE
ST (SOT23-6)

Symbol	Dimensions in Millimeters	
	Min.	Max.
A	1.06	1.26
A1	0.00	0.10
A2	1.00	1.20
C	0.13	
D	2.72	3.12
E	2.60	3.00
L	0.40	
B	0.30	0.50
e	0.95	
e1	1.90	
E1	1.40	1.80
θ	0°	10°

IMPORTANT NOTICE**注意**

Jiaxing Heroic Electronic Technology Co., Ltd (HT) reserves the right to make corrections, modifications, enhancements, improvements, and other changes to its products and services at any time and to discontinue any products or services. Customers should obtain the latest relevant information before placing orders and should verify that such information is current and complete.

嘉兴禾润电子科技有限公司（以下简称HT）保留对产品、服务、文档的任何修改、更正、提高、改善和其他改变，或停止提供任何产品和服务的权利。客户在下单和生产前应确保所得到的信息是最新、最完整的。

HT assumes no liability for applications assistance or customer product design. Customers are responsible for their products and applications using HT components.

HT对相关应用的说明和协助以及客户产品的板级设计不承担任何责任。

HT products are not authorized for use in safety-critical applications (such as life support devices or systems) where a failure of the HT product would reasonably be expected to affect the safety or effectiveness of that devices or systems.

HT的产品并未授权用于诸如生命维持设备等安全性极高的应用中。

The information included herein is believed to be accurate and reliable. However, HT assumes no responsibility for its use; nor for any infringement of patents or other rights of third parties which may result from its use.

本文中的相关信息是精确和可靠的，但HT并不对其负责，也不对任何可能的专利和第三方权利的侵害负责。

Following are URLs and contacts where you can obtain information or supports on any HT products and application solutions:

