

5V输入高效同步升压型1.6A双节锂电池充电器

High Efficiency, 1.6-A, 2-Cell Synchronous Boost Battery Charger for 5V Input

FEATURES

- High-efficiency 1.6-A, 800kHz Synchronous boost charger
92% charge efficiency at 5V adapter, 7.2V battery, 1A charge
- Support 5V input and 2-cell Li-Ion battery
Supports 4V-6V input voltage range with 16V absolute maximum input voltage rating
Adaptive input current limit: 4-4.3V input
OVP protection: 6.2V
- Charge voltage selectable: 8.4V / 8.7V
- Short current / trickle current / constant current / constant voltage charge mode
- Programmable charge current by external resistor
- Status indication
- Charge timeout, Thermal regulation, Over temperature protection, Input voltage UVLO and OVP, Output short circuit / overcurrent / OVP protection, NTC
- Pb-free Packages, ESOP8
- 高效的1.6A 800kHz开关模式同步升压充电器
5V输入、7.2V电池、1A充电电流下, 效率92%
- 支持5V输入, 给双节串联锂电池充电
4V-6V范围内正常工作 (最大极限16V); 4-4.3V自动调节输入电流; 6.2V过压保护
- 电池饱充电压8.4V和8.7V可选
- 短路涓流/预充涓流/恒流/恒压充电模式
- 充电电流由外部电阻灵活调节
- LED状态显示
- 保护: 充电超时、芯片过热反馈调节、过温关断、输入过压、输入欠压、输出过流、输出过压、输出短路、NTC温度保护等
- ESOP8封装

APPLICATIONS

- Portable Speakers · POS · 音箱 · POS机 · 电子烟
- E-Cigarette · Other portable electronic devices · 对讲机 · 其他便携式电子设备

ORDERING INFORMATION

Part Number	Package Type	Marking	Operating Temperature Range	MOQ/Shipping Package
HT4182SPET	ESOP8	HT4182SPE UVWXYZ ¹	-40°C~85°C	Tube / 100pcs
HT4182SPER	ESOP8	HT4182SPE UVWXYZ	-40°C~85°C	Tape and Reel / 2500pcs

¹ UVWXYZ is production tracking code

DESCRIPTION

HT4182 is a 5V input, two-cell synchronous boost Li-Ion battery charger. The input terminal has UVLO and OVP protection.

HT4182 adopts synchronous boost converter integrating switches to provide a high efficiency and small size solution. The charge current (max 1.6A) is programmable by an external resistor.

HT4182 integrates multiple protection function including: charge timeout, thermal regulation, over temperature protection, Input voltage UVLO and OVP, Output short circuit / overcurrent / OVP protection and NTC. Abnormal status can be indicated by STAT terminal.

The device is available in ESOP8 package.

HT4182是一款5V输入，升压模式的充电管理IC，适用于双节串联锂电池。其能自适应任意5V电源进行充电，并且由输入过压、欠压保护。

HT4182采用同步升压结构，内置MOSFET，外围元件简单。通过调节外部电阻，可任意调节充电电流，最大支持1.6A，效率超过90%。

HT4182具有多重保护功能：充电超时、芯片过热反馈调节、过温关断、输入过压、输入欠压、输出过流、输出过压、输出短路、NTC温度保护等。异常时，可通过LED进行异常指示。

该产品提供ESOP8封装。

TYPICAL APPLICATION

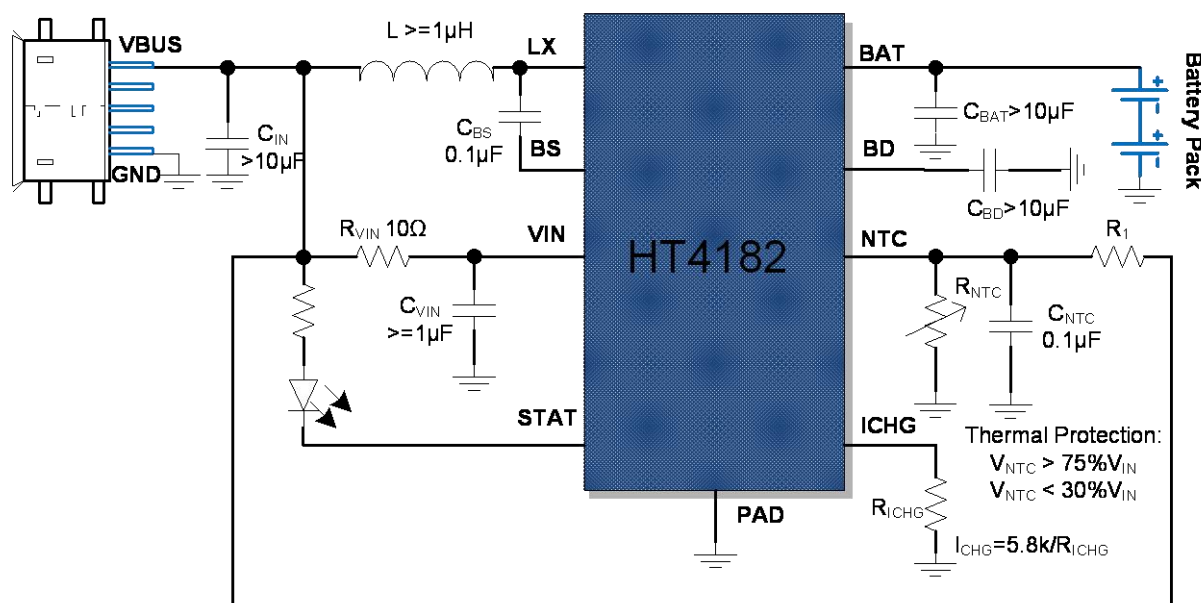

■ **TERMINAL CONFIGURATION**

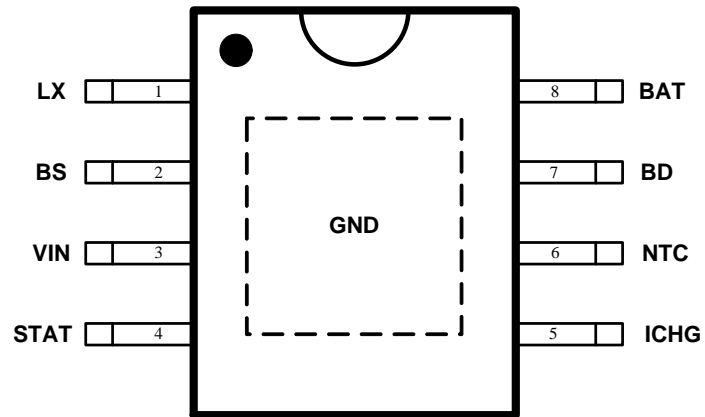

HT4182SPET, HT4182SPER

■ TERMINAL FUNCTION

Terminal No.	Name	Description
PAD	GND	Ground. 地。
1	LX	The switching node pin of the boost converter. 开关节点, 连接电感。
2	BS	Power supply for high-side MOSFET gate driver. 提供同步整流的栅极驱动, 串联 100nF 到 LX。
3	VIN	Power supply input. 电源输入端。
4	STAT	Status indicator. 状态显示端, 为开漏极结构。
5	ICHG	Charge current setting. 充电电流设置端, 外接电阻到地。
6	NTC	Temperature Qualification Voltage. 温度保护输入端, 接 NTC 电阻到地。
7	BD	Blocking MOSFET Connection. 连接至内部 Blocking FET, 接 10uF 电容到地。
8	BAT	Battery Power Connection. 电池连接端。

SPECIFICATIONS¹
Absolute Maximum Ratings²

PARAMETER	Symbol	MIN	MAX	UNIT
LX, BAT, BD, STAT, NTC, BS, VIN supply voltage range	V _{VDD}	-0.3	18.0	V
ICHG	V _{ICHG}	-0.3	3.6	V
LX current peak	I _{LIM}		2.5	A
Operating temperature range	T _A	-40	85	°C
Operating junction temperature range	T _J	-40	150	°C
Storage temperature range	T _{STG}	-50	150	°C

Recommended Operating Condition

PARAMETER	Symbol	CONDITION	MIN	TYP	MAX	UNIT
VIN supply voltage range	V _{IN}		4.0		5.5	V
LX, BAT, BD, STAT, BS voltage range	V _{DD}		0		16	V
ICHG, NTC voltage range	V _O		0		3.3	V
LX current peak	I _{LIM}				2.5	A
Operating temperature	T _a		-40	25	85	°C

Electrical Characteristics

PARAMETER	SYMBOL	CONDITION	MIN	TYP	MAX	UNIT
Quiescent Current						
Battery discharge current	I _{BAT}	Shutdown IC, V _{BAT} = 8.4V, V _{IN} = 0V		10		uA
Input quiescent current	I _{IN}	Disable charge, V _{IN} = 5V		1		mA
Bias Supply						
Supply voltage	V _{IN}		4		6	V
VIN under voltage lockout threshold	V _{UVLO}			4		V
VIN under voltage lockout hysteresis	ΔV _{UVLO}			0.4		V
Input overvoltage protection	V _{OV}			6.2		V
Input overvoltage protection hysteresis	ΔV _{OV}			0.7		V
Oscillator and PWM						
Switching frequency	f _{SW}			800		kHz
Max LS-FET on Duty	D _{MAX}			85		%
LS-FET minimum on time	T _{MINON}			100		ns
Power MOSFET						
RDS(ON) of LS-FET	R _{NFET_M}			80		mohm
RDS(ON) of HS-FET	R _{NFET_R}			40		mohm
RDS(ON) of Blocking FET	R _{NFET_M}			40		mohm
Voltage Regulation						
2-Cell regulation voltage	V _{BAT_REG}		8.36	8.4	8.44	V
2-Cell recharge voltage	V _{BATR}			8.2		V
Battery voltage rising threshold to start constant current charge mode	V _{TRK_R}			5.8		V
Battery voltage falling threshold to stop constant current charge mode	V _{TRK_F}			5.5		V
Battery voltage rising threshold to start trickle current charge mode	V _{SHORT_R}			2		V
Battery voltage falling threshold to stop trickle current charge mode	V _{SHORT_F}			1.8		V

¹ Depending on parts and PCB layout, characteristics may be changed.

² Stresses beyond those listed under absolute maximum ratings may cause permanent damage to the device. These are stress ratings only, and functional operation of the device at these or any other conditions beyond those indicated under recommended operating conditions is not implied. Exposure to absolute-maximum-rated conditions for extended periods may affect device reliability

Charge Current						
Charge current for constant current charge mode	I_{CC}			$5.8k/R_{ICHG}$		A
Charge current for trickle current charge mode	I_{TC}			20%		I_{CC}
Charge current in short mode	I_{SHORT}			10%		I_{CC}
Termination current	I_{TERM}			10%		I_{CC}
Battery Voltage OVP						
Output voltage OVP threshold	V_{OVP}		105%	110%	115%	V_{CV}
Adaptive Current Limit Function						
VIN Voltage threshold	V_{IN_th}			4.3		V
Voltage reference threshold of SEN terminal	V_{SEN_th}			1.1		V
Timer						
Trickle current charge timeout	T_{TC}			50		min
Battery Thermal Protection NTC						
Under temperature protection	UTP		70%	75%	80%	VIN
Under temperature protection hysteresis		Falling edge		5%		
Over temperature protection	OTP		28%	30%	32%	
Over temperature protection hysteresis		Rising edge		3%		
Thermal Regulation and Thermal Shutdown						
Thermal regulation threshold	T_{REG}	Rising threshold		125		°C
Thermal regulation foldback ratio				0.25		I_{CC}
Thermal shutdown temperature	T_{SD}	Rising threshold		160		°C
Thermal shutdown temperature	T_{SDHYS}			30		°C

TYPICAL OPERATING CHARACTERISTICS

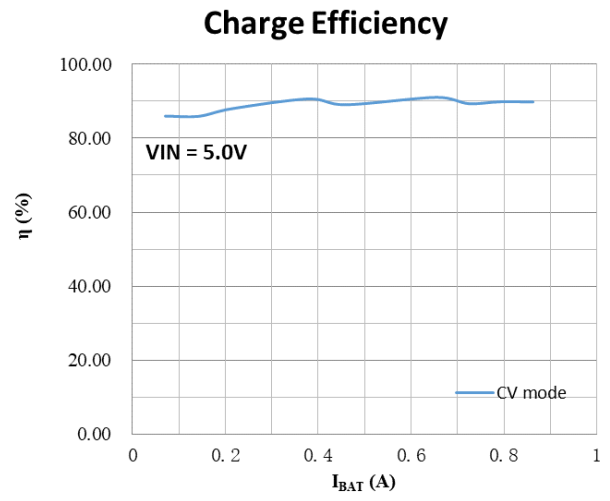
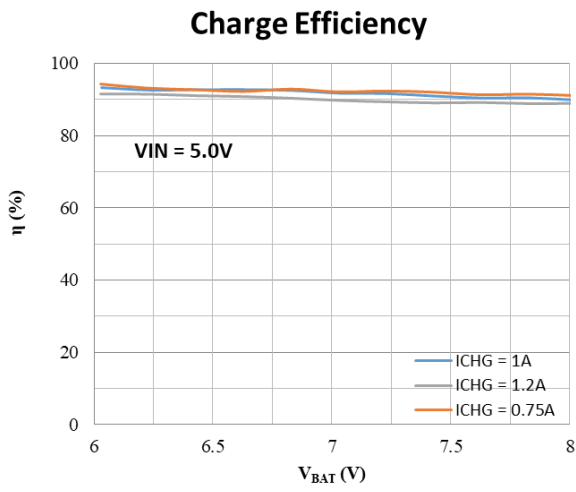

APPLICATION INFORMATION
1. Charge process

Figure 1 Charge Process

2. Charge current

The charge current can be set through the resistor R_{ICHG} pulled from ICHG pin to Ground. The charge current $I_{CHG} = 1 \times I_{CC} = 1 \times \frac{5.8K}{R_{ICHG}}$. Once the die temperature is higher than 125°C , the voltage of VIN is lower than 4.3V, or the peak boost switch current reaches the limited value, the charge current will be adaptively decreased. Do not use R_{ICHG} smaller than 3.2k.

在 ICHG 引脚端对地下拉电阻 R_{ICHG} ，可设置充电最大电流，充电电流 $I_{CHG} = \frac{5.8K}{R_{ICHG}}$ 。在高温环境、VIN 电压低于 4.3V，升压开关峰值电流达到限定值等情况下，充电电流会减小。 R_{ICHG} 电阻不要小于 3.2k。

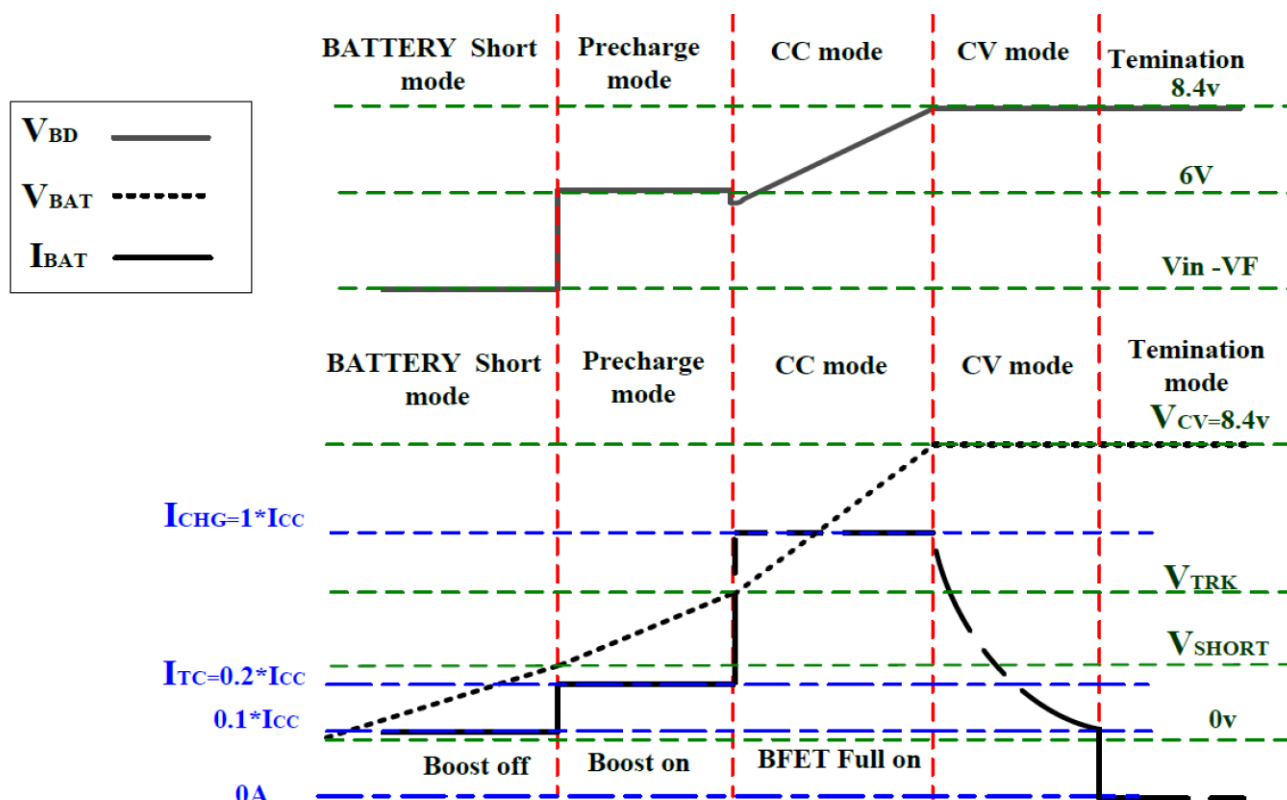
3. Short Mode

If V_{BAT} is lower than V_{SHORT} (Typically 2V) and the input power is normally supplied, the HS-FET turns off, Blocking FET works in linear mode, and the battery will be charged through body diode of HS-FET by $10\% I_{CC}$.

在输入电源正常接入时，若 V_{BAT} 小于 V_{SHORT} (典型值 2V)，HS-FET 将被关闭，芯片通过 HS-FET 二极管充电，Blocking FET 进入线性模式，并提供 $10\% I_{CC}$ 的电流给电池充电。

4. Pre-charge / Trickle charge mode

If V_{BAT} is higher than V_{SHORT} (Typically 2V) but lower than the threshold of trickle charge (Typically 6V) and the input power is normally supplied, the boost converter activates and regulates the V_{BD} at 6V, and the blocking FET works in linear mode, the charge current will be $20\% I_{CC}$. If the duration of trickle charge exceeds 50min, and the V_{BAT} is still lower than the threshold of trickle charge, the charge mode turns off, abnormal status is indicated through STAT.

在输入电源正常接入时，当电池电压处于 V_{SHORT} 和 V_{TRK} 之间，升压启动， V_{BD} 设置在 6V 进入预充电模式，Blocking FET 仍旧处于线性模式，并提供 $20\% I_{CC}$ 的电流给电池充电。如果预充电模式时间超过 50 分钟，而电池电压无法达到 V_{TRK} 阈值，充电模式将会关闭并在 STAT 上指示异常。

5. Constant current charge mode

If V_{BAT} is higher than the threshold of trickle charge (Typically 6V) and the input power is normally supplied, the device works in constant current charge mode, the boost converter remains active, the charge current is $I_{CHG} = \frac{5.8K}{R_{ICHG}}$.

6. Constant voltage charge mode

If V_{BAT} reaches threshold of constant voltage charge (Typically 8.4V) and the input power is normally supplied, the device works in constant voltage charge mode, the boost converter remains active, the charge current is decreased consequently.

7. Charge termination

Once the charge current is lower than the termination current threshold I_{TERM} (typically 10% I_{CC}), STAT is high-Z to indicate the battery is fully charged. However, the charge current will continue with a value around 50mA and it will last around 40 minutes. After 40 minutes, all FETs are turned off, and the charge current falls to zero. Once the battery voltage falls below 8.2V (Typ), the chip will resume another charge cycle.

8. Status indicator

- (1) Charge-in-process, STAT is low.
- (2) Charge termination, STAT is high-Z.
- (3) Fault, STAT is alternatively switched between low and high-Z with 1Hz frequency.

Fault condition includes: VIN OVP, UTP / OTP in NTC terminal, and charge timeout.

An LED diode can be placed between VIN and STAT, so that the LED can indicate the status:

- (1) Charge-in-process, LED on.
- (2) Charge termination, LED off.
- (3) Fault, LED flashing.

9. Protection Principle

When the input over voltage protection, the output over voltage protection, the thermal protection or the timeout protection happens, the LS-FET of the boost charger is turned off immediately. The HS-FET and the blocking FET are turned off later when the current is down to zero.

When the V_{BAT} is lower than V_{SHORT} , the short circuit protection happens, the LS-FET is turned off firstly, the blocking FET enters linear mode with 10% I_{CC} charging current. When V_{BAT} recovers back to be higher than V_{SHORT} , the boost charger restarts to work and regulates V_{BD} at 6V. The linear charge current is increased from 10% I_{CC} to 29% I_{CC} current.

当电池电压超过 V_{TRK} 阈值，芯片进入恒流充电模式，升压仍旧启动，充电电流 $I_{CHG} = \frac{5.8K}{R_{ICHG}}$ 。

当电池电压达到恒压充电 V_{CV} 阈值(典型 8.4V)，芯片进入恒压充电模式，升压仍旧启动，充电电流逐渐减小。

在恒压充电模式，芯片监控充电电流的大小，当充电电流小于充电停止电流 I_{TERM} (典型值 10% I_{CC}) 时，STAT 输出为高阻表示电池充电，但此时芯片充电不完全停止，仍以约 50mA 电流继续充电约 40min 后，才彻底停止充电，关闭芯片，充电电流为 0。当电池电压跌落至 8.2V 以下，系统将重新给电池充电。

- (1) 充电中：STAT 拉低；
- (2) 充电完成：STAT 高阻；
- (3) 异常状态：STAT 高低交替，频率 1Hz。

异常状态包括：VIN OVP, NTC 发生高温或低温关断，充电超时。

可在 VIN 与 STAT 间连接 LED，则 LET 可显示状态：

- (1) 充电中：LED 常亮；
- (2) 充电完成：LED 灯灭；
- (3) 异常状态：LED 闪烁。

当输入过压保护、输出过压保护、过温保护启动时，LS-FET 关闭，随后当电流降至 0，HS-FET 和 blocking FET 关闭。

当 V_{BAT} 低于 V_{SHORT} ，短路保护启动，LS-FET 关闭，blocking FET 进入线性模式，充电电流 10% I_{CC} 。当 V_{BAT} 高于 V_{SHORT} 后，升压启动， V_{BD} 设置在 6V 进入预充电模式，Blocking FET 仍旧处于线性模式，并提供 20% I_{CC} 的电流给电池充电。

10. Adaptive input current limit

HT4182 has adaptive input current limit function. Once the device starts to charge, the output charging current I_{CC} is ramped up softly and the VIN drop is monitored simultaneously.

When the input voltage drop is too large and VIN is lower than V_{IN_DPM} (typically 4.3V), the charging current is decreased so that the VIN would recover back.

11. NTC terminal

HT4182 monitors battery temperature by measuring NTC voltage. The controller triggers the UTP or OTP when the voltage of NTC reaches the threshold of UTP (V_{HTF}) or OTP (V_{LTF}). The temperature sensing network is showed as below.

Choose R_1 and R_{NTC} to program the proper UTP and OTP points. If NTC function is not used, $R_1 = 100k$, $R_{NTC} = 100k$.

为防止适配器超出负荷能力，当 VIN 电压小于 4.3V 时，充电电流将会减小，使 VIN 可以钳位在 4.3V 的电压。

电池温度由 NTC 引脚的电压测量得到，建议在 NTC 引脚和地之间接一个 100nF 的瓷片电容。NTC 的电压由一个 NTC 电阻和外部的电阻分压器得到，芯片比较 NTC 的电压，当电压处于 OTP (V_{LTF}) 和 UTP (V_{HTF}) 之间时，允许充电。如果电池的温度超出这个区间，芯片停止充电，直到电池温度回到 OTP (V_{LTF}) 和 UTP (V_{HTF}) 之间。

选择合适的 R_1 和 R_{NTC} 值，以达到 OTP 和 UTP 点。若 NTC 功能不适用， $R_1=100k$, $R_{NTC}=100k$ 。

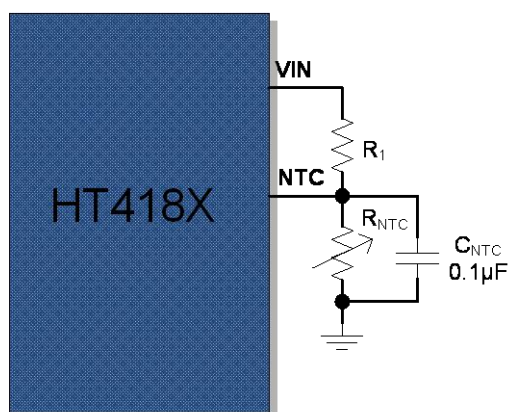

Figure 2 NTC Terminal Configuration

12. Application information

(1) Input capacitor C_{IN}

The ripple current through input capacitor is greater than

$$I_{CIN_RMS} = \frac{V_{IN} \times (V_{OUT} - V_{IN})}{2\sqrt{3} \times L \times F_{SW} \times V_{OUT}}$$

X5R or X7R ceramic capacitors with greater than 4.7uF capacitance are recommended to handle this ripple current.

(2) Output capacitor C_{OUT}

The output capacitor is selected to handle the output ripple noise requirements. This ripple voltage is related to the capacitance and its equivalent series resistance (ESR). For the best performance, it is recommended to use X5R or better grade low ESR ceramic capacitor. The voltage rating of the output capacitor should be higher than the maximum output voltage. The minimum required capacitance can be calculated as:

$$C_{OUT} = \frac{I_{CC}}{F_{SW} \times V_{OUT} \times V_{RIPPLE}}$$

V_{RIPPLE} is the peak to peak output ripple, I_{CC} is the setting charge current.

For HT4182, output capacitor is paralleled by C_{BD} and C_{BAT} , for smaller output ripple noise, each capacitor with greater than 10uF capacitance is recommended.

(1) 输入电容 C_{IN}

输入电容的流纹波超过

$$I_{CIN_RMS} = \frac{V_{IN} \times (V_{OUT} - V_{IN})}{2\sqrt{3} \times L \times F_{SW} \times V_{OUT}}$$

建议使用超过4.7uF的瓷片电容处理这个电流纹波。

(2) 输出电容 C_{IN}

输出电容用来处理的压纹波需求，该电压纹波和输出容的值等效串联阻（ESR）相关。建议使用X5R或者更低ESR的电容，来达到比较好的效果。电容耐压值需高于最大输出电压。最小的输出电容值可计算如下：

$$C_{OUT} = \frac{I_{CC}}{F_{SW} \times V_{OUT} \times V_{RIPPLE}}$$

其中 V_{RIPPLE} 是输出纹波峰值， I_{CC} 是设定的充电电流。对于HT4182，输出电容是 C_{BD} 和 C_{BAT} 的并联。建议使用两个超过10uF瓷片电容。

(3) Inductance L

There are several considerations in choosing this inductor:
Choose the inductance to provide the desired ripple current.
It is suggested to choose the ripple current to be about 40% of the average input current. The inductance is calculated as:

$$L = \left(\frac{V_{IN}}{V_{OUT}}\right)^2 \times \frac{(V_{OUT} - V_{IN})}{I_{CC} \times F_{SW} \times 40\%}$$

Where F_{SW} is the switching frequency and I_{CC} is the setting charge current.

The HT4182 is quite tolerant of different ripple current amplitude. Consequently, the final choice of inductance can be slightly off the calculation value without significantly impacting the performance.

The saturation current rating of the inductor must be selected to be greater than the peak inductor current under full load conditions.

$$I_{SAT} > \frac{V_{OUT}}{V_{IN}} \times I_{CC} + \left(\frac{V_{IN}}{V_{OUT}}\right)^2 \times \frac{(V_{OUT} - V_{IN})}{2 \times F_{SW} \times L}$$

The DCR of the inductor and the core loss at the switching frequency must be low enough to achieve the desired efficiency requirement. It is desirable to choose an inductor with $DCR < 10\text{mohm}$ to achieve a good overall efficiency.

(3) 电感L

在选择电感时需考虑:

选择电感值来设定流纹波。建议把电流纹波设置在平均电流的40%，电感值计算如下:

$$L = \left(\frac{V_{IN}}{V_{OUT}}\right)^2 \times \frac{(V_{OUT} - V_{IN})}{I_{CC} \times F_{SW} \times 40\%}$$

其中 F_{SW} 是开关频率， I_{CC} 是设定的充电电流。不同纹波对HT4182的影响很小，因此最终的电感值选择可以和计算有所偏差。

电感的饱和电流必须比满负荷工作时的尖峰电流大。

$$I_{SAT} > \frac{V_{OUT}}{V_{IN}} \times I_{CC} + \left(\frac{V_{IN}}{V_{OUT}}\right)^2 \times \frac{(V_{OUT} - V_{IN})}{2 \times F_{SW} \times L}$$

考虑到效率的需求，电感的DCR需要足够小，建议小于10mohm。

14. PCB Layout

HT4182

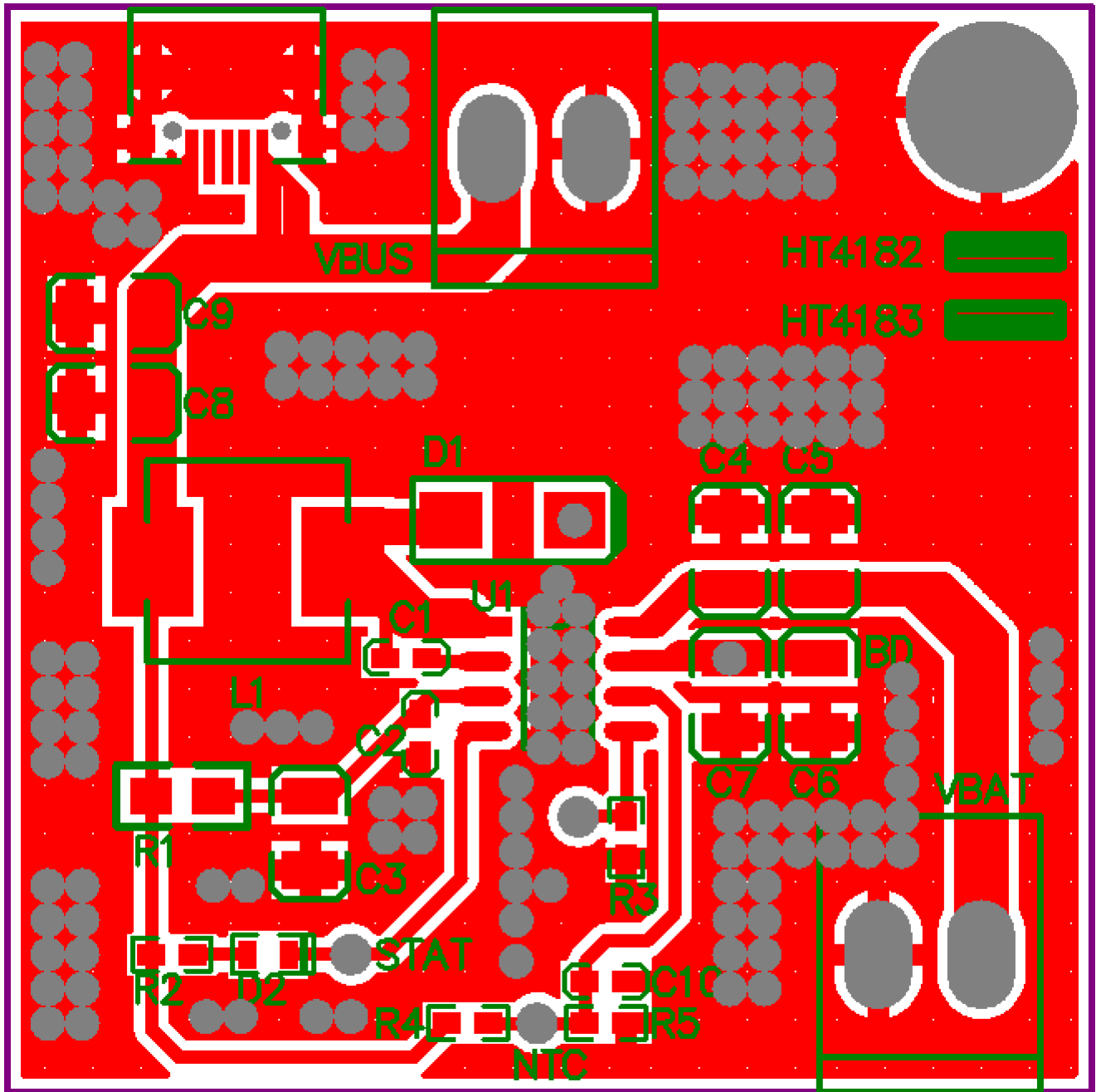

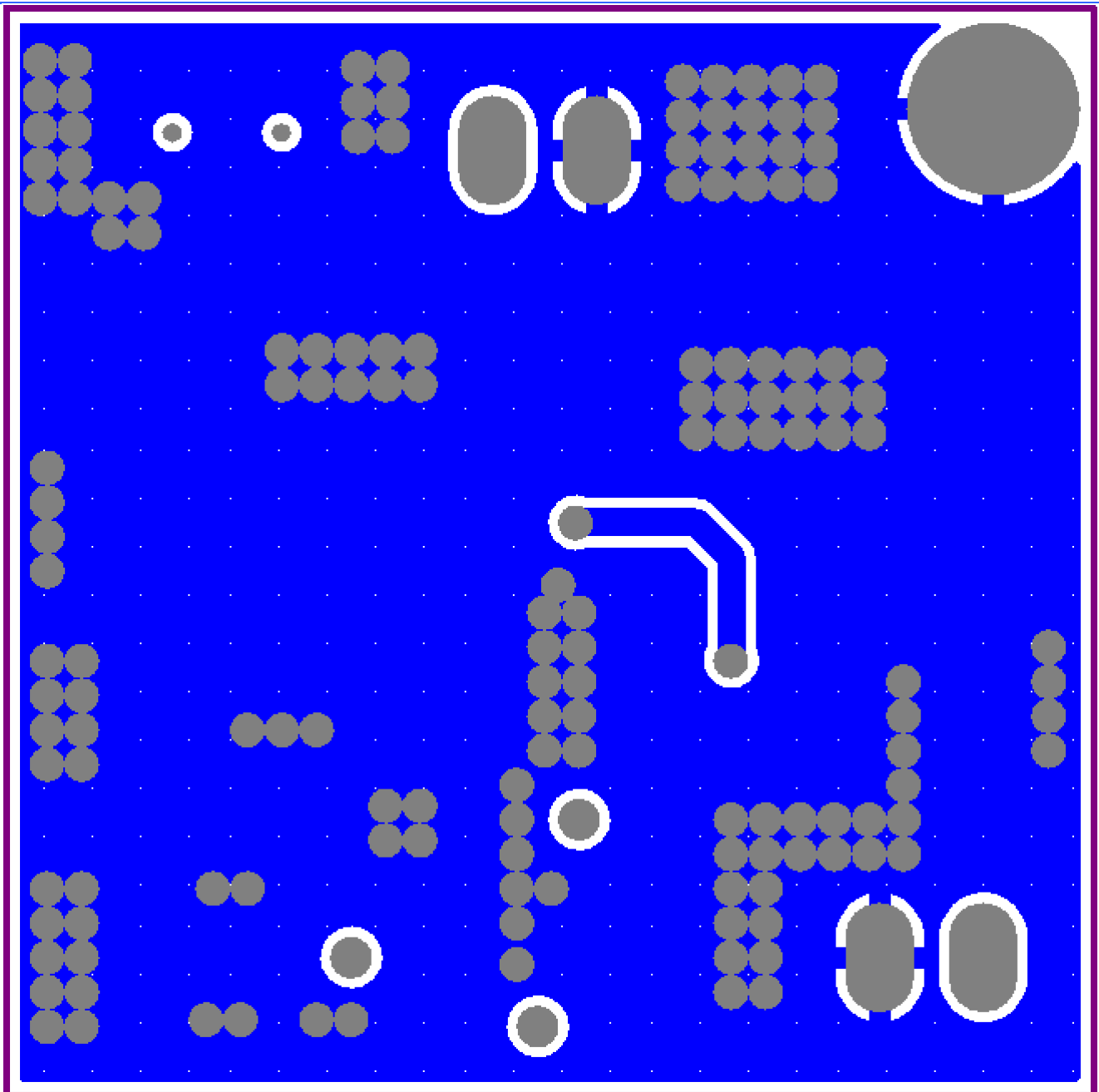

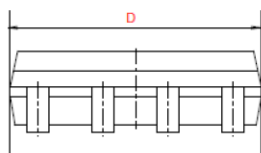
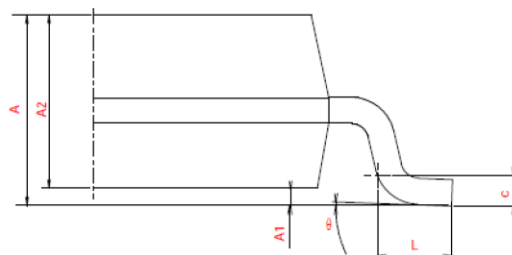
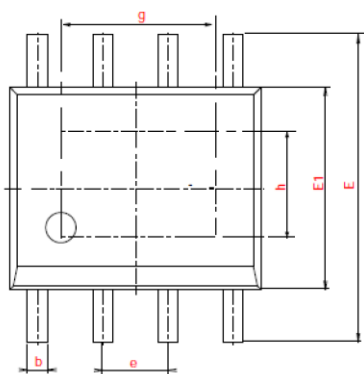
PACKAGE OUTLINE
ESOP8

名称	尺寸	
	Min	Max
A	1.45	1.75
A1	0.05	0.15
A2	1.35	1.55
b	0.3	0.5
c	0.22	0.28
D	4.7	5.1
E	5.8	6.2
E1	3.85	4.05
L	0.4	1.27
θ	0°	8°
e	1.270 (BSC)	
h	2.4	
g	3.3	

IMPORTANT NOTICE**注意**

Heroic Electronic Technology (Jiaxing) Co., Ltd (HT) reserves the right to make corrections, modifications, enhancements, improvements, and other changes to its products and services at any time and to discontinue any products or services. Customers should obtain the latest relevant information before placing orders and should verify that such information is current and complete.

禾润电子科技(嘉兴)股份有限公司(以下简称HT)保留对产品、服务、文档的任何修改、更正、提高、改善和其他改变,或停止提供任何产品和服务的权利。客户在下单和生产前应确保所得到的信息是最新、最完整的。

HT assumes no liability for applications assistance or customer product design. Customers are responsible for their products and applications using HT components.

HT对相关应用的说明和协助以及客户产品的板级设计不承担任何责任。

HT products are not authorized for use in safety-critical applications (such as life support devices or systems) where a failure of the HT product would reasonably be expected to affect the safety or effectiveness of that devices or systems.

HT的产品并未授权用于诸如生命维持设备等安全性极高的应用中。

The information included herein is believed to be accurate and reliable. However, HT assumes no responsibility for its use; nor for any infringement of patents or other rights of third parties which may result from its use.

本文中的相关信息是精确和可靠的,但HT并不对其负责,也不对任何可能的专利和第三方权利的侵害负责。

Following are URLs and contacts where you can obtain information or supports on any HT products and application solutions:

下面是可以联系到我公司的相关链接和联系方式:

禾润电子科技(嘉兴)股份有限公司
Jiaxing Heroic Electronic Technology Co., Ltd.

地址: 浙江省嘉兴市凌公塘路3339号JRC大厦A座三层

Add: A 3rd floor, JRC Building, No. 3339, LingGongTang Road, Jiaxing, Zhejiang Province

Sales: 0573-82585539, sales@heroic.com.cn

Support: 0573-82586151, support@heroic.com.cn

Fax: 0573-82585078

Website: www.heroic.com.cn; wap.heroic.com.cn

Wechat MP: HEROIC_JX

请及时关注禾润官方微信公众号,随时获取最新产品信息和技术资料!

