

Features

- Operating Voltage (V_{DD}): 3.3V~5.5V
- UART pin Voltage (V_{DDIO}): 1.8V~ V_{DD} (Less than V_{DD} voltage)
- Power down and wake-up functions to reduce power consumption
- Fully integrated 12MHz oscillator with 0.25% accuracy for all USB modes which requires no external components
- USB interface
 - ♦ USB 2.0 Full Speed compatible
 - ♦ Implements USB protocol composite device:
 - Communication Device Class (CDC) for communications and configuration
 - Human Interface Device (HID) for user configure USB VID, PID and device description strings
 - ♦ Internal 1.5k Ω pull-high resistor on D+ pin
- Fully-duplex Universal Asynchronous Receiver and Transmitter Interface – UART
 - ♦ Supports Baud Rate up to 3Mbps
 - ♦ Supports maximum 128 bytes transmit buffer and 128 bytes receive buffer
 - ♦ UART Data formats supported:
 - Data bits: 8
 - Stop bits: 1 and 2
 - Parity: odd, even, no parity
 - ♦ Supports RTS/CTS pins for auto flow control
 - ♦ Supports RX pin resume signal to request a remote wake-up
 - ♦ Supports VDDIO pin for UART pins power supply
- Supports standard Windows[®] drivers for Virtual Com Port (VCP): Windows XP (SP2), Vista, Widows 7 & Windows 8 (only an INF file is required), Windows 10
- Supports Android 4.0 or later version and Mac OS X
- Integrated 256 bytes true EEPROM for user memory
- Package types: 8-pin SOP, 10-pin SOP/MSOP, 16-pin NSOP

General Description

The HT42B534-x device is a high performance USB to UART bridge controller with fully integrated USB and UART interface functions, designed for applications that communicate with various types of UART. The device includes a USB 2.0 full speed compatible interface which is used for PC communication. The device also includes a fully integrated high speed oscillator which is used as clock source for the USB and UART baud rate generator. The baud rate generator can support up to 3Mbps of baud rate for the UART interface.

USB Bridge IC Naming Rules

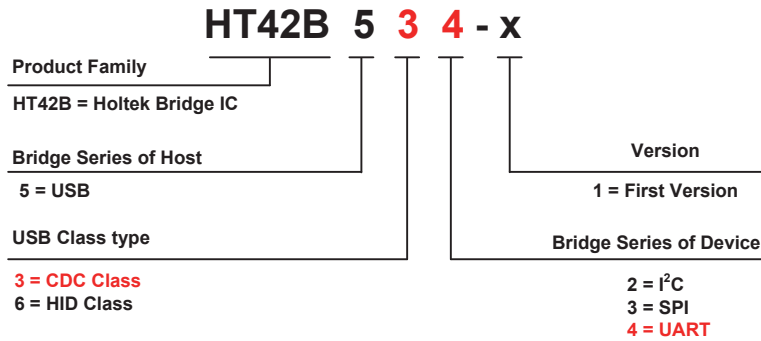

Selection Table

Part No.	Description	VDD	USB	Virtual COM	HID	FIFO/Buffer	Interface Data Rate	I/O VDD	Package
HT42B532-x	USB to I ² C Bridge	3.3V~5.5V	Full-Speed	√	—	TX: 62 bytes RX: 62 bytes	Up to 400kHz	√	8SOP 10MSOP
HT42B533-x	USB to SPI Bridge			√	—	TX: 128 bytes RX: 128 bytes	Up to 8MHz	√	10MSOP 16NSOP
HT42B534-x	USB to UART Bridge			√	—	TX: 128 bytes RX: 128 bytes	Up to 3Mbps Baud	√	8SOP 10SOP/MSOP 16NSOP
HT42B564-x	USB (HID) to UART Bridge			—	√	TX: 32 bytes RX: 32 bytes	Up to 115.2kbps Baud	√	10SOP

Block Diagram

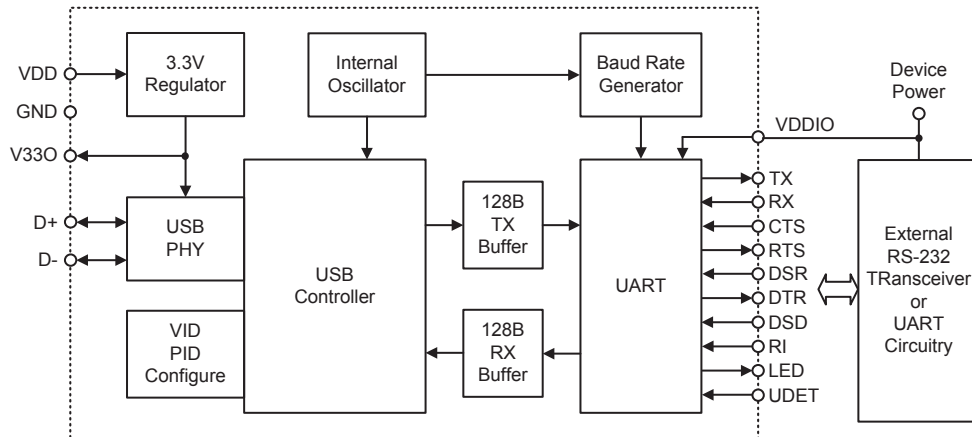

Pin Assignment

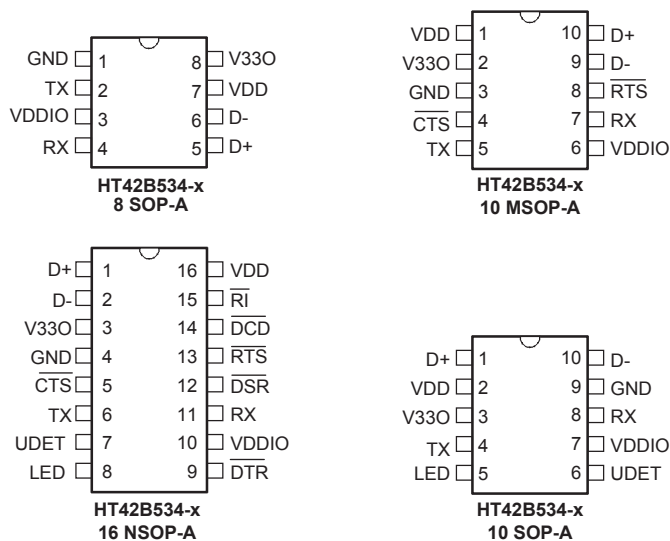

Package Type	Marking
8SOP	HT42B534-x
10SOP	HT42B534-x
10MSOP	B534-x
16NSOP	HT42B534-x

Note: x=1 for version number.

Pin Description

As the Pin Description table applies to the package type with the most pins, not all of the listed pins may be present on package types with smaller numbers of pins.

Pin Name	Type	Description
D+	I/O	USB D+ Line
D-	I/O	USB D- Line
TX	O	Asynchronous data output (UART Transmit)
RX	I	Asynchronous data input (UART Receive)
CTS	I	Clear To Send control input, active low
RTS	O	Ready to Send control output, active low
DSR	I	Data Set Ready control input, active low
DTR	O	Data Terminal Ready control output, active low
DCD	I	Data Carrier Detect control input, active low
RI	I	Ring Indicator control input, active low
LED	O	TX/RX signal LED indication, active low
UDET	I	USB plug in/out detect pin, only for 10-pin SOP package
V33O	O	3.3V regulator output
VDDIO	PWR	Positive power supply for TX/RX/CTS/RTS/DSR/DTR/DCD/RI pins
VDD	PWR	Positive power supply, USB bus power
GND	PWR	Negative power supply, ground

Absolute Maximum Ratings

Supply Voltage	$V_{SS}-0.3V$ to $V_{SS}+6.0V$	I_{OH} Total	-80mA
Input Voltage	$V_{SS}-0.3V$ to $V_{DD}+0.3V$	I_{OL} Total	80mA
Storage Temperature	-50°C to 125°C	Total Power Dissipation	500mW
Operating Temperature	-40°C to 85°C		

Note: These are stress ratings only. Stresses exceeding the range specified under “Absolute Maximum Ratings” may cause substantial damage to this device. Functional operation of this device at other conditions beyond those listed in the specification is not implied and prolonged exposure to extreme conditions may affect devices reliability.

D.C Characteristics

Ta=25°C

Symbol	Parameter	Test Conditions		Min.	Typ.	Max.	Unit
		V _{DD}	Conditions				
V _{DD}	Operating Voltage	—	—	3.3	—	5.5	V
V _{DDIO}	UART Pins VDDIO Input Voltage	—	—	1.8	—	V _{DD}	V
I _{DD}	Operating Current	5V	No load	—	11	16	mA
I _{SUS}	Suspend Current (USB)	5V	Suspend mode, No load, USB on, other peripherals off	—	360	450	μA
I _{STB}	Standby Current (Non-USB) for 10-pin SOP package only	3V	Standby mode, No load, USB Plug-out, other peripherals off, VDD power is from VDDIO	—	0.1	1.0	μA
V _{IL}	Input Pins Input Low Voltage	—	—	0	—	0.2V _{DDIO}	V
V _{IH}	Input Pins Input High Voltage	—	—	0.8V _{DDIO}	—	V _{DDIO}	V
I _{OL}	I/O Pins Sink Current	3V	V _{OL} = 0.1V _{DDIO}	4	8	—	mA
		5V		10	20	—	mA
I _{OH}	I/O Pins Source Current	3V	V _{OH} = 0.9V _{DDIO}	-2	-4	—	mA
		5V		-5	-10	—	mA
R _{PH}	I/O Pins Pull-high Resistance	3V	—	20	60	100	kΩ
		5V	—	10	30	50	kΩ
I _{LEAK}	Input Leakage Current	3V	V _{IN} = V _{DD} or V _{IN} = V _{SS}	—	—	±1	μA
		5V		—	—	±1	μA
V _{V330}	3.3V Regulator Output Voltage	5V	I _{V330} = 70mA	3.0	3.3	3.6	V
R _{UDP1}	Pull-high Resistance between D+ and V330	3.3V	—	-5%	1.5	+5%	kΩ

A.C Characteristics

Ta=25°C

Symbol	Parameter	Test Condition		Min.	Typ.	Max.	Unit
		V _{DD}	Condition				
f _{HIRC}	High Speed Internal RC Oscillator	3.3V~5.5V	USB mode	-0.25%	12	+0.25%	MHz
t _{SST}	System Start-up Timer Period	—	RX pin Wake-up from power down mode	16	—	—	t _{HIRC}
t _{RSTD}	System Reset Delay Time	—	Power-on reset	25	50	100	ms

Power-on Reset Characteristics

Ta=25°C

Symbol	Parameter	Test Conditions		Min.	Typ.	Max.	Unit
		V _{DD}	Conditions				
V _{POR}	V _{DD} Start Voltage to Ensure Power-on Reset	—	—	—	—	100	mV
RR _{POR}	V _{DD} Rising Rate to Ensure Power-on Reset	—	—	0.035	—	—	V/ms
t _{POR}	Minimum Time for V _{DD} Stays at V _{POR} to Ensure Power-on Reset	—	—	1	—	—	ms

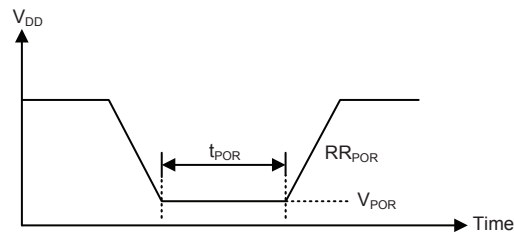

USB Interface

The USB interface, being USB 2.0 full-speed compatible, is a 4-wire serial bus that allows communication between a host device and up to 127 max peripheral devices on the same bus. A token based protocol method is used by the host device for communication control. Other advantages of the USB bus include live plugging and unplugging and dynamic device configuration. As the complexity of USB data protocol does not permit comprehensive USB operation information to be provided in this datasheet, the reader should therefore consult other external information for a detailed USB understanding.

Power Planes

There are two power planes for the device and they are the USB bus power input (VDD) and 3.3V regulator output (V330).

For the USB SIE VDD will supply all circuits related to USB SIE and be sourced from pin “VDD”. Once the USB is removed from the USB and there is no power in the USB BUS, the USB SIE circuit is no longer operational.

USB Interface Operation

To communicate with an external USB host, the internal USB module has external pins known as D+ and D- along with the 3.3V regulator output V330. A Serial Interface Engine (SIE) decodes the incoming USB data stream and transfers it to the correct endpoint buffer memory known as the FIFO. The USB module has 4 endpoints, EP0 ~ EP3. The endpoint 0 supports the Control transfer while the endpoint 1 ~ endpoint 3 support the Interrupt or Bulk transfer. The HT42B534-x Bridge IC supports the USB Communication Device Class (CDC) for communications and configuration.

Endpoint	Transfer Type
0	Control
1	Interrupt
2	Bulk Out
3	Bulk In

USB Endpoint Transfer Type

If there is no signal on the USB bus for over 3ms, the USB device will enter the suspend mode. The device enters the suspend state to meet the requirements of the USB suspend current specification. When the resume signal is asserted by the USB host, the device will be woken up and leave the suspend mode.

As the USB device has a remote wake-up function, the USB device can wake up the USB host by sending a remote wake-up pulse. Once the USB host receives a remote wake-up signal from the USB device, the host will send a resume signal to device.

USB VID and PID Configuration

The device has configured the default Vendor ID (VID:0x04D9), Product ID (PID:0xB534) and product description strings of “USB to UART Bridge”. The user can update the Vendor ID, Product ID, product description strings and remote wake-up setting using their application program.

This device has been configured to the default USB configuration data as shown in the following table.

Parameter	Value (hex)
USB Vendor ID (VID)	0x04D9
USB Product ID (PID)	0xB534
Remote wake-up	Default disable
Manufacturer Name	Holtek
Product Description	USB to UART Bridge
Serial Number	0000

UART Interface

The HT42B534-x contains an integrated full-duplex asynchronous serial communications UART interface that enables communication with external devices that contain a serial interface. The UART function has many features and can transmit and receive data serially by transferring a frame of data with eight data bits per transmission as well as being able to detect errors when the data is overwritten or incorrectly framed. The UART function possesses its own internal interrupt which can be used to indicate when a reception occurs or when a transmission terminates.

The integrated UART function contains the following features:

- Full-duplex, asynchronous communication
- 8 bits character length
- Even, odd or no parity options
- One or two stop bits
- Baud rate generator with prescaler
- 128-byte Deep FIFO Transmit Data Buffer
- 128-byte Deep FIFO Receive Data Buffer
- RX pin wake-up function
- UART pins power supply by VDDIO pin

UART External Pin

To communicate with an external serial interface, the internal UART has two external pins known as TX and RX. The TX and RX pins are the UART transmitter and receiver pins respectively.

UART Data Transfer Scheme

The data will be transferred to the Transmit Shift Register from where it will be shifted out, LSB first, onto the TX pin at a rate controlled by the Baud Rate Generator. Data to be received by the UART is accepted on the external RX pin, from where it is shifted in, LSB first, to the Receiver Shift Register at a rate controlled by the Baud Rate Generator. The UART interface provides a 128 byte deep FIFO transmit data buffer and a 128 byte deep FIFO receive data buffer for applications.

For data transfer, the UART function utilises a non-return-to-zero, more commonly known as NRZ, format. This is composed of one start bit, eight data bits and one or two stop bits. Parity is supported by the UART hardware and can be setup to be even, odd or no parity. For the most common data format, 8 data bits along with no parity and one stop bit, denoted as 8, N, 1, is used as the default setting, which is the setting at power-on.

The following diagram shows the transmit and receive waveforms for an 8-bit data format.

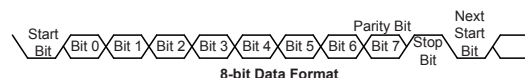

Baud Rate Generator

To setup the speed of the serial data communication, the UART function contains its own dedicated baud rate generator. The default UART baud rate is 9600bps and it can be controlled by the application program.

The baud rate and miss rate table:

Baud Rate	Real Rate	Miss Rate (%)
2400	2403.846154	0.16
4800	4807.692308	0.16
9600	9603.841537	0.04
19200	19207.68307	0.04
38400	38461.53846	0.16
57600	57692.30769	0.16
115200	115384.6154	0.16
230400	230769.2308	0.16
460800	457142.8571	0.79
1700000	1714285.714	0.84
2300000	2285714.286	0.62
3400000	3428571.429	0.84

UART Power Down and Wake-up

If the USB host sends a suspend signal to the HT42B534-x USB device, it will enter the suspend mode. It is recommended to ensure that the UART data transmission or reception has been finished before the device enters the suspend mode.

The UART function contains a receiver RX pin wake-up function. A falling edge on the RX pin will wake up the device from the suspend mode.

Application Program Demo

Holtek USB Bridge Program

Holtek provides an application program to setup the HT42B534-x Bridge IC for USB to UART data communication. The application program carries the name “Holtek USB Bridge Program”. The application program function contains two blocks, the first block is for the customer vendor ID, product ID and product information update, the second block is for the USB to UART application settings. The USB to UART setting block can be used to configure the baud rate, data, stop bits, parity, flow control and data transmit/receive demo.

The main figure for the program update is as follows:

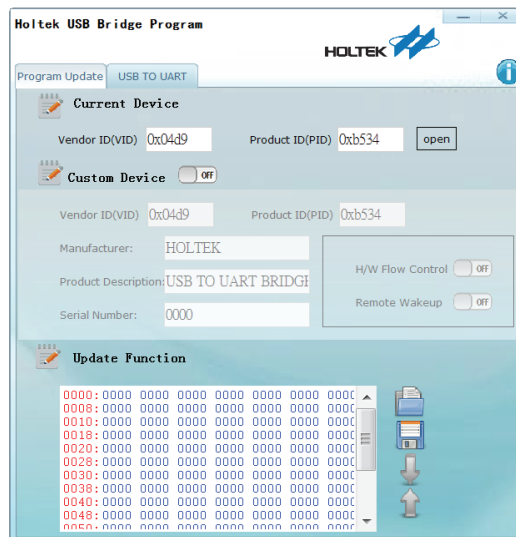

Program Update Block

On the program update block page, first open the Holtek VID/PID Bridge IC. If the USB has been plugged into the host PC, a new window will pop up showing USB open success. The user can update the customer VID, PID, manufacturer name, product description, serial number and 256 bytes of user memory as well as set the UART bridge device hardware flow control and remote wake-up functions. A user memory area, where no special data has been stored, can be used by the user for self-definition.

The following table shows the configuration descriptor length.

Parameter	Length
USB Vendor ID(VID)	1 Word (hex)
USB Product ID(PID)	1 Word (hex)
Manufacturer Name	Max. support 16 characters
Product Description	Max. support 32 characters
Serial Number	Max. support 4 words

The main figure of the program update block is as follows:

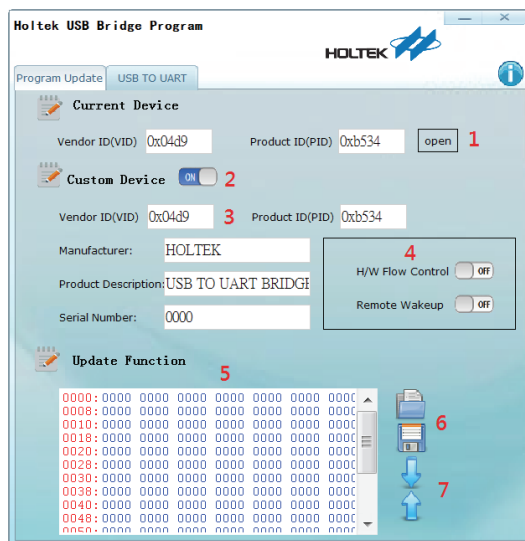

Configuration operating steps:

- Step1: Open the Holtek Bridge VID/PID device.
- Step2: Change custom device or go to USB to UART page.
- Step3: Input VID/PID and product strings (If the user needs to change custom device).
- Step4: Hardware flow control and remote wakeup setting.

- Step5: Import user memory (user optional).
- Step6: Save or open user memory data (user optional).
- Step7: Download or upload VID/PID/Product strings and the user memory data.

USB to UART Block

The USB to UART setting block is used to configure the baud rate, data, stop bits, parity, flow control and data transmit/receive demo. This page can also control the output RTS and DTR toggle pins, CTS, RI, DSR and DCD pins input status.

The figure for the USB to UART is as follows:



USB to UART Bridge operating steps:

- Step1: Select USB to UART page.
- Step2: Check that device is HT42B534-x.
- Step3: Select COM port number.
- Step4: Select baud rate.
- Step5: Select one or two stop bits.
- Step6: Select parity.
- Step7: Select flow control function.
- Step8: Open the selections.
- Step9: Input the data to be transmitted.
- Step10: Send data.
- Step11: Receive data.
- Step12: Toggle RTS/ DTR pins.
- Step13: Input CTS/RI/DSR/DCD pins status.

Application Circuits

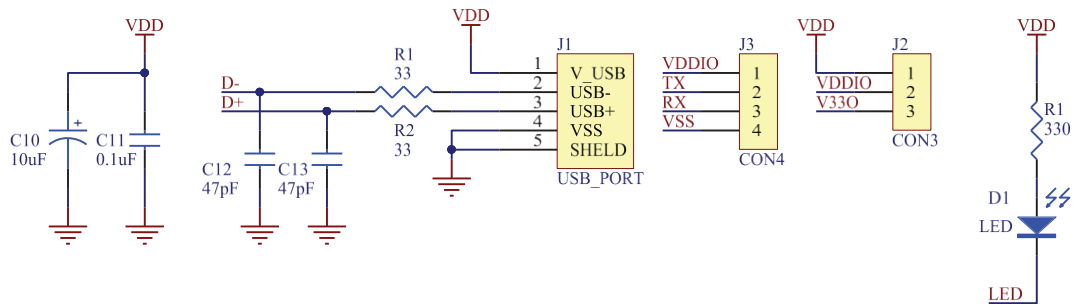
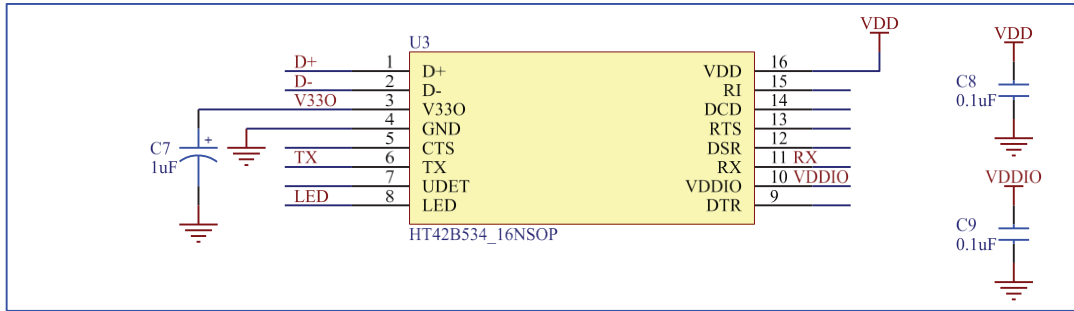
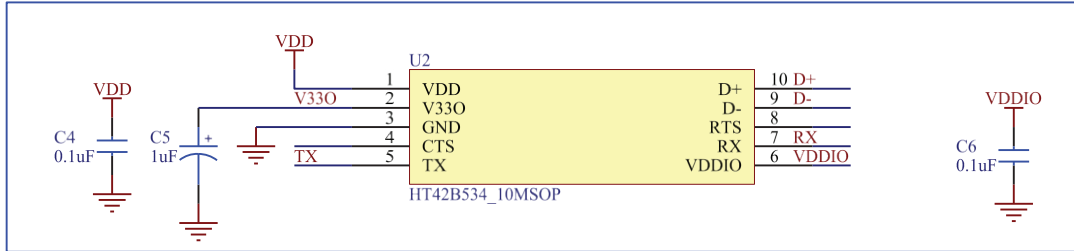
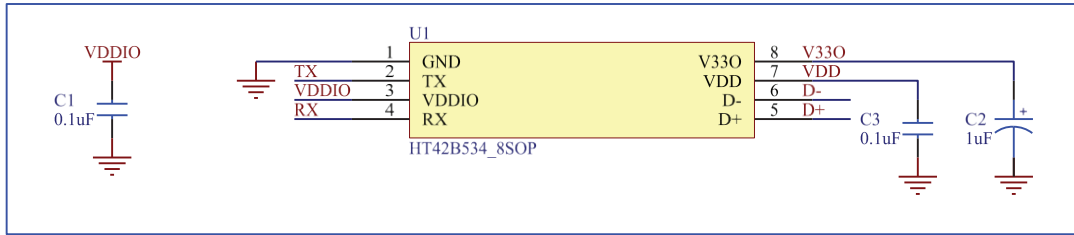

Dual Power Product Application Circuits

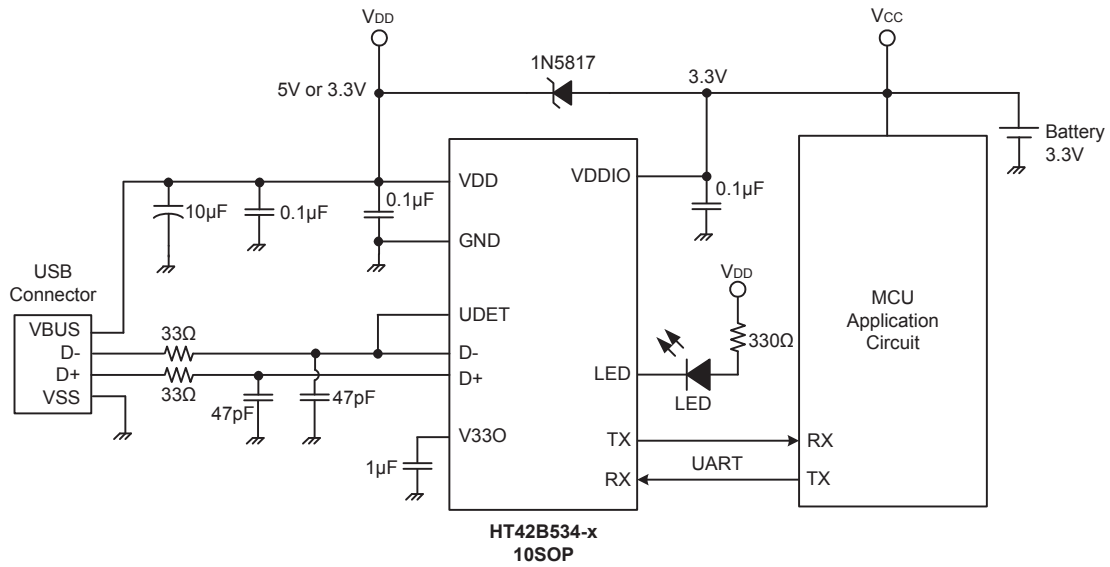

- Note: 1. Design note: 10-SOP package only for two power application, the VCC power must be below VDD power. (The VCC power can be from the Li-battery).
2. The UDET pin can be used to detect the USB plug-in for transfer data, detect the USB plug-out for entry energy saving mode.

Package Information

Note that the package information provided here is for consultation purposes only. As this information may be updated at regular intervals users are reminded to consult the [Holtek website](#) for the latest version of the [Package/ Carton Information](#).

Additional supplementary information with regard to packaging is listed below. Click on the relevant section to be transferred to the relevant website page.

- Package Information (include Outline Dimensions, Product Tape and Reel Specifications)
- The Operation Instruction of Packing Materials
- Carton information

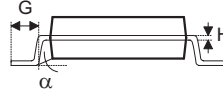
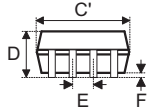
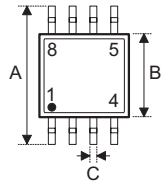
8-pin SOP (150mil) Outline Dimensions

Symbol	Dimensions in inch		
	Min.	Nom.	Max.
A	—	0.236 BSC	—
B	—	0.154 BSC	—
C	0.012	—	0.020
C'	—	0.193 BSC	—
D	—	—	0.069
E	—	0.050 BSC	—
F	0.004	—	0.010
G	0.016	—	0.050
H	0.004	—	0.010
α	0°	—	8°

Symbol	Dimensions in mm		
	Min.	Nom.	Max.
A	—	6.00 BSC	—
B	—	3.90 BSC	—
C	0.31	—	0.51
C'	—	4.90 BSC	—
D	—	—	1.75
E	—	1.27 BSC	—
F	0.10	—	0.25
G	0.40	—	1.27
H	0.10	—	0.25
α	0°	—	8°

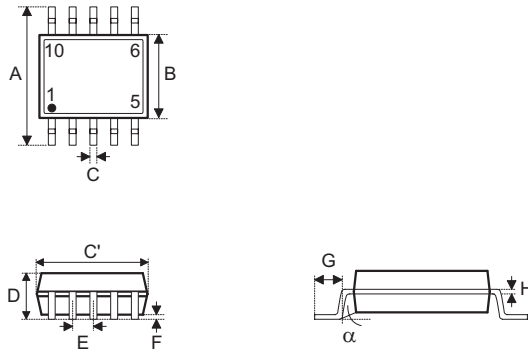
10-pin SOP (150mil) Outline Dimensions

Symbol	Dimensions in inch		
	Min.	Nom.	Max.
A	—	0.236 BSC	—
B	—	0.154 BSC	—
C	0.012	—	0.018
C'	—	0.193 BSC	—
D	—	—	0.069
E	—	0.039 BSC	—
F	0.004	—	0.010
G	0.016	—	0.050
H	0.004	—	0.010
α	0°	—	8°

Symbol	Dimensions in mm		
	Min.	Nom.	Max.
A	—F	6.00 BSC	—
B	—	3.90 BSC	—
C	0.30	—	0.45
C'	—	4.90 BSC	—
D	—	—	1.75
E	—	1.00 BSC	—
F	0.10	—	0.25
G	0.40	—	1.27
H	0.10	—	0.25
α	0°	—	8°

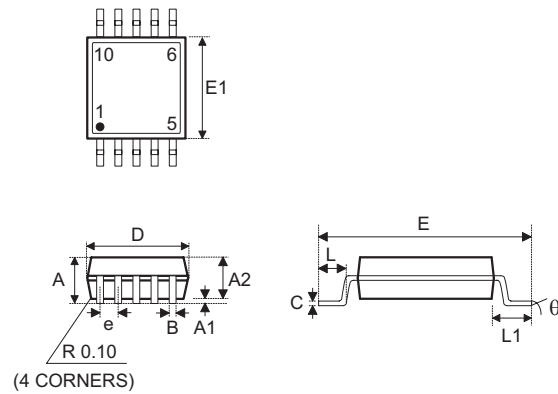
10-pin MSOP Outline Dimensions

Symbol	Dimensions in inch		
	Min.	Nom.	Max.
A	—	—	0.043
A1	0.000	—	0.006
A2	0.030	0.033	0.037
B	0.007	—	0.013
C	0.003	—	0.009
D	—	0.118 BSC	—
E	—	0.193 BSC	—
E1	—	0.118 BSC	—
e	—	0.020 BSC	—
L	0.016	0.024	0.031
L1	—	0.037 BSC	—
y	—	0.004	—
θ	0°	—	8°

Symbol	Dimensions in mm		
	Min.	Nom.	Max.
A	—	—	1.10
A1	0.00	—	0.15
A2	0.75	0.85	0.95
B	0.17	—	0.33
C	0.08	—	0.23
D	—	3.00 BSC	—
E	—	4.90 BSC	—
E1	—	3.00 BSC	—
e	—	0.50 BSC	—
L	0.40	0.60	0.80
L1	—	0.95 BSC	—
y	—	0.10	—
θ	0°	—	8°

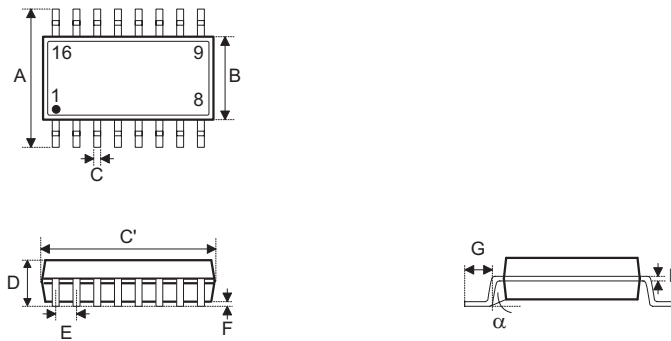
16-pin NSOP (150mil) Outline Dimensions

Symbol	Dimensions in inch		
	Min.	Nom.	Max.
A	—	0.236 BSC	—
B	—	0.154 BSC	—
C	0.012	—	0.020
C'	—	0.390 BSC	—
D	—	—	0.069
E	—	0.050 BSC	—
F	0.004	—	0.010
G	0.016	—	0.050
H	0.004	—	0.010
α	0°	—	8°

Symbol	Dimensions in mm		
	Min.	Nom.	Max.
A	—	6.0 BSC	—
B	—	3.9 BSC	—
C	0.31	—	0.51
C'	—	9.9 BSC	—
D	—	—	1.75
E	—	1.27 BSC	—
F	0.10	—	0.25
G	0.40	—	1.27
H	0.10	—	0.25
α	0°	—	8°

Copyright© 2016 by HOLTEK SEMICONDUCTOR INC.

The information appearing in this Data Sheet is believed to be accurate at the time of publication. However, Holtek assumes no responsibility arising from the use of the specifications described. The applications mentioned herein are used solely for the purpose of illustration and Holtek makes no warranty or representation that such applications will be suitable without further modification, nor recommends the use of its products for application that may present a risk to human life due to malfunction or otherwise. Holtek's products are not authorized for use as critical components in life support devices or systems. Holtek reserves the right to alter its products without prior notification. For the most up-to-date information, please visit our web site at <http://www.holtek.com/en/>.