

Features

- Complete Data Transmission on Power Line functions
- High Maximum Input Voltage: 42V
- Integrated Low Dropout Voltage Regulator
- Integrated Voltage Detector for Power Supply Monitoring
- Integrated Comparator
- Open drain NMOS driver for flexible interfacing
- Power and Reset Protection Features
- 8-pin SOP package type
- Minimal external component requirements

General Description

In systems where a master controller controls a number of individual interconnected subsystems such as found in smoke detector systems, water metering systems, solar energy system etc., the cost of the

lengthy interconnecting cabling can be a major factor. By sending data along the power supply lines, the interconnecting cables can be reduced to a simple two line type, thus greatly reducing both cable and installation costs.

With the addition of a few external components, this power line data transceiver devices contain all the internal components required to provide users with a system for power line data transmission and reception. Data is modulated onto the power line by the simple reduction of the power line voltage for a specific period of time. Power supply voltage changes can be initiated by the master controller for data reception or initiated by the HT45B000x devices for data transmission. An internal voltage regulator within the devices ensures that a constant voltage power supply is provided to the interconnected subsystem units while an internal voltage detector monitors the power line voltage level. An internal comparator is used to translate the differential signal into a logic signal for the MCU.

Selection Guide

Part No.	LDO Voltage	Detect Voltage	Package
HT45B0003	3.3V	5.25V	8SOP
HT45B0005	5.0V	5.25V	8SOP

Block Diagram

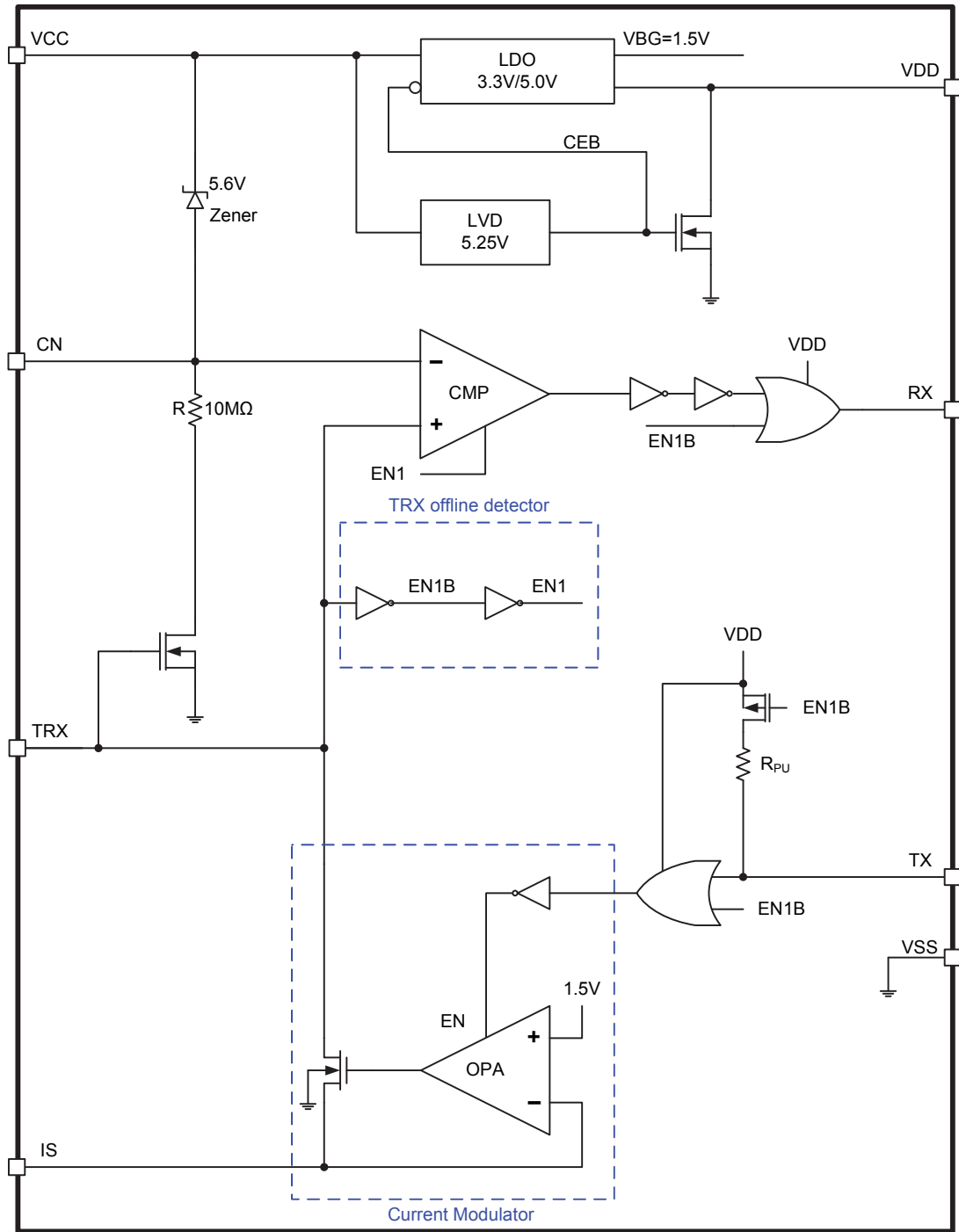

Pin Assignment

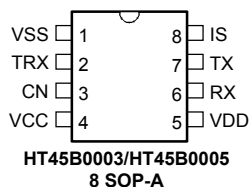

Pin Description

Pin Name	I/O	Description
VCC	—	Input voltage
CN	I	Comparator Negative Input
TRX	B	Transceiver signal detect/modulate
VSS	—	Ground pin – VSS
IS	O	Source terminal of constant current NMOS driver
TX	O	Input pin for constant current modulate
RX	O	Comparator output, transmitter signal detect output
VDD	—	LDO output voltage

Absolute Maximum Ratings

Supply Voltage	V_{SS} -0.3~50V	I_{OL} Total	80mA
Operating Temperature	-40°C~85°C	I_{OH} Total	-80mA
Storage Temperature	-50°C~125°C	Total Power Dissipation	500mW

Note: These are stress ratings only. Stresses exceeding the range specified under “Absolute Maximum Ratings” may cause substantial damage to the device. Functional operation of this device at other conditions beyond those listed in the specification is not implied and prolonged exposure to extreme conditions may affect device reliability.

D.C. Characteristics

$T_a=25^\circ\text{C}$

Symbol	Parameter	Test Conditions		Min.	Typ.	Max.	Unit
		V_{DD}	Conditions				
V_{CC}	Operating Voltage	—	—	7	—	42	V
I_{CC}	Operating Current	—	$V_{CC}=42\text{V}$, V_{DD} No Load,	—	20	40	μA
I_{OFF}	Offline Current	—	$V_{CC}=42\text{V}$, V_{DD} No Load, $TRX=0\text{V}$	—	10	20	μA
V_{OFF}	TRX Offline Voltage	—	—	—	—	0.5	V
V_{ON}	TRX Online Voltage	—	—	4	—	—	V
V_T	Threshold Voltage	—	—	—	$V_{MARK}-5.6$	—	V
I_{MC}	Modulate Current	—	$R_S=100\Omega$	—	15	—	mA
		—	$R_S=47\Omega$	—	32	—	mA
V_{IL}	Input low voltage for TX pin	5V	—	0	—	1.5	V
		3.3V	—	0	—	$0.2V_{DD}$	V
V_{IH}	Input high voltage for TX pin	5V	—	3.5	—	5	V
		3.3V	—	$0.8V_{DD}$	—	V_{DD}	V

Symbol	Parameter	Test Conditions		Min.	Typ.	Max.	Unit
		V _{DD}	Conditions				
I _{OL}	Sink current for RX pin	3.3V	V _{OL} =0.1V _{DD}	4	8	—	mA
		5V	V _{OL} =0.1V _{DD}	10	20	—	mA
I _{OH}	Source current for RX pin	3.3V	V _{OH} =0.9V _{DD}	-2	-4	—	mA
		5V	V _{OH} =0.9V _{DD}	-5	-10	—	mA
R _{PH}	Pull-high Resistance for TX	—	—	-30%	50	30%	kΩ

LDO Characteristics

Ta=25°C

Symbol	Parameter	Test Conditions		Min.	Typ.	Max.	Unit
		V _{DD}	Conditions				
V _{OUT}	Output Voltage	3.3V	V _{CC} =7V, I _{LOAD} =10mA	3.2	3.3	3.4	V
		5V		4.85	5	5.15	V
I _{OUT}	Output Current	—	V _{CC} =10V, ΔV _{OUT} =-3%	60	—	—	mA
			V _{CC} =7V, ΔV _{OUT} =-3%	30	—	—	mA
ΔV _{LINE}	Line Regulation	—	7V ≤ V _{IN} ≤ 42V, I _{LOAD} =1mA	—	—	0.2	%/V
TC	Temperature Coefficient	3.3V	Ta=-40°C ~ 85°C, V _{CC} =7V, I _{LOAD} =10mA	—	±0.5	±1	mV/°C
		5V	Ta=-40°C ~ 85°C, V _{CC} =7V, I _{LOAD} =10mA	—	±0.75	±1.5	mV/°C
ΔV _{OUT_RIPPLE}	Output Voltage Ripple	—	V _{CC} =7V, I _{LOAD} =10mA	—	—	40	mV
t _{START}	LDO Startup Time	3.3V	V _{CC} =7V, I _{LOAD} =1mA, V _{OUT} =3.3V ± 3%	—	—	10	ms
		5V	V _{CC} =7V, I _{LOAD} =1mA, V _{OUT} =5V ± 3%	—	—	10	ms
I _{OL}	Sink current for VDD	—	V _{CC} =5V, V _{OL} =0.5V	0.8	—	—	mA

LVD Characteristics

Ta=25°C

Symbol	Parameter	Test Conditions		Min.	Typ.	Max.	Unit
		V _{DD}	Conditions				
V _{LVD}	Low Voltage Detection Voltage	—	—	5.0	5.25	5.5	V
TC	Temperature Coefficient (ΔV _{LVD} /ΔTa)	—	Ta=-40°C ~ 85°C	—	±0.9	—	mV/°C
V _{DET}	Power-up Detection Voltage (VCC Positive-going Threshold Voltage)	—	—	6.2	6.5	6.8	V

Comparator Characteristics

Ta=25°C

Symbol	Parameter	Test Conditions		Min.	Typ.	Max.	Unit
		V _{DD}	Conditions				
A _{OL}	Open loop gain	—	—	60	80	—	dB
V _{HYS}	Hysteresis	—	—	—	0.15	—	V
t _{RP}	Response time	—	—	—	—	5	μs

Constant Current Modulator Characteristics

Ta=25°C

Symbol	Parameter	Test Conditions		Min.	Typ.	Max.	Unit
		V _{DD}	Conditions				
t _{RP}	Response Time	—	No Load	—	—	5	μA

Function Description

These devices provide a way to transmit and receive data on the common power lines of an interconnected array of microcontroller based subsystems. By having one of these devices inside each subsystem, the shared power and data cabling can be reduced to a simple two line type, offering major installation cost reductions.

Shared Power Line

All microcontroller based subsystems are connected together via the same two line power connection. The ground line is hardwired to each subsystem while the positive power line is connected to the VCC pin on each of the HT45B000x devices. An internal Low Dropout Voltage Regulator within the HT45B000x devices converts this input power supply voltage to a fixed voltage level which is supplied to the subsystem microcontroller and other circuit components. In this way when the power line voltage is changed due to the transmission or reception of data the subsystem circuits still continue to receive a regulated power supply.

Data Transmission (From Master Controller to Slave Device)

Refer to the application circuit when reading the following description. The master controller transmits the data by modulate the positive power line (L+) voltage. Using this method should be pay attention to the noise tolerance of the devices operating voltage and the TRX pin receiving data. As the devices include a voltage regulator which is used as the power supply to the subsystem units, then the subsystem power supply voltage will not be affected as long as the regulator minimum dropout voltage is maintained. Then a voltage modulation signal will be detected in the TRX pin to make the TRX pin voltage drop lower than the threshold voltage (V_T). However a reduction in the power supply will be detected by the CMP internal comparator. The output of this comparator is connected to pin RX can be connected to a microcontroller input for use as a data signal.

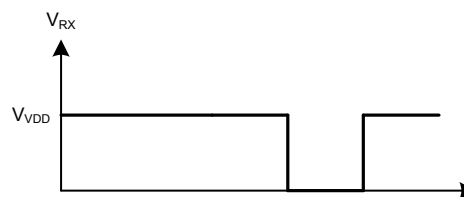
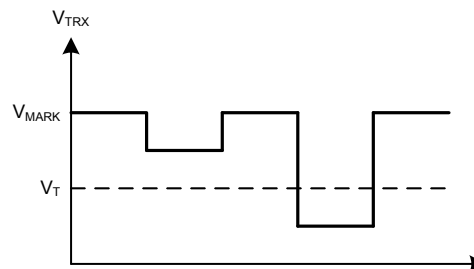

Power Line Data Reception

Data Reception (From Slave Device to Master Controller)

Refer to the application circuit when reading the following description. The HT45B000X slave devices can transmit data to the master controller by modulating the current on the power supply line. The slave devices pull the TX pin voltage to a low level to enable the internal current modulator. The modeulator will provide a constant current load by the transistor connected to the internal modulator OPA output NMOS terminal. The constant current load is supplied by the power line through the TRX pin, and can be adjusted by the R_S resistor connected on the IS pin. Therefore, the current modulation signals can be generated on the TRX pin by control the TX pin voltage level. The current modulation signal can return to the master controller through the power supply line.

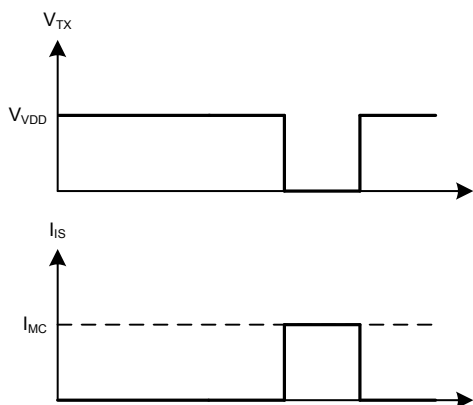

Current Modulator

The devices can modulate power line current by adding additional constant current source which control by TX pin. When TX pin connect to low level will enable this current modulation function. The modulation current can be calculated by the following formula:

$$I_{IS} = 1.5V/R_S$$

Application Considerations

It is envisaged that the devices will be used together with microcontroller based subsystems which will be required to provide two I/O pins for data transmission and reception. The MCU pin connected to the TX pin must be setup as an output while the MCU pin connected to the RX pin must be setup as an input.

Offline Detection

Refer to the application circuit when reading the following description. When the master controller power line is offline, the TRX pin will be pulled low via $2M\Omega$ resistor which will enable offline detection function. In this case, the CMP and OPA functions will be forced to disable to reduce power consumption. The offline mechanism will be dispelled until the power line restarts to be powered on to pull high the TRX pin voltage.

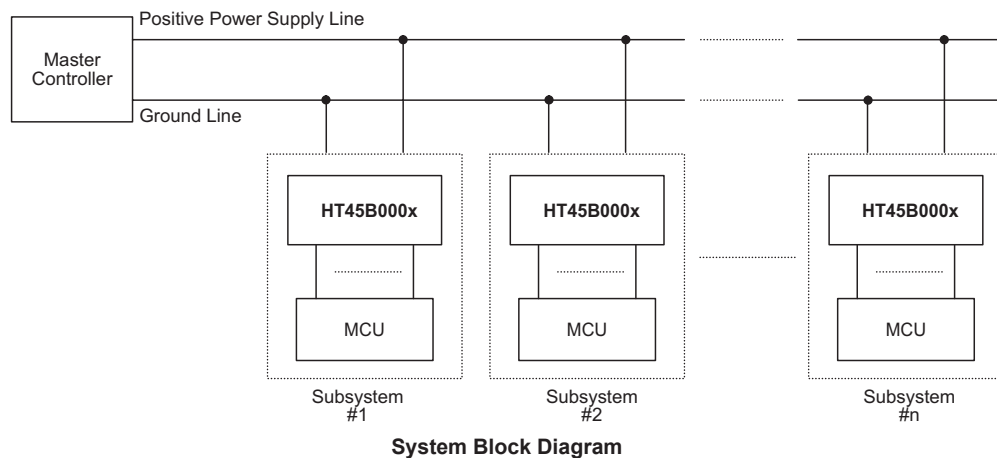

Application Circuits

The following application circuit shows the device used in conjunction with a microcontroller.

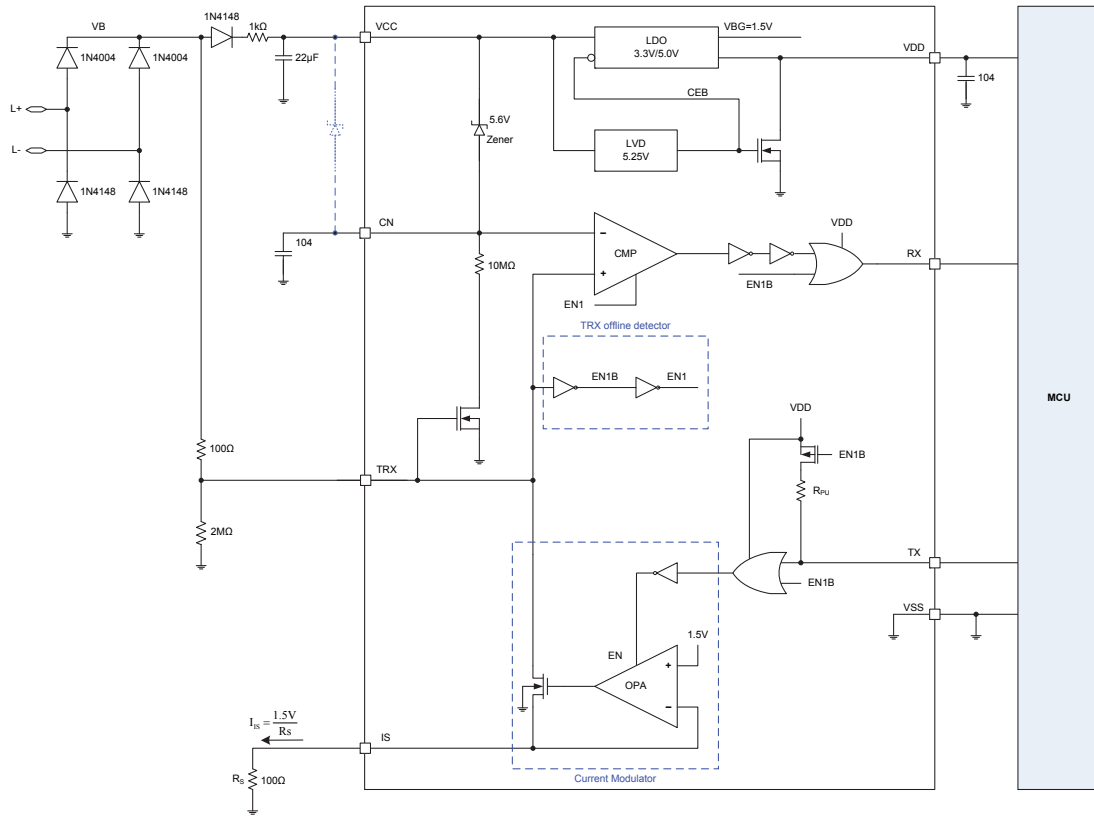

Package Information

Note that the package information provided here is for consultation purposes only. As this information may be updated at regular intervals users are reminded to consult the [Holtek website](#) for the latest version of the [Package/Carton Information](#).

Additional supplementary information with regard to packaging is listed below. Click on the relevant section to be transferred to the relevant website page.

- [Further Package Information \(include Outline Dimensions, Product Tape and Reel Specifications\)](#)
- [Packing Materials Information](#)
- [Carton information](#)

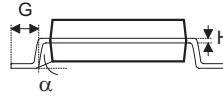
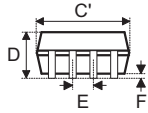
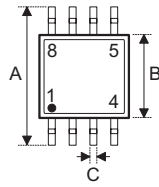
8-pin SOP (150mil) Outline Dimensions

Symbol	Dimensions in inch		
	Min.	Nom.	Max.
A	—	0.236 BSC	—
B	—	0.154 BSC	—
C	0.012	—	0.020
C'	—	0.193 BSC	—
D	—	—	0.069
E	—	0.050 BSC	—
F	0.004	—	0.010
G	0.016	—	0.050
H	0.004	—	0.010
α	0°	—	8°

Symbol	Dimensions in mm		
	Min.	Nom.	Max.
A	—	6.00 BSC	—
B	—	3.90 BSC	—
C	0.31	—	0.51
C'	—	4.90 BSC	—
D	—	—	1.75
E	—	1.27 BSC	—
F	0.10	—	0.25
G	0.40	—	1.27
H	0.10	—	0.25
α	0°	—	8°

Copyright© 2016 by HOLTEK SEMICONDUCTOR INC.

The information appearing in this Data Sheet is believed to be accurate at the time of publication. However, Holtek assumes no responsibility arising from the use of the specifications described. The applications mentioned herein are used solely for the purpose of illustration and Holtek makes no warranty or representation that such applications will be suitable without further modification, nor recommends the use of its products for application that may present a risk to human life due to malfunction or otherwise. Holtek's products are not authorized for use as critical components in life support devices or systems. Holtek reserves the right to alter its products without prior notification. For the most up-to-date information, please visit our web site at <http://www.holtek.com.tw/en/home>.