



Cord-free Vacuum Cleaner ASSP Flash MCU

HT45F0084

Revision: V1.00 Date: March 17, 2017

www.holtek.com

Table of Contents

Features	6
CPU Features	6
Peripheral Features.....	6
General Description	7
Block Diagram	7
Pin Assignment	8
Pin Descriptions	9
Absolute Maximum Ratings	11
D.C. Characteristics	11
A.C. Characteristics	13
LVD&LVR Electrical Characteristics	14
ADC Electrical Characteristics	14
Over/Under Voltage Circuit Electrical Characteristics	15
Over Current Circuit Electrical Characteristics	16
Power on Reset Electrical Characteristics	16
System Architecture	17
Clocking and Pipelining.....	17
Program Counter.....	18
Stack	19
Arithmetic and Logic Unit – ALU	19
Flash Program Memory	20
Structure.....	20
Special Vectors	20
Look-up Table.....	21
Table Program Example	21
In Circuit Programming	22
On-Chip Debug Support – OCDS	23
RAM Data Memory	24
Structure.....	24
Special Function Register Description	26
Indirect Addressing Registers – IAR0, IAR1	26
Memory Pointers – MP0, MP1	26
Bank Pointer – BP.....	27
Accumulator – ACC.....	27
Program Counter Low Register – PCL.....	27
Look-up Table Registers – TBLP, TBHP, TBLH.....	27
Status Register – STATUS.....	28
EEPROM Data Memory	30
EEPROM Data Memory Structure	30

EEPROM Registers	30
Reading Data from the EEPROM	32
Writing Data to the EEPROM.....	32
Write Protection.....	32
EEPROM Interrupt	32
Programming Considerations.....	33
Oscillator	34
Oscillator Overview	34
System Clock Configurations	34
Internal RC Oscillator – HIRC	35
Internal 32kHz Oscillator – LIRC.....	35
Operating Modes and System Clocks	35
System Clocks	35
System Operation Modes.....	36
Control Register	37
Operating Mode Switching	40
Standby Current Considerations	43
Wake-up	44
Watchdog Timer.....	45
Watchdog Timer Clock Source.....	45
Watchdog Timer Control Register	45
Watchdog Timer Operation	46
Reset and Initialisation.....	47
Reset Functions	47
Reset Initial Conditions	50
Input/Output Ports	53
Pull-high and Pull-low Resistors.....	53
Port A and Port B Wake-up	55
I/O Port Control Registers	55
Pin-shared Functions	56
I/O Pin Structures.....	58
Programming Considerations.....	59
Timer Modules – TM	60
Introduction	60
TM Operation	60
TM Clock Source.....	61
TM Interrupts.....	61
TM External Pins.....	61
Programming Considerations.....	62
Standard Type TM – STM	63
Standard TM Operation.....	63
Standard Type TM Register Description	64
Standard Type TM Operating Modes	68

Periodic Type TM – PTM	77
Periodic TM Operation	77
Periodic Type TM Register Description	77
Periodic Type TM Operating Modes	82
Compact Type TM – CTM	91
Compact TM Operation	91
Compact Type TM Register Description.....	92
Compact Type TM Operating Modes	96
Analog to Digital Converter	102
A/D Overview	102
A/D Converter Register Description	102
A/D Operation	105
A/D Input Pins	106
Summary of A/D Conversion Steps.....	107
Programming Considerations.....	108
A/D Transfer Function	108
A/D Programming Examples	109
Complementary PWM Output	111
Over Current Protection	113
OCP0/OCP1 Function.....	113
OCP0 and OCP1 Control Registers.....	114
Over Voltage Protection and Under Voltage Protection	120
OVP Control Registers	120
Auto-adjust PWM	123
Auto-adjust PWM Control Registers	124
Integrated Divider Resistor and Internal Switch	127
Internal Switch Set Register – SWS.....	129
Interrupts	130
Interrupt Registers.....	130
Interrupt Operation	135
External Interrupt.....	137
UVP Interrupt	137
OVP Interrupt	137
OCP Interrupt.....	137
Multi-function Interrupt	138
A/D Converter Interrupt.....	138
Time Base Interrupts	138
EEPROM Interrupt.....	139
LVD Interrupt.....	140
TM Interrupts.....	140
Interrupt Wake-up Function.....	140
Programming Considerations.....	141

Low Voltage Detector – LVD	142
LVD Register	142
LVD Operation.....	143
Instruction Set.....	144
Introduction	144
Instruction Timing	144
Moving and Transferring Data.....	144
Arithmetic Operations.....	144
Logical and Rotate Operations.....	145
Branches and Control Transfer	145
Bit Operations	145
Table Read Operations	145
Other Operations.....	145
Instruction Set Summary	146
Instruction Definition.....	148
Package Information	157
16-pin NSOP (150mil) Outline Dimensions.....	158
20-pin SSOP (150mil) Outline Dimensions	159

Features

CPU Features

- Operating Voltage
 - ♦ $f_{SYS}=15\text{MHz}$: 4.5V~5.5V
 - ♦ $f_{SYS}=7.5\text{MHz}$: 2.5V~5.5V
- Up to 0.27 μs instruction cycle with 15MHz system clock at $V_{DD}=5\text{V}$
- Power down and wake-up functions to reduce power consumption
- Oscillators
 - ♦ Internal 30MHz RC – HIRC
 - ♦ Internal 32kHz – LIRC
- Fully intergrated internal 30MHz oscillator requires no external components
- Multi-mode operation: NORMAL, SLOW, IDLE and SLEEP
- All instructions executed in one or two instruction cycles
- Table read instructions
- 61 powerful instructions
- 4-level subroutine nesting
- Bit manipulation instruction

Peripheral Features

- Flash Program Memory: 2K \times 16
- RAM Data Memory: 128 \times 8
- True EEPROM Memory: 64 \times 8
- Watchdog Timer function
- Up to 18 bidirectional I/O lines
- Two pin-shared external interrupts
- Multiple Timer Module for time measure, input capture, compare match output, PWM output function or single pulse output function
- Over current protection (OCP) with interrupt
- Over/Under voltage protection (OUVP) with interrupt
- Auto-adjust PWM Duty (PTM CCRA) together with OUVP function
- Dual Time-Base functions for generation of fixed time interrupt signals
- 8-channel 12-bit resolution A/D converter
- Low voltage reset function (enable@2.55V)
- Low voltage detect function
- Package: 16-pin NSOP and 20-pin SSOP

General Description

The device is a Flash Memory type 8-bit high performance RISC architecture microcontroller. Offering users the convenience of Flash Memory multi-programming features, this device also includes a wide range of functions and features. Other memory includes an area of RAM Data Memory as well as an area of true EEPROM memory for storage of non-volatile data such as serial numbers, calibration data etc.

Analog features include a multi-channel 12-bit A/D converter, an over current protection function, an over voltage protection function, an under voltage protection function, and an auto-adjust PWM Duty function. Multiple and extremely flexible Timer Modules provide timing, pulse generation and PWM generation functions. Protective features such as an internal Watchdog Timer, Low Voltage Reset and Low Voltage Detector coupled with excellent noise immunity and ESD protection ensure that reliable operation is maintained in hostile electrical environments.

A full choice of HIRC and LIRC oscillator functions are provided including a fully integrated system oscillator which requires no external components for its implementation. The ability to operate and switch dynamically between a range of operating modes using different clock sources gives users the ability to optimise microcontroller operation and minimize power consumption.

The inclusion of flexible I/O programming features, Time-Base functions along with many other features ensure that the device will find excellent use in applications such as electronic metering, environmental monitoring, handheld instruments, household appliances, electronically controlled tools, motor driving in addition to many others.

Block Diagram

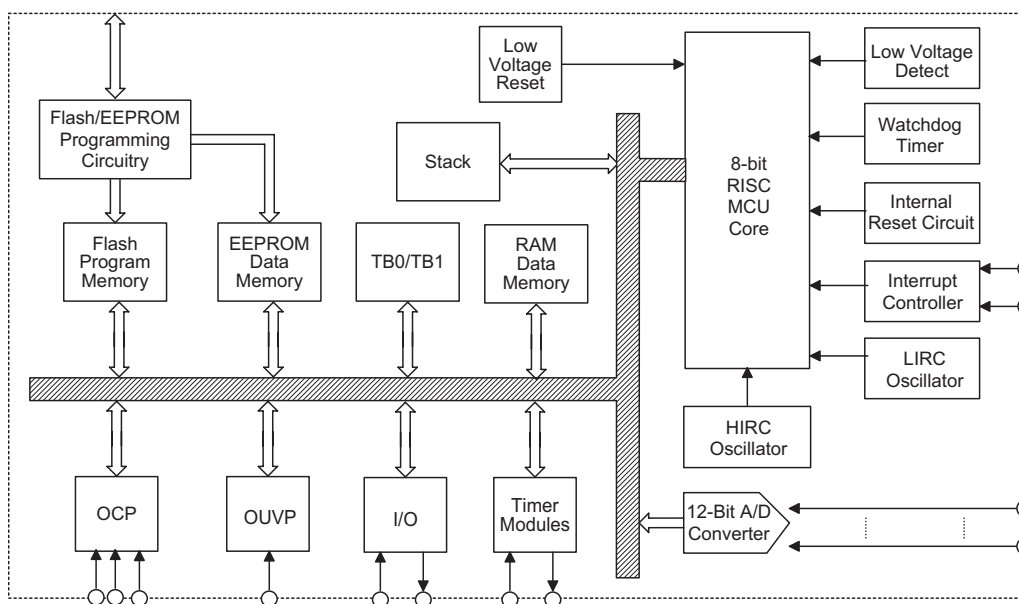

Pin Assignment

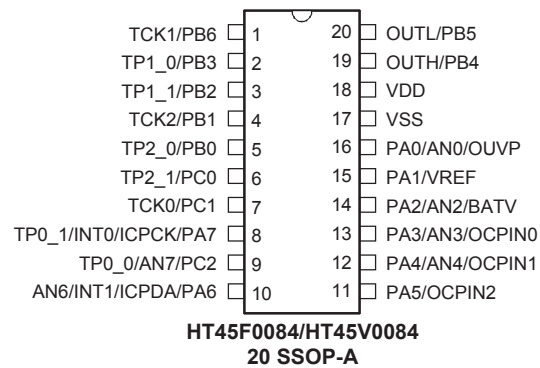
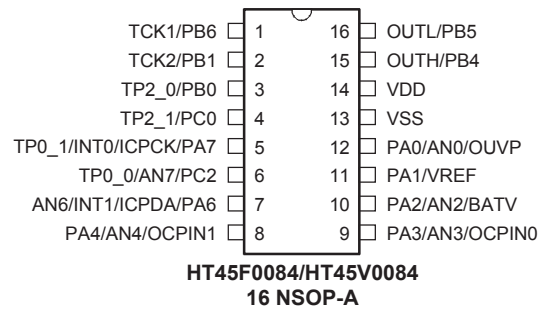

- Note: 1. Pin shared function is controlled by registers.
 2. Both real IC and OCDS EV IC share the same package. The OCDS EV IC is HT45V4Y.
 The OCDSCK and OCSDA pins are only for the OCDS EV IC.

Pin Descriptions

With the exception of the power pins and some relevant transformer control pins, all pins on these devices can be referenced by their Port name, e.g. PA0, PA1 etc, which refer to the digital I/O function of the pins. However these Port pins are also shared with other function such as the Analog to Digital Converter, Timer Module pins etc. The function of each pin is listed in the following table, however the details behind how each pin is configured is contained in other sections of the datasheet.

Pin Name	Function	OPT	I/T	O/T	Description
PA0/AN0/OUVP	PA0	PAPU PAWU PAPS0	ST	CMOS	General purpose I/O. Register enabled pull-high and falling edge wake-up.
	AN0	PAPS0	AN	—	ADC input
	OUVP	PAPS0	AN	—	Over/under voltage protection input
PA1/VREF	PA1	PAPU PAWU PAPS0	ST	CMOS	General purpose I/O. Register enabled pull-high and falling edge wake-up.
	VREF	ADCR1 PAPS0	AN	—	A/DC, OCP0, OCP1 and OUVP reference voltage input
PA2/AN2/BATV	PA2	PAPU PAWU PAPS0	ST	CMOS	General purpose I/O. Register enabled pull-high and falling edge wake-up.
	AN2	PAPS0	AN	—	ADC input
	BATV	PAPS0	AN	—	Battery voltage input
PA3/AN3/OCPIN0	PA3	PAPU PAWU PAPS0	ST	CMOS	General purpose I/O. Register enabled pull-high and falling edge wake-up.
	AN3	PAPS0	AN	—	ADC input
	OCPIN0	PAPS0	AN	—	Over current protection 0 input
PA4/AN4/OCPIN1	PA4	PAPU PAWU PAPS1	ST	CMOS	General purpose I/O. Register enabled pull-high and falling edge wake-up.
	AN4	PAPS1	AN	—	ADC input
	OCPIN1	PAPS1	AN	—	Over current protection 1 input
PA5/OCPIN2	PA5	PAPU PAWU PAPS1	ST	CMOS	General purpose I/O. Register enabled pull-high and falling edge wake-up.
	OCPIN2	PAPS1	AN	—	Over current protection 2 input
PA6/INT1/AN6/ ICPDA/OCSDA	PA6	PAPU PAWU PAPS1	ST	CMOS	General purpose I/O. Register enabled pull-high and falling edge wake-up.
	INT1	PAPS1	ST	—	External interrupt 1
	AN6	PAPS1	AN	—	ADC input
	ICPDA	—	ST	CMOS	In-circuit programming clock pin
	OCSDA	—	ST	CMOS	On-chip debug support data/address pin. OCSDA pin is available only for OCDS EV.

Pin Name	Function	OPT	I/T	O/T	Description
PA7/TP0_1/INT0/ ICPCK/OCDSCK	PA7	PAPU PAWU PAPS1	ST	CMOS	General purpose I/O. Register enabled pull-high and falling edge wake-up.
	TP0_1	PAPS1	ST	CMOS	TM0 I/O
	INT0	PAPS1	ST	—	External interrupt 0
	ICPCK	—	ST	—	In-circuit programming clock pin
	OCDSCK	—	ST	—	On-chip debug support clock pin OCDSCK pin is available only for OCDS EV.
PB0/TP2_0	PB0	PBPS	ST	CMOS	General purpose I/O. Register enabled pull-high
	TP2_0	PBPS	ST	CMOS	TM2 I/O
PB1/TCK2	PB1	PBPL PBWU	ST	CMOS	General purpose I/O. Register enabled pull-low and raising edge wake-up.
	TCK2	—	ST	—	TM2 input
PB2/TP1_1	PB2	PBPS PBPU	ST	CMOS	General purpose I/O. Register enabled pull-high.
	TP1_1	PBPS	ST	CMOS	TM1 I/O
PB3/TP1_0	PB3	PBPS PBPU PBWU	ST	CMOS	General purpose I/O. Register enabled pull-low and raising edge wake-up.
	TP1_0	PBPS	ST	CMOS	TM1 I/O
PB4/OUTH	PB4	PBPS	ST	CMOS	General purpose I/O. If configured as input, that pull-high is always enabled.
	OUTH	PBPS	—	CMOS	Complementary PWM output
PB5/OUTL	PB5	PBPS	ST	CMOS	General purpose I/O. If configured as input, that pull-low is always enabled.
	OUTL	PBPS	—	CMOS	Complementary PWM output
PB6/TCK1	PB6	—	ST	CMOS	General purpose I/O. If configured as input, that pull-low is always enabled.
	TCK1	—	ST	—	TM1 input
PC0/TP2_1	PC0	PCPS PCPU	ST	CMOS	General purpose I/O. Register enabled pull-high.
	TP2_1	PCPS	ST	CMOS	TM2 I/O
PC1/TCK0	PC1	PCPU	ST	CMOS	General purpose I/O. Register enabled pull-high.
	TCK0	—	ST	—	TM0 input
PC2/TP0_0/AN7	PC2	PCPS PCPU	ST	CMOS	General purpose I/O. Register enabled pull-high.
	TP0_0	PCPS	ST	CMOS	TM0 I/O
	AN7	PCPS	AN	—	ADC input
VDD	VDD	—	PWR	—	Digital positive power supply
VSS	VSS	—	PWR	—	Digital negative power supply

Legend: I/T: Input type; O/T: Output type
 OPT: Optional by register option
 PWR: Power; ST: Schmitt Trigger input
 CMOS: CMOS output; AN: Analog input pin

Absolute Maximum Ratings

Supply Voltage	$V_{SS}-0.3V$ to $V_{SS}+6.0V$
Input Voltage	$V_{SS}-0.3V$ to $V_{DD}+0.3V$
Storage Temperature.....	$-50^{\circ}C$ to $125^{\circ}C$
Operating Temperature.....	$-40^{\circ}C$ to $85^{\circ}C$
I_{OH} Total	-80mA
I_{OL} Total	80mA
Total Power Dissipation	500mW

Note: These are stress ratings only. Stresses exceeding the range specified under "Absolute Maximum Ratings" may cause substantial damage to these devices. Functional operation of these devices at other conditions beyond those listed in the specification is not implied and prolonged exposure to extreme conditions may affect devices reliability.

D.C. Characteristics

$T_a=25^{\circ}C$

Symbol	Parameter	Test Conditions		Min.	Typ.	Max.	Unit
		V_{DD}	Conditions				
V_{DD}	Operating Voltage	—	$f_{SYS}=7.5MHz$	V_{LVR}	—	5.5	V
		—	$f_{SYS}=15MHz$	V_{LVR}	—	5.5	V
I_{DD1}	Operation Current, Normal Mode $f_H=30MHz$ (HIRC)	3V	No load, $f_{SYS}=f_H/2$, ADC off, WDT enable	—	3.3	5.0	mA
		5V	ADC off, WDT enable	—	7.5	11.5	mA
		3V	No load, $f_{SYS}=f_H/4$, ADC off, WDT enable	—	2.4	3.6	mA
		5V	ADC off, WDT enable	—	5.4	8.1	mA
		3V	No load, $f_{SYS}=f_H/8$, ADC off, WDT enable	—	2.0	3.0	mA
		5V	ADC off, WDT enable	—	4.2	6.3	mA
		3V	No load, $f_{SYS}=f_H/16$, ADC off, WDT enable	—	1.8	2.7	mA
		5V	ADC off, WDT enable	—	3.6	5.4	mA
		3V	No load, $f_{SYS}=f_H/32$, ADC off, WDT enable	—	1.6	2.4	mA
		5V	ADC off, WDT enable	—	3.2	4.8	mA
I_{DD2}	Operating Current, Slow Mode, $f_{SYS}=f_{SUB}=LIRC$	3V	No load, $f_{SYS}=LIRC$, ADC off, WDT enable	—	10	20	μA
		5V	ADC off, WDT enable	—	30	50	μA
I_{IDLE0}	IDLE0 Mode Standby Current (LIRC on)	3V	No load, ADC off, WDT enable, LVR disable	—	1.3	3	μA
		5V	WDT enable, LVR disable	—	2.2	5	μA
I_{IDLE10}	IDLE1 Mode Standby Current (HIRC on)	3V	No load, ADC off, WDT enable, LVR disable, $f_{SYS}=7.5MHz$ on	—	2.0	3.0	mA
		5V	LVR disable, $f_{SYS}=7.5MHz$ on	—	4.0	6.0	mA
I_{IDLE11}	IDLE1 Mode Standby Current (HIRC on)	3V	No load, ADC off, WDT enable, LVR disable, $f_{SYS}=15MHz$ on	—	2.0	3.0	mA
		5V	LVR disable, $f_{SYS}=15MHz$ on	—	4.0	6.0	mA
I_{SLEEP}	Operating Current, Sleep Mode, $f_{SYS}=f_{SUB}=LIRC$	3V	No load, $f_{SYS}=LIRC$, ADC off, WDT enable, LVR disable	—	1.3	3	μA
		5V	WDT enable, LVR disable	—	2.2	5	μA
V_{IL}	Input Low Voltage for I/O Ports or Input Pins	5V	—	0	—	1.5	V
		—	—	0	—	$0.2V_{DD}$	V
V_{IH}	Input High Voltage for I/O Ports or Input Pins	5V	—	3.5	—	5.0	V
		—	—	$0.8V_{DD}$	—	V_{DD}	V

Symbol	Parameter	Test Conditions		Min.	Typ.	Max.	Unit
		V _{DD}	Conditions				
I _{OL1}	I/O Port Sink Current (I/O except for PB4, PB5)	3V	V _{OL} =0.1V _{DD}	22.6	45.2	—	mA
		5V		56.5	113	—	mA
I _{OH1}	I/O Port, Source Current (I/O except for PB4, PB5)	3V	V _{OH} =0.9V _{DD}	5.12	10.24	—	mA
		5V		12.8	25.6	—	mA
I _{OL2}	I/O Port Sink Current (I/O: PB4, PB5)	3V	V _{OL} =0.2V _{DD}	24	60	—	mA
		5V		60	150	—	mA
I _{OH2}	I/O Port, Source Current (I/O: PB4, PB5)	3V	V _{OH} =0.8V _{DD}	-24	-60	—	mA
		5V		-60	-150	—	mA
R _{PH}	Pull-high Resistance for I/O Ports	3V	—	20	60	100	kΩ
		5V	—	10	30	50	kΩ
R _{PL1}	Pull-low Resistance for PB5, PB6 (Always Enable)	3V	—	20	60	100	kΩ
		5V	—	10	30	50	kΩ
R _{PL2}	Pull-low Resistance for PB1, PB3	3V	—	1.5	—	2.25	MΩ
		5V	—	1	—	1.5	MΩ
V _{REFR}	Integrated Pull-high Resistance for PA1/VREF	3V	—	0.7	1	1.2	kΩ
		5V	—	0.7	1	1.2	kΩ
BATV_R1+ BATV_R2	Integrated Resistance Sum for BATV	3V	—	20	40	60	kΩ
		5V	—	20	40	60	kΩ
BATV_R1: BATV_R2	Integrated Resistance Ratio for BATV	3V	—	-1%	1:1	+1%	—
		5V	—	-1%	1:1	+1%	—
OUVP_R1+ OUVP_R2+ OUVP_R3	Integrated Resistance Sum for OUVP	3V	—	1.5	3	4.5	kΩ
		5V	—	1.5	3	4.5	kΩ
(OUVP_R1+ OUVP_R2): OUVP_R3=2:1	Integrated Resistance Ratio for OUVP	3V	—	-1%	2:1	+1%	—
		5V	—	-1%	2:1	+1%	—

A.C. Characteristics

Ta=25°C

Symbol	Parameter	Test Conditions		Min.	Typ.	Max.	Unit
		V _{DD}	Conditions				
f _{CPU}	Operating Clock	V _{LVR} ~5.5V	—	DC	—	7.5	MHz
		V _{LVR} ~5.5V	—	DC	—	15.0	MHz
f _{SYS}	System Clock (HIRC)	V _{LVR} ~5.5V	—	—	—	7.5	MHz
		V _{LVR} ~5.5V	—	—	—	15.0	MHz
f _{HIRC}	HIRC Frequency (Note)	5V	Ta=25°C	-2%	30	2%	MHz
		5V	Ta=-40°C ~ 85°C	-7%	30	7%	MHz
		4.5V~5.5V	Ta=-40°C ~ 85°C	-10%	30	10%	MHz
		3V~5.5V	Ta=-40°C ~ 85°C	-15%	30	15%	MHz
		V _{LVR} ~5.5V	Ta=-40°C ~ 85°C	-25%	30	25%	MHz
f _{LIRC}	System Clock (LIRC)	5V	Ta=25°C	-10%	32	+10%	kHz
		V _{LVR} ~5.5V	Ta=-40°C to 85°C	-30%	32	+60%	kHz
t _{TIMER}	TCKn Input Pin Minimum Pulse Width	—	—	—	150	—	ns
t _{INT}	Interrupt Minimum Pulse Width	—	—	1	3.3	5	µs
t _{EERD}	EEPROM Read Time	—	—	—	2	4	t _{sys}
t _{EEWR}	EEPROM Write Time	—	—	—	2	4	ms
t _{SST}	System Start-up Timer Period (Wake-up from HALT, f _{sys} off at HALT state)	—	f _{sys} =HIRC	10	16	22	t _{sys}
	System Start-up Timer Period (Wake-up from HALT, f _{sys} off at HALT state)	—	f _{sys} =LIRC	1	2	6	t _{sys}
	System Start-up Timer Period (Wake-up from HALT, f _{sys} on at HALT state)	—	f _{sys} =LIRC	1	2	6	t _{sys}
t _{RSTD}	System Reset Delay Time (Power On Reset)	—	—	25	50	100	ms
	System Reset Delay Time (Any Reset except Power On Reset)	—	—	8.3	16.7	33.3	ms

Note: 1. t_{sys}=1/f_{sys}

- To maintain the accuracy of the internal HIRC oscillator frequency, a 0.1µF decoupling capacitor should be connected between VDD and VSS and located as close to the device as possible.

LVD&LVR Electrical Characteristics

Ta=25°C

Symbol	Parameter	Test Conditions		Min.	Typ.	Max.	Unit
		V _{DD}	Conditions				
V _{LVR1}	Low Voltage Reset Voltage	—	LVR Enable, 2.55V option	-5%	2.55	+5%	V
V _{LVD1}	Low Voltage Detector Voltage	—	LVDEN = 1, V _{LVD} = 2V	-5%	2	+5%	V
V _{LVD2}			LVDEN = 1, V _{LVD} = 2.2V		2.2		V
V _{LVD3}			LVDEN = 1, V _{LVD} = 2.4V		2.4		V
V _{LVD4}			LVDEN = 1, V _{LVD} = 2.7V		2.7		V
V _{LVD5}			LVDEN = 1, V _{LVD} = 3.0V		3.0		V
V _{LVD6}			LVDEN = 1, V _{LVD} = 3.3V		3.3		V
V _{LVD7}			LVDEN = 1, V _{LVD} = 3.6V		3.6		V
V _{LVD8}			LVDEN = 1, V _{LVD} = 4.0V		4.0		V
I _{LVD}	Additional Power Consumption if LVD is Used	3V	LVD disable → LVD enable	—	30	45	μA
		5V	(LVR enable)	—	60	90	μA
t _{LVR}	Low Voltage Width to Reset	—	—	120	240	480	μs
t _{LVD}	Low Voltage Width to Interrupt	—	—	60	120	240	μs
t _{LVDS}	LVDO Stable Time	—	For LVR enable, LVD off → on	—	—	15	μs
t _{SRESET}	Software Reset Width to Reset	—	—	45	90	120	μs

ADC Electrical Characteristics

Ta=25°C

Symbol	Parameter	Test Conditions		Min.	Typ.	Max.	Unit
		V _{DD}	Conditions				
AV _{DD}	A/D Converter Operating Voltage	—	—	2.7	—	5.5	V
V _{ADI}	A/D Converter Input Voltage	—	—	0	—	V _{REF}	V
V _{REF}	A/D Converter Reference Voltage	—	—	2	—	AV _{DD}	V
V _{BG}	Reference Voltage	—	—	-3%	1.25	+3%	V
DNL1	Differential Non-linearity	3V	No Load (t _{ADCK} = 4/(7.5MHz), f _{SYS} = 7.5MHz), ADC reference voltage = V _{REF} pin = 2.5V	-2	—	+3	LSB
		5V					
DNL2	Differential Non-linearity	3V	No Load (t _{ADCK} = 4/(7.5MHz), f _{SYS} = 7.5MHz), ADC reference voltage = AV _{DD}	-2	—	+3	LSB
		5V					
DNL3	Differential Non-linearity	3V	No Load (t _{ADCK} = 8/(15MHz), f _{SYS} = 15MHz), ADC reference voltage = V _{REF} pin = 2.5V	-2	—	+3	LSB
		5V					
INL1	Integral Non-linearity	3V	No Load (t _{ADCK} = 4/(7.5MHz), f _{SYS} = 7.5MHz), ADC reference voltage = V _{REF} pin = 2.5V	-4	—	+4	LSB
		5V					
INL2	Integral Non-linearity	3V	No Load (t _{ADCK} = 4/(7.5MHz), f _{SYS} = 7.5MHz), ADC reference voltage = AV _{DD}	-4	—	+4	LSB
		5V					
INL3	Integral Non-linearity	3V	No Load (t _{ADCK} = 8/(15MHz), f _{SYS} = 15MHz), ADC reference voltage = V _{REF} pin = 2.5V	-4	—	+4	LSB
		5V					
I _{ADC}	Additional Power Consumption if A/D Converter is Used	3V	No load (t _{ADCK} = 0.53μs)	—	0.9	1.35	mA
		5V	No load (t _{ADCK} = 0.53μs)	—	1.2	1.8	mA
I _{BG}	Additional Power Consumption if V _{BG} Reference with Buffer is used	—	—	—	200	300	μA
t _{ADCK}	A/D Converter Clock Period	—	—	0.53	—	10	μs

Symbol	Parameter	Test Conditions		Min.	Typ.	Max.	Unit
		V _{DD}	Conditions				
t _{ADC}	A/D Conversion Time (Include Sample and Hold Time)	—	12-bit ADC	—	16	—	t _{ADCK}
t _{ADS}	A/D Converter Sampling Time	—	—	—	4	—	t _{ADCK}
t _{ON2ST}	A/D Converter On-to-Start Time	—	—	2	—	—	μs
t _{BGS}	V _{BG} Turn on Stable Time	—	—	200	—	—	μs

Over/Under Voltage Circuit Electrical Characteristics

Ta= 25°C

Symbol	Parameter	Test Conditions		Min.	Typ.	Max.	Unit
		V _{DD}	Conditions				
V _{OUIV}	OUIV Operating Voltage	—	—	2.7	—	5.5	V
I _{OVP}	OVP Operating Current	3V	OVP Enable	—	0.30	0.50	mA
		5V		—	0.45	0.60	mA
I _{UVP}	UVP Operating Current	3V	UVP Enable	—	0.30	0.50	mA
		5V		—	0.45	0.60	mA
I _{OUIVSD}	OUIV Shutdown Current	—	No Load	—	—	0.1	μA
OUIV Comparator							
V _{CMPOS}	Comparator Input Offset Voltage	3V/5V	—	-10	—	10	mV
V _{HYS}	Comparator Hysteresis Width	3V/5V	—	20	40	60	mV
V _{CM}	Comparator Common Mode Voltage Range	3V/5V	—	V _{SS}	—	V _{DD} -1.4	V
A _{OL}	Comparator Open Loop Gain	3V/5V	—	60	80	—	dB
t _{PD}	Comparator Response Time	3V/5V	With 100mV overdrive	—	370	560	ns
DAC for OUIV							
Resolution	DAC Resolution	—	—	—	8	—	bits
DNL	DAC Differential NonLinearity	—	—	-0.5	—	0.5	LSB
INL	DAC Integral NonLinearity	—	—	-1	—	1	LSB
OVP ERR							
ERR	The Error for OVP & DAC Value	3V	Comparator Hysteris off, DAC V _{REF} =1/2 V _{DD}	-20	—	20	mV
		5V		-30	—	30	mV
UVP ERR							
ERR	The Error for UVP & DAC Value	3V	Comparator Hysteris off, DAC V _{REF} =1/2 V _{DD}	-20	—	20	mV
		5V		-30	—	30	mV

Over Current Circuit Electrical Characteristics

Ta=25°C

Symbol	Parameter	Test Conditions		Min.	Typ.	Max.	Unit
		V _{DD}	Conditions				
V _{OCP}	OCP Operation Voltage	—	—	2.7	—	5.5	V
I _{OCP}	OCP Operation Current	3V	OCP enable, DAC V _{REF} =2.5V	—	300	500	μA
		5V		—	480	710	μA
OCP Comaprator							
I _{CMP}	Comparator Operating Current	5V	No load	—	30	60	μA
V _{CMPOS}	Comparator Input Offset Voltage	5V	Without calibration, Calibration bits [4:0]=10000B	-15	—	15	mV
		5V	With calibration	-4	—	4	mV
V _{HYS}	Comparator Hysteresis Width	5V	—	20	40	60	mV
V _{CM}	Comparator Common Mode Voltage Range	5V	—	V _{SS}	—	V _{DD} -1.4	V
t _{PD}	Comparator Response Time	5V	With 100mV overdrive	—	370	560	ns
OCP OPA							
I _{OPA}	OPA operating Current	5V	No load	—	200	350	μA
V _{OPAOS}	OPA Input Offset Voltage	5V	Without calibration, Calibration bits [5:0]=100000B	-15	—	15	mV
			With calibration	-4	—	4	mV
V _{CM}	OPA Common Mode Voltage Range	5V	—	V _{SS}	—	V _{DD} -1.4	V
PSRR	Power Supply Rejection Ratio	5V	—	60	80	—	dB
CMRR	Common mode Rejection Ratio	5V	—	60	80	—	dB
SR	Slew Rate +, Slew Rate -	5V	—	1.8	2.5	—	V/μS
GBW	Gain Band Width	5V	—	500	—	—	kHz
GAIN	OPA Gain Err	5V	Gain=1/5/10/15/20/30	-5	G	5	%
DAC for OCP							
I _{DAC}	DAC Operating Current	5V	V _{REF} =2.5V	—	250	300	μA
		5V	V _{REF} =5V	—	500	600	μA
R _O	R2R Output Resistance	5V	—	—	10	—	kΩ
Resolution	DAC Resolution	—	—	—	8	—	bits
DNL	DAC Differential NonLinearity	—	—	-0.5	—	0.5	LSB
INL	DAC Integral NonLinearity	—	—	-1	—	1	LSB

Power on Reset Electrical Characteristics

Ta=25°C

Symbol	Parameter	Test Conditions		Min.	Typ.	Max.	Unit
		V _{DD}	Conditions				
V _{POR}	V _{DD} Start Voltage to Ensure Power-on Reset	—	—	—	—	100	mV
R _{POR}	V _{DD} Rising Rate to Ensure Power-on Reset	—	—	0.035	—	—	V/ms
t _{POR}	Minimum Time for V _{DD} Stays at V _{POR} to Ensure Power-on Reset	—	—	1	—	—	ms

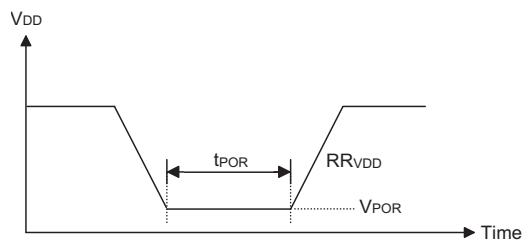

System Architecture

A key factor in the high-performance features of the Holtek range of microcontrollers is attributed to their internal system architecture. The device takes advantage of the usual features found within RISC microcontrollers providing increased speed of operation and Periodic performance. The pipelining scheme is implemented in such a way that instruction fetching and instruction execution are overlapped, hence instructions are effectively executed in one cycle, with the exception of branch or call instructions. An 8-bit wide ALU is used in practically all instruction set operations, which carries out arithmetic operations, logic operations, rotation, increment, decrement, branch decisions, etc. The internal data path is simplified by moving data through the Accumulator and the ALU. Certain internal registers are implemented in the Data Memory and can be directly or indirectly addressed. The simple addressing methods of these registers along with additional architectural features ensure that a minimum of external components is required to provide a functional I/O and A/D control system with maximum reliability and flexibility. This makes the device suitable for low-cost, high-volume production for controller applications.

Clocking and Pipelining

The main system clock, derived from either an HIRC or LIRC oscillator is subdivided into four internally generated non-overlapping clocks, T1~T4. The Program Counter is incremented at the beginning of the T1 clock during which time a new instruction is fetched. The remaining T2~T4 clocks carry out the decoding and execution functions. In this way, one T1~T4 clock cycle forms one instruction cycle. Although the fetching and execution of instructions takes place in consecutive instruction cycles, the pipelining structure of the microcontroller ensures that instructions are effectively executed in one instruction cycle. The exception to this are instructions where the contents of the Program Counter are changed, such as subroutine calls or jumps, in which case the instruction will take one more instruction cycle to execute.

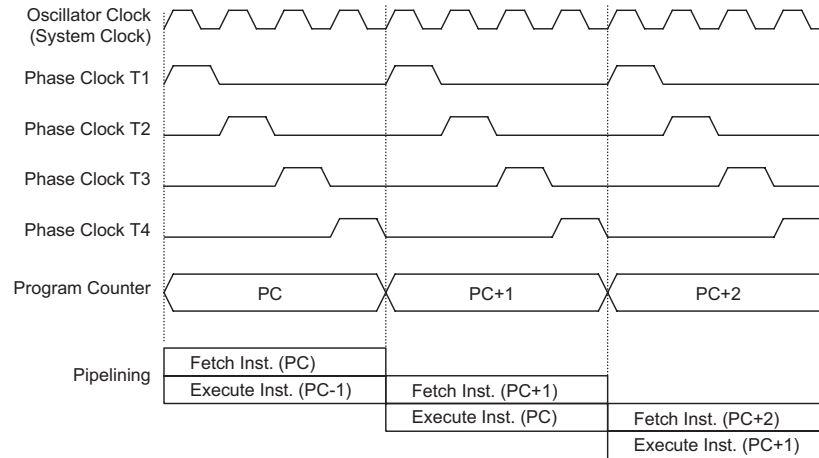

System Clock and Pipelining

For instructions involving branches, such as jump or call instructions, two machine cycles are required to complete instruction execution. An extra cycle is required as the program takes one cycle to first obtain the actual jump or call address and then another cycle to actually execute the branch. The requirement for this extra cycle should be taken into account by programmers in timing sensitive applications.

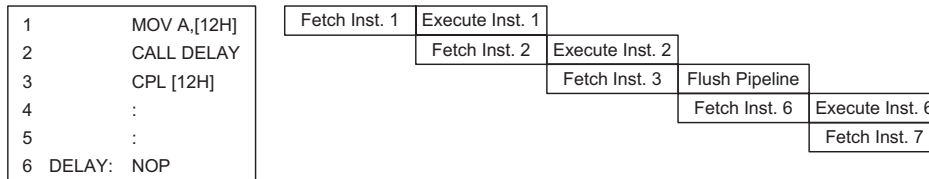

Instruction Fetching

Program Counter

During program execution, the Program Counter is used to keep track of the address of the next instruction to be executed. It is automatically incremented by one each time an instruction is executed except for instructions, such as “JMP” or “CALL” that demand a jump to a non-consecutive Program Memory address. Only the lower 8 bits, known as the Program Counter Low Register, are directly addressable by the application program.

When executing instructions requiring jumps to non-consecutive addresses such as a jump instruction, a subroutine call, interrupt or reset, etc., the microcontroller manages program control by loading the required address into the Program Counter. For conditional skip instructions, once the condition has been met, the next instruction, which has already been fetched during the present instruction execution, is discarded and a dummy cycle takes its place while the correct instruction is obtained.

Program Counter	
Program Counter High byte	PCL Register
PC10~PC8	PCL7~PCL0

The lower byte of the Program Counter, known as the Program Counter Low register or PCL, is available for program control and is a readable and writable register. By transferring data directly into this register, a short program jump can be executed directly, however, as only this low byte is available for manipulation, the jumps are limited to the present page of memory, that is 256 locations. When such program jumps are executed it should also be noted that a dummy cycle will be inserted. Manipulating the PCL register may cause program branching, so an extra cycle is needed to pre-fetch.

Stack

This is a special part of the memory which is used to save the contents of the Program Counter only. The stack is neither part of the data nor part of the program space, and is neither readable nor writeable. The activated level is indexed by the Stack Pointer, and is neither readable nor writeable. At a subroutine call or interrupt acknowledge signal, the contents of the Program Counter are pushed onto the stack. At the end of a subroutine or an interrupt routine, signaled by a return instruction, RET or RETI, the Program Counter is restored to its previous value from the stack. After a device reset, the Stack Pointer will point to the top of the stack.

If the stack is full and an enabled interrupt takes place, the interrupt request flag will be recorded but the acknowledge signal will be inhibited. When the Stack Pointer is decremented, by RET or RETI, the interrupt will be serviced. This feature prevents stack overflow allowing the programmer to use the structure more easily. However, when the stack is full, a CALL subroutine instruction can still be executed which will result in a stack overflow. Precautions should be taken to avoid such cases which might cause unpredictable program branching. If the stack is overflow, the first Program Counter save in the stack will be lost.

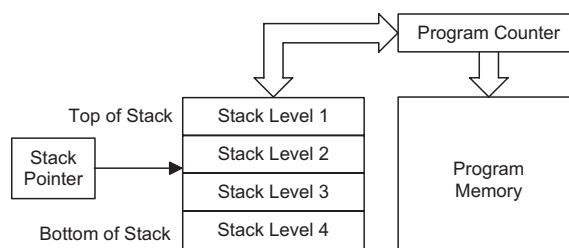

Arithmetic and Logic Unit – ALU

The arithmetic-logic unit or ALU is a critical area of the microcontroller that carries out arithmetic and logic operations of the instruction set. Connected to the main microcontroller data bus, the ALU receives related instruction codes and performs the required arithmetic or logical operations after which the result will be placed in the specified register. As these ALU calculation or operations may result in carry, borrow or other status changes, the status register will be correspondingly updated to reflect these changes. The ALU supports the following functions:

- Arithmetic operations: ADD, ADDM, ADC, ADCM, SUB, SUBM, SBC, SBCM, DAA
- Logic operations: AND, OR, XOR, ANDM, ORM, XORM, CPL, CPLA
- Rotation RRA, RR, RRCA, RRC, RLA, RL, RLCA, RLC
- Increment and Decrement INCA, INC, DECA, DEC
- Branch decision, JMP, SZ, SZA, SNZ, SIZ, SDZ, SIZA, SDZA, CALL, RET, RETI

Flash Program Memory

The Program Memory is the location where the user code or program is stored. For this device the Program Memory is Flash type, which means it can be programmed and re-programmed a large number of times, allowing the user the convenience of code modification on the same device. By using the appropriate programming tools, this Flash device offers users the flexibility to conveniently debug and develop their applications while also offering a means of field programming and updating.

Structure

The Program Memory has a capacity of 2K×16 bits. The Program Memory is addressed by the Program Counter and also contains data, table information and interrupt entries. Table data, which can be setup in any location within the Program Memory, is addressed by a separate table pointer register.

Special Vectors

Within the Program Memory, certain locations are reserved for the reset and interrupts. The location 000H is reserved for use by the device reset for program initialisation. After a device reset is initiated, the program will jump to this location and begin execution.

000H	Initialisation Vector
004H	OCP0 Interrupt Vector
008H	OCP1 Interrupt Vector
00CH	OVP Interrupt Vector
010H	UVP Interrupt Vector
014H	External Interrupt 0 Vector
018H	External Interrupt 1 Vector
01CH	Multi_Function Interrupt 0 Vector
020H	Multi_Function Interrupt 1 Vector
024H	Multi_Function Interrupt 2 Vector
028H	LVD Interrupt Vector
02CH	Time Base 0 Interrupt Vector
030H	Time Base1 Interrupt Vector
034H	A/D Interrupt Vector
038H	16 bits
7FFH	

Program Memory Structure

Look-up Table

Any location within the Program Memory can be defined as a look-up table where programmers can store fixed data. To use the look-up table, the table pointer must first be setup by placing the address of the look up data to be retrieved in the table pointer register, TBLP and TBHP. These registers define the total address of the look-up table.

After setting up the table pointer, the table data can be retrieved from the Program Memory using the “TABRD[m]” or “TABRDL[m]” instructions, respectively. When the instruction is executed, the lower order table byte from the Program Memory will be transferred to the user defined Data Memory register [m] as specified in the instruction. The higher order table data byte from the Program Memory will be transferred to the TBLH special register. Any unused bits in this transferred higher order byte will be read as “0”.

The accompanying diagram illustrates the addressing data flow of the look-up table.

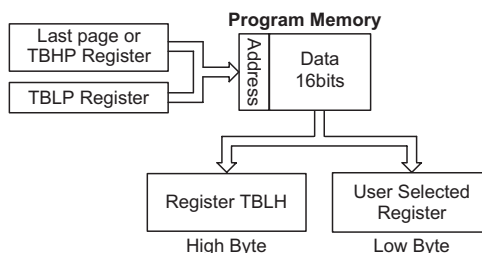

Instruction	Table Location Bits										
	b10	b9	b8	b7	b6	b5	b4	b3	b2	b1	b0
TABRD [m]	@10	@9	@8	@7	@6	@5	@4	@3	@2	@1	@0
TABRDL [m]	1	1	1	@7	@6	@5	@4	@3	@2	@1	@0

Table Location

Note: b10~b0: Table location bits

@7~@0: Table pointer (TBLP) bits

@10~@8: Table pointer (TBHP) bits

Table Program Example

The following example shows how the table pointer and table data is defined and retrieved from the microcontroller. This example uses raw table data located in the Program Memory which is stored there using the ORG statement. The value at this ORG statement is “700H” which refers to the start address of the last page within the 2K words Program Memory of the device. The table pointer is setup here to have an initial value of “06H”. This will ensure that the first data read from the data table will be at the Program Memory address “706H” or 6 locations after the start of the last page. Note that the value for the table pointer is referenced to the first address of the present page if the “TABRD [m]” instruction is being used. The high byte of the table data which in this case is equal to zero will be transferred to the TBLH register automatically when the “TABRD [m]” instruction is executed.

Because the TBLH register is a read-only register and cannot be restored, care should be taken to ensure its protection if both the main routine and Interrupt Service Routine use table read instructions. If using the table read instructions, the Interrupt Service Routines may change the value of the TBLH and subsequently cause errors if used again by the main routine. As a rule it is recommended that simultaneous use of the table read instructions should be avoided. However, in situations where simultaneous use cannot be avoided, the interrupts should be disabled prior to the

execution of any main routine table-read instructions. Note that all table related instructions require two instruction cycles to complete their operation.

Table Read Program Example

```

tempreg1 db ?      ; temporary register #1
tempreg2 db ?      ; temporary register #2
:
:
mov a,06h          ; initialise low table pointer - note that this address is referenced
mov tblp,a
mov a,07h          ; initialise high table pointer
mov tbhp,a
:
:
tabrd tempreg1     ; transfers value in table referenced by table pointer data at program
                  ; memory address "706H" transferred to tempreg1 and TBLH
dec tblp           ; reduce value of table pointer by one
tabrd tempreg2     ; transfers value in table referenced by table pointer data at program
                  ; memory address "705H" transferred to tempreg2 and TBLH in this
                  ; example the data "1AH" is transferred to tempreg1 and data "0FH" to
                  ; register tempreg2
:
:
org 700h           ; sets initial address of program memory
dc 00Ah, 00Bh, 00Ch, 00Dh, 00Eh, 00Fh, 01Ah, 01Bh
:
:

```

In Circuit Programming

The provision of Flash type Program Memory provides the user with a means of convenient and easy upgrades and modifications to their programs on the same device. As an additional convenience, Holtek has provided a means of programming the microcontroller in-circuit using a 4-pin interface. This provides manufacturers with the possibility of manufacturing their circuit boards complete with a programmed or un-programmed microcontroller, and then programming or upgrading the program at a later stage. This enables product manufacturers to easily keep their manufactured products supplied with the latest program releases without removal and re-insertion of the device.

The Holtek Flash MCU to Writer Programming Pin correspondence table is as follows:

Holtek Writer Pins	MCU Programming Pins	Function
ICPDA	PA6	Programming Serial Data/Address
ICPCK	PA7	Programming Serial Clock
VDD	VDD	Power Supply
VSS	VSS	Ground

During the programming process, the user must there take care to ensure that no other outputs are connected to these two pins.

The Program Memory and EEPROM data memory can both be programmed serially in-circuit using this 4-wire interface. Data is downloaded and uploaded serially on a single pin with an additional line for the clock. Two additional lines are required for the power supply. The technical details regarding the in-circuit programming of the device are beyond the scope of this document and will be supplied in supplementary literature.

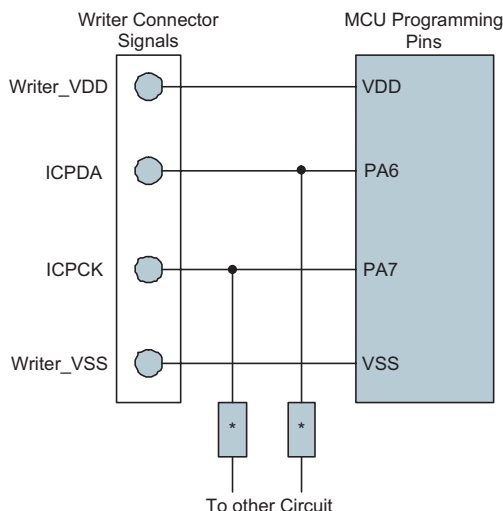

Note: * may be resistor or capacitor. The resistance of * must be greater than 1k or the capacitance of * must be less than 1nF.

On-Chip Debug Support – OCDS

An EV chip exists for the purposes of device emulation. This EV chip device also provides an “On-Chip Debug” function to debug the device during the development process. The EV chip and the actual MCU devices are almost functionally compatible except for the “On-Chip Debug” function. Users can use the EV chip device to emulate the real chip device behavior by connecting the OCSDA and OCDSCK pins to the Holtek HT-IDE development tools. The OCSDA pin is the OCDS Data/Address input/output pin while the OCDSCK pin is the OCDS clock input pin. When users use the EV chip for debugging, other functions which are shared with the OCSDA and OCDSCK pins in the actual MCU device will have no effect in the EV chip. However, the two OCDS pins which are pin-shared with the ICP programming pins are still used as the Flash Memory programming pins for ICP. For a more detailed OCDS description, refer to the corresponding document named “Holtek e-Link for 8-bit MCU OCDS User’s Guide”.

Holtek e-Link Pins	EV Chip Pins	Pin Description
OCSDA	OCSDA	On-chip Debug Support Data/Address input/output
OCDSCK	OCDSCK	On-chip Debug Support Clock input
VDD	VDD	Power Supply
GND	VSS	Ground

RAM Data Memory

The Data Memory is a volatile area of 8-bit wide RAM internal memory and is the location where temporary information is stored.

Structure

Divided into two sections, the first of these is an area of RAM, known as the Special Function Data Memory. Here are located registers which are necessary for correct operation of the device. Many of these registers can be read from and written to directly under program control, however, some remain protected from user manipulation. The second area of Data Memory is known as the General Purpose Data Memory, which is reserved for general purpose use. All locations within this area are read and write accessible under program control.

The overall Data Memory is subdivided into two banks. The Special Purpose Data Memory registers are accessible in all banks, with the exception of the EEC register at address 40H, which is only accessible in Bank 1. Switching between the different Data Memory banks is achieved by setting the Bank Pointer to the correct value. The start address of the Data Memory for the device is the address 00H.

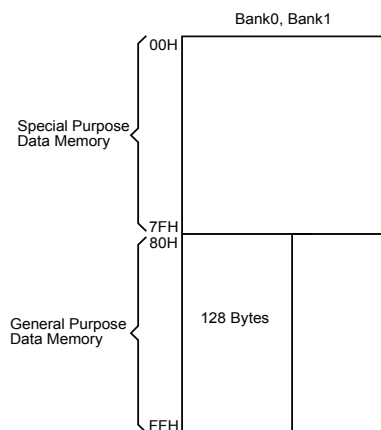

Data Memory Structure

Bank 0 Bank 1		Bank 0 Bank 1		
00H	IAR0	3AH	TM2DH	
01H	MP0	3BH	TM2AL	
02H	IAR1	3CH	TM2AH	
03H	MP1	3DH	Unused	
04H	BP	3EH	Unused	
05H	ACC	3FH	Unused	
06H	PCL	40H	Unused EEC	
07H	TBLP	41H	PB	
08H	TBLH	42H	PBC	
09H	TBHP	43H	PBJU	
0AH	STATUS	44H	PBPL	
0BH	SMOD	45H	PBWU	
0CH	LVDC	46H	PC	
0DH	INTEG	47H	PCC	
0EH	INTC0	48H	PCPU	
0FH	INTC1	49H	PAPS0	
10H	INTC2	4AH	PAPS1	
11H	INTC3	4BH	PBPS	
12H	MF10	4CH	PCPS	
13H	MF11	4DH	Unused	
14H	MF12	4EH	OCPC	
15H	PA	4FH	OCP0C1	
16H	PAC	50H	OCP0DA	
17H	PAPU	51H	AOCAL	
18H	PAWU	52H	COCAL	
19H	TMPC	53H	OCP1C1	
1AH	WDTC	54H	OCP1DA	
1BH	TBC	55H	A1CAL	
1CH	CPR	56H	C1CAL	
1DH	Unused	57H	OVPDA	
1EH	EEA	58H	UVPDA	
1FH	EED	59H	OUVPC0	
20H	ADRL	5AH	OUVPC1	
21H	ADRH	5BH	OUVPC2	
22H	ADCR0	5CH	ADJDT	
23H	ADCR1	5DH	ADJS	
24H	Unused	5EH	ADJC	
25H	Unused	5FH	ADJMaxH	
26H	CTRL	60H	ADJMaxL	
27H	LVRC	61H	ADJMinH	
28H	TM0C0	62H	ADJMinL	
29H	TM0C1	63H	ADJBH	
2AH	TM0DL	64H	ADJBL	
2BH	TM0DH	65H	Unused	
2CH	TM0AL	66H	Unused	
2DH	TM0AH	67H	SWS	
2EH	Unused	68H	Unused	
2FH	TM1C0		
30H	TM1C1		
31H	TM1DL		
32H	TM1DH		
33H	TM1AL		
34H	TM1AH		
35H	TM1RPL		
36H	M1RPH		
37H	TM2C0		
38H	TM2C1		
39H	TM2DL	7FH		

Unused, read as 0

Special Purpose Data Memory Structure

Special Function Register Description

Most of the Special Function Register details will be described in the relevant functional sections, however several registers require a separate description in this section.

Indirect Addressing Registers – IAR0, IAR1

The Indirect Addressing Registers, IAR0 and IAR1, although having their locations in normal RAM register space, do not actually physically exist as normal registers. The method of indirect addressing for RAM data manipulation uses these Indirect Addressing Registers and Memory Pointers, in contrast to direct memory addressing, where the actual memory address is specified. Actions on the IAR0 and IAR1 registers will result in no actual read or write operation to these registers but rather to the memory location specified by their corresponding Memory Pointers, MP0 or MP1. Acting as a pair, IAR0 and MP0 can together access data from Bank 0 while the IAR1 and MP1 register pair can access data from any bank. As the Indirect Addressing Registers are not physically implemented, reading the Indirect Addressing Registers indirectly will return a result of “00H” and writing to the registers indirectly will result in no operation.

Memory Pointers – MP0, MP1

Two Memory Pointers, known as MP0 and MP1 are provided. These Memory Pointers are physically implemented in the Data Memory and can be manipulated in the same way as normal registers providing a convenient way with which to address and track data. When any operation to the relevant Indirect Addressing Registers is carried out, the actual address that the microcontroller is directed to is the address specified by the related Memory Pointer. MP0, together with Indirect Addressing Register, IAR0, are used to access data from Bank 0, while MP1 and IAR1 are used to access data from all banks according to BP register. Direct Addressing can only be used with Bank 0, all other Banks must be addressed indirectly using MP1 and IAR1.

The following example shows how to clear a section of four Data Memory locations already defined as locations `adres1` to `adres4`.

Indirect Addressing Program Example

```
data .section 'data'
adres1 db ?
adres2 db ?
adres3 db ?
adres4 db ?
block db ?
code .section at 0 'code'
org00h
start:
    mov a,04h          ; setup size of block
    mov block,a
    mov a,offset adres1 ; Accumulator loaded with first RAM address
    mov mp0,a         ; setup memory pointer with first RAM address
loop:
    clr IAR0          ; clear the data at address defined by mp0
    inc mp0           ; increment memory pointer
    sdz block         ; check if last memory location has been cleared
    jmp loop
continue:
```

The important point to note here is that in the example shown above, no reference is made to specific Data Memory addresses.

Bank Pointer – BP

For this device, the Data Memory is divided into two banks, Bank0 and Bank1. Selecting the required Data Memory area is achieved using the Bank Pointer. Bit 0 of the Bank Pointer is used to select Data Memory Banks 0~1.

The Data Memory is initialised to Bank 0 after a reset, except for a WDT time-out reset in the Power Down Mode, in which case, the Data Memory bank remains unaffected. It should be noted that the Special Function Data Memory is not affected by the bank selection, which means that the Special Function Registers can be accessed from within any bank. Directly addressing the Data Memory will always result in Bank 0 being accessed irrespective of the value of the Bank Pointer. Accessing data from Bank1 must be implemented using Indirect Addressing.

BP Register

Bit	7	6	5	4	3	2	1	0
Name	—	—	—	—	—	—	—	DMBP0
R/W	—	—	—	—	—	—	—	R/W
POR	—	—	—	—	—	—	—	0

Bit 7~1 Unimplemented, read as “0”

Bit 0 **DMBP0**: Select Data Memory Banks
0: Bank 0
1: Bank 1

Accumulator – ACC

The Accumulator is central to the operation of any microcontroller and is closely related with operations carried out by the ALU. The Accumulator is the place where all intermediate results from the ALU are stored. Without the Accumulator it would be necessary to write the result of each calculation or logical operation such as addition, subtraction, shift, etc., to the Data Memory resulting in higher programming and timing overheads. Data transfer operations usually involve the temporary storage function of the Accumulator; for example, when transferring data between one user-defined register and another, it is necessary to do this by passing the data through the Accumulator as no direct transfer between two registers is permitted.

Program Counter Low Register – PCL

To provide additional program control functions, the low byte of the Program Counter is made accessible to programmers by locating it within the Special Purpose area of the Data Memory. By manipulating this register, direct jumps to other program locations are easily implemented. Loading a value directly into this PCL register will cause a jump to the specified Program Memory location, however, as the register is only 8-bit wide, only jumps within the current Program Memory page are permitted. When such operations are used, note that a dummy cycle will be inserted.

Look-up Table Registers – TBLP, TBHP, TBLH

These three special function registers are used to control operation of the look-up table which is stored in the Program Memory. TBLP and TBHP are the table pointers and indicate the location where the table data is located. Their value must be setup before any table read commands are executed. Their value can be changed, for example using the “INC” or “DEC” instructions, allowing for easy table data pointing and reading. TBLH is the location where the high order byte of the table data is stored after a table read data instruction has been executed. Note that the lower order table data byte is transferred to a user defined location.

Status Register – STATUS

This 8-bit register contains the zero flag (Z), carry flag (C), auxiliary carry flag (AC), overflow flag (OV), power down flag (PDF), and watchdog time-out flag (TO). These arithmetic/logical operation and system management flags are used to record the status and operation of the microcontroller.

With the exception of the TO and PDF flags, bits in the status register can be altered by instructions like most other registers. Any data written into the status register will not change the TO or PDF flag. In addition, operations related to the status register may give different results due to the different instruction operations. The TO flag can be affected only by a system power-up, a WDT time-out or by executing the “CLR WDT” or “HALT” instruction. The PDF flag is affected only by executing the “HALT” or “CLR WDT” instruction or during a system power-up.

The Z, OV, AC and C flags generally reflect the status of the latest operations.

- C is set if an operation results in a carry during an addition operation or if a borrow does not take place during a subtraction operation; otherwise C is cleared. C is also affected by a rotate through carry instruction.
- AC is set if an operation results in a carry out of the low nibbles in addition, or no borrow from the high nibble into the low nibble in subtraction; otherwise AC is cleared.
- Z is set if the result of an arithmetic or logical operation is zero; otherwise Z is cleared.
- OV is set if an operation results in a carry into the highest-order bit but not a carry out of the highest-order bit, or vice versa; otherwise OV is cleared.
- PDF is cleared by a system power-up or executing the “CLR WDT” instruction. PDF is set by executing the “HALT” instruction.
- TO is cleared by a system power-up or executing the “CLR WDT” or “HALT” instruction. TO is set by a WDT time-out.

In addition, on entering an interrupt sequence or executing a subroutine call, the status register will not be pushed onto the stack automatically. If the contents of the status registers are important and if the subroutine can corrupt the status register, precautions must be taken to correctly save it.

STATUS Register

Bit	7	6	5	4	3	2	1	0
Name	—	—	TO	PDF	OV	Z	AC	C
R/W	—	—	R	R	R/W	R/W	R/W	R/W
POR	—	—	0	0	x	x	x	x

"x": unknown

- Bit 7~6 Unimplemented, read as “0”
- Bit 5 **TO:** Watchdog Time-Out flag
 0: After power up or executing the "CLR WDT" or "HALT" instruction
 1: A watchdog time-out occurred.
- Bit 4 **PDF:** Power down flag
 0: After power up or executing the "CLR WDT" instruction
 1: By executing the "HALT" instruction
- Bit 3 **OV:** Overflow flag
 0: No overflow
 1: An operation results in a carry into the highest-order bit but not a carry out of the highest-order bit or vice versa.
- Bit 2 **Z:** Zero flag
 0: The result of an arithmetic or logical operation is not zero
 1: The result of an arithmetic or logical operation is zero
- Bit 1 **AC:** Auxiliary flag
 0: No auxiliary carry
 1: An operation results in a carry out of the low nibbles in addition, or no borrow from the high nibble into the low nibble in subtraction
- Bit 0 **C:** Carry flag
 0: No carry-out
 1: An operation results in a carry during an addition operation or if a borrow does not take place during a subtraction operation
 C is also affected by a rotate through carry instruction.

EEPROM Data Memory

One of the special features in the device is its internal EEPROM Data Memory. EEPROM, which stands for Electrically Erasable Programmable Read Only Memory, is by its nature a non-volatile form of memory, with data retention even when its power supply is removed. By incorporating this kind of data memory, a whole new host of application possibilities are made available to the designer. The availability of EEPROM storage allows information such as product identification numbers, calibration values, specific user data, system setup data or other product information to be stored directly within the product microcontroller. The process of reading and writing data to the EEPROM memory has been reduced to a very trivial affair.

EEPROM Data Memory Structure

The EEPROM Data Memory capacity is up to 64×8 bits. Unlike the Program Memory and RAM Data Memory, the EEPROM Data Memory is not directly mapped and is therefore not directly accessible in the same way as the other types of memory. Read and Write operations to the EEPROM are carried out in single byte operations using an address and data register in Bank 0 and a single control register in Bank 1.

EEPROM Registers

Three registers control the overall operation of the internal EEPROM Data Memory. These are the address register, EEA, the data register, EED and a single control register, EEC. As both the EEA and EED registers are located in Bank 0, they can be directly accessed in the same way as any other Special Function Register. The EEC register however, being located in Bank1, cannot be directly addressed directly and can only be read from or written to indirectly using the MP1 Memory Pointer and Indirect Addressing Register, IAR1. Because the EEC control register is located at address 40H in Bank 1, the MP1 Memory Pointer must first be set to the value 40H and the Bank Pointer register, BP, set to the value, 01H, before any operations on the EEC register are executed.

Register Name	Bit							
	7	6	5	4	3	2	1	0
EEA	—	—	D5	D4	D3	D2	D1	D0
EED	D7	D6	D5	D4	D3	D2	D1	D0
EEC	—	—	—	—	WREN	WR	RDEN	RD

EEPROM Control Registers List

EEA Register

Bit	7	6	5	4	3	2	1	0
Name	—	—	D5	D4	D3	D2	D1	D0
R/W	—	—	R/W	R/W	R/W	R/W	R/W	R/W
POR	—	—	0	0	0	0	0	0

Bit 7~6 Unimplemented, read as “0”
 Bit 5~0 Data EEPROM address
 Data EEPROM address bit 5 ~ bit 0

EED Register

Bit	7	6	5	4	3	2	1	0
Name	D7	D6	D5	D4	D3	D2	D1	D0
R/W	R/W	R/W	R/W	R/W	R/W	R/W	R/W	R/W
POR	0	0	0	0	0	0	0	0

Bit 7~0 Data EEPROM data
 Data EEPROM data bit 7 ~ bit 0

EEC Register

Bit	7	6	5	4	3	2	1	0
Name	—	—	—	—	WREN	WR	RDEN	RD
R/W	—	—	—	—	R/W	R/W	R/W	R/W
POR	—	—	—	—	0	0	0	0

Bit 7~4 Unimplemented, read as “0”

Bit 3 **WREN:** Data EEPROM Write Enable
 0: Disable
 1: Enable
 This is the Data EEPROM Write Enable Bit which must be set high before Data EEPROM write operations are carried out. Clearing this bit to zero will inhibit Data EEPROM write operations.

Bit 2 **WR:** EEPROM Write Control
 0: Write cycle has finished
 1: Activate a write cycle
 This is the Data EEPROM Write Control Bit and when set high by the application program will activate a write cycle. This bit will be automatically reset to zero by the hardware after the write cycle has finished. Setting this bit high will have no effect if the WREN has not first been set high.

Bit 1 **RDEN:** Data EEPROM Read Enable
 0: Disable
 1: Enable
 This is the Data EEPROM Read Enable Bit which must be set high before Data EEPROM read operations are carried out. Clearing this bit to zero will inhibit Data EEPROM read operations.

Bit 0 **RD:** EEPROM Read Control
 0: Read cycle has finished
 1: Activate a read cycle
 This is the Data EEPROM Read Control Bit and when set high by the application program will activate a read cycle. This bit will be automatically reset to zero by the hardware after the read cycle has finished. Setting this bit high will have no effect if the RDEN has not first been set high.

Note: The WREN, WR, RDEN and RD can not be set to “1” at the same time in one instruction. The WR and RD can not be set to “1” at the same time.

Reading Data from the EEPROM

To read data from the EEPROM, the read enable bit, RDEN, in the EEC register must first be set high to enable the read function. The EEPROM address of the data to be read must then be placed in the EEA register. If the RD bit in the EEC register is now set high, a read cycle will be initiated. Setting the RD bit high will not initiate a read operation if the RDEN bit has not been set. When the read cycle terminates, the RD bit will be automatically cleared to zero, after which the data can be read from the EED register. The data will remain in the EED register until another read or write operation is executed. The application program can poll the RD bit to determine when the data is valid for reading.

Writing Data to the EEPROM

The EEPROM address of the data to be written must first be placed in the EEA register and the data placed in the EED register. To write data to the EEPROM, the write enable bit, WREN, in the EEC register must first be set high to enable the write function. After this, the WR bit in the EEC register must be immediately set high to initiate a write cycle. These two instructions must be executed consecutively. The global interrupt bit EMI should also first be cleared before implementing any write operations, and then set again after the write cycle has started. Setting the WR bit high will not initiate a write cycle if the WREN bit has not been set. As the EEPROM write cycle is controlled using an internal timer whose operation is asynchronous to microcontroller system clock, a certain time will elapse before the data will have been written into the EEPROM. Detecting when the write cycle has finished can be implemented either by polling the WR bit in the EEC register or by using the EEPROM interrupt. When the write cycle terminates, the WR bit will be automatically cleared to zero by the microcontroller, informing the user that the data has been written to the EEPROM. The application program can therefore poll the WR bit to determine when the write cycle has ended.

Write Protection

Protection against inadvertent write operation is provided in several ways. After the device is powered-on the Write Enable bit in the control register will be cleared preventing any write operations. Also at power-on the Bank Pointer, BP, will be reset to zero, which means that Data Memory Bank 0 will be selected. As the EEPROM control register is located in Bank 1, this adds a further measure of protection against spurious write operations. During normal program operation, ensuring that the Write Enable bit in the control register is cleared will safeguard against incorrect write operations.

EEPROM Interrupt

The EEPROM write interrupt is generated when an EEPROM write cycle has ended. The EEPROM interrupt must first be enabled by setting the DEE bit in the relevant interrupt register. However as the EEPROM is contained within a Multi-function Interrupt, the associated multi-function interrupt enable bit must also be set. When an EEPROM write cycle ends, the DEF request flag and its associated multi-function interrupt request flag will both be set. If the global, EEPROM and Multi-function interrupts are enabled and the stack is not full, a jump to the associated Multi-function Interrupt vector will take place. When the interrupt is serviced only the Multi-function interrupt flag will be automatically reset, the EEPROM interrupt flag must be manually reset by the application program. More details can be obtained in the Interrupt section.

Programming Considerations

Care must be taken that data is not inadvertently written to the EEPROM. Protection can be Periodic by ensuring that the Write Enable bit is normally cleared to zero when not writing. Also the Bank Pointer could be normally cleared to zero as this would inhibit access to Bank 1 where the EEPROM control register exist. Although certainly not necessary, consideration might be given in the application program to the checking of the validity of new write data by a simple read back process. When writing data the WR bit must be set high immediately after the WREN bit has been set high, to ensure the write cycle executes correctly. The global interrupt bit EMI should also be cleared before a write cycle is executed and then re-enabled after the write cycle starts. Note that the device should not enter the IDLE or SLEEP mode until the EEPROM read or write operation is totally complete. Otherwise, the EEPROM read or write operation will fail.

Programming Examples

• Reading data from the EEPROM – polling method

```
MOV A, EEPROM_ADRES      ; user defined address
MOV EEA, A
MOV A, 040H              ; setup memory pointer MP1
MOV MP1, A               ; MP1 points to EEC register
MOV A, 01H               ; setup Bank Pointer
MOV BP, A
SET IAR1.1               ; set RDEN bit, enable read operations
SET IAR1.0               ; start Read Cycle - set RD bit
BACK:
SZ IAR1.0                ; check for read cycle end
JMP BACK
CLR IAR1                 ; disable EEPROM read/write
CLR BP
MOV A, EED               ; move read data to register
MOV READ_DATA, A
```

• Writing Data to the EEPROM – polling method

```
CLR EMI
MOV A, EEPROM_ADRES     ; user defined address
MOV EEA, A
MOV A, EEPROM_DATA      ; user defined data
MOV EED, A
MOV A, 040H              ; setup memory pointer MP1
MOV MP1, A               ; MP1 points to EEC register
MOV A, 01H               ; setup Bank Pointer
MOV BP, A
CLR EMI
SET IAR1.3               ; set WREN bit, enable write operations
SET IAR1.2               ; start Write Cycle - set WR bit
SET EMI
BACK:
SZ IAR1.2                ; check for write cycle end
JMP BACK
CLR IAR1                 ; disable EEPROM read/write
CLR BP
```

Oscillator

Various oscillator options offer the user a wide range of functions according to their various application requirements. The flexible features of the oscillator functions ensure that the best optimisation can be achieved in terms of speed and power saving. Oscillator selections and operation are selected through registers.

Oscillator Overview

In addition to being the source of the main system clock the oscillators also provide clock sources for the Watchdog Timer and Time Base Interrupts. Fully integrated internal oscillators, requiring no external components, are provided to form a wide range of both fast and slow system oscillators. The higher frequency oscillators provide higher performance but carry with it the disadvantage of higher power requirements, while the opposite is of course true for the lower frequency oscillators. With the capability of dynamically switching between fast and slow system clock, the device has the flexibility to optimize the performance/power ratio, a feature especially important in power sensitive portable applications.

Type	Name	Freq.
Internal High Speed RC	HIRC	30MHz
Internal Low Speed RC	LIRC	32kHz

Oscillator Types

System Clock Configurations

There are two methods of generating the system clock, a high speed oscillator and a low speed oscillator. The high speed oscillator is the internal 30MHz RC oscillator. The low speed oscillator is the internal 32kHz (LIRC) oscillator. Selecting whether the low or high speed oscillator is used as the system oscillator is implemented using the HLCLK bit and CKS2~CKS0 bits in the SMOD register and as the system clock can be dynamically selected.

The actual source clock used for the high speed and the low speed oscillators is chosen via registers. The frequency of the slow speed or high speed system clock is also determined using the HLCLK bit and CKS2~CKS0 bits in the SMOD register. Note that two oscillator selections must be made namely one high speed and one low speed system oscillators. It is not possible to choose a no-oscillator selection for either the high or low speed oscillator.

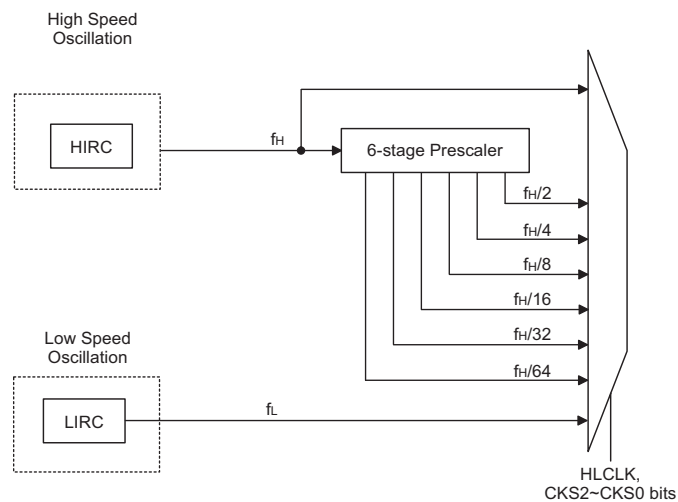

System Clock Configurations

Internal RC Oscillator – HIRC

The internal RC oscillator is a fully integrated system oscillator requiring no external components. The internal RC oscillator has a fixed frequency of 30MHz. Device trimming during the manufacturing process and the inclusion of internal frequency compensation circuits are used to ensure that the influence of the power supply voltage, temperature and process variations on the oscillation frequency are minimised. As a result, at a power supply of 5V and at temperature of 25°C degrees, the fixed oscillation frequency of the HIRC will have a tolerance within 2%. Note that if this internal system clock option is selected, as it requires no external pins for its operation.

Internal 32kHz Oscillator – LIRC

The Internal 32kHz System Oscillator is the low frequency oscillator. It is a fully integrated RC oscillator with a typical frequency of 32kHz at 5V, requiring no external components for its implementation. Device trimming during the manufacturing process and the inclusion of internal frequency compensation circuits are used to ensure that the influence of the power supply voltage, temperature and process variations on the oscillation frequency are minimised. As a result, at a power supply of 5V and at a temperature of 25°C degrees, the fixed oscillation frequency of 32kHz will have a tolerance within 10%.

Operating Modes and System Clocks

Present day applications require that their microcontrollers have high performance but often still demand that they consume as little power as possible, conflicting requirements that are especially true in battery powered portable applications. The fast clocks required for high performance will by their nature increase current consumption and of course vice-versa, lower speed clocks reduce current consumption. As Holtek has provided this device with both high and low speed clock sources and the means to switch between them dynamically, the user can optimise the operation of their microcontroller to achieve the best performance/power ratio.

System Clocks

The device has many different clock sources for both the CPU and peripheral function operation. By providing the user with a wide range of clock options using configuration options and register programming, a clock system can be configured to obtain maximum application performance.

The main system clock, can come from either a high frequency, f_H , or low frequency, f_L , source, and is selected using the HLCLK bit and CKS2~CKS0 bits in the SMOD register. The high speed system clock can be sourced from the HIRC oscillator. The low speed system clock source can be sourced from the LIRC oscillator. The other choice, which is a divided version of the high speed system oscillator has a range of $f_H/2 \sim f_H/64$.

There are two additional internal clocks for the peripheral circuits, the substitute clock, f_{SUB} , and the Time Base clock, f_{TBC} . Each of these internal clocks are sourced by the LIRC oscillator. The f_{SUB} clock is used to provide a substitute clock for the microcontroller just after a wake-up has occurred to enable faster wake-up times.

The f_{TBC} clock is used as a source for the Time Base interrupt functions and for the TMs.

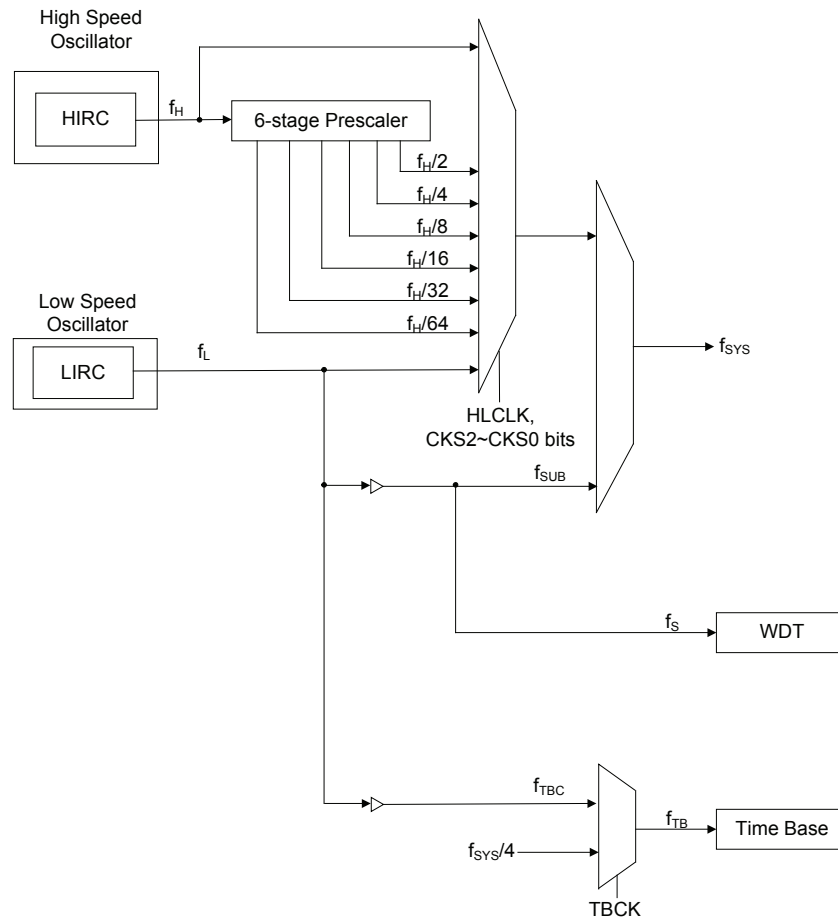

System Clock Configurations

Note: When the system clock source f_{SYS} is switched to f_L from f_H , the high speed oscillation will stop to conserve the power. Thus there is no $f_H \sim f_H/64$ for peripheral circuit to use.

System Operation Modes

There are five different modes of operation for the microcontroller, each one with its own special characteristics and which can be chosen according to the specific performance and power requirements of the application. There are two modes allowing normal operation of the microcontroller, the NORMAL Mode and SLOW Mode. The remaining three modes, the SLEEP, IDLE0 and IDLE1 Mode are used when the microcontroller CPU is switched off to conserve power.

Operating Mode	Description				
	CPU	f_{SYS}	f_{SUB}	f_S	f_{TBC}
Normal mode	On	$f_H \sim f_H/64$	On	On	On
Slow mode	On	f_L	On	On	On
IDLE0 mode	Off	Off	On	On	On
IDLE1 mode	Off	On	On	On	On
SLEEP mode (WDT enable)	Off	Off	On	On	Off

NORMAL Mode

As the name suggests this is one of the main operating modes where the microcontroller has all of its functions operational and where the system clock is provided by the high speed oscillator. This mode operates allowing the microcontroller to operate normally with a clock source will come from the high speed oscillator, HIRC. The high speed oscillator will however first be divided by a ratio ranging from 1 to 64, the actual ratio being selected by the CKS2~CKS0 and HLCLK bits in the SMOD register. Although a high speed oscillator is used, running the microcontroller at a divided clock ratio reduces the operating current.

SLOW Mode

This is also a mode where the microcontroller operates normally although now with a slower speed clock source. The clock source used will be from the LIRC. Running the microcontroller in this mode allows it to run with much lower operating currents. In the SLOW Mode, the f_{H} is off.

SLEEP Mode

The SLEEP Mode is entered when an HALT instruction is executed and when the IDLEN bit in the SMOD register is low. In the SLEEP mode the CPU will be stopped. However the f_{SUB} and f_S clocks will continue to operate.

IDLE0 Mode

The IDLE0 Mode is entered when a HALT instruction is executed and when the IDLEN bit in the SMOD register is high and the FSYSON bit in the CTRL register is low. In the IDLE0 Mode the system oscillator will be inhibited from driving the CPU, the system oscillator will be stopped, the low frequency clock f_{SUB} will be on.

IDLE1 Mode

The IDLE1 Mode is entered when a HALT instruction is executed and when the IDLEN bit in the SMOD register is high and the FSYSON bit in the CTRL register is high. In the IDLE1 Mode the system oscillator will be inhibited from driving the CPU, the system oscillator will continue to run, and this system oscillator may be high speed or low speed system oscillator. In the IDLE1 Mode the low frequency clock f_{SUB} and the Watchdog Timer clock, f_S , will be on.

Control Register

The SMOD register is used to control the internal clocks within the device.

SMOD Register

Bit	7	6	5	4	3	2	1	0
Name	CKS2	CKS1	CKS0	—	LTO	HTO	IDLEN	HLCLK
R/W	R/W	R/W	R/W	—	R	R	R/W	R/W
POR	1	1	0	—	0	0	1	0

Bit 7~5 **CKS2~CKS0:** The system clock selection when HLCLK is “0”

000: f_L
 001: f_L
 010: $f_H/64$
 011: $f_H/32$
 100: $f_H/16$
 101: $f_H/8$
 110: $f_H/4$
 111: $f_H/2$

These three bits are used to select which clock is used as the system clock source. In addition to the system clock source, which can be LIRC, a divided version of the high speed system oscillator can also be chosen as the system clock source.

Bit 4	Unimplemented, read as “0”
Bit 3	LTO: LIRC System OSC SST ready flag 0: Not ready 1: Ready This is the low speed system oscillator SST ready flag which indicates when the low speed system oscillator is stable after power on reset or a wake-up has occurred. The flag will change to a high level after 1~2 cycles.
Bit 2	HTO: HIRC System OSC SST ready flag 0: Not ready 1: Ready This is the high speed system oscillator SST ready flag which indicates when the high speed system oscillator is stable after a wake-up has occurred. This flag is cleared to “0” by hardware when the device is powered on and then changes to a high level after the high speed system oscillator is stable. Therefore this flag will always be read as “1” by the application program after device power-on. The flag will be low when in the SLEEP or IDLE0 Mode but after power on reset or a wake-up has occurred, the flag will change to a high level after 15~16 clock cycles if the HIRC oscillator is used.
Bit 1	IDLEN: IDLE Mode Control 0: Disable 1: Enable This is the IDLE Mode Control bit and determines what happens when the HALT instruction is executed. If this bit is high, when a HALT instruction is executed the device will enter the IDLE Mode. In the IDLE1 Mode the CPU will stop running but the system clock will continue to keep the peripheral functions operational, if FSYSON bit is high. If FSYSON bit is low, the CPU and the system clock will all stop in IDLE0 mode. If the bit is low the device will enter the SLEEP Mode when a HALT instruction is executed.
Bit 0	HLCLK: System Clock Selection 0: $f_H/2 \sim f_H/64$ or f_L 1: f_H This bit is used to select if the f_H clock or the $f_H/2 \sim f_H/64$ or f_L clock is used as the system clock. When the bit is high the f_H clock will be selected and if low the $f_H/2 \sim f_H/64$ or f_L clock will be selected. When system clock switches from the f_H clock to the f_L clock and the f_H clock will be automatically switched off to conserve power.

CTRL Register

Bit	7	6	5	4	3	2	1	0
Name	FSYSON	—	—	—	—	LVRF	LRF	WRF
R/W	R/W	—	—	—	—	R/W	R/W	R/W
POR	0	—	—	—	—	x	0	0

"x": unknown

- Bit 7 **FSYSON:** f_{sys} Control in IDLE Mode
 0: Disable
 1: Enable
- Bit 6~3 Unimplemented, read as “0”
- Bit 2 **LVRF:** Reset caused by LVR function activation
 0: Not occur
 1: Occurred
 This bit is set to 1 when a specific Low Voltage Reset situation condition occurs. This bit can only be cleared to 0 by the application program.
- Bit 1 **LRF:** Reset caused by LVRC setting
 0: Not occur
 1: Occurred
 This bit is set to 1 if the LVRC register contains any non defined LVR voltage register values. This in effect acts like a software reset function. This bit can only be cleared to 0 by the application program.
- Bit 0 **WRF:** Reset caused by WE[4:0] setting
 0: Not occur
 1: Occurred
 This bit is set to 1 by the WDT Control register software reset and cleared by the application program. Note that this bit can only be cleared to 0 by the application program.

Operating Mode Switching

The device can switch between operating modes dynamically allowing the user to select the best performance/power ratio for the present task in hand. In this way microcontroller operations that do not require high performance can be executed using slower clocks thus requiring less operating current and prolonging battery life in portable applications.

In simple terms, Mode Switching between the NORMAL Mode and SLOW Mode is executed using the HLCLK bit and CKS2~CKS0 bits in the SMOD register while Mode Switching from the NORMAL/SLOW Modes to the SLEEP/IDLE Modes is executed via the HALT instruction. When a HALT instruction is executed, whether the device enters the IDLE Mode or the SLEEP Mode is determined by the condition of the IDLEN bit in the SMOD register and FSYSON in the CTRL register.

When the HLCLK bit switches to a low level, which implies that clock source is switched from the high speed clock source, f_H , to the clock source, $f_H/2 \sim f_H/64$ or f_L . If the clock is from the f_L , the high speed clock source will stop running to conserve power. When this happens it must be noted that the $f_H/16$ and $f_H/64$ internal clock sources will also stop running, which may affect the operation of other internal functions such as the TMs. The accompanying flowchart shows what happens when the device moves between the various operating modes.

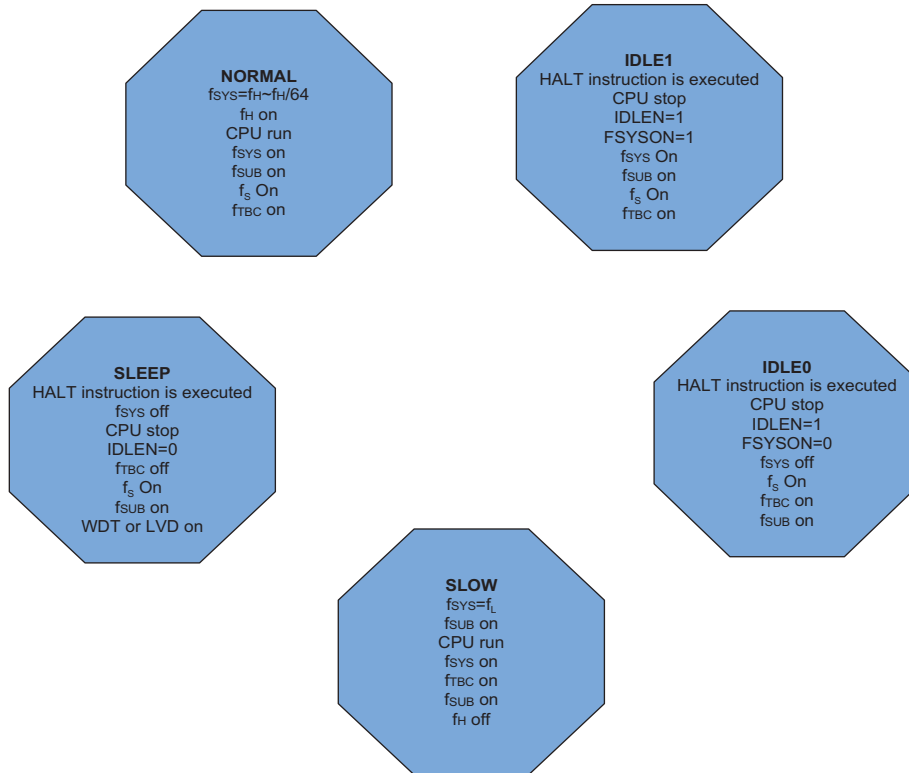

NORMAL Mode to SLOW Mode Switching

When running in the NORMAL Mode, which uses the high speed system oscillator, and therefore consumes more power, the system clock can switch to run in the SLOW Mode by setting the HLCLK bit to “0” and setting the CKS2~CKS0 bits to “000” or “001” in the SMOD register. This will then use the low speed system oscillator which will consume less power. Users may decide to do this for certain operations which do not require high performance and can subsequently reduce power consumption.

The SLOW Mode is sourced from the LIRC oscillator and therefore requires this oscillator to be stable before full mode switching occurs. This is monitored using the LTO bit in the SMOD register.

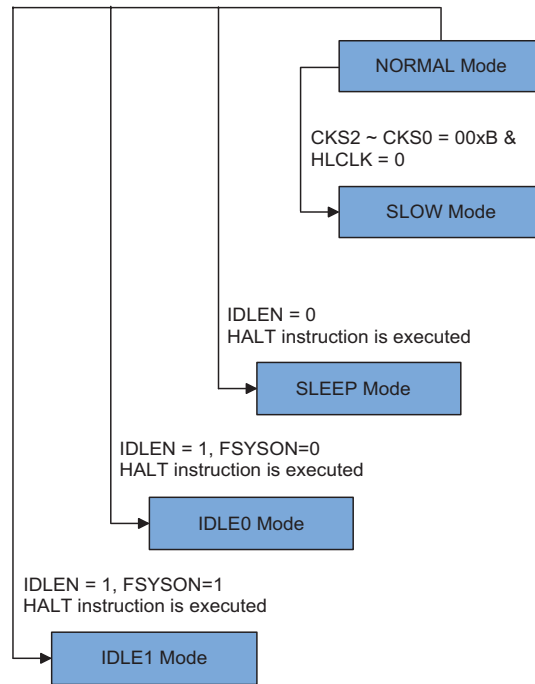

SLOW Mode to NORMAL Mode Switching

In SLOW Mode the system uses LIRC low speed system oscillator. To switch back to the NORMAL Mode, where the high speed system oscillator is used, the HLCLK bit should be set to “1” or HLCLK bit is “0”, but CKS2~CKS0 is set to “010”, “011”, “100”, “101”, “110” or “111”. As a certain amount of time will be required for the high frequency clock to stabilise, the status of the HTO bit is checked. The amount of time required for high speed system oscillator stabilization depends upon which high speed system oscillator type is used.

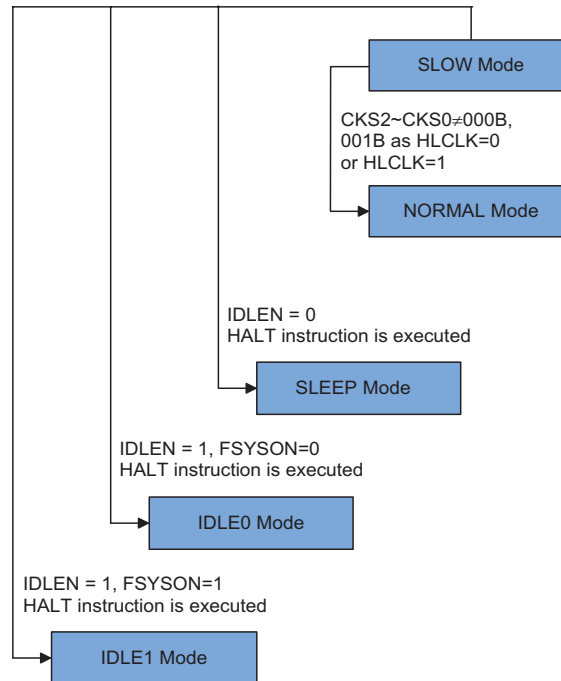

Entering the SLEEP Mode

There is only one way for the device to enter the SLEEP Mode and that is to execute the “HALT” instruction in the application program with the IDLEN bit in SMOD register equal to “0”. When this instruction is executed under the conditions described above, the following will occur:

- The system clock and Time Base clock will be stopped and the application program will stop at the “HALT” instruction.
- The Data Memory contents and registers will maintain their present condition.
- The WDT will be cleared and resume counting.
- The I/O ports will maintain their present conditions.
- In the status register, the Power Down flag, PDF, will be set and the Watchdog time-out flag, TO, will be cleared.

Entering the IDLE0 Mode

There is only one way for the device to enter the IDLE0 Mode and that is to execute the “HALT” instruction in the application program with the IDLEN bit in SMOD register equal to “1” and the FSYSON bit in CTRL register equal to “0”. When this instruction is executed under the conditions described above, the following will occur:

- The system clock will be stopped and the application program will stop at the “HALT” instruction, but the Time Base clock f_{TBC} and the low frequency f_{SUB} clock will be on.
- The Data Memory contents and registers will maintain their present condition.
- The WDT will be cleared and resume counting.
- The I/O ports will maintain their present conditions.
- In the status register, the Power Down flag, PDF, will be set and the Watchdog time-out flag, TO, will be cleared.

Entering the IDLE1 Mode

There is only one way for the device to enter the IDLE1 Mode and that is to execute the “HALT” instruction in the application program with the IDLEN bit in SMOD register equal to “1” and the FSYSON bit in CTRL register equal to “1”. When this instruction is executed under the conditions described above, the following will occur:

- The system clock and Time Base clock f_{TBC} and the low frequency f_{SUB} will be on and the application program will stop at the “HALT” instruction.
- The Data Memory contents and registers will maintain their present condition.
- The WDT will be cleared and resume counting.
- The I/O ports will maintain their present conditions.
- In the status register, the Power Down flag, PDF, will be set and the Watchdog time-out flag, TO, will be cleared.

Standby Current Considerations

As the main reason for entering the SLEEP or IDLE Mode is to keep the current consumption of the device to as low a value as possible, perhaps only in the order of several micro-amps except in the IDLE1 Mode, there are other considerations which must also be taken into account by the circuit designer if the power consumption is to be minimised. Special attention must be made to the I/O pins on the device. All high-impedance input pins must be connected to either a fixed high or low level as any floating input pins could create internal oscillations and result in increased current consumption. This also applies to devices which have different package types, as there may be unbonded pins. These must either be setup as outputs or if setup as inputs must have pull-high resistors connected.

Care must also be taken with the loads, which are connected to I/O pins, which are setup as outputs. These should be placed in a condition in which minimum current is drawn or connected only to external circuits that do not draw current, such as other CMOS inputs. In the IDLE1 Mode the system oscillator is on, if the system oscillator is from the high speed system oscillator, the additional standby current will also be perhaps in the order of several hundred micro-amps.

Wake-up

After the system enters the SLEEP or IDLE Mode, it can be woken up from one of various sources listed as follows:

- An external falling edge on Port A and an external raising edge on PB1, PB3
- A system interrupt
- A WDT overflow

If the device is woken up by a WDT overflow, a Watchdog Timer reset will be initiated. The actual source of the wake-up can be determined by examining the TO and PDF flags. The PDF flag is cleared by a system power-up or executing the clear Watchdog Timer instructions and is set when executing the “HALT” instruction. The TO flag is set if a WDT time-out occurs, and causes a wake-up that only resets the Program Counter and Stack Pointer, the other flags remain in their original status.

Each pin on Port A can be setup using the PAWU register to permit a negative transition on the pin, and PB1, PB3 also can be setup using the PBWU register to permit a positive transition on the pin to wake-up the system. When a Port A or PB1 or PB3 pin wake-up occurs, the program will resume execution at the instruction following the “HALT” instruction. If the system is woken up by an interrupt, then two possible situations may occur. The first is where the related interrupt is disabled or the interrupt is enabled but the stack is full, in which case the program will resume execution at the instruction following the “HALT” instruction. In this situation, the interrupt which woke-up the device will not be immediately serviced, but will rather be serviced later when the related interrupt is finally enabled or when a stack level becomes free. The other situation is where the related interrupt is enabled and the stack is not full, in which case the regular interrupt response takes place. If an interrupt request flag is set high before entering the SLEEP or IDLE Mode, the wake-up function of the related interrupt will be disabled.

Watchdog Timer

The Watchdog Timer is provided to prevent program malfunctions or sequences from jumping to unknown locations, due to certain uncontrollable external events such as electrical noise.

Watchdog Timer Clock Source

The Watchdog Timer clock source is provided by the internal f_{SUB} clock which is in turn supplied by the LIRC oscillator. The Watchdog Timer source clock is then subdivided by a ratio of 2^8 to 2^{18} to give longer timeouts, the actual value being chosen using the WS2~WS0 bits in the WDTC register. The LIRC internal oscillator has an approximate period of 32kHz at a supply voltage of 5V. However, it should be noted that this specified internal clock period can vary with V_{DD} , temperature and process variations.

Watchdog Timer Control Register

A single register, WDTC, controls the required timeout period as well as the enable operation. The WDTC register is initiated to 01010011B at any reset but keeps unchanged at the WDT time-out occurrence in a power down state.

WDTC Register

Bit	7	6	5	4	3	2	1	0
Name	WE4	WE3	WE2	WE1	WE0	WS2	WS1	WS0
R/W	R/W	R/W	R/W	R/W	R/W	R/W	R/W	R/W
POR	0	1	0	1	0	0	1	1

Bit 7~3 **WE4~WE0:** WDT function software control

10101 or 01010: Enabled
Other values: MCU Reset

When these bits are changed by the environmental noise to reset the microcontroller, the reset operation will be activated after 2~3 LIRC clock cycles and the WRF bit in the CTRL register will be set to 1.

Bit 2~0 **WS2~WS0:** WDT Time-out period selection

000: $2^8/f_s$
001: $2^{10}/f_s$
010: $2^{12}/f_s$
011: $2^{14}/f_s$
100: $2^{15}/f_s$
101: $2^{16}/f_s$
110: $2^{17}/f_s$
111: $2^{18}/f_s$

CTRL Register

Bit	7	6	5	4	3	2	1	0
Name	FSYSON	—	—	—	—	LVRF	LRF	WRF
R/W	R/W	—	—	—	—	R/W	R/W	R/W
POR	0	—	—	—	—	x	0	0

"x": unknown

Bit 7 **FSYSON**: f_{sys} Control IDLE Mode
Described elsewhere

Bit 6~3 Unimplemented, read as “0”

Bit 2 **LVRF**: Reset caused by LVR function activation
Described elsewhere

Bit 1 **LRF**: Reset caused by LVRC setting
Described elsewhere

Bit 0 **WRF**: Reset caused by WE[4:0] setting
0: Not occur
1: Occurred

This bit is set to 1 by the WDT Control register software reset and cleared by the application program. Note that this bit can only be cleared to 0 by the application program.

Watchdog Timer Operation

The Watchdog Timer operates by providing a device reset when its timer overflows. This means that in the application program and during normal operation the user has to strategically clear the Watchdog Timer before it overflows to prevent the Watchdog Timer from executing a reset. This is done using the clear watchdog instructions. If the program malfunctions for whatever reason, jumps to an unknown location, or enters an endless loop, the clear WDT instruction will not be executed in the correct manner, in which case the Watchdog Timer will overflow and reset the device. There are five bits, WE4~WE0, in the WDTC register to enable the WDT function. When the WE4~WE0 bits value is equal to 01010B or 10101B, the WDT function is enabled. However, if the WE4~WE0 bits are changed to any other values except 01010B and 10101B, which is caused by the environmental noise, it will reset the microcontroller after 2~3 LIRC clock cycles.

WE4~WE0 Bits	WDT Function
01010B or 10101B	Enable
Any other value	Reset MCU

Watchdog Timer Enable/Disable Control

Under normal program operation, a Watchdog Timer time-out will initialise a device reset and set the status bit TO. However, if the system is in the SLEEP or IDLE Mode, when a Watchdog Timer time-out occurs, the TO bit in the status register will be set and only the Program Counter and Stack Pointer will be reset. Three methods can be adopted to clear the contents of the Watchdog Timer. The first is a WDT reset, which means a certain value is written into the WE4~WE0 bit filed except 01010B and 10101B, the second is using the Watchdog Timer software clear instructions and the third is via a HALT instruction.

There is only one method of using software instruction to clear the Watchdog Timer. That is to use the single “CLR WDT” instruction to clear the WDT.

The maximum time-out period is when the 2¹⁸ division ratio is selected. As an example, with a 32kHz LIRC oscillator as its source clock, this will give a maximum watchdog period of around 8 seconds for the 2¹⁸ division ratio, and a minimum timeout of 7.8ms for the 2⁸ division ration.

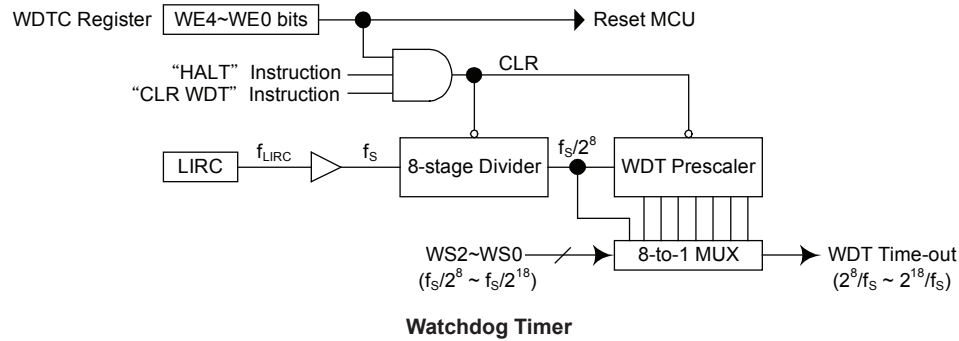

Reset and Initialisation

A reset function is a fundamental part of any microcontroller ensuring that the device can be set to some predetermined condition irrespective of outside parameters. The most important reset condition is after power is first applied to the microcontroller. In this case, internal circuitry will ensure that the microcontroller, after a short delay, will be in a well defined state and ready to execute the first program instruction. After this power-on reset, certain important internal registers will be set to defined states before the program commences. One of these registers is the Program Counter, which will be reset to zero forcing the microcontroller to begin program execution from the lowest Program Memory address.

Another type of reset is when the Watchdog Timer overflows and resets the microcontroller. All types of reset operations result in different register conditions being setup. Another reset exists in the form of a Low Voltage Reset, LVR, where a full reset is implemented in situations where the power supply voltage falls below a certain threshold.

Reset Functions

There are several ways in which a microcontroller reset can occur, through events occurring internally:

Power-on Reset

The most fundamental and unavoidable reset is the one that occurs after power is first applied to the microcontroller. As well as ensuring that the Program Memory begins execution from the first memory address, a power-on reset also ensures that certain other registers are preset to known conditions. All the I/O port and port control registers will power up in a high condition ensuring that all pins will be first set to inputs.

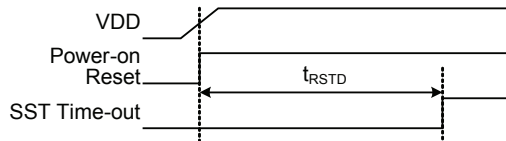

Note: t_{RSTD} is power-on delay, typical time=50ms

Power-On Reset Timing Chart

Low Voltage Reset – LVR

The microcontroller contains a low voltage reset circuit in order to monitor the supply voltage of the device. The LVR function is always enabled with a specific LVR voltage, V_{LVR} . If the supply voltage of the device drops to within a range of $0.9V \sim V_{LVR}$ such as might occur when changing the battery, the LVR will automatically reset the device internally and the LVRF bit in the CTRL register will also be set to 1. For a valid LVR signal, a low voltage, i.e., a voltage in the range between $0.9V \sim V_{LVR}$ must exist for greater than the value t_{LVR} specified in the A.C. characteristics. If the low voltage state does not exceed this value, the LVR will ignore the low supply voltage and will not perform a reset function. The actual V_{LVR} is fixed at a voltage value of 2.55V by the LVS bits in the LVRC register. If the LVS7~LVS0 bits are changed to some certain values by the environmental noise, the LVR will reset the device after 2~3 LIRC clock cycles. When this happens, the LRF bit in the CTRL register will be set to 1. After power on the register will have the value of 01010101B. Note that the LVR function will be automatically disabled when the device enters the power down mode.

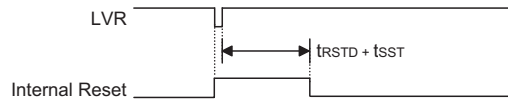

Note: t_{rSTD} is power-on delay, typical time=16.7ms

Low Voltage Reset Timing Chart

• LVRC Register

Bit	7	6	5	4	3	2	1	0
Name	LVS7	LVS6	LVS5	LVS4	LVS3	LVS2	LVS1	LVS0
R/W	R/W	R/W	R/W	R/W	R/W	R/W	R/W	R/W
POR	0	1	0	1	0	1	0	1

Bit 7~0 **LVS7~LVS0: LVR Voltage Select control**
 01010101: 2.55V
 00110011: 2.55V
 10011001: 2.55V
 10101010: 2.55V

Any other value: Generates MCU reset – register is reset to POR value

When an actual low voltage condition occurs, as specified by the above defined LVR voltage value, an MCU reset will be generated. The reset operation will be activated after 2~3 LIRC clock cycles. In this situation this register contents will remain the same after such a reset occurs.

Any register value, other than the four defined values above, will also result in the generation of an MCU reset. The reset operation will be activated after 2~3 LIRC clock cycles. However in this situation this register contents will be reset to the POR value.

• CTRL Register

Bit	7	6	5	4	3	2	1	0
Name	FSYSON	—	—	—	—	LVRF	LRF	WRF
R/W	R/W	—	—	—	—	R/W	R/W	R/W
POR	0	—	—	—	—	x	0	0

"x": unknown

- Bit 7 **FSYSON:** f_{sys} Control IDLE Mode
Described elsewhere
- Bit 6~3 Unimplemented, read as “0”
- Bit 2 **LVRF:** LVR function reset flag
0: Not occur
1: Occurred

This bit is set to 1 when a specific Low Voltage Reset situation condition occurs. This bit can only be cleared to 0 by the application program.
- Bit 1 **LRF:** LVR Control register software reset flag
0: Not occur
1: Occurred

This bit is set to 1 if the LVRC register contains any non defined LVR voltage register values. This in effect acts like a software reset function. This bit can only be cleared to 0 by the application program.
- Bit 0 **WRF:** WDT Control register software reset flag
Described elsewhere

Watchdog Time-out Reset during Normal Operation

The Watchdog time-out Reset during normal operation is the same as a LVR reset except that the Watchdog time-out flag TO will be set to “1”.

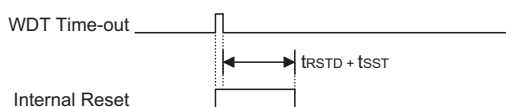

Note: tr_{STD} is power-on delay, typical time=16.7ms

WDT Time-out Reset during Normal Operation Timing Chart

Watchdog Time-out Reset during SLEEP or IDLE Mode

The Watchdog time-out Reset during SLEEP or IDLE Mode is a little different from other kinds of reset. Most of the conditions remain unchanged except that the Program Counter and the Stack Pointer will be cleared to “0” and the TO flag will be set to “1”. Refer to the A.C. Characteristics for ts_{ST} details.

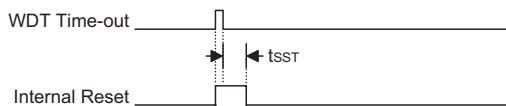

Note: The ts_{ST} is 15~16 clock cycles if the system clock source is provided by the HIRC.
The ts_{ST} is 1~2 clock for the LIRC.

WDT Time-out Reset during SLEEP or IDLE Timing Chart

Reset Initial Conditions

The different types of reset described affect the reset flags in different ways. These flags, known as PDF and TO are located in the status register and are controlled by various microcontroller operations, such as the SLEEP or IDLE Mode function or Watchdog Timer. The reset flags are shown in the table:

TO	PDF	RESET Conditions
0	0	Power-on reset
u	u	LVR reset during NORMAL or SLOW Mode operation
1	u	WDT time-out reset during NORMAL or SLOW Mode operation
1	1	WDT time-out reset during IDLE or SLEEP Mode operation

Note: “u” stands for unchanged

The following table indicates the way in which the various components of the microcontroller are affected after a power-on reset occurs.

Item	Condition After RESET
Program Counter	Reset to zero
Interrupts	All interrupts will be disabled
WDT	Clear after reset, WDT begins counting
Timer Modules	Timer Modules will be turned off
Input/Output Ports	I/O ports will be setup as inputs
Stack Pointer	Stack Pointer will point to the top of the stack

The different kinds of resets all affect the internal registers of the microcontroller in different ways. To ensure reliable continuation of normal program execution after a reset occurs, it is important to know what condition the microcontroller is in after a particular reset occurs. The following table describes how each type of reset affects each of the microcontroller internal registers.

Register	Reset (Power On)	WDT Time-out (Normal Operation)	WDT Time-out (HALT)
MP0	x x x x x x x x	x x x x x x x x	u u u u u u u u
MP1	x x x x x x x x	x x x x x x x x	u u u u u u u u
BP	- - - - - - 0	- - - - - - 0	- - - - - - u
ACC	x x x x x x x x	u u u u u u u u	u u u u u u u u
PCL	0 0 0 0 0 0 0 0	0 0 0 0 0 0 0 0	0 0 0 0 0 0 0 0
TBLP	x x x x x x x x	u u u u u u u u	u u u u u u u u
TBLH	x x x x x x x x	u u u u u u u u	u u u u u u u u
TBHP	- - - - - x x x	- - - - - u u u	- - - - - u u u
STATUS	- - 0 0 x x x x	- - 1 u u u u u	- - 1 1 u u u u
SMOD	1 1 0 - 0 0 1 0	1 1 0 - 0 0 1 0	u u u - u u u u
LVDC	- - 0 0 - 0 0 0	- - 0 0 - 0 0 0	- - u u - u u u
INTEG	- - - - 0 0 0 0	- - - - 0 0 0 0	- - - - u u u u
INTC0	- 0 0 0 0 0 0 0 0	- 0 0 0 0 0 0 0 0	- u u u u u u u
INTC1	0 0 0 0 0 0 0 0	0 0 0 0 0 0 0 0	u u u u u u u u
INTC2	- 0 0 0 - 0 0 0 0	- 0 0 0 - 0 0 0 0	- u u u - u u u
INTC3	- - 0 0 - - 0 0	- - 0 0 - - 0 0	- - u u - - u u
MF10	- - 0 0 - - 0 0	- - 0 0 - - 0 0	- - u u - - u u
MF11	- - 0 0 - - 0 0	- - 0 0 - - 0 0	- - u u - - u u
MF12	- 0 0 0 - 0 0 0 0	- 0 0 0 - 0 0 0 0	- u u u - u u u
PA	1 1 1 1 1 1 1 1	1 1 1 1 1 1 1 1	u u u u u u u u
PAC	1 1 1 1 1 1 1 1	1 1 1 1 1 1 1 1	u u u u u u u u

Register	Reset (Power On)	WDT Time-out (Normal Operation)	WDT Time-out (HALT)
PAPU	0000 0000	0000 0000	uuuu uuuu
PAWU	0000 0000	0000 0000	uuuu uuuu
TMPC	11-- ----	11-- ----	uu-- ----
WDTC	0101 0011	0101 0011	uuuu uuuu
TBC	0011 -111	0011 -111	uuuu -uuu
CPR	0--0 0000	0--0 0000	u--u uuuu
EEA	--00 0000	--00 0000	--uu uuuu
EED	0000 0000	0000 0000	uuuu uuuu
EEC	---- 0000	---- 0000	---- uuuu
ADRL (ADRF=0)	xxxx ----	xxxx ----	uuuu ----
ADRL (ADRF=1)	xxxx xxxx	xxxx xxxx	uuuu uuuu
ADRH (ADRF=0)	xxxx xxxx	xxxx xxxx	uuuu uuuu
ADRH (ADRF=1)	---- xxxx	---- xxxx	---- uuuu
ADCR0	0110 0000	0110 0000	uuuu uuuu
ADCR1	00-0 -000	00-0 -000	uu-u -uuu
CTRL	0--- -x00	0--- -000	u--- -uuu
LVRC	0101 0101	0101 0101	uuuu uuuu
TM0C0	0000 0000	0000 0000	uuuu uuuu
TM0C1	0000 0000	0000 0000	uuuu uuuu
TM0DL	0000 0000	0000 0000	uuuu uuuu
TM0DH	---- --00	---- --00	---- --uu
TM0AL	0000 0000	0000 0000	uuuu uuuu
TM0AH	---- --00	---- --00	---- --uu
TM1C0	0000 0---	0000 0---	uuuu u---
TM1C1	0000 0000	0000 0000	uuuu uuuu
TM1DL	0000 0000	0000 0000	uuuu uuuu
TM1DH	---- --00	---- --00	---- --uu
TM1AL	0000 0000	0000 0000	uuuu uuuu
TM1AH	---- --00	---- --00	---- --uu
TM1RPL	0000 0000	0000 0000	uuuu uuuu
TM1RPH	---- --00	---- --00	---- --uu
TM2C0	0000 0000	0000 0000	uuuu uuuu
TM2C1	0000 0000	0000 0000	uuuu uuuu
TM2DL	0000 0000	0000 0000	uuuu uuuu
TM2DH	---- --00	---- --00	---- --uu
TM2AL	0000 0000	0000 0000	uuuu uuuu
TM2AH	---- --00	---- --00	---- --uu
PB	-111 1111	-111 1111	-uuu uuuu
PBC	-111 1111	-111 1111	-uuu uuuu
PBPU	---- -0-0	---- -0-0	---- -u-u
PBPL	---- 0-0-	---- 0-0-	---- u-u-
PBWU	---- 0-0-	---- 0-0-	---- u-u-
PC	---- -000	---- -000	---- -uuu
PCC	---- -000	---- -000	---- -uuu
PCPU	---- -000	---- -000	---- -uuu
PAPS0	0000 0000	0000 0000	uuuu uuuu
PAPS1	0000 0000	0000 0000	uuuu uuuu

Register	Reset (Power On)	WDT Time-out (Normal Operation)	WDT Time-out (HALT)
PBPS	---0 0000	---0 0000	---u uuuu
PCPS	---- -000	---- -000	---- -uuu
OCPC	0000 0000	0000 0000	uuuu uuuu
OCP0C1	x000 0000	x000 0000	uuuu uuuu
OCP0DA	0000 0000	0000 0000	uuuu uuuu
A0CAL	0010 0000	0010 0000	uuuu uuuu
C0CAL	x001 0000	x001 0000	uuuu uuuu
OCP1C1	x000 0000	x000 0000	uuuu uuuu
OCP1DA	0000 0000	0000 0000	uuuu uuuu
A1CAL	0010 0000	0010 0000	uuuu uuuu
C1CAL	x001 0000	x001 0000	uuuu uuuu
OVPDA	0000 0000	0000 0000	uuuu uuuu
UVPDA	0000 0000	0000 0000	uuuu uuuu
OUVPC0	x--0 -000	x--0 -000	u--u -uuu
OUVPC1	x000 --00	x000 --00	uuuu --uu
OUVPC2	---- 0000	---- 0000	---- uuuu
ADJDT	--00 0000	--00 0000	--uu uuuu
ADJS	0000 0000	0000 0000	uuuu uuuu
ADJC	00-- xxxx	00-- xxxx	uu-- uuuu
ADJMaxH	---- --00	---- --00	---- --uu
ADJMaxL	0000 0000	0000 0000	uuuu uuuu
ADJMinH	---- --00	---- --00	---- --uu
ADJMinL	0000 0000	0000 0000	uuuu uuuu
ADJBH	---- --00	---- --00	---- --uu
ADJBL	0000 0000	0000 0000	uuuu uuuu
SWS	---0 0000	---0 0000	---u uuuu

Note: "-" stands for "unimplemented"

"u" stands for "unchanged"

"x" stands for "unknown"

Input/Output Ports

Holtek microcontrollers offer considerable flexibility on their I/O ports. With the input or output designation of every pin fully under user program control, pull-high selections, pull-low selections and wake-up selections on certain pins, the user is provided with an I/O structure to meet the needs of a wide range of application possibilities.

The device provides bidirectional input/output lines labeled with port names PA, PB and PC. These I/O ports are mapped to the RAM Data Memory with specific addresses as shown in the Special Purpose Data Memory table. All of these I/O ports can be used for input and output operations. For input operation, these ports are non-latching, which means the inputs must be ready at the T2 rising edge of instruction “MOV A, [m]”, where m denotes the port address. For output operation, all the data is latched and remains unchanged until the output latch is rewritten.

Register Name	Bit							
	7	6	5	4	3	2	1	0
PA	D7	D6	D5	D4	D3	D2	D1	D0
PAC	D7	D6	D5	D4	D3	D2	D1	D0
PAPU	D7	D6	D5	D4	D3	D2	D1	D0
PAWU	D7	D6	D5	D4	D3	D2	D1	D0
PB	—	D6	D5	D4	D3	D2	D1	D0
PBC	—	D6	D5	D4	D3	D2	D1	D0
PBPU	—	—	—	—	—	D2	—	D0
PBPL	—	—	—	—	PBPL3	—	PBPL1	—
PBWU	—	—	—	—	PBWU3	—	PBWU1	—
PC	—	—	—	—	—	D2	D1	D0
PCC	—	—	—	—	—	D2	D1	D0
PCPU	—	—	—	—	—	D2	D1	D0

I/O Control Register List

Pull-high and Pull-low Resistors

Many product applications require pull-high resistors or pull-low resistors for their switch inputs usually requiring the use of an external resistor. To eliminate the need for these external resistors, all I/O pins, when configured as an input have the capability of being connected to an internal pull-high resistor or an internal pull-low resistor. These pull-high resistors are selected using registers PAPU, PCPU, and are implemented using weak PMOS transistors. These pull-low resistors are only contained on PB port, and are implemented using NMOS transistors. If PB4 is configured as input, that pull-high resistor is always enabled. If PB5 or PB6 is configured as input, that pull-low resistor is always enabled.

PAPU Register

Bit	7	6	5	4	3	2	1	0
Name	D7	D6	D5	D4	D3	D2	D1	D0
R/W	R/W	R/W	R/W	R/W	R/W	R/W	R/W	R/W
POR	0	0	0	0	0	0	0	0

Bit 7~0 I/O Port A bit7 ~ bit 0 Pull-High Control
 0: Disable
 1: Enable

PBPU Register

Bit	7	6	5	4	3	2	1	0
Name	—	—	—	—	—	D2	—	D0
R/W	—	—	—	—	—	R/W	—	R/W
POR	—	—	—	—	—	0	—	0

- Bit 7~3 Unimplemented, read as “0”
- Bit 2 I/O Port B bit 2 Pull-High Control
0: Disable
1: Enable
- Bit 1 Unimplemented, read as “0”
- Bit 0 I/O Port B bit 0 Pull-High Control
0: Disable
1: Enable

PCPU Register

Bit	7	6	5	4	3	2	1	0
Name	—	—	—	—	—	D2	D1	D0
R/W	—	—	—	—	—	R/W	R/W	R/W
POR	—	—	—	—	—	0	0	0

- Bit 7~3 Unimplemented, read as “0”
- Bit 2~0 I/O Port B bit 2~bit 0 Pull-High Control
0: Disable
1: Enable

PBPL Register

Bit	7	6	5	4	3	2	1	0
Name	—	—	—	—	PBPL3	—	PBPL1	—
R/W	—	—	—	—	R/W	—	R/W	—
POR	—	—	—	—	0	—	0	—

- Bit 7~4 Unimplemented, read as “0”
- Bit 3 I/O Port B bit 3 Pull-low Control
0: Disable
1: Enable
- Bit 2 Unimplemented, read as “0”
- Bit 1 I/O Port B bit 1 Pull-low Control
0: Disable
1: Enable
- Bit 0 Unimplemented, read as “0”

Port A and Port B Wake-up

The HALT instruction forces the microcontroller into the SLEEP or IDLE Mode which preserves power, a feature that is important for battery and other low-power applications. Various methods exist to wake-up the microcontroller, one of which is to change the logic condition on one of the Port A pins from high to low or Port B from low to high. This function is especially suitable for applications that can be woken up via external switches. Each pin on Port A or PB1 or PB3 can be selected individually to have this wake-up feature using the PAWU or PBWU register.

PAWU Register

Bit	7	6	5	4	3	2	1	0
Name	D7	D6	D5	D4	D3	D2	D1	D0
R/W	R/W	R/W	R/W	R/W	R/W	R/W	R/W	R/W
POR	0	0	0	0	0	0	0	0

Bit 7~0 I/O Port A bit 7 ~ bit 0 Wake Up Control

0: Disable

1: Enable

PBWU Register

Bit	7	6	5	4	3	2	1	0
Name	—	—	—	—	PBWU3	—	PBWU1	—
R/W	—	—	—	—	R/W	—	R/W	—
POR	—	—	—	—	0	—	0	—

Bit 7~4 Unimplemented, read as “0”

Bit 3 I/O Port B bit 3 Wake-up Control

0: Disable

1: Enable

Bit 2 Unimplemented, read as “0”

Bit 1 I/O Port B bit 1 Wake-up Control

0: Disable

1: Enable

Bit 0 Unimplemented, read as “0”

I/O Port Control Registers

Each I/O port has its own control register known as PAC~PCC, to control the input/output configuration. With this control register, each CMOS output or input can be reconfigured dynamically under software control. Each pin of the I/O ports is directly mapped to a bit in its associated port control register. For the I/O pin to function as an input, the corresponding bit of the control register must be written as a “1”. This will then allow the logic state of the input pin to be directly read by instructions. When the corresponding bit of the control register is written as a “0”, the I/O pin will be setup as a CMOS output. If the pin is currently setup as an output, instructions can still be used to read the output register. However, it should be noted that the program will in fact only read the status of the output data latch and not the actual logic status of the output pin.

PAC Register

Bit	7	6	5	4	3	2	1	0
Name	D7	D6	D5	D4	D3	D2	D1	D0
R/W	R/W	R/W	R/W	R/W	R/W	R/W	R/W	R/W
POR	1	1	1	1	1	1	1	1

Bit 7~0 I/O Port A bit 7 ~ bit 0 Input/Output Control

0: Output

1: Input

PBC Register

Bit	7	6	5	4	3	2	1	0
Name	—	D6	D5	D4	D3	D2	D1	D0
R/W	—	R/W	R/W	R/W	R/W	R/W	R/W	R/W
POR	—	1	1	1	1	1	1	1

- Bit 7 Unimplemented, read as “0”
- Bit 6~0 I/O Port B bit 6 ~ bit 0 Input/Output Control
0: Output
1: Input

PCC Register

Bit	7	6	5	4	3	2	1	0
Name	—	—	—	—	—	D2	D1	D0
R/W	—	—	—	—	—	R/W	R/W	R/W
POR	—	—	—	—	—	1	1	1

- Bit 7~3 Unimplemented, read as “0”
- Bit 2~0 I/O Port B bit 2 ~ bit 0 Input/Output Control
0: Output
1: Input

Pin-shared Functions

The flexibility of the microcontroller range is greatly enhanced by the use of pins that have more than one function. Limited number of pins can force serious design constraints on designers but by supplying pins with multi-functions, many of these difficulties can be overcome. For some pins, the chosen function of the multi-function I/O pins is set by application program control.

PAPS0 Register

Bit	7	6	5	4	3	2	1	0
Name	PA3S1	PA3S0	PA2S1	PA2S0	PA1S1	PA1S0	PA0S1	PA0S0
R/W	R/W	R/W	R/W	R/W	R/W	R/W	R/W	R/W
POR	0	0	0	0	0	0	0	0

- Bit 7~6 **PA3S1~PA3S0**: PA3 Pin Share Setting
00: PA3
01: AN3
10: OCP0
11: OCP1
- Bit 5~4 **PA2S1~PA2S0**: PA2 Pin Share Setting
00: PA2
01: BATV/AN2
10: PA2
11: PA2
- Bit 3~2 **PA1S1~PA1S0**: PA1 Pin Share Setting
00: PA1
01: PA1
10: VREF- It can be used as DAC of the OCP0/OCP1/OUVP or ADC reference voltage
11: PA1
- Bit 1~0 **PA0S1~PA0S0**: PA0 Pin Share Setting
00: PA0
01: OUVP/AN0
10: PA0
11: PA0

PAPS1 Register

Bit	7	6	5	4	3	2	1	0
Name	PA7S1	PA7S0	PA6S1	PA6S0	PA5S1	PA5S0	PA4S1	PA4S0
R/W	R/W	R/W	R/W	R/W	R/W	R/W	R/W	R/W
POR	0	0	0	0	0	0	0	0

- Bit 7~6 **PA7S1~PA7S0:** PA7 Pin Share Setting
 00: PA7/INT0
 01: TP0_1
 10: PA7/INT0
 11: PA7/INT0
- Bit 5~4 **PA6S1~PA6S0:** PA6 Pin Share Setting
 00: PA6/INT1
 01: AN6
 10: PA6/INT1
 11: PA6/INT1
- Bit 3~2 **PA5S1~PA5S0:** PA5 Pin Share Setting
 00: PA5
 01: PA5
 10: OCP0
 11: OCP1
- Bit 1~0 **PA4S1~PA4S0:** PA4 Pin Share Setting
 00: PA4
 01: AN4
 10: OCP0
 11: OCP1

PBPS Register

Bit	7	6	5	4	3	2	1	0
Name	—	—	—	PB5S	PB4S	PB3S	PB2S	PB0S
R/W	—	—	—	R/W	R/W	R/W	R/W	R/W
POR	—	—	—	0	0	0	0	0

- Bit 7~5 Unimplemented, read as “0”
- Bit 4 **PB5S:** PB5 Pin Share Setting
 0: PB5
 1: OUTL
- Bit 3 **PB4S:** PB4 Pin Share Setting
 0: PB4
 1: OUTH
- Bit 2 **PB3S:** PB3 Pin Share Setting
 0: PB3
 1: TP1_0
- Bit 1 **PB2S:** PB2 Pin Share Setting
 0: PB2
 1: TP1_1
- Bit 0 **PB0S:** PB0 Pin Share Setting
 0: PB0
 1: TP2_0

PCPS Register

Bit	7	6	5	4	3	2	1	0
Name	—	—	—	—	—	PC2S1	PC2S0	PC0S
R/W	—	—	—	—	—	R/W	R/W	R/W
POR	—	—	—	—	—	0	0	0

- Bit 7~3 Unimplemented, read as “0”
- Bit 2~1 **PC2S1~PC2S0**: PC2 Pin Share Setting
 - 00: PC2
 - 01: TP0_0
 - 10: AN7
 - 11: PC2
- Bit 0 **PC0S**: PC0 Pin Share Setting
 - 0: PC0
 - 1: TP2_1

TMPC Register

Bit	7	6	5	4	3	2	1	0
Name	OUTHN	OUTLN	—	—	—	—	—	—
R/W	R/W	R/W	—	—	—	—	—	—
POR	1	1	—	—	—	—	—	—

- Bit 7 **OUTHN**: OUTH is inveter or not before output
 - 0: non-inveter
 - 1: inveter
- Bit 6 **OUTLN**: OUTL is inveter or not before output
 - 0: non-inveter
 - 1: inveter
- Bit 5~0 Unimplemented, read as “0”

I/O Pin Structures

The accompanying diagrams illustrate the internal structures of some generic I/O pin types. As the exact logical construction of the I/O pin will differ from these drawings, they are supplied as a guide only to assist with the functional understanding of the I/O pins. The wide range of pin-shared structures does not permit all types to be shown.

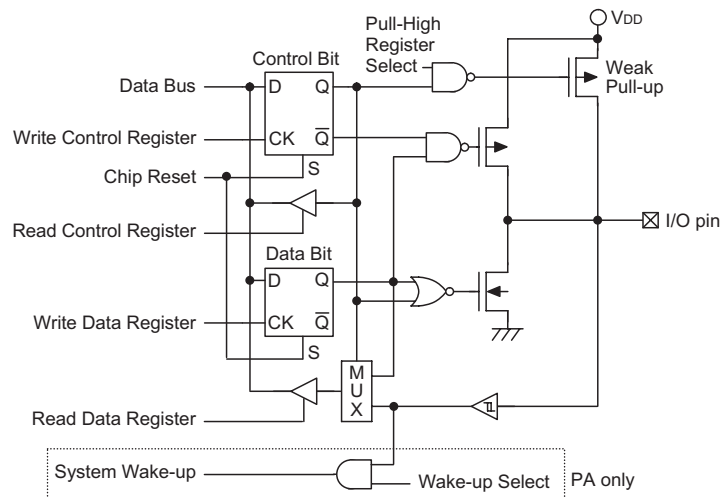

Note: If PB4 configured as input, that pull-high is always enabled.

PA/PC/PB0/PB2/PB4 Input/Output Structure

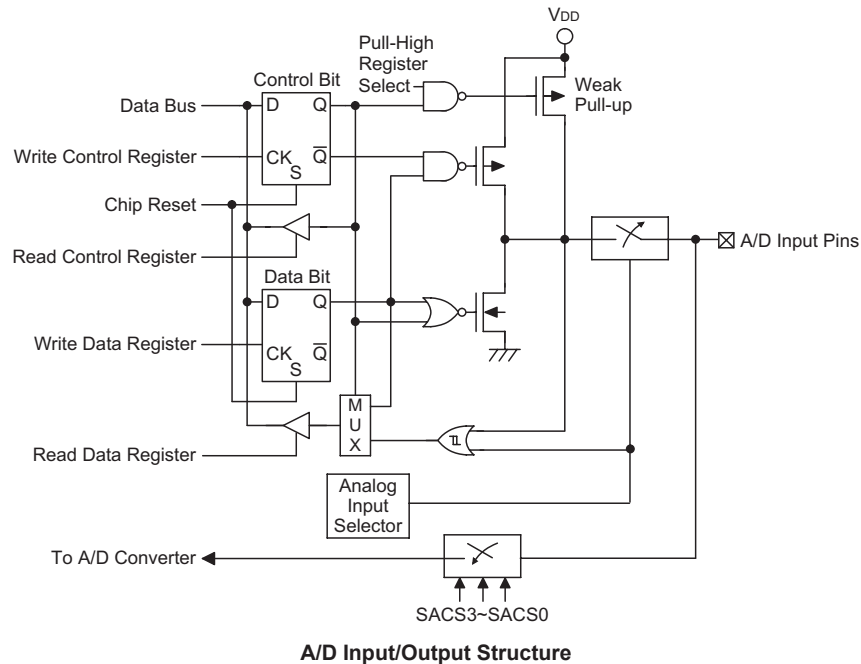

Programming Considerations

Within the user program, one of the first things to consider is port initialisation. After a reset, all of the I/O data and port control registers will be set high. This means that all I/O pins will default to an input state, the level of which depends on the other connected circuitry and whether pull-high selections have been chosen. If the port control registers, PAC~PCC, are then programmed to setup some pins as outputs, these output pins will have an initial high output value unless the associated port data registers, PA~PC, are first programmed. Selecting which pins are inputs and which are outputs can be achieved byte-wide by loading the correct values into the appropriate port control register or by programming individual bits in the port control register using the “SET [m].i” and “CLR [m].i” instructions. Note that when using these bit control instructions, a read-modify-write operation takes place. The microcontroller must first read in the data on the entire port, modify it to the required new bit values and then rewrite this data back to the output ports.

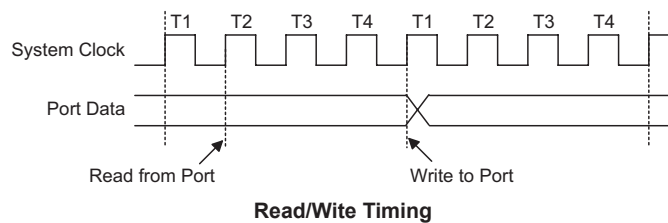

Port A and certain PB pins have the additional capability of providing wake-up functions. When the device is in the SLEEP or IDLE Mode, various methods are available to wake the device up. One of these is a high to low transition of any of the Port A pins or a low to high transition of PB1 and PB3. Single or multiple pins on Port A or PB1 or PB3 can be setup to have this function.

Timer Modules – TM

One of the most fundamental functions in any microcontroller device is the ability to control and measure time. To implement time related functions the device includes several Timer Modules, abbreviated to the name TM. The TMs are multi-purpose timing units and serve to provide operations such as Timer/Counter, Input Capture, Compare Match Output and Single Pulse Output as well as being the functional unit for the generation of PWM signals. Each of the TMs has two individual interrupts. The addition of input and output pins for each TM ensures that users are provided with timing units with a wide and flexible range of features.

The common features of the different TM types are described here with more detailed information provided in the individual Compact, Standard and Periodic TM section.

Introduction

The device contains a 10-bit Standard TM, a 10-bit Periodic TM and a 10-bit Compact TM, each TM having a reference name of TM0, TM1 and TM2. Although similar in nature, the different TM types vary in their feature complexity. The common features to the Compact, Standard and Periodic TMs will be described in this section and the detailed operation will be described in corresponding sections. The main features and differences between the three types of TMs are summarised in the accompanying table.

Function	STM	PTM	CTM
Timer/Counter	√	√	√
I/P Capture	√	√	—
Compare Match Output	√	√	√
PWM Channels	1	1	1
Single Pulse Output	1	1	—
PWM Alignment	Edge	Edge	Edge
PWM Adjustment Period & Duty	Duty or Period	Duty or Period	Duty or Period

TM Function Summary

TM0	TM1	TM2
10-bit STM	10-bit PTM	10-bit CTM

TM Name/Type Reference

TM Operation

The three different types of TMs offer a diverse range of functions, from simple timing operations to PWM signal generation. The key to understanding how the TM operates is to see it in terms of a free running counter whose value is then compared with the value of pre-programmed internal comparators. When the free running counter has the same value as the pre-programmed comparator, known as a compare match situation, a TM interrupt signal will be generated which can clear the counter and perhaps also change the condition of the TM output pin. The internal TM counter is driven by a user selectable clock source, which can be an internal clock or an external pin.

TM Clock Source

The clock source which drives the main counter in each TM can originate from various sources. The selection of the required clock source is implemented using the TnCK2~TnCK0 bits in the TM control registers. The clock source can be a ratio of either the system clock f_{SYS} or the internal high clock f_{IH} , the f_{TBC} clock source or the external TCKn pin. The TCKn pin clock source is used to allow an external signal to drive the TM as an external clock source or for event counting.

TM Interrupts

The three different types of TMs each have two internal interrupts, the internal comparator A or comparator P, which generate a TM interrupt when a compare match condition occurs. When a TM interrupt is generated, it can be used to clear the counter and also to change the state of the TM output pin.

TM External Pins

Each of the TMs, irrespective of what type, has one TM input pin, with the label TCKn. The TM input pin, is essentially a clock source for the TM and is selected using the TnCK2~TnCK0 bits in the TMnC0 register. This external TM input pin allows an external clock source to drive the internal TM. This external TM input pin is shared with other functions but will be connected to the internal TM if selected using the TnCK2~TnCK0 bits. The TM input pin can be chosen to have either a rising or falling active edge.

The TMs each have two output pins. When the TM is in the Compare Match Output Mode, these pins can be controlled by the TM to switch to a high or low level or to toggle when a compare match situation occurs. The external TPn output pin is also the pin where the TM generates the PWM output waveform. As the TM output pins are pin-shared with other function, the TM output function must first be setup using registers. A single bit in one of the registers determines if its associated pin is to be used as an external TM output pin or if it is to have another function. The number of output pins for each TM type is different, the details are provided in the accompanying table.

TM output pin names have an “_n” suffix. Pin names that include a “_0” or “_1” suffix indicate that they are from a TM with multiple output pins. This allows the TM to generate a complimentary output pair, selected using the I/O register data bits.

TM0	TM1	TM2
TP0_0, TP0_1	TP1_0, TP1_1	TP2_0, TP2_1

TM Output Pins

Programming Considerations

The TM Counter Registers, the Capture/Compare CCRA and the TM1 CCRP registers, being both 10-bit, all have a low and high byte structure. The high bytes can be directly accessed, but as the low bytes can only be accessed via an internal 8-bit buffer, reading or writing to these register pairs must be carried out in a specific way. The important point to note is that data transfer to and from the 8-bit buffer and its related low byte only takes place when a write or read operation to its corresponding high byte is executed. As the CCRA and CCRP registers are implemented in the way shown in the following diagram and accessing these register pairs is carried out in a specific way described above, it is recommended to use the “MOV” instruction to access the CCRA or CCRP low byte registers, named TMxAL or TMxRPL, using the following access procedures. Accessing the CCRA or CCRP low byte register without following these access procedures will result in unpredictable values.

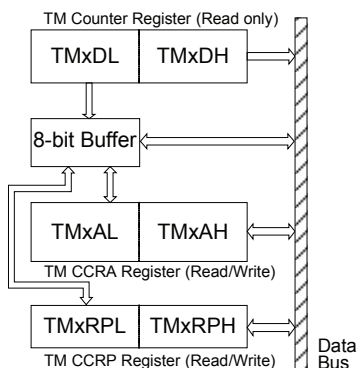

The following steps show the read and write procedures:

- Writing Data to CCRA or CCRP
 - ♦ Step 1. Write data to Low Byte TMxAL or TMxRPL
 - note that here data is only written to the 8-bit buffer.
 - ♦ Step 2. Write data to High Byte TMxAH or TMxRPH
 - here data is written directly to the high byte registers and simultaneously data is latched from the 8-bit buffer to the Low Byte registers.
- Reading Data from the Counter Registers and CCRA or CCRP
 - ♦ Step 1. Read data from the High Byte TMxDH, TMxAH or TMxRPH
 - here data is read directly from the High Byte registers and simultaneously data is latched from the Low Byte register into the 8-bit buffer.
 - ♦ Step 2. Read data from the Low Byte TMxDL, TMxAL or TMxRPL
 - this step reads data from the 8-bit buffer.

Standard Type TM – STM

The Standard Type TM contains five operating modes, which are Compare Match Output, Timer/Event Counter, Capture Input, Single Pulse Output and PWM Output modes. The Standard TM can also be controlled with an external input pin and can drive two external output pins. These two external output pins can be the same signal or the inverse signal.

Name	TM No.	TM Input Pin	TM Output Pin
10-bit STM	0	TCK0	TP0_0, TP0_1

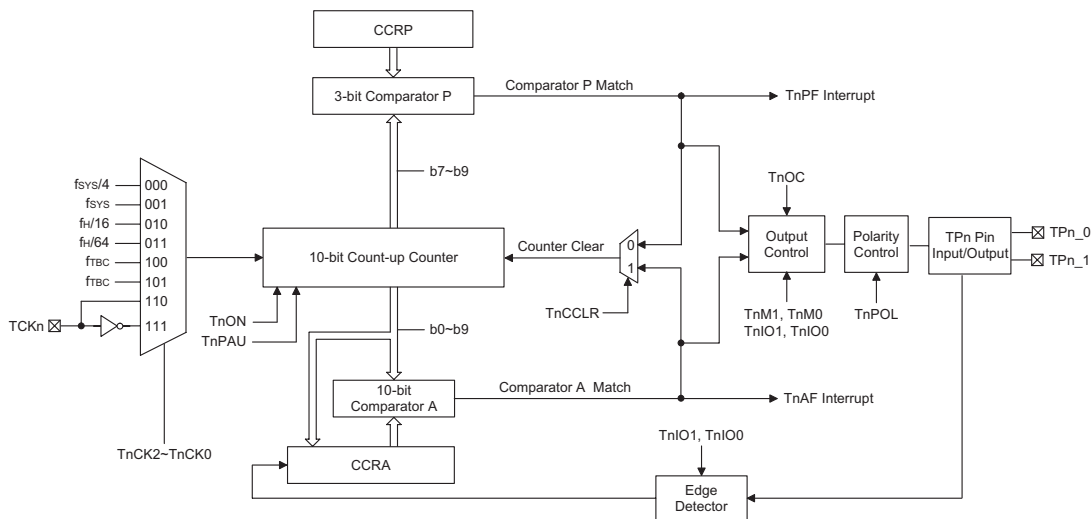

Standard Type TM Block Diagram (n=0)

Standard TM Operation

At its core is a 10-bit count-up counter which is driven by a user selectable internal or external clock source. There are also two internal comparators with the names, Comparator A and Comparator P. These comparators will compare the value in the counter with CCRP and CCRA registers. The CCRP is 3-bits wide whose value is compared with the highest 3 bits in the counter while the CCRA is the 10 bits and therefore compares with all counter bits.

The only way of changing the value of the 10-bit counter using the application program, is to clear the counter by changing the T0ON bit from low to high. The counter will also be cleared automatically by a counter overflow or a compare match with one of its associated comparators. When these conditions occur, a TM interrupt signal will also usually be generated. The Standard Type TM can operate in a number of different operational modes, can be driven by different clock sources including an input pin and can also control two output pins. All operating setup conditions are selected using relevant internal registers.

Standard Type TM Register Description

Overall operation of the Standard TM is controlled using six registers. A read only register pair exists to store the internal counter 10-bit value, while a read/write register pair exists to store the internal 10-bit CCRA value. The remaining two registers are control registers which setup the different operating and control modes as well as three CCRP bits.

Register Name	Bit							
	7	6	5	4	3	2	1	0
TM0C0	T0PAU	T0CK2	T0CK1	T0CK0	T0ON	T0RP2	T0RP1	T0RP0
TM0C1	T0M1	T0M0	T0IO1	T0IO0	T0OC	T0POL	T0DPX	T0CCLR
TM0DL	D7	D6	D5	D4	D3	D2	D1	D0
TM0DH	—	—	—	—	—	—	D9	D8
TM0AL	D7	D6	D5	D4	D3	D2	D1	D0
TM0AH	—	—	—	—	—	—	D9	D8

10-bit Standard TM Register List

TM0C0 Register

Bit	7	6	5	4	3	2	1	0
Name	T0PAU	T0CK2	T0CK1	T0CK0	T0ON	T0RP2	T0RP1	T0RP0
R/W	R/W	R/W	R/W	R/W	R/W	R/W	R/W	R/W
POR	0	0	0	0	0	0	0	0

Bit 7 **T0PAU: TM0 Counter Pause Control**

0: Run
1: Pause

The counter can be paused by setting this bit high. Clearing the bit to zero restores normal counter operation. When in a Pause condition the TM will remain powered up and continue to consume power. The counter will retain its residual value when this bit changes from low to high and resume counting from this value when the bit changes to a low value again.

Bit 6~4 **T0CK2~T0CK0: Select TM0 Counter clock**

000: $f_{SYS}/4$
001: f_{SYS}
010: $f_H/16$
011: $f_H/64$
100: f_{TBC}
101: f_{TBC}
110: TCK0 rising edge clock
111: TCK0 falling edge clock

These three bits are used to select the clock source for the TM. The external pin clock source can be chosen to be active on the rising or falling edge. The clock source f_{SYS} is the system clock, while f_H and f_{TBC} are other internal clocks, the details of which can be found in the oscillator section.

Bit 3 **T0ON: TM0 Counter On/Off Control**

0: Off
1: On

This bit controls the overall on/off function of the TM. Setting the bit high enables the counter to run, clearing the bit disables the TM. Clearing this bit to zero will stop the counter from counting and turn off the TM which will reduce its power consumption. When the bit changes state from low to high the internal counter value will be reset to zero, however when the bit changes from high to low, the internal counter will retain its residual value until the bit returns high again.

If the TM is in the Compare Match Output Mode then the TM output pin will be reset to its initial condition, as specified by the T0OC bit, when the T0ON bit changes from low to high.

- Bit 2~0 TM0 CCRP 3-bit register, compared with the TM0 Counter bit 9~bit 7
- Comparator P Match Period
- 000: 1024 TM0 clocks
 - 001: 128 TM0 clocks
 - 010: 256 TM0 clocks
 - 011: 384 TM0 clocks
 - 100: 512 TM0 clocks
 - 101: 640 TM0 clocks
 - 110: 768 TM0 clocks
 - 111: 896 TM0 clocks

TM0C1 Register

Bit	7	6	5	4	3	2	1	0
Name	T0M1	T0M0	T0IO1	T0IO0	T0OC	T0POL	T0DPX	T0CCLR
R/W	R/W	R/W	R/W	R/W	R/W	R/W	R/W	R/W
POR	0	0	0	0	0	0	0	0

- Bit 7~6 **T0M1~T0M0:** Select TM0 Operating Mode
- 00: Compare Match Output Mode
 - 01: Capture Input Mode
 - 10: PWM Mode or Single Pulse Output Mode
 - 11: Timer/Counter Mode

These bits setup the required operating mode for the TM. To ensure reliable operation the TM should be switched off before any changes are made to the bits. In the Timer/Counter Mode, the TM output pin control must be disabled.

- Bit 5~4 **T0IO1~T0IO0:** Select TM0 output function

Compare Match Output Mode

- 00: No change
- 01: Output low
- 10: Output high
- 11: Toggle output

PWM Mode/Single Pulse Output Mode

- 00: Force inactive state
- 01: Force active state
- 10: PWM output
- 11: Single pulse output

Capture Input Mode

- 00: Input capture at rising edge of TM capture input pin
- 01: Input capture at falling edge of TM capture input pin
- 10: Input capture at falling/rising edge of TM capture input pin
- 11: Input capture disabled

Timer/counter Mode

Unused

These two bits are used to determine how the TM output pin changes state when a certain condition is reached. The function that these bits select depends upon in which mode the TM is running.

In the Compare Match Output Mode, the T0IO1~T0IO0 bits determine how the TM output pin changes state when a compare match occurs from the Comparator A. The TM output pin can be setup to switch high, switch low or to toggle its present state when a compare match occurs from the Comparator A. When the T0IO1~T0IO0 bits are both zero, then no change will take place on the output. The initial value of the TM output pin should be setup using the T0OC bit. Note that the output level requested by the T0IO1~T0IO0 bits must be different from the initial value setup using the T0OC

bit otherwise no change will occur on the TM output pin when a compare match occurs. After the TM output pin changes state it can be reset to its initial level by changing the level of the T0ON bit from low to high.

In the PWM Mode, the T0IO1 and T0IO0 bits determine how the TM output pin changes state when a certain compare match condition occurs. The PWM output function is modified by changing these two bits. It is necessary to change the values of the T0IO1 and T0IO0 bits only after the TM has been switched off. Unpredictable PWM outputs will occur if the T0IO1 and T0IO0 bits are changed when the TM is running.

Bit 3 **T0OC:** TM0 Output control bit

Compare Match Output Mode

0: Initial low

1: Initial high

PWM Mode/Single Pulse Output Mode

0: Active low

1: Active high

This is the output control bit for the TM output pin. Its operation depends upon whether TM is being used in the Compare Match Output Mode or in the PWM Mode/Single Pulse Output Mode. It has no effect if the TM is in the Timer/Counter Mode. In the Compare Match Output Mode it determines the logic level of the TM output pin before a compare match occurs. In the PWM Mode it determines if the PWM signal is active high or active low.

Bit 2 **T0POL:** TM0 Output polarity Control

0: Non-invert

1: Invert

This bit controls the polarity of the TM output pin. When the bit is set high the TM output pin will be inverted and not inverted when the bit is zero. It has no effect if the TM is in the Timer/Counter Mode.

Bit 1 **T0DPX:** TM0 PWM period/duty Control

0: CCRP - period; CCRA - duty

1: CCRP - duty; CCRA - period

This bit, determines which of the CCRA and CCRP registers are used for period and duty control of the PWM waveform.

Bit 0 **T0CCLR:** Select TM0 Counter clear condition

0: TM Comparatror P match

1: TM Comparatror A match

This bit is used to select the method which clears the counter. Remember that the Standard TM contains two comparators, Comparator A and Comparator P, either of which can be selected to clear the internal counter. With the T0CCLR bit set high, the counter will be cleared when a compare match occurs from the Comparator A. When the bit is low, the counter will be cleared when a compare match occurs from the Comparator P or with a counter overflow. A counter overflow clearing method can only be implemented if the CCRP bits are all cleared to zero. The T0CCLR bit is not used in the PWM, Single Pulse or Input Capture Mode.

TM0DL Register

Bit	7	6	5	4	3	2	1	0
Name	D7	D6	D5	D4	D3	D2	D1	D0
R/W	R	R	R	R	R	R	R	R
POR	0	0	0	0	0	0	0	0

Bit 7~0 **TM0DL**: TM0 Counter Low Byte Register bit 7 ~ bit 0
TM 10-bit Counter bit 7 ~ bit 0

TM0DH Register

Bit	7	6	5	4	3	2	1	0
Name	—	—	—	—	—	—	D9	D8
R/W	—	—	—	—	—	—	R	R
POR	—	—	—	—	—	—	0	0

Bit 2~0 **TM0DH**: TM0 Counter High Byte Register bit 1 ~ bit 0
TM 10-bit Counter bit 9 ~ bit 8

TM0AL Register

Bit	7	6	5	4	3	2	1	0
Name	D7	D6	D5	D4	D3	D2	D1	D0
R/W	R/W	R/W	R/W	R/W	R/W	R/W	R/W	R/W
POR	0	0	0	0	0	0	0	0

Bit 7~0 **TM0AL**: TM0 CCRA Low Byte Register bit 7 ~ bit 0
TM 10-bit CCRA bit 7 ~ bit 0

TM0AH Register

Bit	7	6	5	4	3	2	1	0
Name	—	—	—	—	—	—	D9	D8
R/W	—	—	—	—	—	—	R/W	R/W
POR	—	—	—	—	—	—	0	0

Bit 2~0 **TM0AH**: TM0 CCRA High Byte Register bit 1 ~ bit 0
TM 10-bit CCRA bit 9 ~ bit 8

Standard Type TM Operating Modes

The Standard Type TM can operate in one of five operating modes, Compare Match Output Mode, PWM Output Mode, Single Pulse Output Mode, Capture Input Mode or Timer/Counter Mode. The operating mode is selected using the TOM1 and TOM0 bits in the TM0C1 register.

Compare Output Mode

To select this mode, bits TOM1 and TOM0 in the TM0C1 register, should be set to 00 respectively. In this mode once the counter is enabled and running it can be cleared by three methods. These are a counter overflow, a compare match from Comparator A and a compare match from Comparator P. When the TOCCLR bit is low, there are two ways in which the counter can be cleared. One is when a compare match from Comparator P, the other is when the CCRP bits are all zero which allows the counter to overflow. Here both T0AF and T0PF interrupt request flags for Comparator A and Comparator P respectively, will both be generated.

If the TOCCLR bit in the TM0C1 register is high then the counter will be cleared when a compare match occurs from Comparator A. However, here only the T0AF interrupt request flag will be generated even if the value of the CCRP bits is less than that of the CCRA registers. Therefore when TOCCLR is high no T0PF interrupt request flag will be generated. In the Compare Match Output Mode, the CCRA can not be set to “0”.

As the name of the mode suggests, after a comparison is made, the TM output pin, will change state. The TM output pin condition however only changes state when a T0AF interrupt request flag is generated after a compare match occurs from Comparator A. The T0PF interrupt request flag, generated from a compare match occurs from Comparator P, will have no effect on the TM output pin. The way in which the TM output pin changes state are determined by the condition of the T0IO1 and T0IO0 bits in the TM0C1 register. The TM output pin can be selected using the T0IO1 and T0IO0 bits to go high, to go low or to toggle from its present condition when a compare match occurs from Comparator A. The initial condition of the TM output pin, which is setup after the T0ON bit changes from low to high, is setup using the T0OC bit. Note that if the T0IO1 and T0IO0 bits are zero then no pin change will take place.

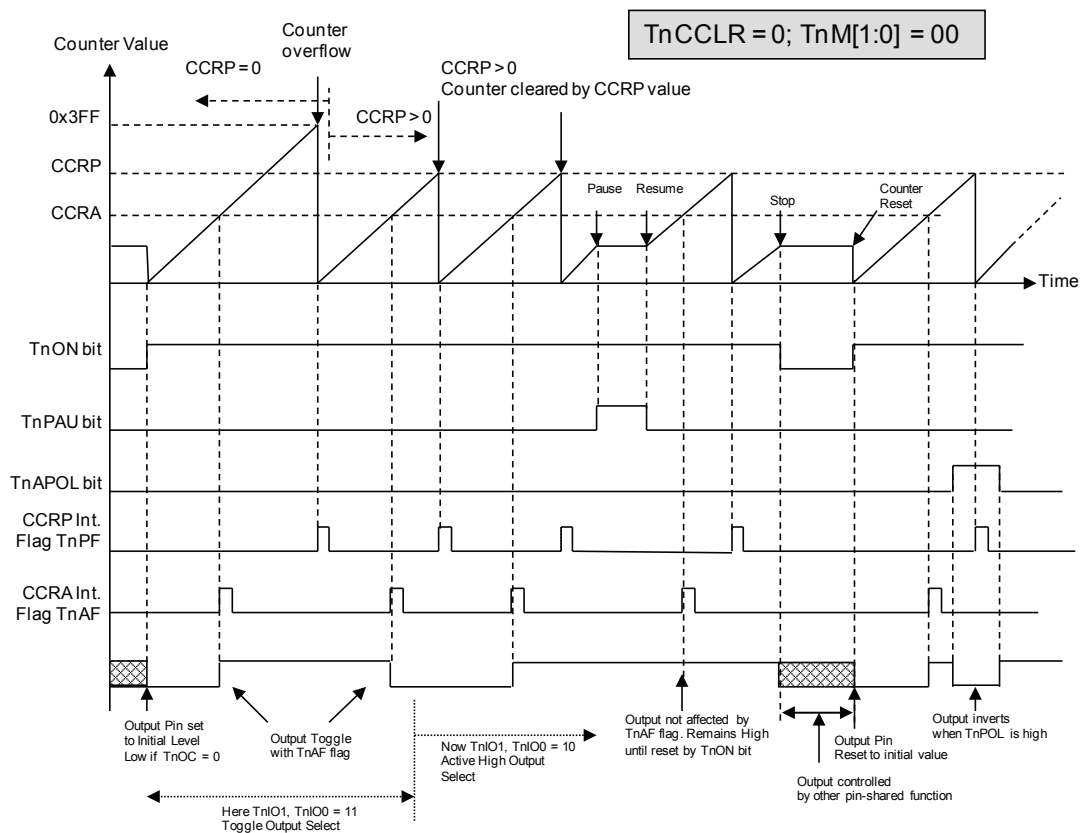

Compare Match Output Mode – TnCCLR=0

- Note: 1. With TnCCLR = 0 a Comparator P match will clear the counter
 2. The TM output pin controlled only by the TnAF flag
 3. The output pin reset to initial state by a TnON bit rising edge
 4. n = 0

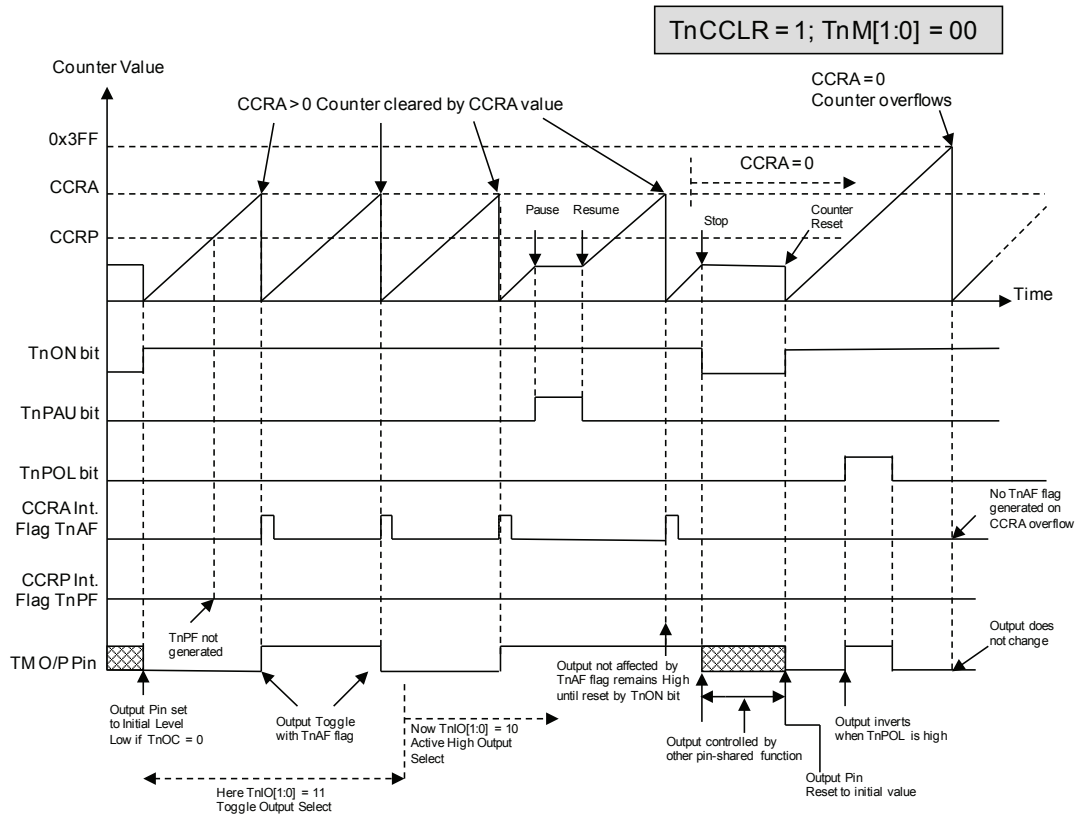

Compare Match Output Mode – TnCCLR=1

- Note:
1. With $TnCCLR = 1$ a Comparator A match will clear the counter
 2. The TM output pin controlled only by the TnAF flag
 3. The output pin reset to initial state by a TnON rising edge
 4. The TnPF flags is not generated when $TnCCLR = 1$
 5. $n = 0$

Timer/Counter Mode

To select this mode, bits T0M1 and T0M0 in the TM0C1 register should be set to 11 respectively. The Timer/Counter Mode operates in an identical way to the Compare Match Output Mode generating the same interrupt flags. The exception is that in the Timer/Counter Mode the TM output pin is not used. Therefore the above description and Timing Diagrams for the Compare Match Output Mode can be used to understand its function. As the TM output pin is not used in this mode, the pin can be used as a normal I/O pin or other pin-shared function.

PWM Output Mode

To select this mode, bits T0M1 and T0M0 in the TM0C1 register should be set to 10 respectively and also the T0IO1 and T0IO0 bits should be set to 10 respectively. The PWM function within the TM is useful for applications which require functions such as motor control, heating control, illumination control etc. By providing a signal of fixed frequency but of varying duty cycle on the TM output pin, a square wave AC waveform can be generated with varying equivalent DC RMS values.

As both the period and duty cycle of the PWM waveform can be controlled, the choice of generated waveform is extremely flexible. In the PWM mode, the T0CCLR bit has no effect as the PWM period. Both of the CCRA and CCRP registers are used to generate the PWM waveform, one register is used to clear the internal counter and thus control the PWM waveform frequency, while the other one is used to control the duty cycle. Which register is used to control either frequency or duty cycle is determined using the T0DPX bit in the TM0C1 register.

The PWM waveform frequency and duty cycle can therefore be controlled by the values in the CCRA and CCRP registers. An interrupt flag, one for each of the CCRA and CCRP, will be generated when a compare match occurs from either Comparator A or Comparator P. The T0OC bit in the TM0C1 register is used to select the required polarity of the PWM waveform while the two T0IO1 and T0IO0 bits are used to enable the PWM output or to force the TM output pin to a fixed high or low level. The T0POL bit is used to reverse the polarity of the PWM output waveform.

• **10-bit STM, PWM Mode, Edge-aligned Mode, T0DPX=0**

CCRP	1~255	0
Period	CCRP×256	1024
Duty	CCRA	

If $f_{SYS} = 16\text{MHz}$, TM clock source is $f_{SYS}/4$, CCRP = 2 and CCRA = 128,

The STM PWM output frequency = $(f_{SYS}/4) / 512 = f_{SYS}/2048 = 7.8125\text{kHz}$, duty = $128/512 = 25\%$.

If the Duty value defined by the CCRA register is equal to or greater than the Period value, then the PWM output duty is 100%.

• **10-bit STM, PWM Mode, Edge-aligned Mode, T0DPX=1**

CCRP	1~255	0
Period	CCRA	
Duty	CCRP×256	1024

The PWM output period is determined by the CCRA register value together with the TM clock while the PWM duty cycle is defined by the (CCRP×256) except when the CCRP value is equal to 0.

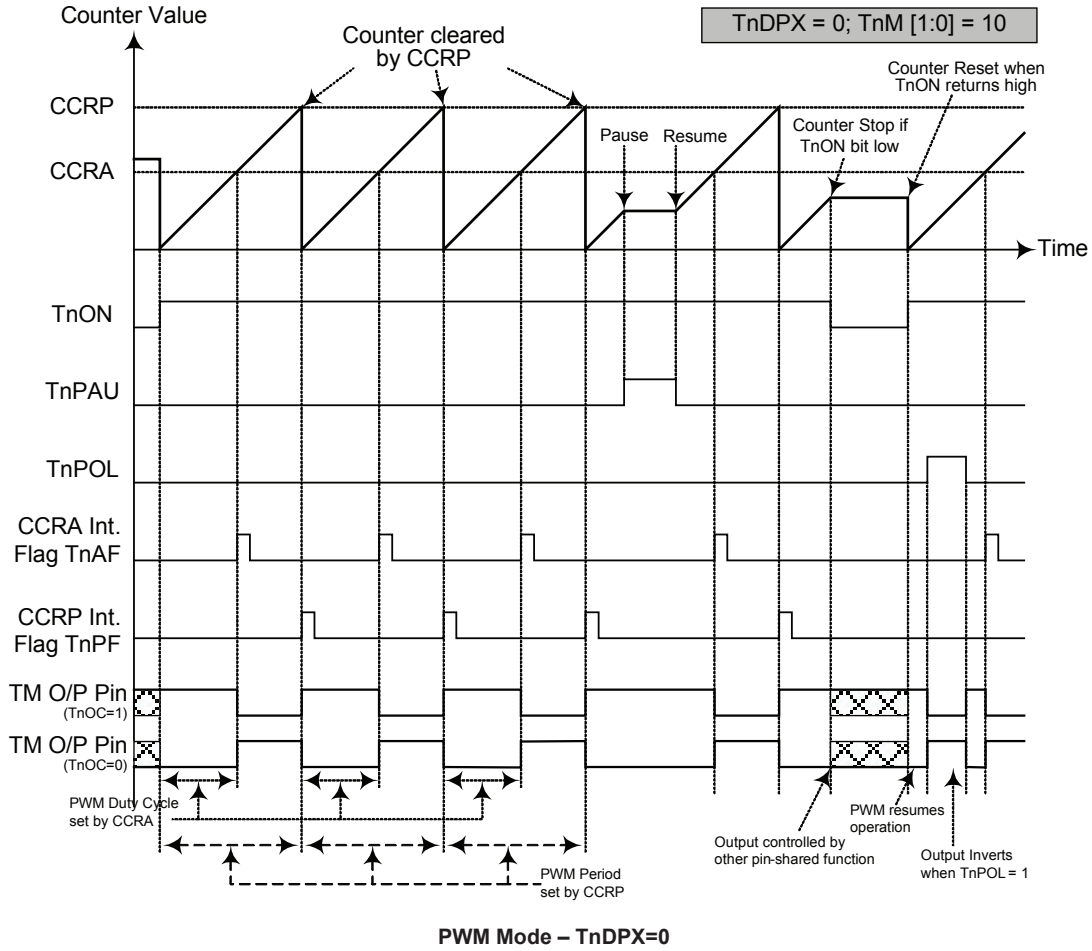

- Note: 1. Here TnDPX = 0 – Counter cleared by CCRP
 2. A counter clear sets PWM Period
 3. The internal PWM function continues running even when TnIO[1:0] = 00 or 01
 4. The TnCCLR bit has no influence on PWM operation
 5. n = 0

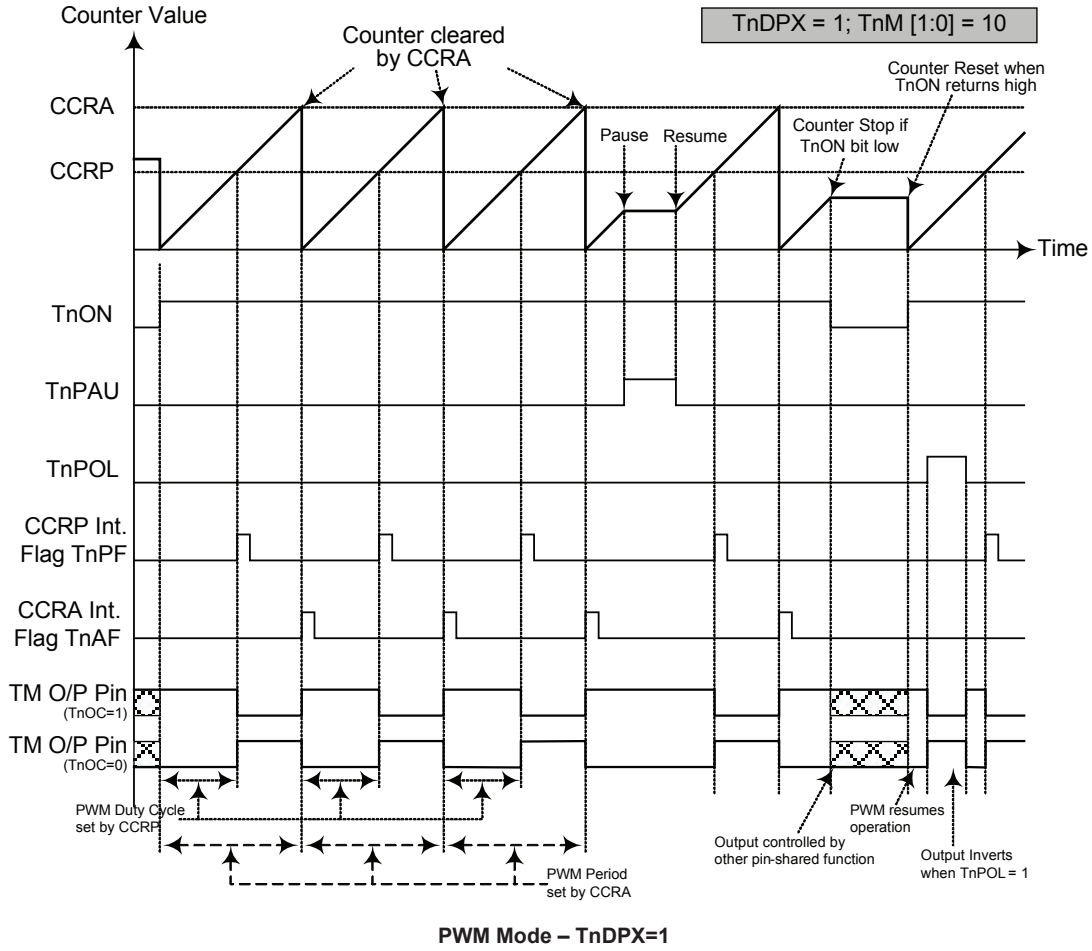

- Note: 1. Here TnDPX = 1 – Counter cleared by CCRA
 2. A counter clear sets PWM Period
 3. The internal PWM function continues even when TnIO[1:0] = 00 or 01
 4. The TnCCLR bit has no influence on PWM operation
 5. n = 0

Single Pulse Mode

To select this mode, bits T0M1 and T0M0 in the TM0C1 register should be set to 10 respectively and also the T0IO1 and T0IO0 bits should be set to 11 respectively. The Single Pulse Output Mode, as the name suggests, will generate a single shot pulse on the TM output pin.

The trigger for the pulse output leading edge is a low to high transition of the T0ON bit, which can be implemented using the application program. However in the Single Pulse Mode, the T0ON bit can also be made to automatically change from low to high using the external TCK0 pin, which will in turn initiate the Single Pulse output. When the T0ON bit transitions to a high level, the counter will start running and the pulse leading edge will be generated. The T0ON bit should remain high when the pulse is in its active state. The generated pulse trailing edge will be generated when the T0ON bit is cleared to zero, which can be implemented using the application program or when a compare match occurs from Comparator A.

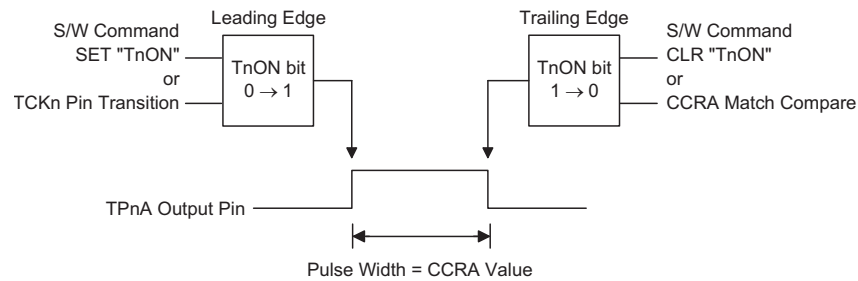

Single Pulse Generation (n=0)

However a compare match from Comparator A will also automatically clear the T0ON bit and thus generate the Single Pulse output trailing edge. In this way the CCRA value can be used to control the pulse width. A compare match from Comparator A will also generate a TM interrupt. The counter can only be reset back to zero when the T0ON bit changes from low to high when the counter restarts. In the Single Pulse Mode CCRP is not used. The T0CCLR and T0DPX bits are not used in this Mode.

Capture Input Mode

To select this mode bits T0M1 and T0M0 in the TM0C1 register should be set to 01 respectively. This mode enables external signals to capture and store the present value of the internal counter and can therefore be used for applications such as pulse width measurements. The external signal is supplied on the TP0_0 or TP0_1 pin, whose active edge can be either a rising edge, a falling edge or both rising and falling edges; the active edge transition type is selected using the T0IO1 and T0IO0 bits in the TM0C1 register. The counter is started when the T0ON bit changes from low to high which is initiated using the application program.

When the required edge transition appears on the TP0_0 or TP0_1 pin the present value in the counter will be latched into the CCRA registers and a TM interrupt generated. Irrespective of what events occur on the TP0_0 or TP0_1 pin the counter will continue to free run until the TnON bit changes from high to low. When a CCRP compare match occurs the counter will reset back to zero; in this way the CCRP value can be used to control the maximum counter value. When a CCRP compare match occurs from Comparator P, a TM interrupt will also be generated. Counting the number of overflow interrupt signals from the CCRP can be a useful method in measuring long pulse widths. The TnIO1 and TnIO0 bits can select the active trigger edge on the TP0_0 or TP0_1 pin to be a rising edge, falling edge or both edge types. If the TnIO1 and TnIO0 bits are both set high, then no capture operation will take place irrespective of what happens on the TP0_0 or TP0_1 pin, however it must be noted that the counter will continue to run.

As the TP0_0 or TP0_1 pin is pin shared with other functions, care must be taken if the TM is in the Input Capture Mode. This is because if the pin is setup as an output, then any transitions on this pin may cause an input capture operation to be executed. The T0CCLR and T0DPX bits are not used in this Mode.

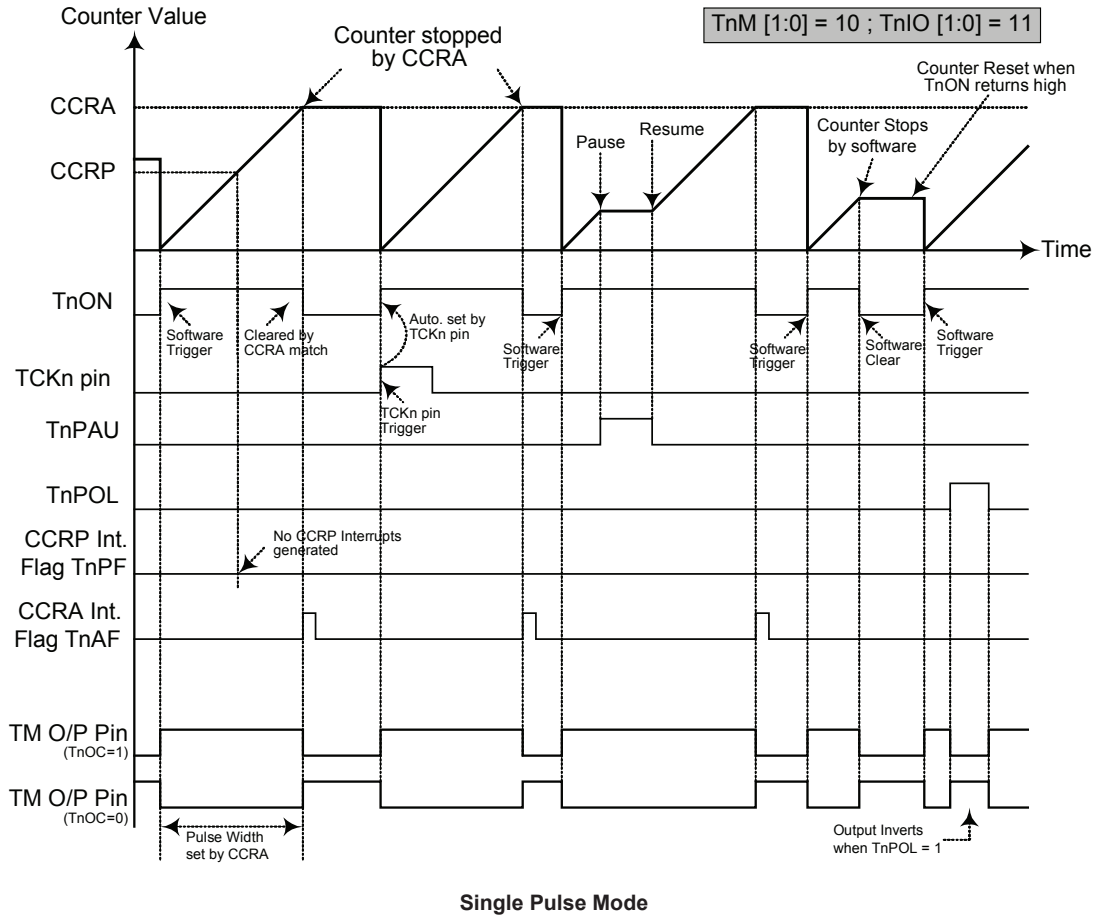

- Note:
1. Counter stopped by CCRA match
 2. CCRP is not used
 3. The pulse is triggered by the TCKn pin or setting the TnON bit high
 4. A TCKn pin active edge will automatically set the TnON bit high
 5. In the Single Pulse Mode, TnIO [1:0] must be set to "11" and can not be changed.
 6. n = 0

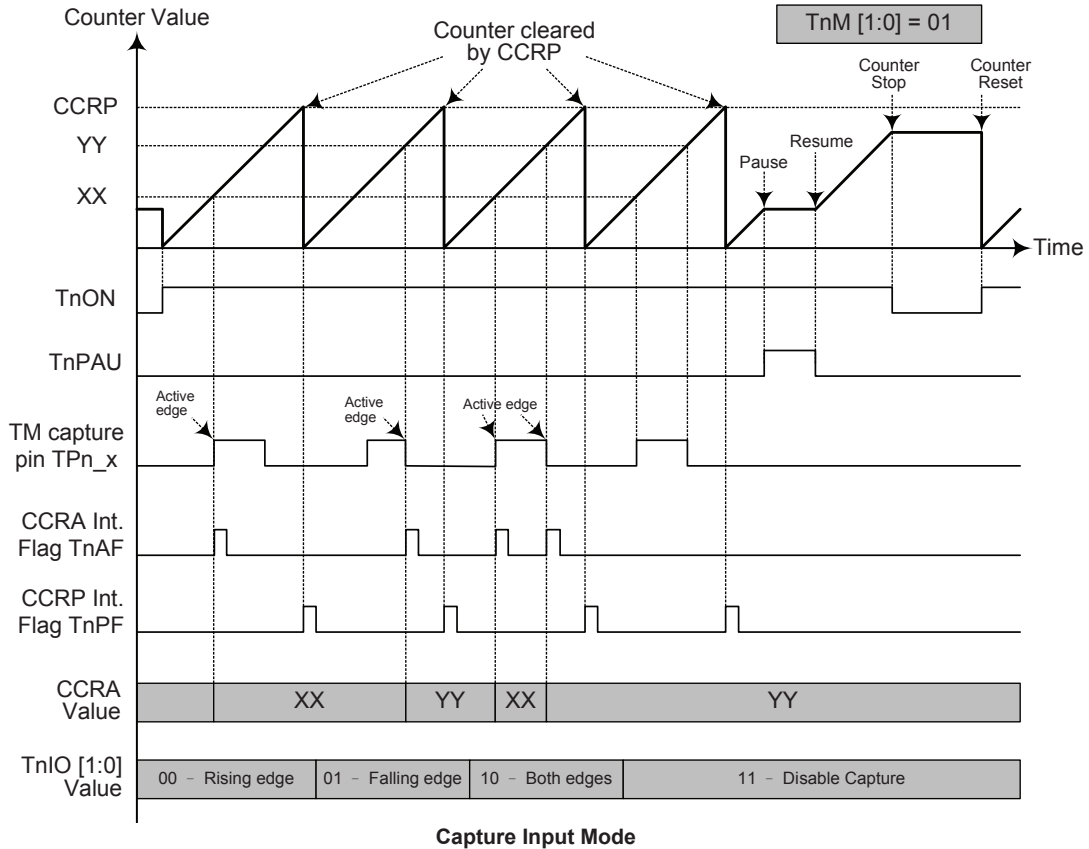

- Note: 1. TnM[1:0] = 01 and active edge set by the TnIO[1:0] bits
 2. A TM Capture input pin active edge transfers the counter value to CCRA
 3. The TnCCLR bit is not used
 4. No output function - TnOC and TnPOL bits are not used
 5. CCRP determines the counter value and the counter has a maximum count value when CCRP is equal to zero.
 6. n = 0

Periodic Type TM – PTM

The Periodic Type TM contains five operating modes, which are Compare Match Output, Timer/Event Counter, Capture Input, Single Pulse Output and PWM Output modes. The Periodic TM can also be controlled with an external input pin and can drive two external output pins.

Periodic TM Operation

At its core is a 10-bit count-up counter which is driven by a user selectable internal or external clock source. There are two internal comparators with the names, Comparator A and Comparator P. These comparators will compare the value in the counter with the CCRA and CCRP registers.

The only way of changing the value of the 10-bit counter using the application program, is to clear the counter by changing the T1ON bit from low to high. The counter will also be cleared automatically by a counter overflow or a compare match with one of its associated comparators. When these conditions occur, a TM interrupt signal will also usually be generated. The Periodic Type TM can operate in a number of different operational modes, can be driven by different clock sources including an input pin and can also control the output pin. All operating setup conditions are selected using relevant internal registers.

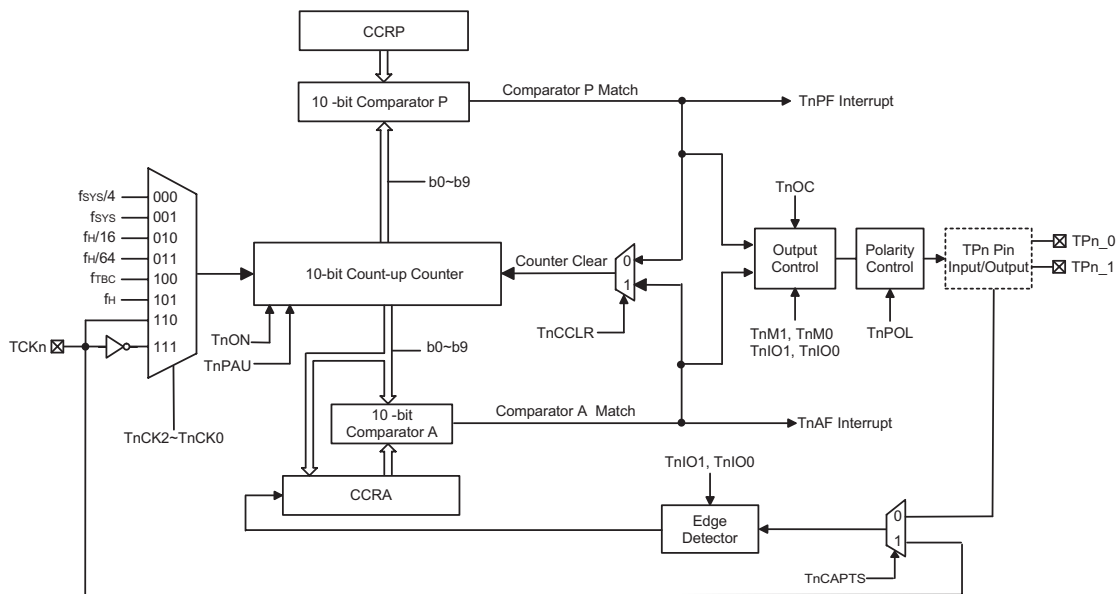

Periodic Type TM Block Diagram (n=1)

Periodic Type TM Register Description

Overall operation of the Periodic TM is controlled using a series of registers. A read only register pair exists to store the internal counter 10-bit value, while two read/write register pairs exist to store the internal 10-bit CCRA and CCRP value. The remaining two registers are control registers which setup the different operating and control modes.

Register Name	Bit							
	7	6	5	4	3	2	1	0
TM1C0	T1PAU	T1CK2	T1CK1	T1CK0	T1ON	—	—	—
TM1C1	T1M1	T1M0	T1IO1	T1IO0	T1OC	T1POL	T1CAPTS	T1CCLR
TM1DL	D7	D6	D5	D4	D3	D2	D1	D0
TM1DH	—	—	—	—	—	—	D9	D8
TM1AL	D7	D6	D5	D4	D3	D2	D1	D0
TM1AH	—	—	—	—	—	—	D9	D8
TM1RPL	D7	D6	D5	D4	D3	D2	D1	D0
TM1RPH	—	—	—	—	—	—	D9	D8

10-bit Periodic TM Register List

TM1C0 Register

Bit	7	6	5	4	3	2	1	0
Name	T1PAU	T1CK2	T1CK1	T1CK0	T1ON	—	—	—
R/W	R/W	R/W	R/W	R/W	R/W	—	—	—
POR	0	0	0	0	0	—	—	—

- Bit 7** **T1PAU:** TM1 Counter Pause Control
 0: Run
 1: Pause
 The counter can be paused by setting this bit high. Clearing the bit to zero restores normal counter operation. When in a Pause condition the TM will remain powered up and continue to consume power. The counter will retain its residual value when this bit changes from low to high and resume counting from this value when the bit changes to a low value again.
- Bit 6~4** **T1CK2~T1CK0:** Select TM1 Counter clock
 000: $f_{SYS}/4$
 001: f_{SYS}
 010: $f_H/16$
 011: $f_H/64$
 100: f_{TBC}
 101: f_H
 110: TCK1 rising edge clock
 111: TCK1 falling edge clock
 These three bits are used to select the clock source for the TM. The external pin clock source can be chosen to be active on the rising or falling edge. The clock source f_{SYS} is the system clock, while f_H and f_{TBC} are other internal clocks, the details of which can be found in the oscillator section.
- Bit 3** **T1ON:** TM1 Counter On/Off Control
 0: Off
 1: On
 This bit controls the overall on/off function of the TM. Setting the bit high enables the counter to run, clearing the bit disables the TM. Clearing this bit to zero will stop the counter from counting and turn off the TM which will reduce its power consumption. When the bit changes state from low to high the internal counter value will be reset to zero, however when the bit changes from high to low, the internal counter will retain its residual value until the bit returns high again.
 If the TM is in the Compare Match Output Mode then the TM output pin will be reset to its initial condition, as specified by the TM Output control bit, when the bit changes from low to high.
- Bit 2~0** Unimplemented, read as “0”

TM1C1 Register

Bit	7	6	5	4	3	2	1	0
Name	T1M1	T1M0	T1IO1	T1IO0	T1OC	T1POL	T1CAPTS	T1CCLR
R/W	R/W	R/W	R/W	R/W	R/W	R/W	R/W	R/W
POR	0	0	0	0	0	0	0	0

- Bit 7~6 **T1M1~T1M0:** Select TM1 Operation Mode
 00: Compare Match Output Mode
 01: Capture Input Mode
 10: PWM Mode or Single Pulse Output Mode
 11: Timer/Counter Mode
- These bits setup the required operating mode for the TM. To ensure reliable operation the TM should be switched off before any changes are made to the T1M1 and T1M0 bits. In the Timer/Counter Mode, the TM output pin control must be disabled.
- Bit 5~4 **T1IO1~T1IO0:** Select TP1_0, TP1_1 output function
- Compare Match Output Mode
 00: No change
 01: Output low
 10: Output high
 11: Toggle output
- PWM Mode/Single Pulse Output Mode
 00: PWM Output inactive state
 01: PWM Output active state
 10: PWM output
 11: Single pulse output
- Capture Input Mode
 00: Input capture at rising edge of TP1_0, TP1_1
 01: Input capture at falling edge of TP1_0, TP1_1
 10: Input capture at falling/rising edge of TP1_0, TP1_1
 11: Input capture disabled
- Timer/counter Mode
 Unused
- These two bits are used to determine how the TM output pin changes state when a certain condition is reached. The function that these bits select depends upon in which mode the TM is running.
- In the Compare Match Output Mode, the T1IO1 and T1IO0 bits determine how the TM output pin changes state when a compare match occurs from the Comparator A. The TM output pin can be setup to switch high, switch low or to toggle its present state when a compare match occurs from the Comparator A. When these bits are both zero, then no change will take place on the output. The initial value of the TM output pin should be setup using the T1OC bit. Note that the output level requested by the T1IO1 and T1IO0 bits must be different from the initial value setup using the T1OC bit otherwise no change will occur on the TM output pin when a compare match occurs. After the TM output pin changes state it can be reset to its initial level by changing the level of the T1ON bit from low to high.
- In the PWM Mode, the T1IO1 and T1IO0 bits determine how the TM output pin changes state when a certain compare match condition occurs. The PWM output function is modified by changing these two bits. It is necessary to change the values of the T1IO1 and T1IO0 bits only after the TM has been switched off. Unpredictable PWM outputs will occur if the T1IO1 and T1IO0 bits are changed when the TM is running.

- Bit 3 **TIOC:** TP1_0, TP1_1 Output control bit
 Compare Match Output Mode
 0: Initial low
 1: Initial high
 PWM Mode/Single Pulse Output Mode
 0: Active low
 1: Active high
 This is the output control bit for the TM output pin. Its operation depends upon whether TM is being used in the Compare Match Output Mode or in the PWM Mode/Single Pulse Output Mode. It has no effect if the TM is in the Timer/Counter Mode. In the Compare Match Output Mode it determines the logic level of the TM output pin before a compare match occurs. In the PWM Mode it determines if the PWM signal is active high or active low.
- Bit 2 **TIPOL:** TP1_0, TP1_1 Output polarity Control
 0: Non-invert
 1: Invert
 This bit controls the polarity of the TP1_0, TP1_1 output pin. When the bit is set high the TM output pin will be inverted and not inverted when the bit is zero. It has no effect if the TM is in the Timer/Counter Mode.
- Bit 1 **TICAPTS:** TM1 capture trigger source select
 0: From TP1_0 or TP1_1 pin
 1: From TCK1 pin
- Bit 0 **TICCLR:** Select TM1 Counter clear condition
 0: TM1 Comparatror P match
 1: TM1 Comparatror A match
 This bit is used to select the method which clears the counter. Remember that the Periodic TM contains two comparators, Comparator A and Comparator P, either of which can be selected to clear the internal counter. With the TICCLR bit set high, the counter will be cleared when a compare match occurs from the Comparator A. When the bit is low, the counter will be cleared when a compare match occurs from the Comparator P or with a counter overflow. A counter overflow clearing method can only be implemented if the CCRP bits are all cleared to zero. The TICCLR bit is not used in the PWM, Single Pulse or Input Capture Mode.

TM1DL Register

Bit	7	6	5	4	3	2	1	0
Name	D7	D6	D5	D4	D3	D2	D1	D0
R/W	R	R	R	R	R	R	R	R
POR	0	0	0	0	0	0	0	0

- Bit 7~0 **TM1DL:** TM1 Counter Low Byte Register bit 7 ~ bit 0
 TM1 10-bit Counter bit 7 ~ bit 0

TM1DH Register

Bit	7	6	5	4	3	2	1	0
Name	—	—	—	—	—	—	D9	D8
R/W	—	—	—	—	—	—	R	R
POR	—	—	—	—	—	—	0	0

- Bit 7~2 Unimplemented, read as “0”
 Bit 1~0 **TM1DH:** TM1 Counter High Byte Register bit 1 ~ bit 0
 TM1 10-bit Counter bit 9 ~ bit 8

TM1AL Register

Bit	7	6	5	4	3	2	1	0
Name	D7	D6	D5	D4	D3	D2	D1	D0
R/W (ADJ_SW=0)	R/W	R/W	R/W	R/W	R/W	R/W	R/W	R/W
R/W (ADJ_SW=1)	R	R	R	R	R	R	R	R
POR	0	0	0	0	0	0	0	0

Bit 7~0 **TM1AL**: TM1 CCRA Low Byte Register bit 7 ~ bit 0
TM1 10-bit CCRA bit 7 ~ bit 0

TM1AH Register

Bit	7	6	5	4	3	2	1	0
Name	—	—	—	—	—	—	D9	D8
R/W (ADJ_SW=0)	—	—	—	—	—	—	R/W	R/W
R/W (ADJ_SW=1)	—	—	—	—	—	—	R	R
POR	—	—	—	—	—	—	0	0

Bit 7~2 Unimplemented, read as “0”
Bit 1~0 **TM1AH**: TM1 CCRA High Byte Register bit 1 ~ bit 0
TM1 10-bit CCRA bit 9 ~ bit 8

Note: 1. ADJ_SW=0

T1ON=0, write directly to CCRA through TM1AL registers.

T1ON=1, wait RELOAD happens, TM1AL load to Comparator A.

2. ADJ_SW=1

Reload auto update the ADJBL/ADJBH to Comparator A.

TM1RPL Register

Bit	7	6	5	4	3	2	1	0
Name	D7	D6	D5	D4	D3	D2	D1	D0
R/W	R/W	R/W	R/W	R/W	R/W	R/W	R/W	R/W
POR	0	0	0	0	0	0	0	0

Bit 7~0 **TM1RPL**: TM1 CCRP Low Byte Register bit 7 ~ bit 0
TM1 10-bit CCRP bit 7 ~ bit 0

TM1RPH Register

Bit	7	6	5	4	3	2	1	0
Name	—	—	—	—	—	—	D9	D8
R/W	—	—	—	—	—	—	R/W	R/W
POR	—	—	—	—	—	—	0	0

Bit 7~2 Unimplemented, read as “0”
Bit 1~0 **TM1RPH**: TM1 CCRP High Byte Register bit 1 ~ bit 0
TM1 10-bit CCRP bit 9 ~ bit 8

Periodic Type TM Operating Modes

The Periodic Type TM can operate in one of five operating modes, Compare Match Output Mode, PWM Output Mode, Single Pulse Output Mode, Capture Input Mode or Timer/Counter Mode. The operating mode is selected using the T1M1 and T1M0 bits in the TM1C1 register.

Compare Match Output Mode

To select this mode, bits T1M1 and T1M0 in the TM1C1 register, should be all cleared to 00 respectively. In this mode once the counter is enabled and running it can be cleared by three methods. These are a counter overflow, a compare match from Comparator A and a compare match from Comparator P. When the T1CCLR bit is low, there are two ways in which the counter can be cleared. One is when a compare match occurs from Comparator P, the other is when the CCRP bits are all zero which allows the counter to overflow. Here both the T1AF and T1PF interrupt request flags for Comparator A and Comparator P respectively, will both be generated.

If the T1CCLR bit in the TM1C1 register is high then the counter will be cleared when a compare match occurs from Comparator A. However, here only the T1AF interrupt request flag will be generated even if the value of the CCRP bits is less than that of the CCRA registers. Therefore when T1CCLR is high no T1PF interrupt request flag will be generated. In the Compare Match Output Mode, the CCRA can not be set to “0”.

As the name of the mode suggests, after a comparison is made, the TM output pin, will change state. The TM output pin condition however only changes state when a T1AF interrupt request flag is generated after a compare match occurs from Comparator A. The T1PF interrupt request flag, generated from a compare match from Comparator P, will have no effect on the TM output pin. The way in which the TM output pin changes state are determined by the condition of the T1IO1 and T1IO0 bits in the TM1C1 register. The TM output pin can be selected using the T1IO1 and T1IO0 bits to go high, to go low or to toggle from its present condition when a compare match occurs from Comparator A. The initial condition of the TM output pin, which is setup after the T1ON bit changes from low to high, is setup using the T1OC bit. Note that if the T1IO1, T1IO0 bits are zero then no pin change will take place.

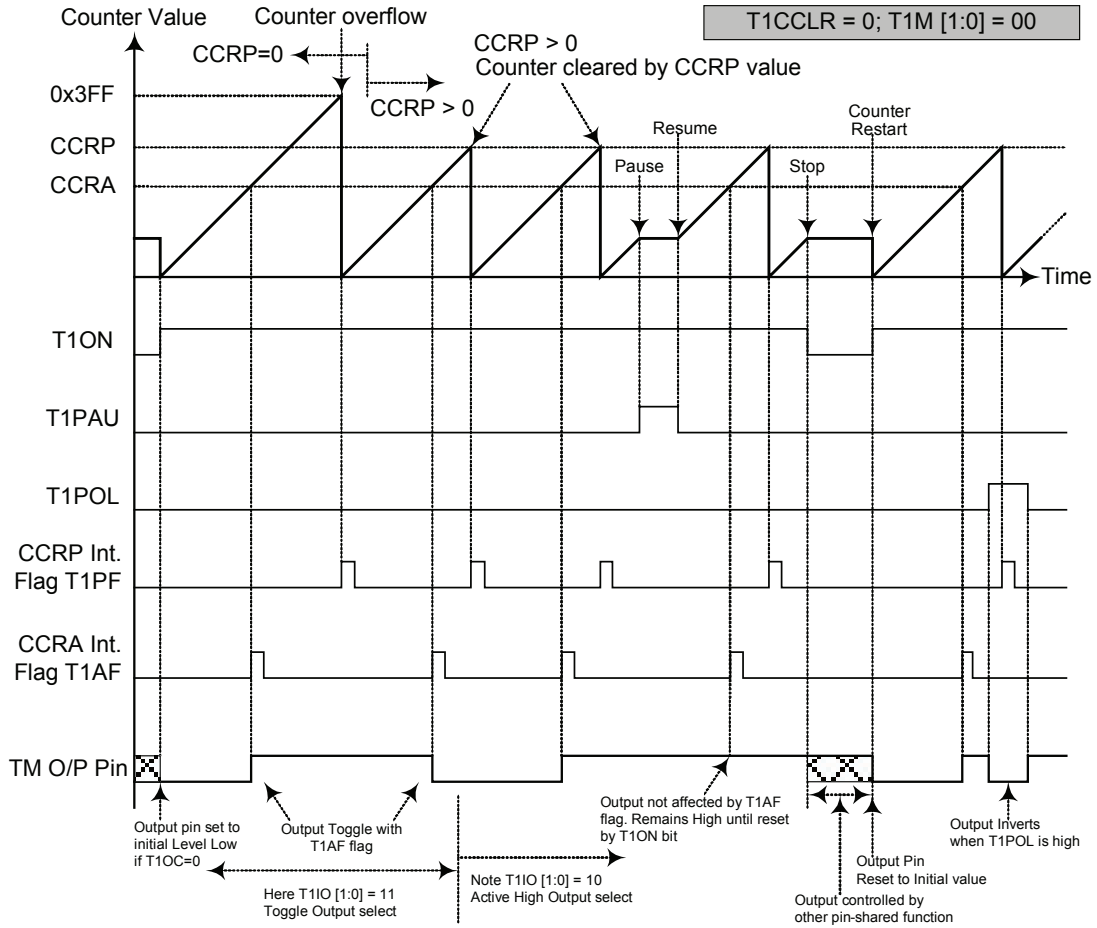

Compare Match Output Mode – T1CCLR = 0

- Note: 1. With T1CCLR = 0 – a Comparator P match will clear the counter
2. The TM output pin is controlled only by the T1AF flag
3. The output pin is reset to initial state by a T1ON bit rising edge

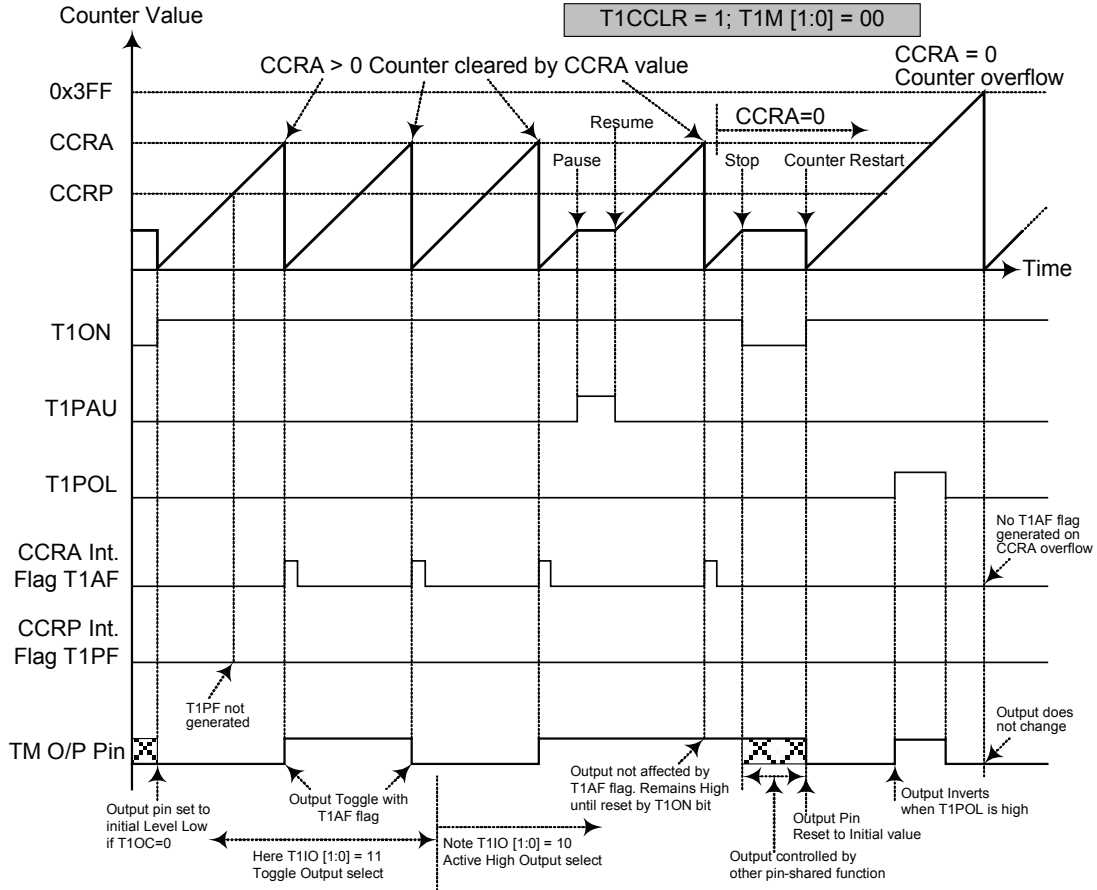

Compare Match Output Mode – T1CCLR = 1

- Note: 1. With T1CCLR = 1 – a Comparator A match will clear the counter
2. The TM output pin is controlled only by the T1AF flag
3. The output pin is reset to initial state by a T1ON rising edge
4. The T1PF flag is not generated when T1CCLR = 1

Timer/Counter Mode

To select this mode, bits T1M1 and T1M0 in the TM1C1 register should all be set to 11 respectively. The Timer/Counter Mode operates in an identical way to the Compare Match Output Mode generating the same interrupt flags. The exception is that in the Timer/Counter Mode the TM output pin is not used. Therefore the above description and Timing Diagrams for the Compare Match Output Mode can be used to understand its function. As the TM output pin is not used in this mode, the pin can be used as a normal I/O pin or other pin-shared function.

PWM Output Mode

To select this mode, bits T1M1 and T1M0 in the TM1C1 register should be set to 10 respectively and also the T1IO1 and T1IO0 bits should be set to 10 respectively. The PWM function within the TM is useful for applications which require functions such as motor control, heating control, illumination control etc. By providing a signal of fixed frequency but of varying duty cycle on the TM output pin, a square wave AC waveform can be generated with varying equivalent DC RMS values.

As both the period and duty cycle of the PWM waveform can be controlled, the choice of generated waveform is extremely flexible. In the PWM mode, the T1CCLR bit has no effect as the PWM period. Both of the CCRP and CCRA registers are used to generate the PWM waveform, one register is used to clear the internal counter and thus control the PWM waveform frequency, while the other one is used to control the duty cycle. The PWM waveform frequency and duty cycle can therefore be controlled by the values in the CCRA and CCRP registers.

An interrupt flag, one for each of the CCRA and CCRP, will be generated when a compare match occurs from either Comparator A or Comparator P. The T1OC bit in the TM1C1 register is used to select the required polarity of the PWM waveform while the two T1IO1 and T1IO0 bits are used to enable the PWM output or to force the TM output pin to a fixed high or low level. The T1POL bit is used to reverse the polarity of the PWM output waveform.

• **10-bit PTM, PWM Mode**

CCRP	CCRP=0~1023
Period	CCRP=0: period=1024 clocks CCRP=1~1023: period=1~1023 clocks
Duty	CCRA

If $f_{SYS} = 16\text{MHz}$, TM clock source select $f_{SYS}/4$, CCRP = 512 and CCRA = 128,

The PTM PWM output frequency = $(f_{SYS}/4) / (2 \times 256) = f_{SYS}/2048 = 7.8125\text{kHz}$, duty = $128/512 = 25\%$,

If the Duty value defined by the CCRA register is equal to or greater than the Period value, then the PWM output duty is 100%.

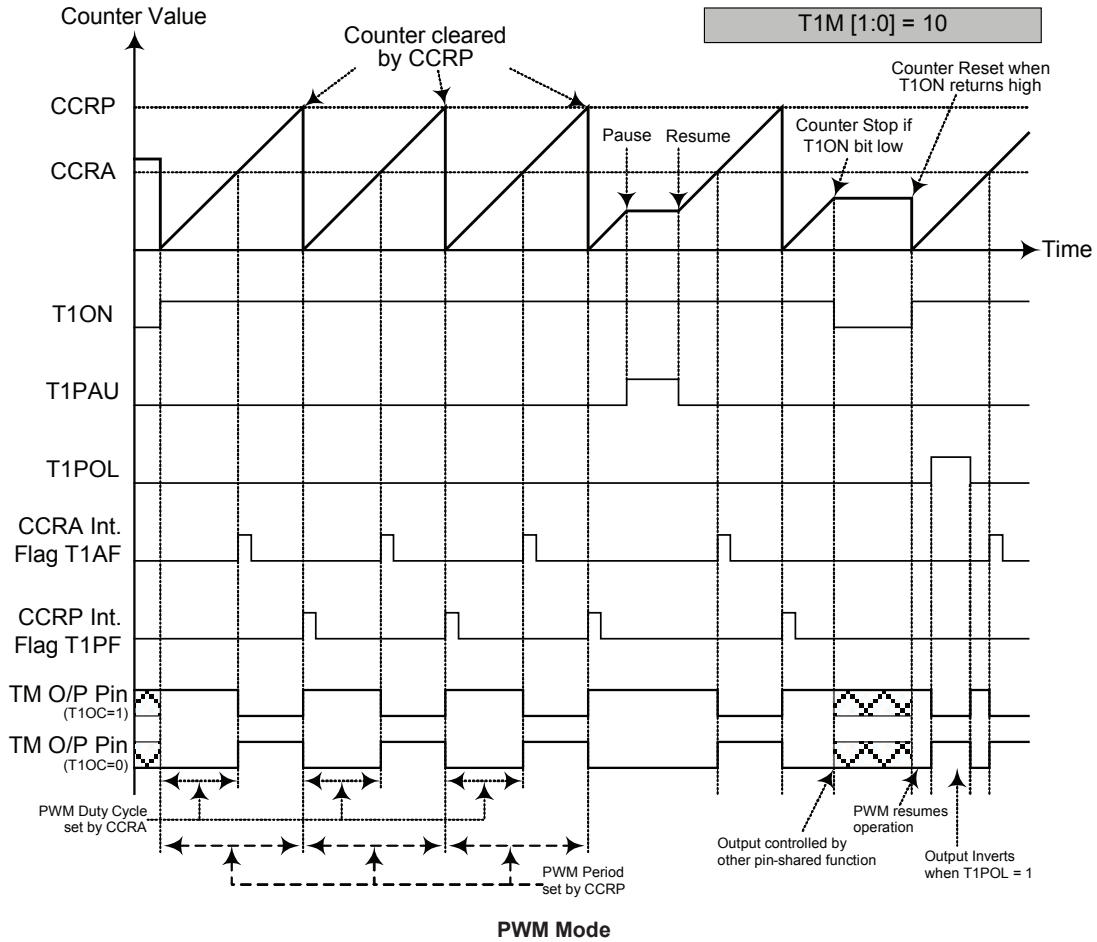

- Note: 1. Here Counter cleared by CCRP
 2. A counter clear sets the PWM Period
 3. The internal PWM function continues running even when T1IO[1:0] = 00 or 01
 4. The T1CCLR bit has no influence on PWM operation

Single Pulse Output Mode

To select this mode, the required bit pairs, TIM1 and TIM0 should be set to 10 respectively and also the corresponding T1IO1 and T1IO0 bits should be set to 11 respectively. The Single Pulse Output Mode, as the name suggests, will generate a single shot pulse on the TM output pin.

The trigger for the pulse output leading edge is a low to high transition of the T1ON bit, which can be implemented using the application program. However in the Single Pulse Mode, the T1ON bit can also be made to automatically change from low to high using the external TCK1 pin, which will in turn initiate the Single Pulse output. When the T1ON bit transitions to a high level, the counter will start running and the pulse leading edge will be generated. The T1ON bit should remain high when the pulse is in its active state. The generated pulse trailing edge will be generated when the T1ON bit is cleared to zero, which can be implemented using the application program or when a compare match occurs from Comparator A.

However a compare match from Comparator A will also automatically clear the T1ON bit and thus generate the Single Pulse output trailing edge. In this way the CCRA value can be used to control the pulse width. A compare match from Comparator A will also generate TM interrupts. The counter can only be reset back to zero when the T1ON bit changes from low to high when the counter restarts. In the Single Pulse Mode CCRP is not used. The TICCLR bit is also not used.

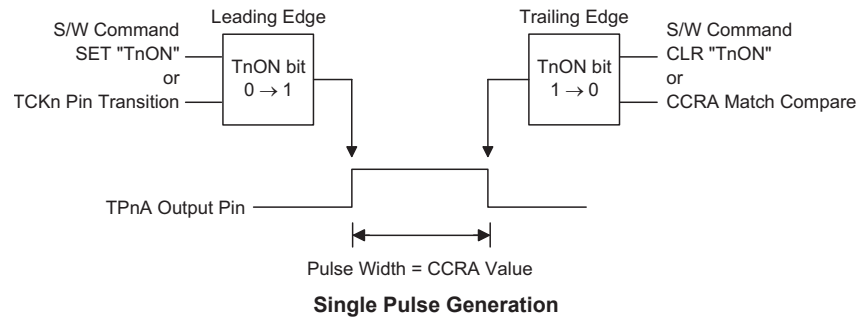

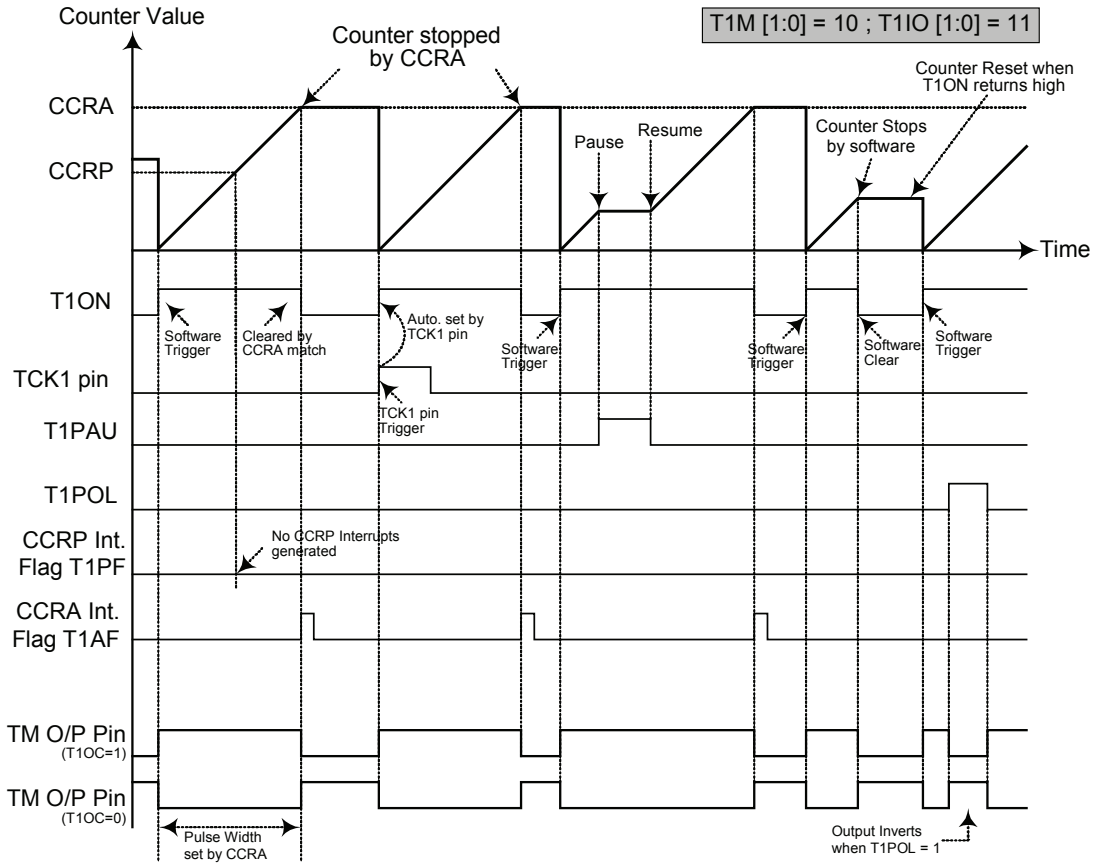

Single Pulse Mode

- Note:
1. Counter stopped by CCRA
 2. CCRP is not used
 3. The pulse is triggered by the TCK1 pin or by setting the T1ON bit high
 4. A TCK1 pin active edge will automatically set the T1ON bit high
 5. In the Single Pulse Mode, T1IO [1:0] must be set to "11" and can not be changed.

Capture Input Mode

To select this mode bits T1M1 and T1M0 in the TM1C1 register should be set to 01 respectively. This mode enables external signals to capture and store the present value of the internal counter and can therefore be used for applications such as pulse width measurements. The external signal is supplied on the TP1_0 or TP1_1 or TCK1 pin, selected by the T1CAPTS bit in the TM1C1 register. The input pin active edge can be either a rising edge, a falling edge or both rising and falling edges; the active edge transition type is selected using the T1IO1 and T1IO0 bits in the TM1C1 register. The counter is started when the T1ON bit changes from low to high which is initiated using the application program.

When the required edge transition appears on the TP1_0 or TP1_1 or TCK1 pin the present value in the counter will be latched into the CCRA register and a TM interrupt generated. Irrespective of what events occur on the TP1_0 or TP1_1 or TCK1 pin the counter will continue to free run until the T1ON bit changes from high to low. When a CCRP compare match occurs the counter will reset back to zero; in this way the CCRP value can be used to control the maximum counter value. When a CCRP compare match occurs from Comparator P, a TM interrupt will also be generated. Counting the number of overflow interrupt signals from the CCRP can be a useful method in measuring long pulse widths. The T1IO1 and T1IO0 bits can select the active trigger edge on the TP1_0 or TP1_1 or TCK1 pin to be a rising edge, falling edge or both edge types. If the T1IO1 and T1IO0 bits are both set high, then no capture operation will take place irrespective of what happens on the TP1_0 or TP1_1 or TCK1 pin, however it must be noted that the counter will continue to run.

As the TP1_0 or TP1_1 or TCK1 pin is pin shared with other functions, care must be taken if the TM1 is in the Capture Input Mode. This is because if the pin is setup as an output, then any transitions on this pin may cause an input capture operation to be executed. The T1CCLR, T1IOC and T1POL bits are not used in this Mode.

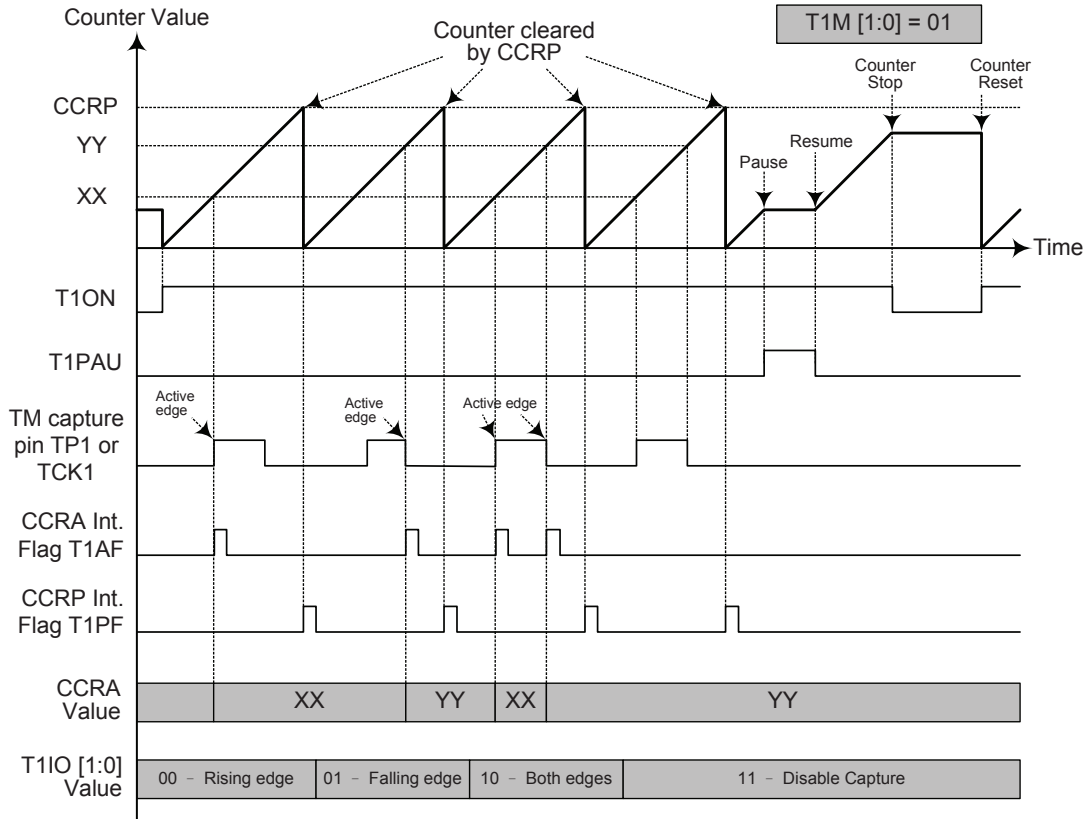

Capture Input Mode

- Note: 1. T1M[1:0] = 01 and active edge set by the T1IO[1:0] bits
 2. A TM Capture input pin active edge transfers counter value to CCRA
 3. The TICCLR bit is not used
 4. No output function – T1OC and T1POL bits are not used
 5. CCRP determines the counter value and the counter has a maximum count value when CCRP is equal to zero

Compact Type TM – CTM

Although the simplest form of the three TM types, the Compact TM type still contains three operating modes, which are Compare Match Output, Timer/Event Counter and PWM Output modes. The Compact TM can also be controlled with an external input pin and can drive one external output pin.

Name	TM No.	TM Input Pin	TM Output Pin
10-bit CTM	2	TCK2	TP2

Compact TM Operation

At its core is a 10-bit count-up counter which is driven by a user selectable internal or external clock source. There are also two internal comparators with the names, Comparator A and Comparator P. These comparators will compare the value in the counter with CCRP and CCRA registers. The CCRP is 8-bit wide whose value is compared with the highest eight bits in the counter while the CCRA is 10-bit wide and therefore compares with all counter bits.

The only way of changing the value of the 10-bit counter using the application program, is to clear the counter by changing the TnON bit from low to high. The counter will also be cleared automatically by a counter overflow or a compare match with one of its associated comparators. When these conditions occur, a TM interrupt signal will also usually be generated. The Compact Type TM can operate in a number of different operational modes, can be driven by different clock sources including an input pin and can also control an output pin. All operating setup conditions are selected using relevant internal registers.

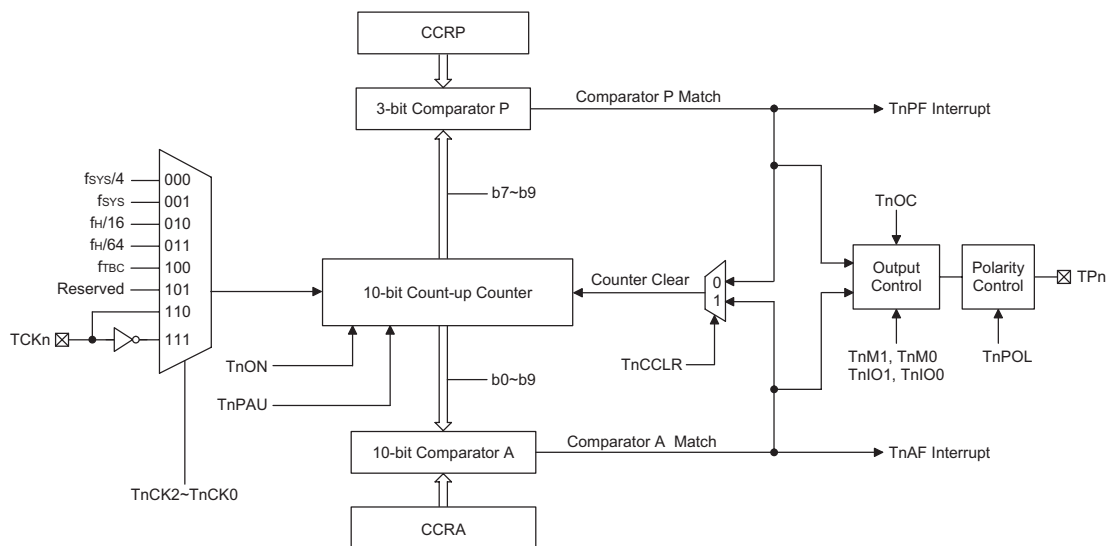

Compact Type TM Block Diagram (n=2)

Compact Type TM Register Description

Overall operation of the Compact TM is controlled using a series of registers. A read only register pair exists to store the internal counter 10-bit value, while a read/write register pair exists to store the internal 10-bit CCRA value. There is also a read/write register used to store the internal 3-bit CCRP value. The remaining two registers are control registers which setup the different operating and control modes.

Register Name	Bit							
	7	6	5	4	3	2	1	0
TMnC0	TnPAU	TnCK2	TnCK1	TnCK0	TnON	T2RP2	T2RP1	T2RP0
TMnC1	TnM1	TnM0	TnIO1	TnIO0	TnOC	TnPOL	TnDPX	TnCCLR
TMnDL	D7	D6	D5	D4	D3	D2	D1	D0
TMnDH	—	—	—	—	—	—	D9	D8
TMnAL	D7	D6	D5	D4	D3	D2	D1	D0
TMnAH	—	—	—	—	—	—	D9	D8

10-bit Compact TM Register List (n=2)

TMnC0 Register (n=2)

Bit	7	6	5	4	3	2	1	0
Name	TnPAU	TnCK2	TnCK1	TnCK0	TnON	TnRP2	TnRP1	TnRP0
R/W	R/W	R/W	R/W	R/W	R/W	R/W	R/W	R/W
POR	0	0	0	0	0	0	0	0

Bit 7 **TnPAU:** TMn Counter Pause Control

0: Run
1: Pause

The counter can be paused by setting this bit high. Clearing the bit to zero restores normal counter operation. When in a Pause condition the TM will remain powered up and continue to consume power. The counter will retain its residual value when this bit changes from low to high and resume counting from this value when the bit changes to a low value again.

Bit 6~4 **TnCK2~TnCK0:** Select TMn Counter clock

000: $f_{SYS}/4$
001: f_{SYS}
010: $f_H/16$
011: $f_H/64$
100: f_{TBC}
101: Reserved
110: TCKn rising edge clock
111: TCKn falling edge clock

These three bits are used to select the clock source for the TM. The external pin clock source can be chosen to be active on the rising or falling edge. The clock source f_{SYS} is the system clock, while f_H and f_{TBC} are other internal clocks, the details of which can be found in the oscillator section.

- Bit 3 **TnON:** TMn Counter On/Off Control
 0: Off
 1: On
- This bit controls the overall on/off function of the TM. Setting the bit high enables the counter to run, clearing the bit disables the TM. Clearing this bit to zero will stop the counter from counting and turn off the TM which will reduce its power consumption. When the bit changes state from low to high the internal counter value will be reset to zero, however when the bit changes from high to low, the internal counter will retain its residual value. If the TM is in the Compare Match Output Mode then the TM output pin will be reset to its initial condition, as specified by the TnOC bit, when the TnON bit changes from low to high.
- Bit 2~0 **TnRP2~TnRP0:** TMn CCRP 3-bit register, compared with the TM0 Counter bit 9~bit 7 Comparator P Match Period
 000: 1024 TM0 clocks
 001: 128 TM0 clocks
 010: 256 TM0 clocks
 011: 384 TM0 clocks
 100: 512 TM0 clocks
 101: 640 TM0 clocks
 110: 768 TM0 clocks
 111: 896 TM0 clocks

TMnC1 Register (n=2)

Bit	7	6	5	4	3	2	1	0
Name	TnM1	TnM0	TnIO1	TnIO0	TnOC	TnPOL	TnDPX	TnCCLR
R/W	R/W	R/W	R/W	R/W	R/W	R/W	R/W	R/W
POR	0	0	0	0	0	0	0	0

- Bit 7~6 **TnM1, TnM0:** Select TMn Operating Mode
 00: Compare Match Output Mode
 01: Undefined
 10: PWM Mode
 11: Timer/Counter Mode
- These bits setup the required operating mode for the TM. To ensure reliable operation the TM should be switched off before any changes are made to the TnM1 and TnM0 bits. In the Timer/Counter Mode, the TM output pin control must be disabled.
- Bit 5~4 **TnIO1, TnIO0:** Select TPn output function
- Compare Match Output Mode
 00: No change
 01: Output low
 10: Output high
 11: Toggle output
- PWM Mode
 00: PWM Output inactive state
 01: PWM Output active state
 10: PWM output
 11: Undefined
- Timer/Counter Mode
 Unused
- These two bits are used to determine how the TM output pin changes state when a certain condition is reached. The function that these bits select depends upon in which mode the TM is running.

In the Compare Match Output Mode, the TnIO1 and TnIO0 bits determine how the TM output pin changes state when a compare match occurs from the Comparator A. The TM output pin can be setup to switch high, switch low or to toggle its present state when a compare match occurs from the Comparator A. When the bits are both zero, then no change will take place on the output. The initial value of the TM output pin should be setup using the TnOC bit in the TMnC1 register. Note that the output level requested by the TnIO1 and TnIO0 bits must be different from the initial value setup using the TnOC bit otherwise no change will occur on the TM output pin when a compare match occurs. After the TM output pin changes state, it can be reset to its initial level by changing the level of the TnON bit from low to high.

In the PWM Mode, the TnIO1 and TnIO0 bits determine how the TM output pin changes state when a certain compare match condition occurs. The PWM output function is modified by changing these two bits. It is necessary to only change the values of the TnIO1 and TnIO0 bits only after the TMn has been switched off. Unpredictable PWM outputs will occur if the TnIO1 and TnIO0 bits are changed when the TM is running.

- Bit 3 **TnOC:** TPn Output control bit
 Compare Match Output Mode
 0: Initial low
 1: Initial high
 PWM Mode
 0: Active low
 1: Active high

This is the output control bit for the TM output pin. Its operation depends upon whether TM is being used in the Compare Match Output Mode or in the PWM Mode. It has no effect if the TM is in the Timer/Counter Mode. In the Compare Match Output Mode it determines the logic level of the TM output pin before a compare match occurs. In the PWM Mode it determines if the PWM signal is active high or active low.

- Bit 2 **TnPOL:** TPn Output polarity Control
 0: Non-invert
 1: Invert

This bit controls the polarity of the TPn output pin. When the bit is set high the TM output pin will be inverted and not inverted when the bit is zero. It has no effect if the TM is in the Timer/Counter Mode.

- Bit 1 **TnDPX:** TMn PWM period/duty Control
 0: CCRP - period; CCRA - duty
 1: CCRP - duty; CCRA - period

This bit, determines which of the CCRA and CCRP registers are used for period and duty control of the PWM waveform.

- Bit 0 **TnCCLR:** Select TMn Counter clear condition
 0: TMn Comparatr P match
 1: TMn Comparatr A match

This bit is used to select the method which clears the counter. Remember that the Compact TM contains two comparators, Comparator A and Comparator P, either of which can be selected to clear the internal counter. With the TnCCLR bit set high, the counter will be cleared when a compare match occurs from the Comparator A. When the bit is low, the counter will be cleared when a compare match occurs from the Comparator P or with a counter overflow. A counter overflow clearing method can only be implemented if the CCRP bits are all cleared to zero. The TnCCLR bit is not used in the PWM Mode.

TMnDL Register (n=2)

Bit	7	6	5	4	3	2	1	0
Name	D7	D6	D5	D4	D3	D2	D1	D0
R/W	R	R	R	R	R	R	R	R
POR	0	0	0	0	0	0	0	0

Bit 7~0 **D7~D0:** TMn Counter Low Byte Register bit 7 ~ bit 0
TMn 10-bit Counter bit 7 ~ bit 0

TMnDH Register (n=2)

Bit	7	6	5	4	3	2	1	0
Name	—	—	—	—	—	D10	D9	D8
R/W	—	—	—	—	—	R	R	R
POR	—	—	—	—	—	0	0	0

Bit 7~0 **D9~D8:** TMn Counter High Byte Register bit 7 ~ bit 0
TMn 10-bit Counter bit 9 ~ bit 8

TMnAL Register (n=2)

Bit	7	6	5	4	3	2	1	0
Name	D7	D6	D5	D4	D3	D2	D1	D0
R/W	R/W	R/W	R/W	R/W	R/W	R/W	R/W	R/W
POR	0	0	0	0	0	0	0	0

Bit 7~0 **D7~D0:** TMn CCRA Low Byte Register bit 7 ~ bit 0
TMn 10-bit CCRA bit 7 ~ bit 0

TMnAH Register (n=2)

Bit	7	6	5	4	3	2	1	0
Name	—	—	—	—	—	D10	D9	D8
R/W	—	—	—	—	—	R/W	R/W	R/W
POR	—	—	—	—	—	0	0	0

Bit 7~0 **D9~D8:** TMn CCRA High Byte Register bit 7 ~ bit 0
TMn 10-bit CCRA bit 10 ~ bit 8

Compact Type TM Operating Modes

The Compact Type TM can operate in one of three operating modes, Compare Match Output Mode, PWM Mode or Timer/Counter Mode. The operating mode is selected using the TnM1 and TnM0 bits in the TMnC1 register.

Compare Match Output Mode

To select this mode, bits TnM1 and TnM0 in the TMnC1 register, should be set to 00B respectively. In this mode once the counter is enabled and running it can be cleared by three methods. These are a counter overflow, a compare match from Comparator A and a compare match from Comparator P. When the TnCCLR bit is low, there are two ways in which the counter can be cleared. One is when a compare match occurs from Comparator P, the other is when the CCRP bits are all zero which allows the counter to overflow. Here both TnAF and TnPF interrupt request flags for the Comparator A and Comparator P respectively, will both be generated.

If the TnCCLR bit in the TMnC1 register is high then the counter will be cleared when a compare match occurs from Comparator A. However, here only the TnAF interrupt request flag will be generated even if the value of the CCRP bits is less than that of the CCRA registers. Therefore when TnCCLR is high no TnPF interrupt request flag will be generated. If the CCRA bits are all zero, the counter will overflow when it reaches its maximum 10-bit, 3FF Hex, value, however here the TnAF interrupt request flag will not be generated.

As the name of the mode suggests, after a comparison is made, the TM output pin will change state. The TM output pin condition however only changes state when a TnAF interrupt request flag is generated after a compare match occurs from Comparator A. The TnPF interrupt request flag, generated from a compare match occurs from Comparator P, will have no effect on the TM output pin. The way in which the TM output pin changes state are determined by the condition of the TnIO1 and TnIO0 bits in the TMnC1 register. The TM output pin can be selected using the TnIO1 and TnIO0 bits to go high, to go low or to toggle from its present condition when a compare match occurs from Comparator A. The initial condition of the TM output pin, which is setup after the TnON bit changes from low to high, is setup using the TnOC bit. Note that if the TnIO1 and TnIO0 bits are zero then no pin change will take place.

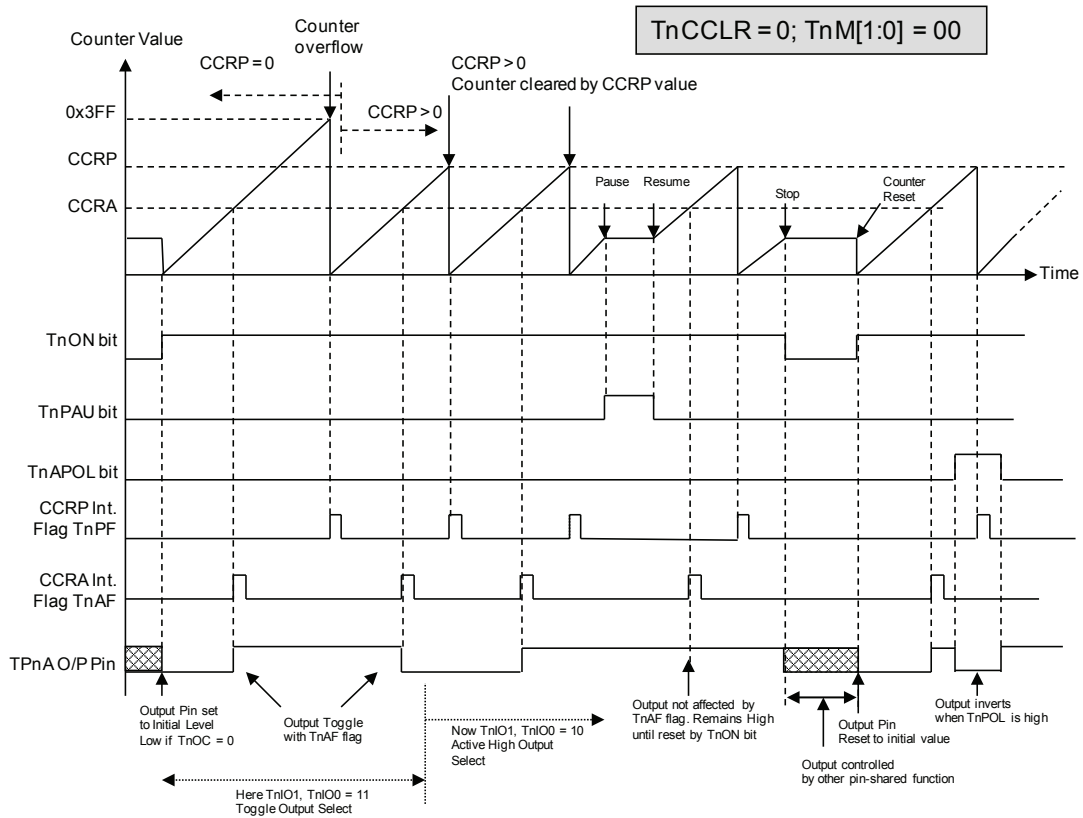

Compare Match Output Mode – TnCCLR = 0 (n=2)

- Note: 1. With TnCCLR=0, a Comparator P match will clear the counter
 2. The TM output pin is controlled only by the TnAF flag
 3. The output pin is reset to its initial state by a TnON bit rising edge

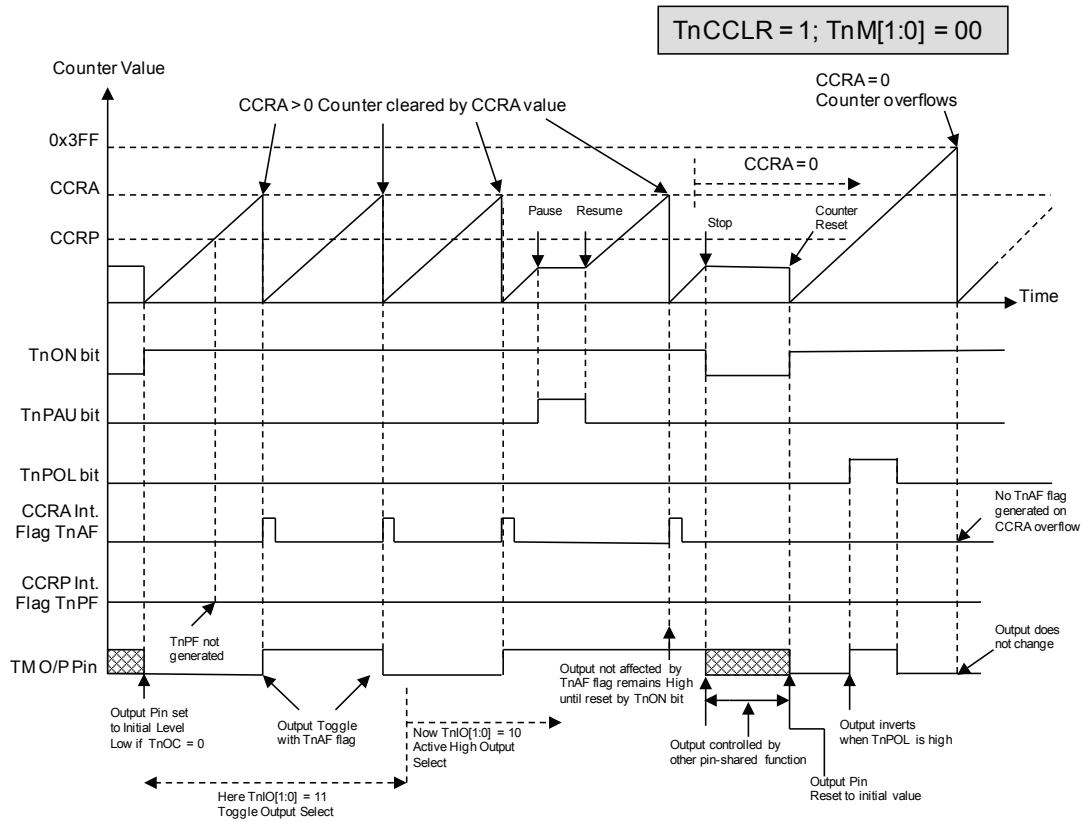

Compare Match Output Mode – TnCCLR = 1 (n=2)

- Note:
1. With $TnCCLR=1$, a Comparator A match will clear the counter
 2. The TM output pin is controlled only by the TnAF flag
 3. The output pin is reset to its initial state by a TnON bit rising edge
 4. The TnPF flag is not generated when $TnCCLR=1$

Timer/Counter Mode

To select this mode, bits TnM1 and TnM0 in the TMnC1 register should be set to 11 respectively. The Timer/Counter Mode operates in an identical way to the Compare Match Output Mode generating the same interrupt flags. The exception is that in the Timer/Counter Mode the TM output pin is not used. Therefore the above description and Timing Diagrams for the Compare Match Output Mode can be used to understand its function. As the TM output pin is not used in this mode, the pin can be used as a normal I/O pin or other pin-shared function.

PWM Output Mode

To select this mode, bits TnM1 and TnM0 in the TMnC1 register should be set to 10 respectively. The PWM function within the TM is useful for applications which require functions such as motor control, heating control, illumination control etc. By providing a signal of fixed frequency but of varying duty cycle on the TM output pin, a square wave AC waveform can be generated with varying equivalent DC RMS values.

As both the period and duty cycle of the PWM waveform can be controlled, the choice of generated waveform is extremely flexible. In the PWM mode, the TnCCLR bit has no effect on the PWM operation. Both of the CCRA and CCRP registers are used to generate the PWM waveform, one register is used to clear the internal counter and thus control the PWM waveform frequency, while the other one is used to control the duty cycle. Which register is used to control either frequency or duty cycle is determined using the TnDPX bit in the TMnC1 register. The PWM waveform frequency and duty cycle can therefore be controlled by the values in the CCRA and CCRP registers.

An interrupt flag, one for each of the CCRA and CCRP, will be generated when a compare match occurs from either Comparator A or Comparator P. The TnOC bit in the TMnC1 register is used to select the required polarity of the PWM waveform while the two TnIO1 and TnIO0 bits are used to enable the PWM output or to force the TM output pin to a fixed high or low level. The TnPOL bit is used to reverse the polarity of the PWM output waveform.

• **10-bit CTM, PWM Mode, Edge-aligned Mode, TnDPX=0**

CCRP	001b	010b	011b	100b	101b	110b	111b	000b
Period	128	256	384	512	640	768	896	1024
Duty	CCRA							

If $f_{SYS} = 16\text{MHz}$, TM clock source select $f_{SYS}/4$, CCRP = 2 and CCRA = 128,

The STM PWM output frequency = $(f_{SYS}/4)/(2 \times 256) = f_{SYS}/2048 = 7.8125\text{kHz}$, duty = $128/(2 \times 256) = 25\%$.

If the Duty value defined by the CCRA register is equal to or greater than the Period value, then the PWM output duty is 100%.

• **10-bit CTM, PWM Mode, Edge-aligned Mode, TnDPX=1**

CCRP	001b	010b	011b	100b	101b	110b	111b	000b
Period	CCRA							
Duty	128	256	384	512	640	768	896	1024

The PWM output period is determined by the CCRA register value together with the TM clock while the PWM duty cycle is defined by the CCRP value.

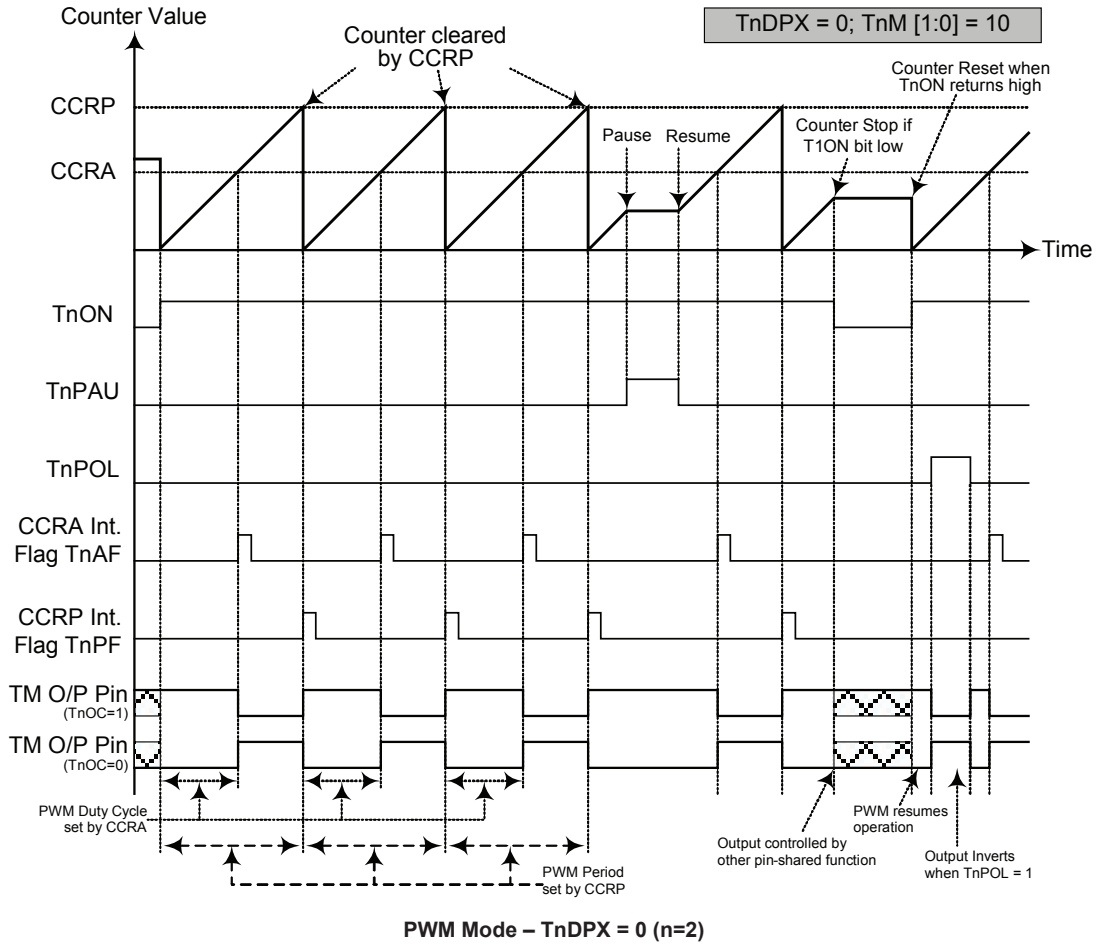

- Note: 1. Here TnDPX=0 – Counter cleared by CCRP
 2. A counter clear sets the PWM Period
 3. The internal PWM function continues even when TnIO [1:0] = 00 or 01
 4. The TnCCLR bit has no influence on PWM operation

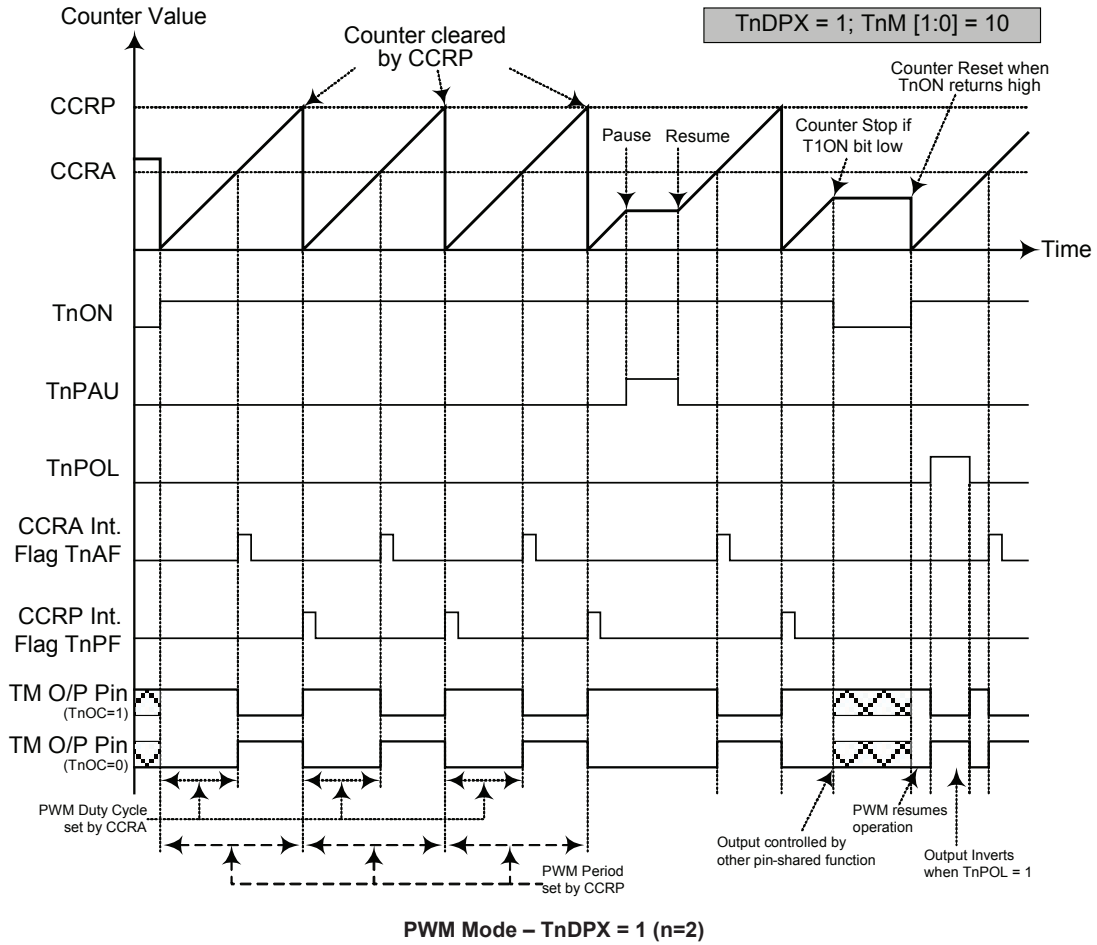

- Note: 1. Here TnDPX=1 – Counter cleared by CCRA
 2. A counter clear sets the PWM Period
 3. The internal PWM function continues even when TnIO [1:0] = 00 or 01
 4. The TnCCLR bit has no influence on PWM operation

Analog to Digital Converter

The need to interface to real world analog signals is a common requirement for many electronic systems. However, to properly process these signals by a microcontroller, they must first be converted into digital signals by A/D converters. By integrating the A/D conversion electronic circuitry into the microcontroller, the need for external components is reduced significantly with the corresponding follow-on benefits of lower costs and reduced component space requirements.

A/D Overview

The device contains a multi-channel analog to digital converter which can directly interface to external analog signals, such as that from sensors or other control signals and convert these signals directly into a 12-bit digital value.

Input Channels	A/D Channel Select Bits	Input Pins
6+2	ACS4, ACS3~ACS0	AN0, AN2~AN8

The accompanying block diagram shows the overall internal structure of the A/D converter, together with its associated registers.

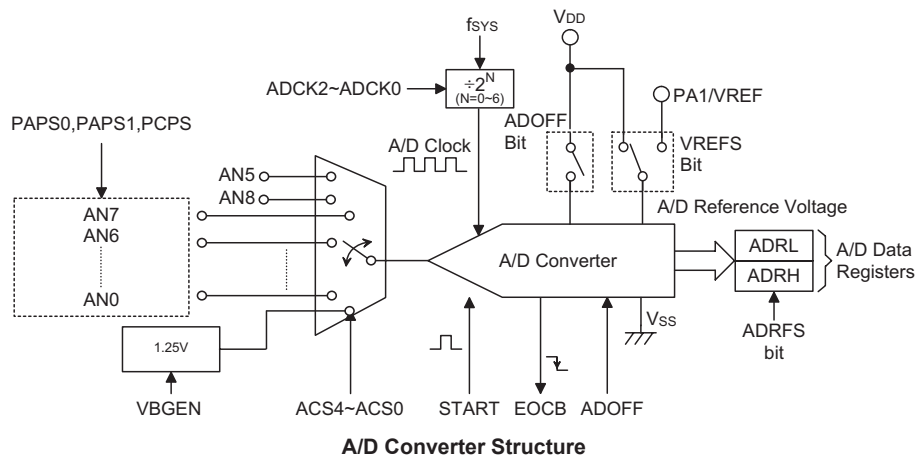

A/D Converter Register Description

Overall operation of the A/D converter is controlled using four registers. A read only register pair exists to store the ADC data 12-bit value. The remaining two registers are control registers which setup the operating and control function of the A/D converter.

Register Name	Bit							
	7	6	5	4	3	2	1	0
ADRL (ADRF=0)	D3	D2	D1	D0	—	—	—	—
ADRL (ADRF=1)	D7	D6	D5	D4	D3	D2	D1	D0
ADRH (ADRF=0)	D11	D10	D9	D8	D7	D6	D5	D4
ADRH (ADRF=1)	—	—	—	—	D11	D10	D9	D8
ADCR0	START	EOCB	ADOFF	ADRF	ACS3	ACS2	ACS1	ACS0
ADCR1	ACS4	VBGEN	—	VREFS	—	ADCK2	ADCK1	ADCK0

A/D Converter Register List

A/D Converter Data Registers – ADRL, ADRH

As the devices contain an internal 12-bit A/D converter, they require two data registers to store the converted value. These are a high byte register, known as ADRH, and a low byte register, known as ADRL. After the conversion process takes place, these registers can be directly read by the microcontroller to obtain the digitised conversion value. As only 12 bits of the 16-bit register space is utilised, the format in which the data is stored is controlled by the ADRFS bit in the ADCR0 register as shown in the accompanying table. D0~D11 are the A/D conversion result data bits. Any unused bits will be read as zero.

ADRFS	ADRH								ADRL							
	7	6	5	4	3	2	1	0	7	6	5	4	3	2	1	0
0	D11	D10	D9	D8	D7	D6	D5	D4	D3	D2	D1	D0	0	0	0	0
1	0	0	0	0	D11	D10	D9	D8	D7	D6	D5	D4	D3	D2	D1	D0

A/D Data Registers

A/D Converter Control Registers – ADCR0, ADCR1

To control the function and operation of the A/D converter, two control registers known as ADCR0 and ADCR1 are provided. These 8-bit registers define functions such as the selection of which analog channel is connected to the internal A/D converter, the digitised data format, the A/D clock source as well as controlling the start function and monitoring the A/D converter end of conversion status. The ACS3~ACS0 bits in the ADCR0 register and ACS4 bit is the ADCR1 register define the ADC input channel number. As the device contains only one actual analog to digital converter hardware circuit, each of the individual 8 analog inputs must be routed to the converter. It is the function of the ACS4~ACS0 bits to determine which analog channel input signals or internal 1.25V is actually connected to the internal A/D converter.

The PAPS0, PAPS1 and PCPS control registers determine which pins are used as analog inputs for the A/D converter input and which pins are not to be used as the A/D converter input. When the pin is selected to be an A/D input, its original function whether it is an I/O or other pin-shared function will be removed. In addition, any internal pull-high resistors connected to these pins will be automatically removed if the pin is selected to be an A/D input.

• ADCR0 Register

Bit	7	6	5	4	3	2	1	0
Name	START	EOCB	ADOFF	ADRFS	ACS3	ACS2	ACS1	ACS0
R/W	R/W	R	R/W	R/W	R/W	R/W	R/W	R/W
POR	0	1	1	0	0	0	0	0

Bit 7 START: Start the A/D conversion
 0→1→0: start
 0→1: reset the A/D converter and set EOCB to “1”
 This bit is used to initiate an A/D conversion process. The bit is normally low but if set high and then cleared low again, the A/D converter will initiate a conversion process. When the bit is set high the A/D converter will be reset.

Bit 6 EOCB: End of A/D conversion flag
 0: A/D conversion ended
 1: A/D conversion in progress
 This read only flag is used to indicate when an A/D conversion process has completed. When the conversion process is running the bit will be high.

- Bit 5 **ADOFF**: ADC module power on/off control bit
 0: ADC module power on
 1: ADC module power off
- This bit controls the power to the A/D internal function. This bit should be cleared to zero to enable the A/D converter. If the bit is set high then the A/D converter will be switched off reducing the device power consumption. As the A/D converter will consume a limited amount of power, even when not executing a conversion, this may be an important consideration in power sensitive battery powered applications.
- Note: 1. it is recommended to set ADOFF=1 before entering IDLE/SLEEP Mode for saving power.
 2. ADOFF=1 will power down the ADC module.
- Bit 4 **ADRF5**: ADC Data Format Control
 0: ADC Data MSB is ADRH bit 7, LSB is ADRL bit 4
 1: ADC Data MSB is ADRH bit 3, LSB is ADRL bit 0
- This bit controls the format of the 12-bit converted A/D value in the two A/D data registers. Details are provided in the A/D data register section.
- Bit 3~0 **ACS3~ACS0**: Select A/D channel (when ACS4 is “0”)
 0000: AN0
 0001: Un-existed channel AN1, ADC input is floating
 0010: AN2
 0011: AN3
 0100: AN4
 0101: AN5(from OPA output for OCP1)
 0110: AN6
 0111: AN7
 1000: AN8 (from OPA output for OCP0)
- These are the A/D channel select control bits. As there is only one internal hardware A/D converter each of the eight A/D inputs must be routed to the internal converter using these bits.
- If bit ACS4 in the ADCR1 register is set high then the internal 1.25V will be routed to the A/D Converter.

• **ADCR1 Register**

Bit	7	6	5	4	3	2	1	0
Name	ACS4	VBGEN	—	VREFS	—	ADCK2	ADCK1	ADCK0
R/W	R/W	R/W	—	R/W	—	R/W	R/W	R/W
POR	0	0	—	0	—	0	0	0

- Bit 7 **ACS4**: Selecte Internal 1.25V as ADC input Control
 0: Disable
 1: Enable
- This bit enables 1.25V to be connected to the A/D converter. The VBGEN bit must first have been set to enable the bandgap circuit 1.25V voltage to be used by the A/D converter. When the ACS4 bit is set high, the bandgap 1.25V voltage will be routed to the A/D converter and the other A/D input channels disconnected.
- Bit 6 **VBGEN**: Internal 1.25V Control
 0: Disable
 1: Enable
- This bit controls the internal Bandgap circuit on/off function to the A/D converter. When the bit is set high the bandgap 1.25V voltage can be used by the A/D converter. If 1.25V is not used by the A/D converter and the LVR/LVD function is disabled then the bandgap reference circuit will be automatically switched off to conserve power. When 1.25V is switched on for use by the A/D converter, a time t_{BG} should be allowed for the bandgap circuit to stabilise before implementing an A/D conversion.
- Bit 5 Unimplemented, read as “0”

- Bit 4 **VREFS:** Selecte ADC reference voltage
 0: Internal ADC power
 1: VREF pin
 This bit is used to select the reference voltage for the A/D converter. If the bit is high then the A/D converter reference voltage is supplied on the external VREF pin. If the pin is low then the internal reference is used which is taken from the power supply pin VDD.
- Bit 3 Unimplemented, read as “0”
- Bit 2~0 **ADCK2~ADCK0:** Select ADC clock source
 000: f_{SYS}
 001: $f_{SYS}/2$
 010: $f_{SYS}/4$
 011: $f_{SYS}/8$
 100: $f_{SYS}/16$
 101: $f_{SYS}/32$
 110: $f_{SYS}/64$
 111: Undefined
 These three bits are used to select the clock source for the A/D converter.

A/D Operation

The START bit in the ADCR0 register is used to start and reset the A/D converter. When the microcontroller sets this bit from low to high and then low again, an analog to digital conversion cycle will be initiated. When the START bit is brought from low to high but not low again, the EOCB bit in the ADCR0 register will be set high and the analog to digital converter will be reset. It is the START bit that is used to control the overall start operation of the internal analog to digital converter.

The EOCB bit in the ADCR0 register is used to indicate when the analog to digital conversion process is complete. This bit will be automatically set to “0” by the microcontroller after a conversion cycle has ended. In addition, the corresponding A/D interrupt request flag will be set in the interrupt control register, and if the interrupts are enabled, an appropriate internal interrupt signal will be generated. This A/D internal interrupt signal will direct the program flow to the associated A/D internal interrupt address for processing. If the A/D internal interrupt is disabled, the microcontroller can be used to poll the EOCB bit in the ADCR0 register to check whether it has been cleared as an alternative method of detecting the end of an A/D conversion cycle.

The clock source for the A/D converter, which originates from the system clock f_{SYS} , can be chosen to be either f_{SYS} or a subdivided version of f_{SYS} . The division ratio value is determined by the ADCK2~ADCK0 bits in the ADCR1 register.

Although the A/D clock source is determined by the system clock f_{SYS} , and by bits ADCK2~ADCK0, there are some limitations on the maximum A/D clock source speed that can be selected. As the recommended range of permissible A/D clock period, t_{ADCK} , is from 0.53 μ s to 10 μ s, care must be taken for system clock frequencies. For example, if the system clock operates at a frequency of 4MHz, the ADCK2~ADCK0 bits should not be set to 000B, 001B or 110B. Doing so will give A/D clock periods that are less than the minimum A/D clock period or greater than the maximum A/D clock period which may result in inaccurate A/D conversion values.

Refer to the following table for examples, where values marked with an asterisk * show where, depending upon the device, special care must be taken, as the values may be less than the specified minimum A/D Clock Period.

f _{sys}	A/D Clock Period (t _{ADCK})							
	ADCK2, ADCK1, ADCK0 =000 (f _{sys})	ADCK2, ADCK1, ADCK0 =001 (f _{sys} /2)	ADCK2, ADCK1, ADCK0 =010 (f _{sys} /4)	ADCK2, ADCK1, ADCK0 =011 (f _{sys} /8)	ADCK2, ADCK1, ADCK0 =100 (f _{sys} /16)	ADCK2, ADCK1, ADCK0 =101 (f _{sys} /32)	ADCK2, ADCK1, ADCK0 =110 (f _{sys} /64)	ADCK2, ADCK1, ADCK0 =111
1MHz	1μs	2μs	4μs	8μs	16μs*	32μs*	64μs*	Undefined
2MHz	500ns*	1μs	2μs	4μs	8μs	16μs*	32μs*	Undefined
4MHz	250ns*	500ns*	1μs	2μs	4μs	8μs	16μs*	Undefined
8MHz	125ns*	250ns*	500ns*	1μs	2μs	4μs	8μs	Undefined
12MHz	83ns*	167ns*	333ns*	667ns	1.33μs	2.67μs	5.33μs	Undefined
16MHz	62.5ns*	125ns*	250ns*	500ns*	1μs	2μs	4μs	Undefined
20MHz	50ns*	100ns*	200ns*	400ns*	800ns	1.6μs	3.2μs	Undefined

A/D Clock Period Examples

Controlling the power on/off function of the A/D converter circuitry is implemented using the ADOFF bit in the ADCR0 register. This bit must be zero to power on the A/D converter. When the ADOFF bit is cleared to zero to power on the A/D converter internal circuitry a certain delay, as indicated in the timing diagram, must be allowed before an A/D conversion is initiated. Even if no pins are selected for use as A/D inputs by clearing the corresponding bits in the PAPS0, PAPS1 or PCPS registers, if the ADOFF bit is zero then some power will still be consumed. In power conscious applications it is therefore recommended that the ADOFF is set high to reduce power consumption when the A/D converter function is not being used.

The reference voltage supply to the A/D Converter can be supplied from either the positive power supply pin, VDD, or from an external reference sources supplied on pin VREF. The desired selection is made using the VREFS bit. As the VREF pin is pin-shared with other functions, when the VREFS bit is set high, the VREF pin function will be selected and the other pin functions will be disabled automatically.

A/D Input Pins

All of the A/D analog input pins are pin-shared with the I/O pins as well as other functions.

The A/D converter has its own reference voltage pin, VREF, however the reference voltage can also be supplied from the power supply pin, a choice which is made through the VREFS bit in the ADCR1 register. The analog input values must not be allowed to exceed the value of VREF.

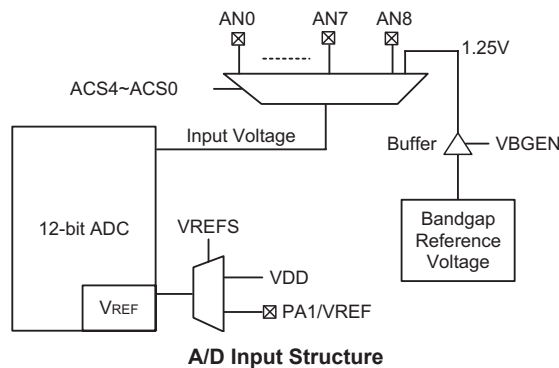

Summary of A/D Conversion Steps

The following summarises the individual steps that should be executed in order to implement an A/D conversion process.

- Step 1
Select the required A/D conversion clock by correctly programming bits ADCK2~ADCK0 in the ADCR1 register.
- Step 2
Enable the A/D by clearing the ADOFF bit in the ADCR0 register to zero.
- Step 3
Select which channel is to be connected to the internal A/D converter by correctly programming the ACS4~ACS0 bits which are also contained in the ADCR1 and ADCR0 register.
- Step 4
Select which pins are to be used as A/D inputs and configure them by correctly programming the PAPS0 / PAPS1 / PCPS registers.
- Step 5
If the interrupts are to be used, the interrupt control registers must be correctly configured to ensure the A/D converter interrupt function is active. The master interrupt control bit, EMI, and the A/D converter interrupt bit, ADE, must both be set high to do this.
- Step 6
The analog to digital conversion process can now be initialised by setting the START bit in the ADCR0 register from low to high and then low again. Note that this bit should have been originally cleared to zero.
- Step 7
To check when the analog to digital conversion process is complete, the EOCB bit in the ADCR0 register can be polled. The conversion process is complete when this bit goes low. When this occurs the A/D data registers ADRL and ADRH can be read to obtain the conversion value. As an alternative method, if the interrupts are enabled and the stack is not full, the program can wait for an A/D interrupt to occur.

Note: When checking for the end of the conversion process, if the method of polling the EOCB bit in the ADCR0 register is used, the interrupt enable step above can be omitted.

The accompanying diagram shows graphically the various stages involved in an analog to digital conversion process and its associated timing. After an A/D conversion process has been initiated by the application program, the microcontroller internal hardware will begin to carry out the conversion, during which time the program can continue with other functions. The time taken for the A/D conversion is $16 t_{ADCK}$ where t_{ADCK} is equal to the A/D clock period.

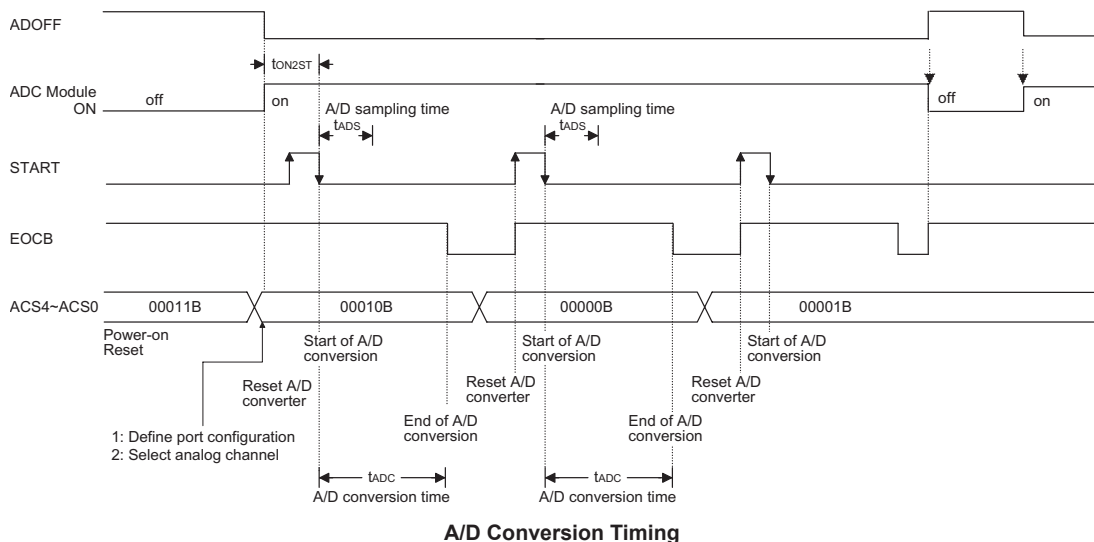

Programming Considerations

During microcontroller operations where the A/D converter is not being used, the A/D internal circuitry can be switched off to reduce power consumption, by setting bit ADOFF high in the ADCR0 register. When this happens, the internal A/D converter circuits will not consume power irrespective of what analog voltage is applied to their input lines. If the A/D converter input lines are used as normal I/Os, then care must be taken as if the input voltage is not at a valid logic level, then this may lead to some increase in power consumption.

A/D Transfer Function

As the device contains a 12-bit A/D converter, its full-scale converted digitised value is equal to FFFH. Since the full-scale analog input value is equal to the V_{DD} or V_{REF} voltage, this gives a single bit analog input value of V_{DD} or V_{REF} divided by 4096.

$$1 \text{ LSB} = (V_{DD} \text{ or } V_{REF}) / 4096$$

The A/D Converter input voltage value can be calculated using the following equation:

$$\text{A/D input voltage} = \text{A/D output digital value} \times (V_{DD} \text{ or } V_{REF}) / 4096$$

The diagram shows the ideal transfer function between the analog input value and the digitised output value for the A/D converter. Except for the digitised zero value, the subsequent digitised values will change at a point 0.5 LSB below where they would change without the offset, and the last full scale digitised value will change at a point 1.5 LSB below the V_{DD} or V_{REF} level.

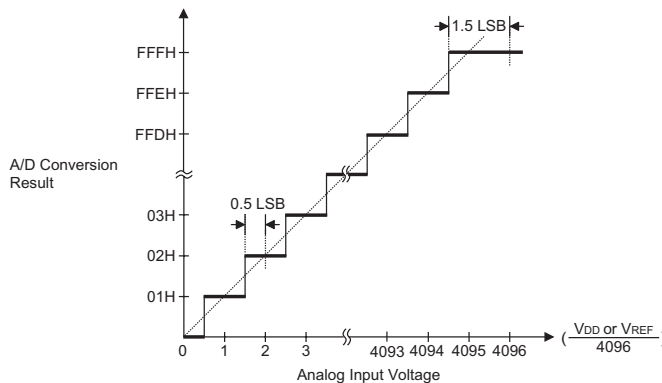

Ideal A/D Transfer Function

A/D Programming Examples

The following two programming examples illustrate how to setup and implement an A/D conversion. In the first example, the method of polling the EOCB bit in the ADCR0 register is used to detect when the conversion cycle is complete, whereas in the second example, the A/D interrupt is used to determine when the conversion is complete.

Example: using an EOCB polling method to detect the end of conversion

```

clr ADE                ; disable ADC interrupt
mov a, 03H
mov ADCR1, a           ; select fSYS/8 as A/D clock and switch off 1.25V
clr ADOFF
mov a, 51h             ; setup PAPS0 to configure pins AN0, AN2, AN3
mov PAPS0, a
mov a, 01h
mov ADCR0, a          ; enable and connect AN0 channel to A/D converter
:
start_conversion:
clr START              ; high pulse on start bit to initiate conversion
set START              ; reset A/D
clr START              ; start A/D
polling_EOC:
sz EOCB                ; poll the ADCR0 register EOCB bit to detect end of A/D conversion
jmp polling_EOC        ; continue polling
mov a, ADRL            ; read low byte conversion result value
mov ADRL_buffer, a    ; save result to user defined register
mov a, ADRH            ; read high byte conversion result value
mov ADRH_buffer, a    ; save result to user defined register
:
:
jmp start_conversion   ; start next a/d conversion

```

Example: using the interrupt method to detect the end of conversion

```
clr ADE                ; disable ADC interrupt
mov a, 03H
mov ADCR1, a           ; select fsys/8 as A/D clock and switch off 1.25V
Clr ADOFF
mov a, 51h             ; setup PAPS0 to configure pins AN0, AN2, AN3
mov PAPS0, a
mov a, 01h
mov ADCR0, a          ; enable and connect AN0 channel to A/D converter
Start_conversion:
clr START              ; high pulse on START bit to initiate conversion
set START              ; reset A/D
clr START              ; start A/D
clr ADF                ; clear ADC interrupt request flag
set ADE                ; enable ADC interrupt
set EMI                ; enable global interrupt
:
:
; ADC interrupt service routine
ADC_ISR:
mov acc_stack, a      ; save ACC to user defined memory
mov a, STATUS
mov status_stack, a  ; save STATUS to user defined memory
:
:
mov a, ADRL            ; read low byte conversion result value
mov adrl_buffer, a   ; save result to user defined register
mov a, ADRH            ; read high byte conversion result value
mov adrh_buffer, a   ; save result to user defined register
:
:
EXIT_INT_ISR:
mov a, status_stack
mov STATUS, a         ; restore STATUS from user defined memory
mov a, acc_stack      ; restore ACC from user defined memory
reti
```

Complementary PWM Output

The device provides a complementary output pair of signals which can be used as a PWM driver signal. The signal is sourced from the TM1 output signal, TP1. For PMOS type upper side driving, the PWM output is an active low signal while for NMOS type lower side driving the PWM output is an active high signal. When the dead time generator is enabled by DTEN bit and a dead time, which is programmable using the DTPSC and DT bits in the CPR register, will be inserted to prevent excessive DC currents. The dead time will be inserted whenever the rising edge of the dead time generator input signal occurs. With a dead time insertion, the output signals are eventually sent out to the external power transistors.

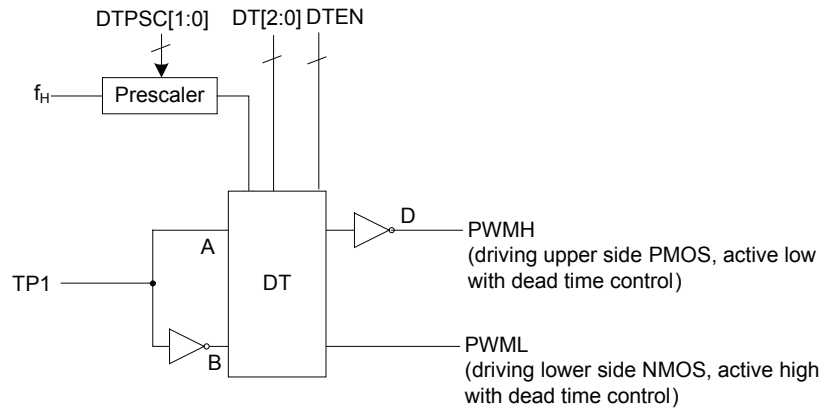

Complementary PWM Output Block Diagram

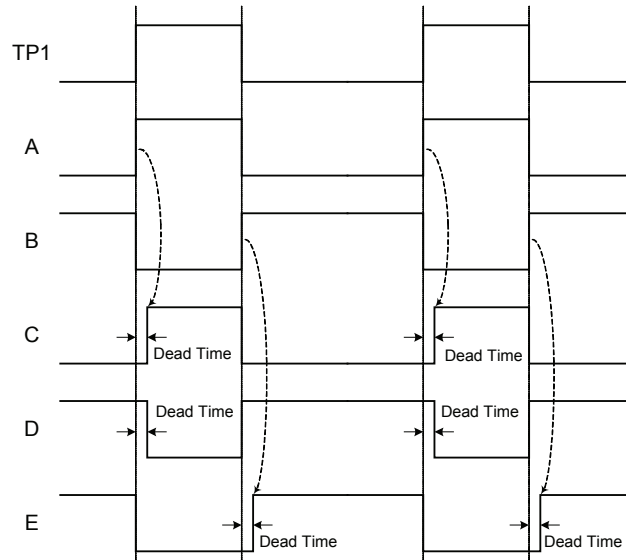

Complementary PWM Output Waveform

Note: 1. If the PB4/PB5 pin-shared functions select OUTH/OUTL:

DTEN = 1, PWMH waveform = D

DTEN = 1, PWML waveform = E

DTEN = 0, PWMH & PWML waveform = TP1

2. If the PB4/PB5 pin-shared function selects PB4/PB5, then there will not output PWM signal, it will be used as I/O function.

CPR Register

Bit	7	6	5	4	3	2	1	0
Name	DTEN	—	—	DTPSC1	DTPSC0	DT2	DT1	DT0
R/W	R/W	—	—	R/W	R/W	R/W	R/W	R/W
POR	0	—	—	0	0	0	0	0

Bit 7 **DTEN:** Dead time enable

0: Disable

1: Enable

Bit 6~5 Unimplemented, read as “0”

Bit 4~3 **DTPSC1~DTPSC0:** Dead time prescaler division ratio select

00: $f_D = f_H / 1$

01: $f_D = f_H / 2$

10: $f_D = f_H / 4$

11: $f_D = f_H / 8$

Bit 2~0 **DT2~DT0:** Dead time select

000: Dead time is $[(1/f_D) - (1/f_H)] \sim (1/f_D)$

001: Dead time is $[(2/f_D) - (1/f_H)] \sim (2/f_D)$

010: Dead time is $[(3/f_D) - (1/f_H)] \sim (3/f_D)$

011: Dead time is $[(4/f_D) - (1/f_H)] \sim (4/f_D)$

100: Dead time is $[(5/f_D) - (1/f_H)] \sim (5/f_D)$

101: Dead time is $[(6/f_D) - (1/f_H)] \sim (6/f_D)$

110: Dead time is $[(7/f_D) - (1/f_H)] \sim (7/f_D)$

111: Dead time is $[(8/f_D) - (1/f_H)] \sim (8/f_D)$

$f_H = 30\text{MHz}$	Unit: μs							
	1	2	3	4	5	6	7	8
$f_H / 1$	0.0333	0.0667	0.1000	0.1333	0.1667	0.2000	0.2333	0.2667
$f_H / 2$	0.0667	0.1333	0.2000	0.2667	0.3333	0.4000	0.4667	0.5333
$f_H / 4$	0.1333	0.2667	0.4000	0.5333	0.6667	0.8000	0.9333	1.0667
$f_H / 8$	0.2667	0.5333	0.8000	1.0667	1.3333	1.6000	1.8666	2.1333

Over Current Protection

The device is build-in with the over current protection which can be used for the application of battery charge/discharge.

OCP0/OCP1 Function

To prevent the possibility of large battery currents, the OCP input voltage from the battery sense resistor is compared with a reference voltage generated by an 8-bit D/A converter. Once the OCP input voltage is greater than the reference voltage, it will force the OUTH and OUTL signals inactive, i.e., the OUTH signal will be forced into a high state and the OUTL signal will be forced into a low state when OUTHN/OUTLN is set to "00", to turn the external MOS off for over current protection.

The OUTH and OUTL signals can be forced to an inactive state when an over current event occurs. If an over current event occurs, the corresponding interrupt will be generated. Once over current condition has disappeared, the OUTH and OUTL signals will recover to drive the PWM output.

The operational amplifier in the over current protection circuitry can be configured in an inverting or non-inverting to sense the battery current when the battery is undergoing a charge or discharge operation. It is recommended that the OPA should be in a non-inverting mode during a charge operation and in an inverting mode during a discharge operation.

Care must be taken that the OUTL/OUTH inverting output or non-inverting output is controlled by OUTLN /OUTHN bits in the TMPC register.

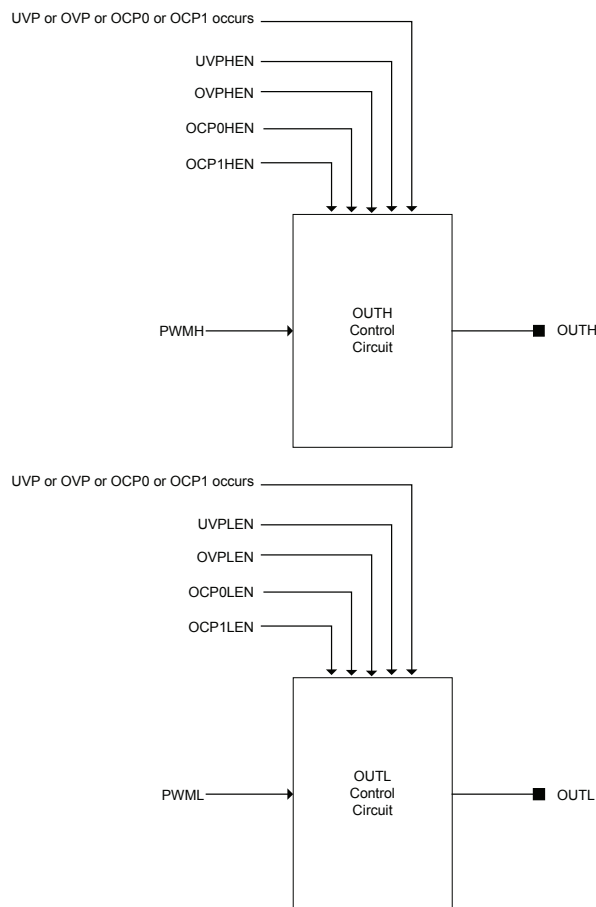

OCP input pin can be selected by PA3/PA4/PA5 pin-shared control registers.

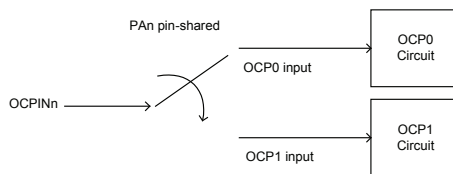

OCPINn:

- OCPIN0 is pin-shared with PA3.
- OCPIN1 is pin-shared with PA4.
- OCPIN2 is pin-shared with PA5.

The user must note that same OCP input can not select two different OCPIN input pins.

OCP0 / OCP1 DAC reference voltage comes from VREF pin.

Note: OCP internal OPA R1=20K

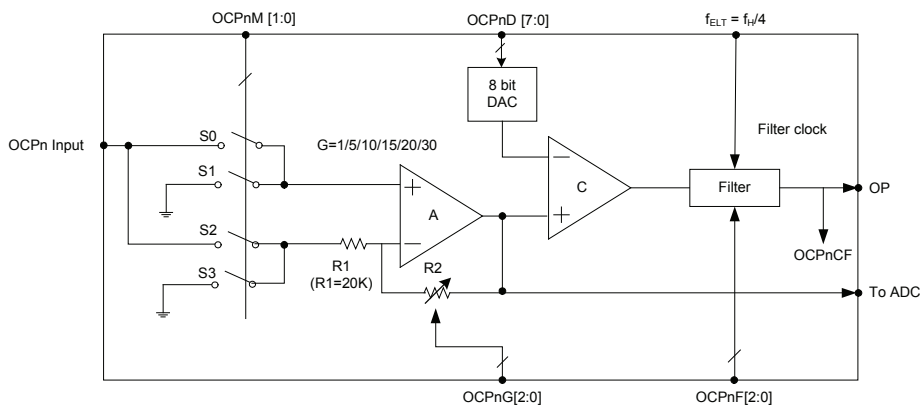

Over Current Protection Block Diagram

OCP0 and OCP1 Control Registers

Overall operation of the over current is controlled using several registers. The OCPC and OCPnC1 registers are the OCPn control registers which control the OCPn operation mode, PGA and filter functions. OCPnDA register is used to provide a DAC reference voltage for the over current protection. AnCAL and CnCAL are used to cancel out the operational amplifier and comparator input offset. For a more detailed description regarding the input offset voltage cancellation procedures, refer to the corresponding application notes on the Holtek website.

Register Name	Bit							
	7	6	5	4	3	2	1	0
OCPC	OCP0M1	OCP0M0	OCP1M1	OCP1M0	OCP1LEN	OCP1HEN	OCP0LEN	OCP0HEN
OCP0C1	OCP0O	OCP0CHY	OCP0G2	OCP0G1	OCP0G0	OCP0F2	OCP0F1	OCP0F0
OCP0DA	D7	D6	D5	D4	D3	D2	D1	D0
A0CAL	A0OFM	A0RS	A0OF5	A0OF4	A0OF3	A0OF2	A0OF1	A0OF0
C0CAL	OCP0CX	C0OFM	C0RS	C0OF4	C0OF3	C0OF2	C0OF1	C0OF0
OCP1C1	OCP1O	OCP1CHY	OCP1G2	OCP1G1	OCP1G0	OCP1F2	OCP1F1	OCP1F0
OCP1DA	D7	D6	D5	D4	D3	D2	D1	D0
A1CAL	A1OFM	A1RS	A1OF5	A1OF4	A1OF3	A1OF2	A1OF1	A1OF0
C1CAL	OCP1CX	C1OFM	C1RS	C1OF4	C1OF3	C1OF2	C1OF1	C1OF0

OCP0 and OCP1 Register List

OCPC Register

Bit	7	6	5	4	3	2	1	0
Name	OCP0M1	OCP0M0	OCP1M1	OCP1M0	OCP1LEN	OCP1HEN	OCP0LEN	OCP0HEN
R/W	R/W	R/W	R/W	R/W	R/W	R/W	R/W	R/W
POR	0	0	0	0	0	0	0	0

- Bit 7~6 **OCP0M1~OCP0M0:** OCP0 operating mode selection
 00: OCP 0 disable, S1, S3 on, S0, S2 off (OCP0 without power consumption)
 01: OCP 0 enable in non-inverter mode, S0, S3 on, S1, S2 off
 10: OCP 0 enable in inverter mode, S1, S2 on, S0, S3 off
 11: OCP 0 enable in internal 0V input mode, S1, S3 on, S0, S2 off
- Bit 5~4 **OCP1M1~OCP0M1:** OCP1 operating mode selection
 00: OCP1 disable, S1, S3 on, S0, S2 off (OCP1 without power consumption)
 01: OCP1 enable in non-inverter mode, S0, S3 on, S1, S2 off
 10: OCP1 enable in inverter mode, S1, S2 on, S0, S3 off
 11: OCP1 enable in internal 0V input mode, S1, S3 on, S0, S2 off
- Bit 3 **OCPILEN:** OUTL Over Current Protection 1 Enable control
 0: Disable
 1: Enable
 This bit is used to control whether the OUTL signal is forced into an inactive state when an over current condition occurs.
- Bit 2 **OCPIHEN:** OUTH Over Current Protection 1 Enable control
 0: Disable
 1: Enable
 This bit is used to control whether the OUTH signal is forced into an inactive state when an over current condition occurs.
- Bit 1 **OCP0LEN:** OUTL Over Current Protection 0 Enable control
 0: Disable
 1: Enable
 This bit is used to control whether the OUTL signal is forced into an inactive state when an over current condition occurs.
- Bit 0 **OCPOHEN:** OUTH Over Current Protection 0 Enable control
 OUTH Over Current Protection 0 Enable control
 0: Disable
 1: Enable
 This bit is used to control whether the OUTH signal is forced into an inactive state when an over current condition occurs.

OCP0C1 Register

Bit	7	6	5	4	3	2	1	0
Name	OCP00	OCP0CHY	OCP0G2	OCP0G1	OCP0G0	OCP0F2	OCP0F1	OCP0F0
R/W	R	R/W	R/W	R/W	R/W	R/W	R/W	R/W
POR	x	0	0	0	0	0	0	0

"x": unknown

- Bit 7 **OCP00:** Over Current Protection 0 Comparator Filter Digital Output
0: the monitored source current is not over
1: the monitored source current is over
- Bit 6 **OCP0CHY:** Over Current Protection 0 Comparator Hysteresis Enable control
0: Disable
1: Enable
- Bit 5~3 **OCP0G2~OCP0G0:** Over Current Protection 0 OPA gain selection
000: ×1
001: ×5
010: ×10
011: ×15
100: ×20
101: ×30
110: ×30
111: ×30
- Bit 2~0 **OCP0F2~OCP0F0:** Over Current Protection 0 demodulation filter selection
000: 0 t_{FLT} (without filter)
001: 1~2 × t_{FLT}
010: 3~4 × t_{FLT}
011: 7~8 × t_{FLT}
100: 15~16 × t_{FLT}
101: 31~32 × t_{FLT}
110: 63~64 × t_{FLT}
111: 127~128 × t_{FLT}
Note: $f_{FLT}=f_H/4, t_{FLT}=1/f_{FLT}$

OCP0DA Register

Bit	7	6	5	4	3	2	1	0
Name	D7	D6	D5	D4	D3	D2	D1	D0
R/W	R/W	R/W	R/W	R/W	R/W	R/W	R/W	R/W
POR	0	0	0	0	0	0	0	0

- Bit 7~0 OCP 0 DAC Data Register bit 7 ~ bit 0
8-bit DAC data bits.
OCP 0 DAC Output = (DAC reference voltage) × (DAC.7~0)/256

A0CAL Register

Bit	7	6	5	4	3	2	1	0
Name	A0OFM	A0RS	A0OF5	A0OF4	A0OF3	A0OF2	A0OF1	A0OF0
R/W	R/W	R/W	R/W	R/W	R/W	R/W	R/W	R/W
POR	0	0	1	0	0	0	0	0

- Bit 7 **A0OFM**: Over Current Protection 0 Operational Amplifier Input Offset Voltage Cancellation Mode Select
 0: Operational Amplifier mode
 1: Input Offset Voltage Cancellation mode
 Note: It will enter Input Offset Voltage Cancellation mode only when OCP0M1~OCP0M0 bits are set to "11".
- Bit 6 **A0RS**: Over Current Protection 0 Operational Amplifier Offset Voltage Cancellation Reference Input Select
 0: Operational Amplifier negative input selected
 1: Operational Amplifier positive input selected
- Bit 5~0 **A0OF5~A0OF0**: Over Current Protection 0 Operational Amplifier Input Voltage Offset Cancellation Setting

C0CAL Register

Bit	7	6	5	4	3	2	1	0
Name	OCP0CX	C0OFM	C0RS	C0OF4	C0OF3	C0OF2	C0OF1	C0OF0
R/W	R	R/W	R/W	R/W	R/W	R/W	R/W	R/W
POR	x	0	0	1	0	0	0	0

"x": unknown

- Bit 7 **OCP0CX**: Over Current Protection 0 Comparator or Operational Amplifier Digital Output for Input Offset Voltage Cancellation mode
 0: Positive input voltage < Negative input voltage
 1: Positive input voltage > Negative input voltage
- Bit 6 **C0OFM**: Over Current Protection 0 Comparator Input Offset Voltage Cancellation Mode Select
 0: Comparator mode
 1: Input Offset Voltage Cancellation mode
 Note: It will enter Input Offset Voltage Cancellation mode only when OCP0M1~OCP0M0 bits are set to "11".
- Bit 5 **C0RS**: Over Current Protection 0 Comparator Offset Voltage Cancellation Reference Input Select
 0: Comparator negative input selected
 1: Comparator positive input selected
- bit 4~0 **C0OF3~C0OF0**: Over Current Protection 0 Comparator Input Voltage Offset Cancellation Setting

OCP1C1 Register

Bit	7	6	5	4	3	2	1	0
Name	OCP1O	OCP1CHY	OCP1G2	OCP1G1	OCP1G0	OCP1F2	OCP1F1	OCP1F0
R/W	R	R/W	R/W	R/W	R/W	R/W	R/W	R/W
POR	x	0	0	0	0	0	0	0

"x": unknown

- Bit 7 **OCP1O:** Over Current Protection 1 Comparator Filter Digital Output
 0: The monitored source current is not over
 1: The monitored source current is over
- Bit 6 **OCP1CHY:** Over Current Protection 1 Comparator Hysteresis Enable control
 0: Disable
 1: Enable
- Bit 5~3 **OCP1G2~OCP1G0:** Over Current Protection 1 OPA gain selection
 000: ×1
 001: ×5
 010: ×10
 011: ×15
 100: ×20
 101: ×30
 110: ×30
 111: ×30
- Bit 2~0 **OCP1F2~OCP1F0:** Over Current Protection 1 demodulation filter selection
 000: 0 t_{FLT} (without filter)
 001: 1~2 × t_{FLT}
 010: 3~4 × t_{FLT}
 011: 7~8 × t_{FLT}
 100: 15~16 × t_{FLT}
 101: 31~32 × t_{FLT}
 110: 63~64 × t_{FLT}
 111: 127~128 × t_{FLT}
 Note: $f_{FLT}=f_H/4$, $t_{FLT}=1/f_{FLT}$

OCP1DA Register

Bit	7	6	5	4	3	2	1	0
Name	D7	D6	D5	D4	D3	D2	D1	D0
R/W	R/W	R/W	R/W	R/W	R/W	R/W	R/W	R/W
POR	0	0	0	0	0	0	0	0

- Bit 7 OCP 1 DAC Data Register bit 7 ~ bit 0
 8-bit DAC data bits.
 OCP 1 DAC Output = (DAC reference voltage) × (DAC.7~0)/256

A1CAL Register

Bit	7	6	5	4	3	2	1	0
Name	A1OFM	A1RS	A1OF5	A1OF4	A1OF3	A1OF2	A1OF1	A1OF0
R/W	R/W	R/W	R/W	R/W	R/W	R/W	R/W	R/W
POR	0	0	1	0	0	0	0	0

- Bit 7 **A1OFM**: Over Current Protection 1 Operational Amplifier Input Offset Voltage Cancellation Mode Select
 0: Operational Amplifier mode
 1: Input Offset Voltage Cancellation mode
 Note: It will enter Input Offset Voltage Cancellation mode only when OCP1M1~OCP1M0 bits are set to "11".
- Bit 6 **A1RS**: Over Current Protection1 Operational Amplifier Offset Voltage Cancellation Reference Input Select
 0: Operational Amplifier negative input selected
 1: Operational Amplifier positive input selected
- Bit 5~0 **A1OF5~A1OF0**: Over Current Protection 1 Operational Amplifier Input Voltage Offset Cancellation Setting

C1CAL Register

Bit	7	6	5	4	3	2	1	0
Name	OCP1CX	C1OFM	C1RS	C1OF4	C1OF3	C1OF2	C1OF1	C1OF0
R/W	R	R/W	R/W	R/W	R/W	R/W	R/W	R/W
POR	x	0	0	1	0	0	0	0

"x": unknown

- Bit 7 **OCP1CX**: Over Current Protection 1 Comparator or Operational Amplifier Digital Output for Input Offset Voltage Cancellation mode
 0: Positive input voltage < Negative input voltage
 1: Positive input voltage > Negative input voltage
- Bit 6 **C1OFM**: Over Current Protection 1 Comparator Input Offset Voltage Cancellation Mode Select
 0: Comparator mode
 1: Input Offset Voltage Cancellation mode
 Note: It will enter Input Offset Voltage Cancellation mode only when OCP1M1~OCP1M0 bits be set to "11".
- Bit 5 **C1RS**: Over Current Protection 1 Comparator Offset Voltage Cancellation Reference Input Select
 0: Comparator negative input selected
 1: Comparator positive input selected
- bit 4~0 **C1OF3~C1OF0**: Over Current Protection 1 Comparator Input Voltage Offset Cancellation Setting

Over Voltage Protection and Under Voltage Protection

The device is build-in with the over/under voltage protection which can be used for the application of battery charge/discharge.

- OVP function:

To prevent from output voltage greater than 5.4V, the OVP input voltage can be compared with 8-bit reference voltage. Once OVP is greater than the reference voltage, i.e., the OUTH signal will be forced into a high state and the OUTL signal will be forced into a low state if OUTHN/OUTLN is set to “00”, to turn the external MOS off for over voltage protection.

- UVP function:

To prevent from output voltage less than 1.0V (external circuit short), the UVP input voltage can be compared with 8-bit reference voltage. Once UVP is less than the reference voltage, i.e., the OUTH signal will be forced into a high state and the OUTL signal will be forced into a low state when OUTHN/OUTLN is set to “00”, to turn the external MOS off for under voltage protection..

The OUTH/OUTL can be forced as inactive state for either OVP or UVP occurs. The OVP/UVP also generates interrupt to inform MCU. Once OVP/UVP disappears, the OUTH/OUTL will recover to send PWM output.

Care must be taken that the OUTL/OUTH inverting output or non-inverting output is controlled by OUTLN/OUTHN bits in the TMPC register.

Auto-Adjust Level Trigger comes from OVPL, UVPL, while OVP/UVP DAC reference voltage comes from VREF pin.

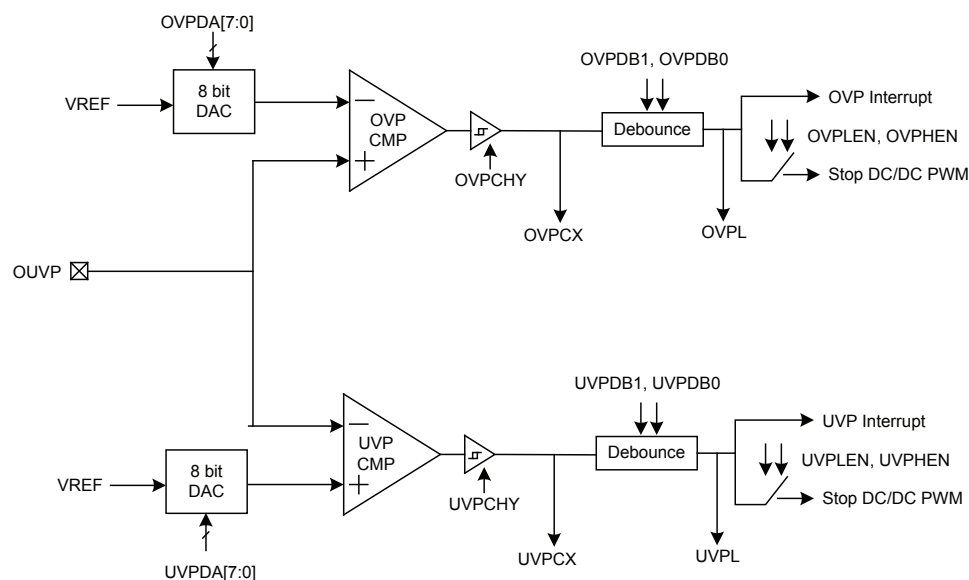

OUPV Protection Block Diagram

OUPV Control Registers

Overall operation of the over voltage or under voltage is controlled using several registers. OVPDA and UVPDA registers are used to provide the DAC reference voltage for the over voltage protection and under voltage protection. OUVPC0 and OUVPC1 registers are used to control the OUPV function, comparator digital output, comparator debounce time and the hysteresis function. OUVPC2 is the OUTH and OUTL control register during over/under voltage protection.

Register Name	Bit							
	7	6	5	4	3	2	1	0
OVPDA	D7	D6	D5	D4	D3	D2	D1	D0
UVPDA	D7	D6	D5	D4	D3	D2	D1	D0
OUVPC0	OVPCX	—	—	OVPCHY	—	—	OVPDB1	OVPDB0
OUVPC1	UVPCX	OVPEN	UVPEN	UVPCHY	—	—	UVPDB1	UVPDB0
OUVPC2	—	—	—	—	UVPLEN	UVPHEN	OVPLEN	OVPHEN

OUPV Register List

OVPDA Register

Bit	7	6	5	4	3	2	1	0
Name	D7	D6	D5	D4	D3	D2	D1	D0
R/W	R/W	R/W	R/W	R/W	R/W	R/W	R/W	R/W
POR	0	0	0	0	0	0	0	0

Bit 7~0 OVP DAC Data Register bit 7 ~ bit 0
8-bit DAC data bits.
OVP DAC Output = (DAC reference voltage) × (DAC.7~0)/256

UVPDA Register

Bit	7	6	5	4	3	2	1	0
Name	D7	D6	D5	D4	D3	D2	D1	D0
R/W	R/W	R/W	R/W	R/W	R/W	R/W	R/W	R/W
POR	0	0	0	0	0	0	0	0

Bit 7~0 UVP DAC Data Register bit 7 ~ bit 0
8-bit DAC data bits.
UVP DAC Output = (DAC reference voltage) × (DAC.7~0)/256

OUVPC0 Register

Bit	7	6	5	4	3	2	1	0
Name	OVPCX	—	—	OVPCHY	—	—	OVPDB1	OVPDB0
R/W	R	—	—	R/W	—	—	R/W	R/W
POR	x	—	—	0	—	0	0	0

"x": unknown

Bit 7 **OVPCX**: Over Voltage Protection Comparator Digital Output
0: Positive input voltage < Negative input voltage
1: Positive input voltage > Negative input voltage

Bit 6~5 Unimplemented, read as "0"

Bit 4 **OVPCHY**: Over Voltage Protection Comparator Hysteresis Enable control
0: Disable
1: Enable

Bit 3~2 Unimplemented, read as "0"

Bit 1~0 **OVPDB1~OVPDB0**: Over Voltage Protection Comparator Debounce Time Select
00: No Debounce
01: Debounce time = (7~8) × 1/f_{HI}
10: Debounce time = (15~16) × 1/f_{HI}
11: Debounce time = (31~32) × 1/f_{HI}

OUVPC1 Register

Bit	7	6	5	4	3	2	1	0
Name	UVPCX	OVPEN	UVPEN	UVPCHY	—	—	UVPDB1	UVPDB0
R/W	R	R/W	R/W	R/W	—	—	R/W	R/W
POR	x	0	0	0	—	—	0	0

"x": unknown

- Bit 7 **UVPCX:** Under Voltage Protection Comparator Digital Output
0: Positive input voltage < Negative input voltage
1: Ppositive input voltage > Negative input voltage
- Bit 6 **OVPEN:** Over Voltage Protection function Enable control
0: Disable
1: Enable
If the OVPEN bit is cleared to 0, the over voltage protection function is disabled and no power will be consumed. This results in the comparator and D/A converter of OVP all being switched off.
- Bit 5 **UVPEN:** Under Voltage Protection function Enable control
0: Disable
1: Enable
If the UVPEN bit is cleared to 0, the under voltage protection function is disabled and no power will be consumed. This results in the comparator and D/A converter of UVP all being switched off.
- Bit 4 **UVPCHY:** Under Voltage Protection Comparator Hysteresis Enable control
0: Disable
1: Enable
- Bit 3~2 Unimplemented, read as “0”
- Bit 1~0 **UVPDB1~UVPDB0:** Under Voltage Protection Comparator Debounce Time Select
00: No debounce
01: Debounce time = $(7\sim 8) \times 1/f_H$
10: Debounce time = $(15\sim 16) \times 1/f_H$
11: Debounce time = $(31\sim 32) \times 1/f_H$

OUVPC2 Register

Bit	7	6	5	4	3	2	1	0
Name	—	—	—	—	UVPLEN	UVPHEN	OVPLEN	OVPHEN
R/W	—	—	—	—	R/W	R/W	R/W	R/W
POR	—	—	—	—	0	0	0	0

- Bit 7~4 Unimplemented, read as “0”
- Bit 3 **UVPLEN:** OUTL Under Voltage Protection Enable control
0: Disable
1: Enable
This bit is used to control whether the OUTL signal is forced into an inactive state when an under voltage condition occurs.
- Bit 2 **UVPHEN:** OUTH Under Voltage Protection Enable control
0: Disable
1: Enable
This bit is used to control whether the OUTH signal is forced into an inactive state when an under voltage condition occurs.
- Bit 1 **OVPLEN:** OUTL Over Voltage Protection Enable control
0: Disable
1: Enable
This bit is used to control whether the OUTL signal is forced into an inactive state when an over voltage condition occurs.
- Bit 0 **OVPHEN:** OUTH Over Voltage Protection Enable control
0: Disable
1: Enable
This bit is used to control whether the OUTH signal is forced into an inactive state when an over voltage condition occurs.

Auto-adjust PWM

In order to increase the DC-DC response speed, the device provides a specific circuit together with PTM (TM1) and OUVP function for automatically adjusting DC-DC output effect.

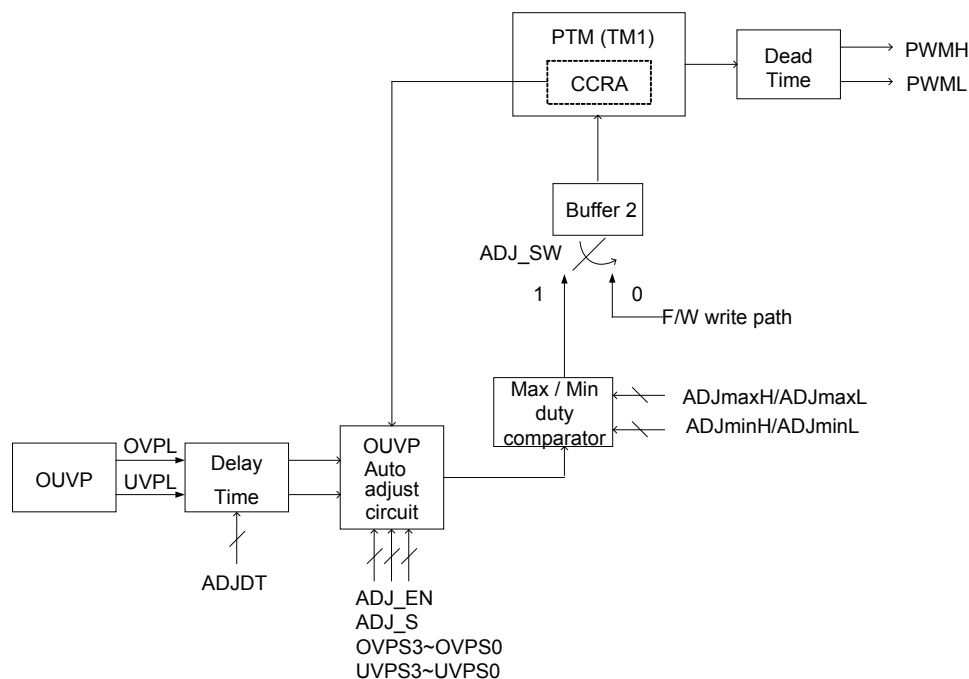

Auto-adjust DC-DC Block Diagram

Note: Users must finish setting the auto-adjust PWM registers when ADJ_EN bit is equal to 0. Changing the corresponding registers value after ADJ_EN bit is set to 1, which will easily cause the Auto-adjust PWM function misoperations due to timing problems.

Operation steps are shown below:

1. ADJ_EN = 0, disable the auto-adjust circuit to initialize the program.
 - a. Max/Min Duty setting (10-bit). Note: $1 < \text{Min} < \text{TM1_CCRA} < \text{MAX}$
 - b. Set delay time (4-bit: take PTM cycle as the time base) after every trigger.
 - c. Set the duty adjust action(increase or decrease) when OUVP occurs
 - d. Set the auto-adjust duty step (0~15) when OUVP occurs
 - e. OUVP voltage setting $\rightarrow \text{UVP} < \text{Target Voltage} < \text{OVP}$
(Eg. Target Voltage = 5V, UVP = 4.85V, OVP = 5.15V)
2. DC-DC S/W Start:
 - a. PTM Initialization
 - ♦ PWM mode
 - ♦ PTM counter clear condition is CCRP match
 - ♦ CCRA initialization
 - b. Start PWM output, enable the boost circuit
 - c. Read the OUVP value then adjust the duty to make the Output Voltage=Target Voltage
3. ADJ_EN = 1, enable the auto-adjust circuit
4. If the UVP interrupt occurs, then by looking at the time delay which is obtained by UVP+OCP comparator output along with F/W, determine UVP is caused by adding load instantaneously or by external equipment short-circuit.

5. If the OVP interrupt occurs, then by looking at the time delay which is obtained by OVP comparator output along with F/W, determine OVP is caused by reducing load instantaneously or by unnormal operation of the DC-DC circuit

ADJBH / ADJBL represents Buffer 2,

When ADJ_EN=1 & ADJ_SW=0, Buffer2=TM1_CCRA, F/W selects TM1_CCRA to write into Buffer2,

When ADJ_EN=0, the auto-adjust function will be disabled, Buffer2=0

When the PTM (TM1) T1ON=1, if the value is written into Buffer2, then the CCRA will update until the TM1 counter is equal to “0”.

1. OVPL/UVPL Level Trigger auto-adjust circuit.
2. OVPL/UVPL Edge trigger MCU Interrupt.
3. OVP/UVPL comparator output can be used as the F/W determination.
4. F/W can not change the duty value (Double Buffer) during automatical adjustment.

Auto-adjust PWM Control Registers

Auto-adjust PWM function is controlled using several registers. ADJDT and ADJS registers are used to set the auto-adjust PWM delay time and the auto-adjust PWM duty step respectively. ADJC register is used to control the adjustment PWM function. ADJMaxH and ADJMaxL registers are used to store the auto-adjust PWM max duty data. ADJMinH and ADJMinL registers are used to store the auto-adjust PWM min duty data. ADJBH and ADJBL registers are used to store the auto-adjust PWM Buffer2 duty data.

Register Name	Bit							
	7	6	5	4	3	2	1	0
ADJDT	—	—	D5	D4	D3	D2	D1	D0
ADJS	OVPS3	OVPS2	OVPS1	OVPS0	UVPS3	UVPS2	UVPS1	UVPS0
ADJC	ADJ_En	ADJ_S	ADJ_SW	—	OVPL	UVPL	OCP1CF	OCP0CF
ADJMaxH	—	—	—	—	—	—	D9	D8
ADJMaxL	D7	D6	D5	D4	D3	D2	D1	D0
ADJMinH	—	—	—	—	—	—	D9	D8
ADJMinL	D7	D6	D5	D4	D3	D2	D1	D0
ADJBH	—	—	—	—	—	—	D9	D8
ADJBL	D7	D6	D5	D4	D3	D2	D1	D0

Auto-adjust DC-DC Register List

ADJDT Register

Bit	7	6	5	4	3	2	1	0
Name	—	—	D5	D4	D3	D2	D1	D0
R/W	—	—	R/W	R/W	R/W	R/W	R/W	R/W
POR	—	—	0	0	0	0	0	0

Bit 7~6 Unimplemented, read as “0”

Bit 5~0 **D5~D0**: Auto-Adjust PWM delay time
 $N=ADJDT[5:0]$, delay time= $(N+1) \times PTM\ Cycle \times 2$
 000000: delay time is $PTM\ Cycle \times 2$
 000001: delay time is $PTM\ Cycle \times 4$
 ~
 111111: delay time is $PTM\ Cycle \times 128$

Note: As PTM is asynchronous with CPU, when the auto-adjust trigger is enabled, then the second auto-adjusta function may have a cycle deviation, it will take two automatically adjustment cycles for stabilization.

Eg:

ADJDT=1 (4 cycles automatically adjust once)

When OVPL=1, the auto-adjust function will be enabled to trigger auto-adjust function, it is at Cycle 1 now. In theory, Cycle 4 needs to restart the auto-adjust function. But the auto-adjust function will be possible started at Cycle 3 or Cycle 4 or Cycle 5, the next auto-adjust function will start at Cycle 8 according to ADJDT bit setting

ADJS Register

Bit	7	6	5	4	3	2	1	0
Name	OVPS3	OVPS2	OVPS1	OVPS0	UVPS3	UVPS2	UVPS1	UVPS0
R/W	R/W	R/W	R/W	R/W	R/W	R/W	R/W	R/W
POR	0	0	0	0	0	0	0	0

Bit 7~4 **OVPS3~OVPS0**: OVP auto adjust PWM Duty step
 0000: 0 step ~ 1111: 15 step

Bit 3~0 **UVPS3~UVPS0**: UVP auto adjust PWM Duty step
 0000: 0 step ~ 1111: 15 step

ADJC Register

Bit	7	6	5	4	3	2	1	0
Name	ADJ_EN	ADJ_S	ADJ_SW	—	OVPL	UVPL	OCP1CF	OCP0CF
R/W	R/W	R/W	R/W	—	R	R	R	R
POR	0	0	0	—	x	x	x	x

"x": unknown

Bit 7 **ADJ_EN**: Auto adjust PWM Duty control bit
 0: Auto adjust PWM Duty control disable
 1: Auto adjust PWM Duty control enable

Bit 6 **ADJ_S**: Duty adjust bit
 0: OVP increase duty
 UVP decrease duty
 1: OVP decrease duty
 UVP increase duty

- Bit 5 **ADJ_SW:**
 0: F/W write data into Buffer2 through TM1_CCRA
 1: Write into Buffer2 by auto-adjust system
 When ADJ_EN=0, the auto-adjust function is disabled, then ADJ_SW bit is always 0
 When ADJ_EN=1, the auto-adjust function is enabled, if OVPL or UVPL bit is set to 1, then ADJ_SW bit will be switched to 1
 When auto adjust duty is completed, if want to set duty by F/W, then it need to switch ADJ_SW bit from 1 to 0.
 But ADJ_SW bit switching from 1 to 0 is succeed only when OVPL & UVPL are equal to 0.
- Bit 4 Unimplemented, read as “0”
- Bit 3 **OVPL:** OVP Comparator Status (After debounce)
 0: OVP Comparator output low (No over voltage occurs)
 1: OVP Comparator output high (Over voltage occurs)
- Bit 2 **UVPL:** UVP Comparator Status (After debounce)
 0: UVP Comparator output low (No under voltage occurs)
 1: UVP Comparator output high (Under voltage occurs)
- Bit 1 **OCP1CF:** OCP1 Comparator Status (After OCP1 filter)
 0: OCP1 Comparator output low (No over current occurs)
 1: OCP1 Comparator output high (Over current occurs)
- Bit 0 **OCP0CF:** OCP0 Comparator Status (After OCP0 filter)
 0: OCP0 Comparator output low (No over current occurs)
 1: OCP0 Comparator output high (Over current occurs)

ADJMaxH Register

Bit	7	6	5	4	3	2	1	0
Name	—	—	—	—	—	—	D9	D8
R/W	—	—	—	—	—	—	R/W	R/W
POR	—	—	—	—	—	—	0	0

- Bit 7~2 Unimplemented, read as “0”
- Bit 1~0 Auto-adjust PWM Max duty high byte

ADJMaxL Register

Bit	7	6	5	4	3	2	1	0
Name	D7	D6	D5	D4	D3	D2	D1	D0
R/W	R/W	R/W	R/W	R/W	R/W	R/W	R/W	R/W
POR	0	0	0	0	0	0	0	0

- Bit 7~0 Auto-adjust PWM Max duty low byte

ADJMinH Register

Bit	7	6	5	4	3	2	1	0
Name	—	—	—	—	—	—	D9	D8
R/W	—	—	—	—	—	—	R/W	R/W
POR	—	—	—	—	—	—	0	0

- Bit 7~2 Unimplemented, read as “0”
- Bit 1~0 Auto-adjust PWM Min duty high byte

ADJMinL Register

Bit	7	6	5	4	3	2	1	0
Name	D7	D6	D5	D4	D3	D2	D1	D0
R/W	R/W	R/W	R/W	R/W	R/W	R/W	R/W	R/W
POR	0	0	0	0	0	0	0	0

Bit 7~0 Auto-adjust PWM Min duty low byte

ADJBH Register

Bit	7	6	5	4	3	2	1	0
Name	—	—	—	—	—	—	D9	D8
R/W	—	—	—	—	—	—	R	R
POR	—	—	—	—	—	—	0	0

Bit 7~2 Unimplemented, read as “0”

Bit 1~0 Auto-adjust PWM Buffer2 duty high byte

ADJBL Register

Bit	7	6	5	4	3	2	1	0
Name	D7	D6	D5	D4	D3	D2	D1	D0
R/W	R	R	R	R	R	R	R	R
POR	0	0	0	0	0	0	0	0

Bit 7~0 Auto-adjust PWM Buffer2 duty low byte

Integrated Divider Resistor and Internal Switch

In order to reduce customer overall product price, this device has integrated the external divider resistor to internal IC, and some switches can be on/off by setting S/W. As the integrated resistor does not have capacitor to filter noise, which will result in making an error on reading ADC value, so the switch is reserved to short internal resistor circuit.

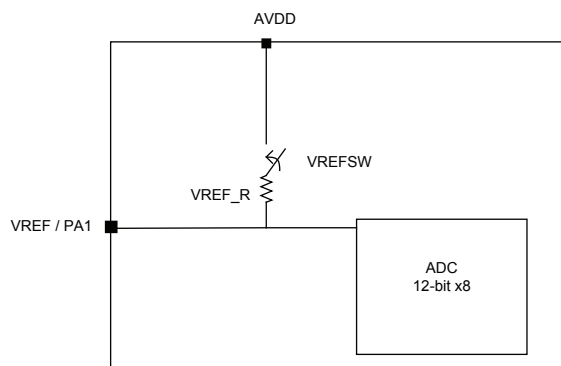

VREF Pin internal Divider Resistor and Switch Circuit

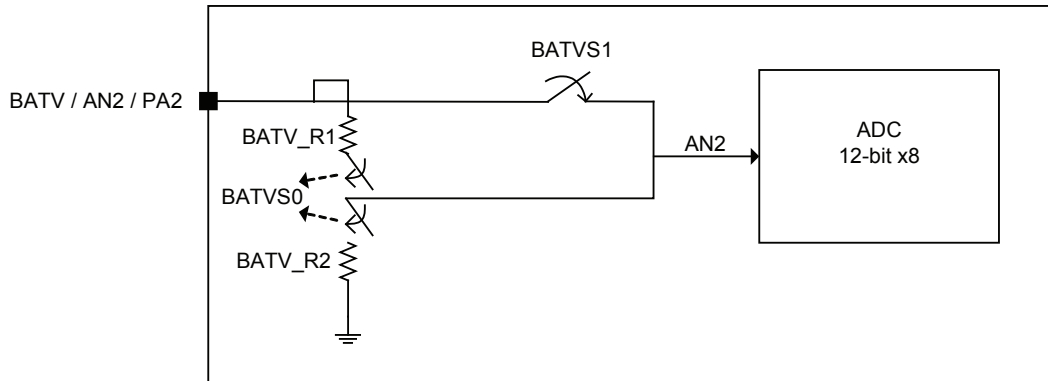

BATV Pin internal Divider Resistor and Switch Circuit

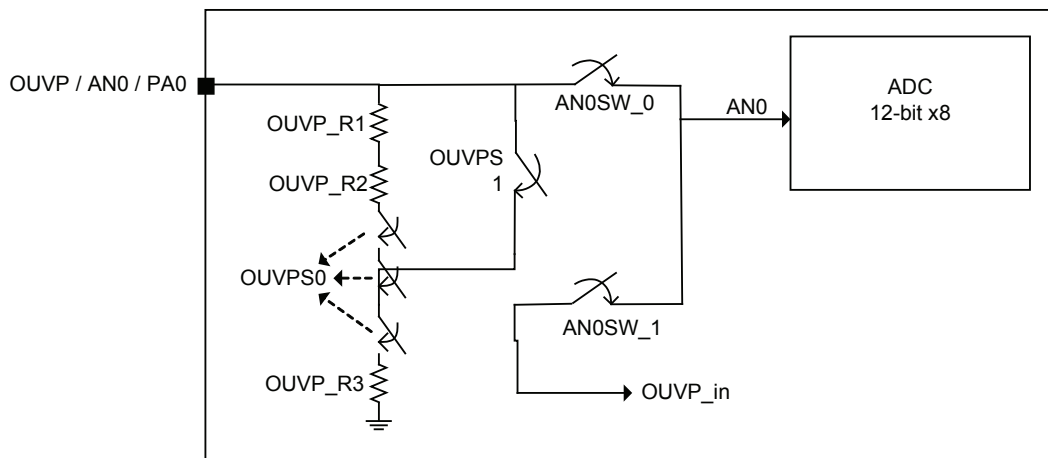

OUVP Pin internal Divider Resistor and Switch Circuit

- PA1/VREF pin internally has a 1K (min: 0.7K / max: 1.2K) Pull-high resistor VREF_R (VREFS can be used as a switch)
- BATV pin has two integrated divider resistors, BATV_R1:BATV_R2=1:1, the resistance value is 20K:20K. The accuracy of this scale must be up to 1%. BATV_R1+BATV_R2=40K, this resistance value can have a tolerance of 50%. Additionally, the separate switch (BATVS0) controls two switches at the same time to reach this accuracy.
- OUVP pin has two integrated divider resistors, (OUVP_R1+OUVP_R2):OUVP_R3=2:1, the resistance value is 2K:1K. The accuracy of this scale must be up to 1%. OUVV_R1+OUVP_R2+OUVP_R3=3K, this resistance value can have a tolerance of 50%. Additionally, the separate switch (OUVPS0) controls three switches at the same time to reach this accuracy.

If the integrated resistor does not have capacitor to filter the noise, such as the B/C mentioned above, then the reserved switches (OUVPS1 & AN0SW & BATVS1) can use external divider resistor.

Internal Switch Set Register – SWS

A single register, SWS, controls the internal divider resistor of the VREF, BATV and OUVV pins connection function.

SWS Register

Bit	7	6	5	4	3	2	1	0
Name	—	—	VREFSW	BATVS1	BATVS0	AN0SW	OUVPS1	OUVPS0
R/W	—	—	R/W	R/W	R/W	R/W	R/W	R/W
POR	—	—	0	0	0	0	0	0

- Bit 7~6 Unimplemented, read as “0”
- Bit 5 **VREFSW**: Integrated 1K resistance VREF_R and VDD short circuit control:
 0: Integrated resistance VREF_R and VDD are not connected together
 1: Integrated resistance VREF_R and VDD are connected together
 Note: Only when PA1S1~PA1S0 are equal to 10, setting VREFSW bit in the SWS register to 1 can connected VREF_R and VDD together.
- Bit 4 **BATVS1**: Bypass integrated divider resistor control:
 0: BATV and AD_input (AN2) are connected by BATV_R1
 1: BATV and AD_input (AN2) are shorted (use external divider resistor)
- Bit 3 **BATVS0**: integrated divider resistor BATV_R2 and GND short circuit control:
 0: Divider resistor BATV_R1 and BATV_R2 are not connected together
 1: Divider resistor BATV_R1 and BATV_R2 are connected together
 Note: Only when PA2S1~PA2S0 bits are equal to 01 and ACS3~ACS0 bits select AN2 as ADC input, setting the BATVS1~BATVS0 bits in the SWS register to 11 can connected BATV_R1 and BATV_R2 together.
- Bit 2 **AN0SW**: AN0 input select:
 0: AN0SW_0 enable / AN0SW_1 disable, AN0 and PA0 are connected directly
 1: AN0SW_0 disable / AN0SW_1 enable, AN0 and PA0 are connected by OUVV_R1/R2
 Note: Only when PA0S1~PA0S0 bits are equal to 01 and ACS3~ACS0 bits select AN0 as ADC input, then AN0SW bit can function, otherwise, it will be open circuit.
- Bit 1 **OUVPS1**: Bypass integrated divider resistor control
 0: OUVV input are connected by OUVV_R1/R2
 1: OUVV input and PA0 pin short circuit (use external divider resistor)
 Note: When PA0S1~PA0S0 are equal to 01, then the setting of OUVPS1 bit can function, otherwise they are all open circuit.
- Bit 0 **OUVPS0**: integrated divider resistor OUVV_R2 and OUVV_R3 short circuit control:
 0: Divider resistor OUVV_R2 and OUVV_R3 are not connected together
 1: Divider resistor OUVV_R2 and OUVV_R3 are connected together
 Note: When PA0S1~PA0S0 bits are equal to 01, then the setting of OUVPS1~OUVPS0 bits in the SWS register can connect OUVV_R2 and OUVV_R3 together.

Note that, the OUVPS0/OUVPS1/AN0SW registers should have correct setting.

If it is need to use internal divider resistor, then the setting is as follows:

OUVPS0=1 / OUVPS1=0 / AN0SW=1

If it is need to use external divider resistor, then the setting is as follows:

OUVPS0=0 / OUVPS1=1 / AN0SW=0

Otherwise, incorrectly setting these registers will lead AN0/OUVV input to abnormal operation.

Interrupts

Interrupts are an important part of any microcontroller system. When an external event or an internal function such as a Timer Module or an A/D converter requires microcontroller attention, their corresponding interrupt will enforce a temporary suspension of the main program allowing the microcontroller to direct attention to their respective needs. The device contains several external interrupt and internal interrupts functions. The external interrupt is generated by the action of the external INT0 and INT1 pins, while the internal interrupts are generated by various internal functions such as the TMs, OCP, OVP, UVP, Time Base, LVD, EEPROM and the A/D converter.

Interrupt Registers

Overall interrupt control, which basically means the setting of request flags when certain microcontroller conditions occur and the setting of interrupt enable bits by the application program, is controlled by a series of registers, located in the Special Purpose Data Memory, as shown in the accompanying table. The number of registers depends upon the device chosen but fall into three categories. The first is the INTC0~INTC3 registers which setup the primary interrupts, the second is the MFI0~MFI2 registers which setup the Multi-function interrupts. Finally there is an INTEG register to setup the external interrupt trigger edge type.

Each register contains a number of enable bits to enable or disable individual registers as well as interrupt flags to indicate the presence of an interrupt request. The naming convention of these follows a specific pattern. First is listed an abbreviated interrupt type, then the (optional) number of that interrupt followed by either an “E” for enable/disable bit or “F” for request flag.

Function	Enable Bit	Request Flag	Notes
Global	EMI	—	—
INTn Pin	INTnE	INTnF	n=0 or 1
OVP	OVPE	OVPF	—
UVP	UVPE	UVPE	—
OCP	OCPnE	OCPnF	n=0 or 1
A/D Converter	ADE	ADF	—
Multi-function	MFnE	MFnF	n=0~2
Time Base	TBnE	TBnF	n=0 or 1
LVD	LVE	LVF	—
EEPROM	DEE	DEF	—
TM	TnPE	TnPF	n=0~2
	TnAE	TnAF	

Interrupt Register Bit Naming Conventions

Register Name	Bit							
	7	6	5	4	3	2	1	0
INTEG	—	—	—	—	INT1S1	INT1S0	INT0S1	INT0S0
INTC0	—	OVPF	OCP1F	OCP0F	OVPE	OCP1E	OCP0E	EMI
INTC1	MF0F	INT1F	INT0F	UVPF	MF0E	INT1E	INT0E	UVPE
INTC2	TB0F	LVF	MF2F	MF1F	TB0E	LVE	MF2E	MF1E
INTC3	—	—	ADF	TB1F	—	—	ADE	TB1E
MFI0	—	—	T0AF	T0PF	—	—	T0AE	T0PE
MFI1	—	—	T1AF	T1PF	—	—	T1AE	T1PE
MFI2	—	DEF	T2AF	T2PF	—	DEE	T2AE	T2PE

Interrupt Register Contents

INTEG Register

Bit	7	6	5	4	3	2	1	0
Name	—	—	—	—	INT1S1	INT1S0	INT0S1	INT0S0
R/W	—	—	—	—	R/W	R/W	R/W	R/W
POR	—	—	—	—	0	0	0	0

- Bit 7~4 Unimplemented, read as “0”
- Bit 3~2 **INT1S1, INT1S0:** Defines INT1 interrupt active edge
 00: Disabled Interrupt
 01: Rising Edge Interrupt
 10: Falling Edge Interrupt
 11: Dual Edge Interrupt
- Bit 1~0 **INT0S1, INT0S0:** Defines INT0 interrupt active edge
 00: Disabled Interrupt
 01: Rising Edge Interrupt
 10: Falling Edge Interrupt
 11: Dual Edge Interrupt

INTC0 Register

Bit	7	6	5	4	3	2	1	0
Name	—	OVPF	OCP1F	OCP0F	OVPE	OCP1E	OCP0E	EMI
R/W	—	R/W	R/W	R/W	R/W	R/W	R/W	R/W
POR	—	0	0	0	0	0	0	0

- Bit 7 Unimplemented, read as “0”
- Bit 6 **OVPF:** OVP Interrupt Request Flag
 0: No request
 1: Interrupt request
- Bit 5 **OCP1F:** OCP1 interrupt request flag
 0: No request
 1: Interrupt request
- Bit 4 **OCP0F:** OCP0 interrupt request flag
 0: No request
 1: Interrupt request
- Bit 3 **OVPE:** OVP Interrupt Control
 0: Disable
 1: Enable
- Bit 2 **OCP1E:** OCP1 Interrupt Control
 0: Disable
 1: Enable
- Bit 1 **OCP0E:** OCP0 Interrupt Control
 0: Disable
 1: Enable
- Bit 0 **EMI:** Global Interrupt Control
 0: Disable
 1: Enable

INTC1 Register

Bit	7	6	5	4	3	2	1	0
Name	MF0F	INT1F	INT0F	UVPF	MF0E	INT1E	INT0E	UVPE
R/W	R/W	R/W	R/W	R/W	R/W	R/W	R/W	R/W
POR	0	0	0	0	0	0	0	0

- Bit 7 **MF0F:** Multi-function Interrupt 0 Request Flag
0: No request
1: Interrupt request
- Bit 6 **INT1F:** INT1 Interrupt Request Flag
0: No request
1: Interrupt request
- Bit 5 **INT0F:** INT0 Interrupt Request Flag
0: No request
1: Interrupt request
- Bit 4 **UVPF:** UVP Interrupt Request Flag
0: No request
1: Interrupt request
- Bit 3 **MF0E:** Multi-function Interrupt 0 Control
0: Disable
1: Enable
- Bit 2 **INT1E:** INT1 Interrupt Control
0: Disable
1: Enable
- Bit 1 **INT0E:** INT0 Interrupt Control
0: Disable
1: Enable
- Bit 0 **UVPE:** UVP Interrupt Control
0: Disable
1: Enable

INTC2 Register

Bit	7	6	5	4	3	2	1	0
Name	TB0F	LVF	MF2F	MF1F	TB0E	LVE	MF2E	MF1E
R/W	R/W	R/W	R/W	R/W	R/W	R/W	R/W	R/W
POR	0	0	0	0	0	0	0	0

- Bit 7 **TB0F:** Time base 0 Interrupt Request Flag
0: No request
1: Interrupt request
- Bit 6 **LVF:** LVD Interrupt Request Flag
0: No request
1: Interrupt request
- Bit 5 **MF2F:** Multi-function Interrupt 2 Request Flag
0: No request
1: Interrupt request
- Bit 4 **MF1F:** Multi-function Interrupt 1 Request Flag
0: No request
1: Interrupt request
- Bit 3 **TB0E:** Time Base 0 Interrupt Control
0: Disable
1: Enable
- Bit 2 **LVE:** LVD Interrupt Control
0: Disable
1: Enable

- Bit 1 **MF2E:** Multi-function Interrupt 2 Control
 0: Disable
 1: Enable
- Bit 0 **MF1E:** Multi-function Interrupt 1 Control
 0: Disable
 1: Enable

INTC3 Register

Bit	7	6	5	4	3	2	1	0
Name	—	—	ADF	TB1F	—	—	ADE	TB1E
R/W	—	—	R/W	R/W	—	—	R/W	R/W
POR	—	—	0	0	—	—	0	0

- Bit 7~6 Unimplemented, read as “0”
- Bit 5 **ADF:** A/D converter Interrupt Request Flag
 0: No request
 1: Interrupt request
- Bit 4 **TB1F:** Time base 1 Interrupt Request Flag
 0: No request
 1: Interrupt request
- Bit 3~2 Unimplemented, read as “0”
- Bit 1 **ADE:** A/D converter Interrupt Control
 0: Disable
 1: Enable
- Bit 0 **TB1E:** Time Base 1 Interrupt Control
 0: Disable
 1: Enable

MFIO Register

Bit	7	6	5	4	3	2	1	0
Name	—	—	TOAF	TOPF	—	—	TOAE	TOPE
R/W	—	—	R/W	R/W	—	—	R/W	R/W
POR	—	—	0	0	—	—	0	0

- Bit 7~6 Unimplemented, read as “0”
- Bit 5 **T0AF:** TM0 Comparator A match interrupt request flag
 0: No request
 1: Interrupt request
- Bit 4 **T0PF:** TM0 Comparator P match interrupt request flag
 0: No request
 1: Interrupt request
- Bit 3~2 Unimplemented, read as “0”
- Bit 1 **T0AE:** TM0 Comparator A match interrupt control
 0: Disable
 1: Enable
- Bit 0 **T0PE:** TM0 Comparator P match interrupt control
 0: Disable
 1: Enable

MFI1 Register

Bit	7	6	5	4	3	2	1	0
Name	—	—	T1AF	T1PF	—	—	T1AE	T1PE
R/W	—	—	R/W	R/W	—	—	R/W	R/W
POR	—	—	0	0	—	—	0	0

- Bit 7~6 Unimplemented, read as “0”
- Bit 5 **T1AF**: TM1 Comparator A match interrupt request flag
0: No request
1: Interrupt request
- Bit 4 **T1PF**: TM1 Comparator P match interrupt request flag
0: No request
1: Interrupt request
- Bit 3~2 Unimplemented, read as “0”
- Bit 1 **T1AE**: TM1 Comparator A match interrupt control
0: Disable
1: Enable
- Bit 0 **T1PE**: TM1 Comparator P match interrupt control
0: Disable
1: Enable

MFI2 Register

Bit	7	6	5	4	3	2	1	0
Name	—	DEF	T2AF	T2PF	—	DEE	T2AE	T2PE
R/W	—	R/W	R/W	R/W	—	R/W	R/W	R/W
POR	—	0	0	0	—	0	0	0

- Bit 7 Unimplemented, read as “0”
- Bit 6 **DEF**: Data EEPROM interrupt request flag
0: No request
1: Interrupt request
- Bit 5 **T2AE**: TM2 Comparator A match interrupt control
0: Disable
1: Enable
- Bit 4 **T2PE**: TM2 Comparator P match interrupt control
0: Disable
1: Enable
- Bit 3 Unimplemented, read as “0”
- Bit 2 **DEE**: Data EEPROM Interrupt Control
0: Disable
1: Enable
- Bit 1 **T2AE**: TM2 Comparator A match interrupt control
0: Disable
1: Enable
- Bit 0 **T2PE**: TM2 Comparator P match interrupt control
0: Disable
1: Enable

Interrupt Operation

When the conditions for an interrupt event occur, such as a TM Comparator P or Comparator A match or A/D conversion completion etc, the relevant interrupt request flag will be set. Whether the request flag actually generates a program jump to the relevant interrupt vector is determined by the condition of the interrupt enable bit. If the enable bit is set high then the program will jump to its relevant vector; if the enable bit is zero then although the interrupt request flag is set an actual interrupt will not be generated and the program will not jump to the relevant interrupt vector. The global interrupt enable bit, if cleared to zero, will disable all interrupts.

When an interrupt is generated, the Program Counter, which stores the address of the next instruction to be executed, will be transferred onto the stack. The Program Counter will then be loaded with a new address which will be the value of the corresponding interrupt vector. The microcontroller will then fetch its next instruction from this interrupt vector. The instruction at this vector will usually be a “JMP” which will jump to another section of program which is known as the interrupt service routine. Here is located the code to control the appropriate interrupt. The interrupt service routine must be terminated with a “RETI”, which retrieves the original Program Counter address from the stack and allows the microcontroller to continue with normal execution at the point where the interrupt occurred.

The various interrupt enable bits, together with their associated request flags, are shown in the accompanying diagrams with their order of priority. Some interrupt sources have their own individual vector while others share the same multi-function interrupt vector. Once an interrupt subroutine is serviced, all the other interrupts will be blocked, as the global interrupt enable bit, EMI bit will be cleared automatically. This will prevent any further interrupt nesting from occurring. However, if other interrupt requests occur during this interval, although the interrupt will not be immediately serviced, the request flag will still be recorded.

If an interrupt requires immediate servicing while the program is already in another interrupt service routine, the EMI bit should be set after entering the routine, to allow interrupt nesting. If the stack is full, the interrupt request will not be acknowledged, even if the related interrupt is enabled, until the Stack Pointer is decremented. If immediate service is desired, the stack must be prevented from becoming full. In case of simultaneous requests, the accompanying diagram shows the priority that is applied. All of the interrupt request flags when set will wake-up the device if it is in SLEEP or IDLE Mode, however to prevent a wake-up from occurring the corresponding flag should be set before the device is in SLEEP or IDLE Mode.

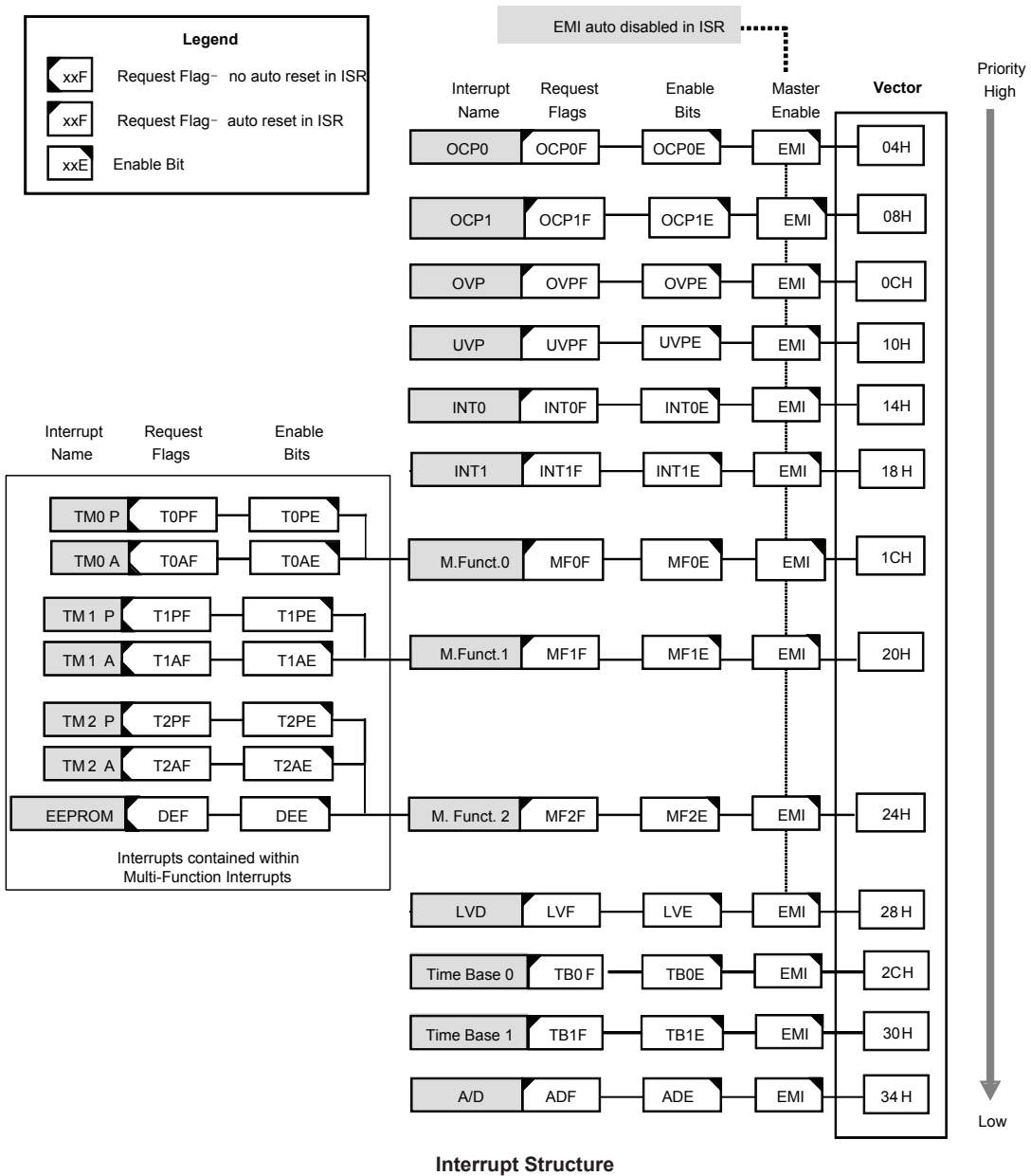
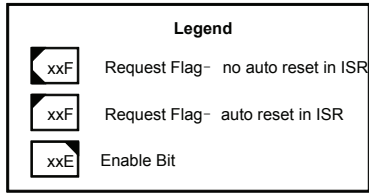

External Interrupt

The external interrupts are controlled by signal transitions on the pins INT0, INT1. An external interrupt request will take place when the external interrupt request flags, INT0F, INT1F, are set, which will occur when a transition, whose type is chosen by the edge select bits, appears on the external interrupt pins. To allow the program to branch to its respective interrupt vector address, the global interrupt enable bit, EMI, and respective external interrupt enable bit, INT0E, INT1E, must first be set. Additionally the correct interrupt edge type must be selected using the INTEG register to enable the external interrupt function and to choose the trigger edge type. As the external interrupt pins are pin-shared with I/O pins, they can only be configured as external interrupt pins if their external interrupt enable bit in the corresponding interrupt register has been set. The pin must also be setup as an input by setting the corresponding bit in the port control register. When the interrupt is enabled, the stack is not full and the correct transition type appears on the external interrupt pin, a subroutine call to the external interrupt vector, will take place. When the interrupt is serviced, the external interrupt request flags, INT0F, INT1F, will be automatically reset and the EMI bit will be automatically cleared to disable other interrupts. Note that any pull-high resistor selections on the external interrupt pins will remain valid even if the pin is used as an external interrupt input. The INTEG register is used to select the type of active edge that will trigger the external interrupt. A choice of either rising or falling or both edge types can be chosen to trigger an external interrupt. Note that the INTEG register can also be used to disable the external interrupt function.

UVP Interrupt

An UVP interrupt request will take place when the Under Voltage Protection Interrupt request flag, UVPF, is set, which occurs when the Under Voltage Protection function detects an under voltage condition. To allow the program to branch to its respective interrupt vector address, the global interrupt enable bit, EMI, and Under Voltage Protection Interrupt enable bit, must first be set. When the interrupt is enabled, the stack is not full and a low voltage condition occurs, a subroutine call to the UVP Interrupt vector, will take place. When the Under Voltage Protection Interrupt is serviced, the EMI bit will be automatically cleared to disable other interrupts and the interrupt request flag will be also automatically cleared.

OVP Interrupt

An OVP interrupt request will take place when the Over Voltage Protection Interrupt request flag, OVPF, is set, which occurs when the Over Voltage Protection function detects an over voltage condition. To allow the program to branch to its respective interrupt vector address, the global interrupt enable bit, EMI, and Over Voltage Protection Interrupt enable bit, must first be set. When the interrupt is enabled, the stack is not full and a low voltage condition occurs, a subroutine call to the OVP Interrupt vector, will take place. When the Over Voltage Protection Interrupt is serviced, the EMI bit will be automatically cleared to disable other interrupts and the interrupt request flag will be also automatically cleared.

OCP Interrupt

An OCP0, OCP1 interrupt request will take place when the Over Current Protection 0, 1 Interrupt request flag, OCP0F, OCP1F, is set, which occurs when the Over Current Protection 0, 1 function detects an over current condition. To allow the program to branch to its respective interrupt vector address, the global interrupt enable bit, EMI, and Over Current Protection 0, 1 Interrupt enable bit, must first be set. When the interrupt is enabled, the stack is not full and a low voltage condition occurs, a subroutine call to the OCP0, OCP1 Interrupt vector, will take place. When the Over Current Protection Interrupt is serviced, the EMI bit will be automatically cleared to disable other interrupts and the interrupt request flag will be also automatically cleared.

Multi-function Interrupt

Within this device there are up to three Multi-function interrupts. Unlike the other independent interrupts, these interrupts have no independent source, but rather are formed from other existing interrupt sources, namely the TM Interrupts and EEPROM Interrupt.

A Multi-function interrupt request will take place when any of the Multi-function interrupt request flags, MF0F~MF2F are set. The Multi-function interrupt flags will be set when any of their included functions generate an interrupt request flag. To allow the program to branch to its respective interrupt vector address, when the Multi-function interrupt is enabled and the stack is not full, and either one of the interrupts contained within each of Multi-function interrupt occurs, a subroutine call to one of the Multi-function interrupt vectors will take place. When the interrupt is serviced, the related Multi-Function request flag, will be automatically reset and the EMI bit will be automatically cleared to disable other interrupts.

However, it must be noted that, although the Multi-function Interrupt flags will be automatically reset when the interrupt is serviced, the request flags from the original source of the Multi-function interrupts, namely the TM Interrupts and EEPROM Interrupt will not be automatically reset and must be manually reset by the application program.

A/D Converter Interrupt

The A/D Converter Interrupt is controlled by the termination of an A/D conversion process. An A/D Converter Interrupt request will take place when the A/D Converter Interrupt request flag, ADF, is set, which occurs when the A/D conversion process finishes. To allow the program to branch to its respective interrupt vector address, the global interrupt enable bit, EMI, and A/D Interrupt enable bit, ADE, must first be set. When the interrupt is enabled, the stack is not full and the A/D conversion process has ended, a subroutine call to the A/D Converter Interrupt vector, will take place. When the interrupt is serviced, the A/D Converter Interrupt flag, ADF, will be automatically cleared. The EMI bit will also be automatically cleared to disable other interrupts.

Time Base Interrupts

The function of the Time Base Interrupts is to provide regular time signal in the form of an internal interrupt. They are controlled by the overflow signals from their respective timer functions. When these happens their respective interrupt request flags, TB0F or TB1F will be set. To allow the program to branch to their respective interrupt vector addresses, the global interrupt enable bit, EMI and Time Base enable bits, TB0E or TB1E, must first be set. When the interrupt is enabled, the stack is not full and the Time Base overflows, a subroutine call to their respective vector locations will take place. When the interrupt is serviced, the respective interrupt request flag, TB0F or TB1F, will be automatically reset and the EMI bit will be cleared to disable other interrupts.

The purpose of the Time Base Interrupt is to provide an interrupt signal at fixed time periods. Their clock sources originate from the internal clock source f_{TB} . This f_{TB} input clock passes through a divider, the division ratio of which is selected by programming the appropriate bits in the TBC register to obtain longer interrupt periods whose value ranges. The clock source that generates f_{TB} , which in turn controls the Time Base interrupt period, can originate from several different sources, as shown in the System Operating Mode section.

TBC Register

Bit	7	6	5	4	3	2	1	0
Name	TBON	TBCK	TB11	TB10	—	TB02	TB01	TB00
R/W	R/W	R/W	R/W	R/W	—	R/W	R/W	R/W
POR	0	0	1	1	—	1	1	1

- Bit 7 **TBON:** TB0 and TB1 Control bit
0: Disable
1: Enable
- Bit 6 **TBCK:** Select f_{TB} Clock
0: f_{TBC}
1: $f_{SYS}/4$
- Bit 5~4 **TB11~TB10:** Select Time Base 1 Time-out Period
00: $4096/f_{TB}$
01: $8192/f_{TB}$
10: $16384/f_{TB}$
11: $32768/f_{TB}$
- Bit 3 Unimplemented, read as “0”
- Bit 2~0 **TB02~TB00:** Select Time Base 0 Time-out Period
000: $256/f_{TB}$
001: $512/f_{TB}$
010: $1024/f_{TB}$
011: $2048/f_{TB}$
100: $4096/f_{TB}$
101: $8192/f_{TB}$
110: $16384/f_{TB}$
111: $32768/f_{TB}$

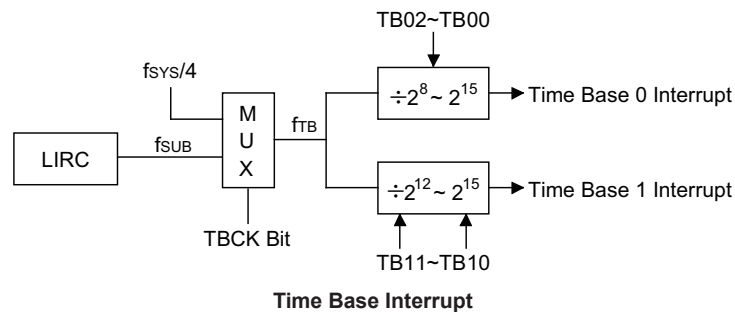

EEPROM Interrupt

The EEPROM interrupt is contained within the Multi-function Interrupt. An EEPROM Interrupt request will take place when the EEPROM Interrupt request flag, DEF, is set, which occurs when an EEPROM Write cycle ends. To allow the program to branch to its respective interrupt vector address, the global interrupt enable bit, EMI, and EEPROM Interrupt enable bit, DEE, and associated Multi-function interrupt enable bit, MF2E, must first be set. When the interrupt is enabled, the stack is not full and an EEPROM Write cycle ends, a subroutine call to the Multi-function Interrupt vector, will take place. When the EEPROM Interrupt is serviced, the EMI bit will be automatically cleared to disable other interrupts, however only the Multi-function interrupt request flag will be also automatically cleared. As the DEF flag will not be automatically cleared, it has to be cleared by the application program.

LVD Interrupt

An LVD Interrupt request will take place when the LVD Interrupt request flag, LVF, is set, which occurs when the Low Voltage Detector function detects a low power supply voltage. To allow the program to branch to its respective interrupt vector address, the global interrupt enable bit, EMI, and Low Voltage Interrupt enable bit, LVE, must first be set. When the interrupt is enabled, the stack is not full and a low voltage condition occurs, a subroutine call to the LVD Interrupt vector, will take place. When the Low Voltage Interrupt is serviced, the EMI bit will be automatically cleared to disable other interrupts, and the LVD interrupt request flag (LVF flag) will be also automatically cleared.

TM Interrupts

The Compact, Standard and Periodic type TMs all have two interrupts. All of the TM interrupts are contained within the Multi-function Interrupts. For the Standard Type TM there are two interrupt request flags TnPF and TnAF and two enable bits TnPE and TnAE. A TM interrupt request will take place when any of the TM request flags are set, a situation which occurs when a TM comparator P or comparator A match situation happens.

To allow the program to branch to its respective interrupt vector address, the global interrupt enable bit, EMI, and the respective TM Interrupt enable bit, and associated Multi-function interrupt enable bit, MFnF (MF0F, MF1F or MF2F), must first be set. When the interrupt is enabled, the stack is not full and a TM comparator match situation occurs, a subroutine call to the relevant TM Interrupt vector locations, will take place. When the TM interrupt is serviced, the EMI bit will be automatically cleared to disable other interrupts, however only the related MFnF flag (MF0F, MF1F or MF2F) will be automatically cleared. As the TM interrupt request flags will not be automatically cleared, they have to be cleared by the application program.

Interrupt Wake-up Function

Each of the interrupt functions has the capability of waking up the microcontroller when in the SLEEP or IDLE Mode. A wake-up is generated when an interrupt request flag changes from low to high and is independent of whether the interrupt is enabled or not. Therefore, even though the device is in the SLEEP or IDLE Mode and its system oscillator stopped, situations such as external edge transitions on the external interrupt pins, a low power supply voltage or comparator input change may cause their respective interrupt flag to be set high and consequently generate an interrupt. Care must therefore be taken if spurious wake-up situations are to be avoided. If an interrupt wake-up function is to be disabled then the corresponding interrupt request flag should be set high before the device enters the SLEEP or IDLE Mode. The interrupt enable bits have no effect on the interrupt wake-up function.

Programming Considerations

By disabling the relevant interrupt enable bits, a requested interrupt can be prevented from being serviced, however, once an interrupt request flag is set, it will remain in this condition in the interrupt register until the corresponding interrupt is serviced or until the request flag is cleared by the application program.

Where a certain interrupt is contained within a Multi-function interrupt, then when the interrupt service routine is executed, as only the Multi-function interrupt request flags, MF0F~MF2F, will be automatically cleared, the individual request flag for the function needs to be cleared by the application program.

It is recommended that programs do not use the “CALL” instruction within the interrupt service subroutine. Interrupts often occur in an unpredictable manner or need to be serviced immediately. If only one stack is left and the interrupt is not well controlled, the original control sequence will be damaged once a CALL subroutine is executed in the interrupt subroutine.

Every interrupt has the capability of waking up the microcontroller when it is in SLEEP or IDLE Mode, the wake up being generated when the interrupt request flag changes from low to high. If it is required to prevent a certain interrupt from waking up the microcontroller then its respective request flag should be first set high before enter SLEEP or IDLE Mode.

As only the Program Counter is pushed onto the stack, then when the interrupt is serviced, if the contents of the accumulator, status register or other registers are altered by the interrupt service program, their contents should be saved to the memory at the beginning of the interrupt service routine.

To return from an interrupt subroutine, either a RET or RETI instruction may be executed. The RETI instruction in addition to executing a return to the main program also automatically sets the EMI bit high to allow further interrupts. The RET instruction however only executes a return to the main program leaving the EMI bit in its present zero state and therefore disabling the execution of further interrupts.

Low Voltage Detector – LVD

The device has a Low Voltage Detector function, also known as LVD. This enables the device to monitor the power supply voltage, V_{DD} , and provides a warning signal should it fall below a certain level. This function may be especially useful in battery applications where the supply voltage will gradually reduce as the battery ages, as it allows an early warning battery low signal to be generated. The Low Voltage Detector also has the capability of generating an interrupt signal.

LVD Register

The Low Voltage Detector function is controlled using a single register with the name LVDC. Three bits in this register, VLVD2~VLVD0, are used to select one of eight fixed voltages below which a low voltage condition will be determined. A low voltage condition is indicated when the LVDO bit is set. If the LVDO bit is low, this indicates that the V_{DD} voltage is above the preset low voltage value. The LVDEN bit is used to control the overall on/off function of the low voltage detector. Setting the bit high will enable the low voltage detector. Clearing the bit to zero will switch off the internal low voltage detector circuits. As the low voltage detector will consume a certain amount of power, it may be desirable to switch off the circuit when not in use, an important consideration in power sensitive battery powered applications.

LVDC Register

Bit	7	6	5	4	3	2	1	0
Name	—	—	LVDO	LVDEN	—	VLVD2	VLVD1	VLVD0
R/W	—	—	R	R/W	—	R/W	R/W	R/W
POR	—	—	0	0	—	0	0	0

- Bit 7~6 Unimplemented, read as “0”
- Bit 5 **LVDO:** LVD Output Flag
 0: No Low Voltage Detect
 1: Low Voltage Detect
- Bit 4 **LVDEN:** Low Voltage Detector Control
 0: Disable
 1: Enable
- Bit 3 Unimplemented, read as “0”
- Bit 2~0 **VLVD2~VLVD0:** Select LVD Voltage
 000: 2.0V
 001: 2.2V
 010: 2.4V
 011: 2.7V
 100: 3.0V
 101: 3.3V
 110: 3.6V
 111: 4.0V

LVD Operation

The Low Voltage Detector function operates by comparing the power supply voltage, V_{DD} , with a pre-specified voltage level stored in the LVDC register. This has a range of between 2.2V and 4.0V. When the power supply voltage, V_{DD} , falls below this pre-determined value, the LVDO bit will be set high indicating a low power supply voltage condition. The Low Voltage Detector function is supplied by a reference voltage which will be automatically enabled. When the device is powered down the low voltage detector will remain active if the LVDEN bit is high. After enabling the Low Voltage Detector, a time delay t_{LVDS} should be allowed for the circuitry to stabilise before reading the LVDO bit. Note also that as the V_{DD} voltage may rise and fall rather slowly, at the voltage nears that of V_{LVD} , there may be multiple bit LVDO transitions.

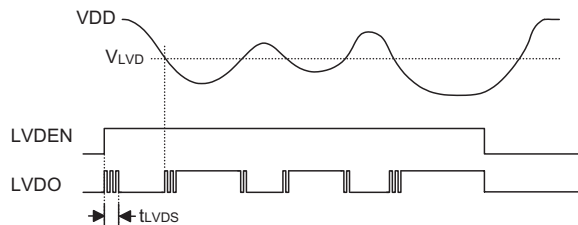

LVD Operation

The Low Voltage Detector also has its own interrupt which is contained within one of the Multi-function interrupts, providing an alternative means of low voltage detection, in addition to polling the LVDO bit. The interrupt will only be generated after a delay of t_{LVD} after the LVDO bit has been set high by a low voltage condition. When the device is powered down the Low Voltage Detector will remain active if the LVDEN bit is high. In this case, the LVF interrupt request flag will be set, causing an interrupt to be generated if V_{DD} falls below the preset LVD voltage. This will cause the device to wake-up from the SLEEP or IDLE Mode, however if the Low Voltage Detector wake up function is not required then the LVF flag should be first set high before the device enters the SLEEP or IDLE Mode.

Instruction Set

Introduction

Central to the successful operation of any microcontroller is its instruction set, which is a set of program instruction codes that directs the microcontroller to perform certain operations. In the case of Holtek microcontrollers, a comprehensive and flexible set of over 60 instructions is provided to enable programmers to implement their application with the minimum of programming overheads.

For easier understanding of the various instruction codes, they have been subdivided into several functional groupings.

Instruction Timing

Most instructions are implemented within one instruction cycle. The exceptions to this are branch, call, or table read instructions where two instruction cycles are required. One instruction cycle is equal to 4 system clock cycles, therefore in the case of a 4MHz system oscillator, most instructions would be implemented within 1 μ s and branch or call instructions would be implemented within 2 μ s. Although instructions which require one more cycle to implement are generally limited to the JMP, CALL, RET, RETI and table read instructions, it is important to realize that any other instructions which involve manipulation of the Program Counter Low register or PCL will also take one more cycle to implement. As instructions which change the contents of the PCL will imply a direct jump to that new address, one more cycle will be required. Examples of such instructions would be "CLR PCL" or "MOV PCL, A". For the case of skip instructions, it must be noted that if the result of the comparison involves a skip operation then this will also take one more cycle, if no skip is involved then only one cycle is required.

Moving and Transferring Data

The transfer of data within the microcontroller program is one of the most frequently used operations. Making use of three kinds of MOV instructions, data can be transferred from registers to the Accumulator and vice-versa as well as being able to move specific immediate data directly into the Accumulator. One of the most important data transfer applications is to receive data from the input ports and transfer data to the output ports.

Arithmetic Operations

The ability to perform certain arithmetic operations and data manipulation is a necessary feature of most microcontroller applications. Within the Holtek microcontroller instruction set are a range of add and subtract instruction mnemonics to enable the necessary arithmetic to be carried out. Care must be taken to ensure correct handling of carry and borrow data when results exceed 255 for addition and less than 0 for subtraction. The increment and decrement instructions INC, INCA, DEC and DECA provide a simple means of increasing or decreasing by a value of one of the values in the destination specified.

Logical and Rotate Operations

The standard logical operations such as AND, OR, XOR and CPL all have their own instruction within the Holtek microcontroller instruction set. As with the case of most instructions involving data manipulation, data must pass through the Accumulator which may involve additional programming steps. In all logical data operations, the zero flag may be set if the result of the operation is zero. Another form of logical data manipulation comes from the rotate instructions such as RR, RL, RRC and RLC which provide a simple means of rotating one bit right or left. Different rotate instructions exist depending on program requirements. Rotate instructions are useful for serial port programming applications where data can be rotated from an internal register into the Carry bit from where it can be examined and the necessary serial bit set high or low. Another application where rotate data operations are used is to implement multiplication and division calculations.

Branches and Control Transfer

Program branching takes the form of either jumps to specified locations using the JMP instruction or to a subroutine using the CALL instruction. They differ in the sense that in the case of a subroutine call, the program must return to the instruction immediately when the subroutine has been carried out. This is done by placing a return instruction RET in the subroutine which will cause the program to jump back to the address right after the CALL instruction. In the case of a JMP instruction, the program simply jumps to the desired location. There is no requirement to jump back to the original jumping off point as in the case of the CALL instruction. One special and extremely useful set of branch instructions are the conditional branches. Here a decision is first made regarding the condition of a certain data memory or individual bits. Depending upon the conditions, the program will continue with the next instruction or skip over it and jump to the following instruction. These instructions are the key to decision making and branching within the program perhaps determined by the condition of certain input switches or by the condition of internal data bits.

Bit Operations

The ability to provide single bit operations on Data Memory is an extremely flexible feature of all Holtek microcontrollers. This feature is especially useful for output port bit programming where individual bits or port pins can be directly set high or low using either the "SET [m].i" or "CLR [m].i" instructions respectively. The feature removes the need for programmers to first read the 8-bit output port, manipulate the input data to ensure that other bits are not changed and then output the port with the correct new data. This read-modify-write process is taken care of automatically when these bit operation instructions are used.

Table Read Operations

Data storage is normally implemented by using registers. However, when working with large amounts of fixed data, the volume involved often makes it inconvenient to store the fixed data in the Data Memory. To overcome this problem, Holtek microcontrollers allow an area of Program Memory to be setup as a table where data can be directly stored. A set of easy to use instructions provides the means by which this fixed data can be referenced and retrieved from the Program Memory.

Other Operations

In addition to the above functional instructions, a range of other instructions also exist such as the "HALT" instruction for Power-down operations and instructions to control the operation of the Watchdog Timer for reliable program operations under extreme electric or electromagnetic environments. For their relevant operations, refer to the functional related sections.

Instruction Set Summary

The following table depicts a summary of the instruction set categorised according to function and can be consulted as a basic instruction reference using the following listed conventions.

Table conventions:

x: Bits immediate data

m: Data Memory address

A: Accumulator

i: 0~7 number of bits

addr: Program memory address

Mnemonic	Description	Cycles	Flag Affected
Arithmetic			
ADD A,[m]	Add Data Memory to ACC	1	Z, C, AC, OV
ADDM A,[m]	Add ACC to Data Memory	1 ^{Note}	Z, C, AC, OV
ADD A,x	Add immediate data to ACC	1	Z, C, AC, OV
ADC A,[m]	Add Data Memory to ACC with Carry	1	Z, C, AC, OV
ADCM A,[m]	Add ACC to Data memory with Carry	1 ^{Note}	Z, C, AC, OV
SUB A,x	Subtract immediate data from the ACC	1	Z, C, AC, OV
SUB A,[m]	Subtract Data Memory from ACC	1	Z, C, AC, OV
SUBM A,[m]	Subtract Data Memory from ACC with result in Data Memory	1 ^{Note}	Z, C, AC, OV
SBC A,[m]	Subtract Data Memory from ACC with Carry	1	Z, C, AC, OV
SBCM A,[m]	Subtract Data Memory from ACC with Carry, result in Data Memory	1 ^{Note}	Z, C, AC, OV
DAA [m]	Decimal adjust ACC for Addition with result in Data Memory	1 ^{Note}	C
Logic Operation			
AND A,[m]	Logical AND Data Memory to ACC	1	Z
OR A,[m]	Logical OR Data Memory to ACC	1	Z
XOR A,[m]	Logical XOR Data Memory to ACC	1	Z
ANDM A,[m]	Logical AND ACC to Data Memory	1 ^{Note}	Z
ORM A,[m]	Logical OR ACC to Data Memory	1 ^{Note}	Z
XORM A,[m]	Logical XOR ACC to Data Memory	1 ^{Note}	Z
AND A,x	Logical AND immediate Data to ACC	1	Z
OR A,x	Logical OR immediate Data to ACC	1	Z
XOR A,x	Logical XOR immediate Data to ACC	1	Z
CPL [m]	Complement Data Memory	1 ^{Note}	Z
CPLA [m]	Complement Data Memory with result in ACC	1	Z
Increment & Decrement			
INCA [m]	Increment Data Memory with result in ACC	1	Z
INC [m]	Increment Data Memory	1 ^{Note}	Z
DECA [m]	Decrement Data Memory with result in ACC	1	Z
DEC [m]	Decrement Data Memory	1 ^{Note}	Z
Rotate			
RRA [m]	Rotate Data Memory right with result in ACC	1	None
RR [m]	Rotate Data Memory right	1 ^{Note}	None
RRCA [m]	Rotate Data Memory right through Carry with result in ACC	1	C
RRC [m]	Rotate Data Memory right through Carry	1 ^{Note}	C
RLA [m]	Rotate Data Memory left with result in ACC	1	None
RL [m]	Rotate Data Memory left	1 ^{Note}	None
RLCA [m]	Rotate Data Memory left through Carry with result in ACC	1	C
RLC [m]	Rotate Data Memory left through Carry	1 ^{Note}	C
Data Move			
MOV A,[m]	Move Data Memory to ACC	1	None
MOV [m],A	Move ACC to Data Memory	1 ^{Note}	None
MOV A,x	Move immediate data to ACC	1	None
Bit Operation			
CLR [m].i	Clear bit of Data Memory	1 ^{Note}	None
SET [m].i	Set bit of Data Memory	1 ^{Note}	None

Mnemonic	Description	Cycles	Flag Affected
Branch			
JMP addr	Jump unconditionally	2	None
SZ [m]	Skip if Data Memory is zero	1 ^{Note}	None
SZA [m]	Skip if Data Memory is zero with data movement to ACC	1 ^{note}	None
SZ [m].i	Skip if bit i of Data Memory is zero	1 ^{Note}	None
SNZ [m].i	Skip if bit i of Data Memory is not zero	1 ^{Note}	None
SIZ [m]	Skip if increment Data Memory is zero	1 ^{Note}	None
SDZ [m]	Skip if decrement Data Memory is zero	1 ^{Note}	None
SIZA [m]	Skip if increment Data Memory is zero with result in ACC	1 ^{Note}	None
SDZA [m]	Skip if decrement Data Memory is zero with result in ACC	1 ^{Note}	None
CALL addr	Subroutine call	2	None
RET	Return from subroutine	2	None
RET A,x	Return from subroutine and load immediate data to ACC	2	None
RETI	Return from interrupt	2	None
Table Read			
TABRD [m]	Read table (specific page) to TBLH and Data Memory	2 ^{Note}	None
TABRDC [m]	Read table (current page) to TBLH and Data Memory	2 ^{Note}	None
TABRDL [m]	Read table (last page) to TBLH and Data Memory	2 ^{Note}	None
Miscellaneous			
NOP	No operation	1	None
CLR [m]	Clear Data Memory	1 ^{Note}	None
SET [m]	Set Data Memory	1 ^{Note}	None
CLR WDT	Clear Watchdog Timer	1	TO, PDF
CLR WDT1	Pre-clear Watchdog Timer	1	TO, PDF
CLR WDT2	Pre-clear Watchdog Timer	1	TO, PDF
SWAP [m]	Swap nibbles of Data Memory	1 ^{Note}	None
SWAPA [m]	Swap nibbles of Data Memory with result in ACC	1	None
HALT	Enter power down mode	1	TO, PDF

Note: 1. For skip instructions, if the result of the comparison involves a skip then two cycles are required, if no skip takes place only one cycle is required.

2. Any instruction which changes the contents of the PCL will also require 2 cycles for execution.

3. For the "CLR WDT1" and "CLR WDT2" instructions the TO and PDF flags may be affected by the execution status. The TO and PDF flags are cleared after both "CLR WDT1" and "CLR WDT2" instructions are consecutively executed. Otherwise the TO and PDF flags remain unchanged.

Instruction Definition

ADC A,[m]	Add Data Memory to ACC with Carry
Description	The contents of the specified Data Memory, Accumulator and the carry flag are added. The result is stored in the Accumulator.
Operation	$ACC \leftarrow ACC + [m] + C$
Affected flag(s)	OV, Z, AC, C
ADCM A,[m]	Add ACC to Data Memory with Carry
Description	The contents of the specified Data Memory, Accumulator and the carry flag are added. The result is stored in the specified Data Memory.
Operation	$[m] \leftarrow ACC + [m] + C$
Affected flag(s)	OV, Z, AC, C
ADD A,[m]	Add Data Memory to ACC
Description	The contents of the specified Data Memory and the Accumulator are added. The result is stored in the Accumulator.
Operation	$ACC \leftarrow ACC + [m]$
Affected flag(s)	OV, Z, AC, C
ADD A,x	Add immediate data to ACC
Description	The contents of the Accumulator and the specified immediate data are added. The result is stored in the Accumulator.
Operation	$ACC \leftarrow ACC + x$
Affected flag(s)	OV, Z, AC, C
ADDM A,[m]	Add ACC to Data Memory
Description	The contents of the specified Data Memory and the Accumulator are added. The result is stored in the specified Data Memory.
Operation	$[m] \leftarrow ACC + [m]$
Affected flag(s)	OV, Z, AC, C
AND A,[m]	Logical AND Data Memory to ACC
Description	Data in the Accumulator and the specified Data Memory perform a bitwise logical AND operation. The result is stored in the Accumulator.
Operation	$ACC \leftarrow ACC \text{ "AND" } [m]$
Affected flag(s)	Z
AND A,x	Logical AND immediate data to ACC
Description	Data in the Accumulator and the specified immediate data perform a bit wise logical AND operation. The result is stored in the Accumulator.
Operation	$ACC \leftarrow ACC \text{ "AND" } x$
Affected flag(s)	Z
ANDM A,[m]	Logical AND ACC to Data Memory
Description	Data in the specified Data Memory and the Accumulator perform a bitwise logical AND operation. The result is stored in the Data Memory.
Operation	$[m] \leftarrow ACC \text{ "AND" } [m]$
Affected flag(s)	Z

CALL addr	Subroutine call
Description	Unconditionally calls a subroutine at the specified address. The Program Counter then increments by 1 to obtain the address of the next instruction which is then pushed onto the stack. The specified address is then loaded and the program continues execution from this new address. As this instruction requires an additional operation, it is a two cycle instruction.
Operation	Stack \leftarrow Program Counter + 1 Program Counter \leftarrow addr
Affected flag(s)	None
CLR [m]	Clear Data Memory
Description	Each bit of the specified Data Memory is cleared to 0.
Operation	[m] \leftarrow 00H
Affected flag(s)	None
CLR [m].i	Clear bit of Data Memory
Description	Bit i of the specified Data Memory is cleared to 0.
Operation	[m].i \leftarrow 0
Affected flag(s)	None
CLR WDT	Clear Watchdog Timer
Description	The TO, PDF flags and the WDT are all cleared.
Operation	WDT cleared TO \leftarrow 0 PDF \leftarrow 0
Affected flag(s)	TO, PDF
CLR WDT1	Pre-clear Watchdog Timer
Description	The TO, PDF flags and the WDT are all cleared. Note that this instruction works in conjunction with CLR WDT2 and must be executed alternately with CLR WDT2 to have effect. Repetitively executing this instruction without alternately executing CLR WDT2 will have no effect.
Operation	WDT cleared TO \leftarrow 0 PDF \leftarrow 0
Affected flag(s)	TO, PDF
CLR WDT2	Pre-clear Watchdog Timer
Description	The TO, PDF flags and the WDT are all cleared. Note that this instruction works in conjunction with CLR WDT1 and must be executed alternately with CLR WDT1 to have effect. Repetitively executing this instruction without alternately executing CLR WDT1 will have no effect.
Operation	WDT cleared TO \leftarrow 0 PDF \leftarrow 0
Affected flag(s)	TO, PDF
CPL [m]	Complement Data Memory
Description	Each bit of the specified Data Memory is logically complemented (1's complement). Bits which previously contained a 1 are changed to 0 and vice versa.
Operation	[m] \leftarrow $\overline{[m]}$
Affected flag(s)	Z

CPLA [m]	Complement Data Memory with result in ACC
Description	Each bit of the specified Data Memory is logically complemented (1's complement). Bits which previously contained a 1 are changed to 0 and vice versa. The complemented result is stored in the Accumulator and the contents of the Data Memory remain unchanged.
Operation	$ACC \leftarrow \overline{[m]}$
Affected flag(s)	Z
DAA [m]	Decimal-Adjust ACC for addition with result in Data Memory
Description	Convert the contents of the Accumulator value to a BCD (Binary Coded Decimal) value resulting from the previous addition of two BCD variables. If the low nibble is greater than 9 or if AC flag is set, then a value of 6 will be added to the low nibble. Otherwise the low nibble remains unchanged. If the high nibble is greater than 9 or if the C flag is set, then a value of 6 will be added to the high nibble. Essentially, the decimal conversion is performed by adding 00H, 06H, 60H or 66H depending on the Accumulator and flag conditions. Only the C flag may be affected by this instruction which indicates that if the original BCD sum is greater than 100, it allows multiple precision decimal addition.
Operation	$[m] \leftarrow ACC + 00H$ or $[m] \leftarrow ACC + 06H$ or $[m] \leftarrow ACC + 60H$ or $[m] \leftarrow ACC + 66H$
Affected flag(s)	C
DEC [m]	Decrement Data Memory
Description	Data in the specified Data Memory is decremented by 1.
Operation	$[m] \leftarrow [m] - 1$
Affected flag(s)	Z
DECA [m]	Decrement Data Memory with result in ACC
Description	Data in the specified Data Memory is decremented by 1. The result is stored in the Accumulator. The contents of the Data Memory remain unchanged.
Operation	$ACC \leftarrow [m] - 1$
Affected flag(s)	Z
HALT	Enter power down mode
Description	This instruction stops the program execution and turns off the system clock. The contents of the Data Memory and registers are retained. The WDT and prescaler are cleared. The power down flag PDF is set and the WDT time-out flag TO is cleared.
Operation	TO \leftarrow 0 PDF \leftarrow 1
Affected flag(s)	TO, PDF
INC [m]	Increment Data Memory
Description	Data in the specified Data Memory is incremented by 1.
Operation	$[m] \leftarrow [m] + 1$
Affected flag(s)	Z
INCA [m]	Increment Data Memory with result in ACC
Description	Data in the specified Data Memory is incremented by 1. The result is stored in the Accumulator. The contents of the Data Memory remain unchanged.
Operation	$ACC \leftarrow [m] + 1$
Affected flag(s)	Z

JMP addr	Jump unconditionally
Description	The contents of the Program Counter are replaced with the specified address. Program execution then continues from this new address. As this requires the insertion of a dummy instruction while the new address is loaded, it is a two cycle instruction.
Operation	Program Counter \leftarrow addr
Affected flag(s)	None
MOV A,[m]	Move Data Memory to ACC
Description	The contents of the specified Data Memory are copied to the Accumulator.
Operation	ACC \leftarrow [m]
Affected flag(s)	None
MOV A,x	Move immediate data to ACC
Description	The immediate data specified is loaded into the Accumulator.
Operation	ACC \leftarrow x
Affected flag(s)	None
MOV [m],A	Move ACC to Data Memory
Description	The contents of the Accumulator are copied to the specified Data Memory.
Operation	[m] \leftarrow ACC
Affected flag(s)	None
NOP	No operation
Description	No operation is performed. Execution continues with the next instruction.
Operation	No operation
Affected flag(s)	None
OR A,[m]	Logical OR Data Memory to ACC
Description	Data in the Accumulator and the specified Data Memory perform a bitwise logical OR operation. The result is stored in the Accumulator.
Operation	ACC \leftarrow ACC "OR" [m]
Affected flag(s)	Z
OR A,x	Logical OR immediate data to ACC
Description	Data in the Accumulator and the specified immediate data perform a bitwise logical OR operation. The result is stored in the Accumulator.
Operation	ACC \leftarrow ACC "OR" x
Affected flag(s)	Z
ORM A,[m]	Logical OR ACC to Data Memory
Description	Data in the specified Data Memory and the Accumulator perform a bitwise logical OR operation. The result is stored in the Data Memory.
Operation	[m] \leftarrow ACC "OR" [m]
Affected flag(s)	Z
RET	Return from subroutine
Description	The Program Counter is restored from the stack. Program execution continues at the restored address.
Operation	Program Counter \leftarrow Stack
Affected flag(s)	None

RET A,x	Return from subroutine and load immediate data to ACC
Description	The Program Counter is restored from the stack and the Accumulator loaded with the specified immediate data. Program execution continues at the restored address.
Operation	Program Counter ← Stack ACC ← x
Affected flag(s)	None
RETI	Return from interrupt
Description	The Program Counter is restored from the stack and the interrupts are re-enabled by setting the EMI bit. EMI is the master interrupt global enable bit. If an interrupt was pending when the RETI instruction is executed, the pending Interrupt routine will be processed before returning to the main program.
Operation	Program Counter ← Stack EMI ← 1
Affected flag(s)	None
RL [m]	Rotate Data Memory left
Description	The contents of the specified Data Memory are rotated left by 1 bit with bit 7 rotated into bit 0.
Operation	[m].(i+1) ← [m].i; (i=0~6) [m].0 ← [m].7
Affected flag(s)	None
RLA [m]	Rotate Data Memory left with result in ACC
Description	The contents of the specified Data Memory are rotated left by 1 bit with bit 7 rotated into bit 0. The rotated result is stored in the Accumulator and the contents of the Data Memory remain unchanged.
Operation	ACC.(i+1) ← [m].i; (i=0~6) ACC.0 ← [m].7
Affected flag(s)	None
RLC [m]	Rotate Data Memory left through Carry
Description	The contents of the specified Data Memory and the carry flag are rotated left by 1 bit. Bit 7 replaces the Carry bit and the original carry flag is rotated into bit 0.
Operation	[m].(i+1) ← [m].i; (i=0~6) [m].0 ← C C ← [m].7
Affected flag(s)	C
RLCA [m]	Rotate Data Memory left through Carry with result in ACC
Description	Data in the specified Data Memory and the carry flag are rotated left by 1 bit. Bit 7 replaces the Carry bit and the original carry flag is rotated into the bit 0. The rotated result is stored in the Accumulator and the contents of the Data Memory remain unchanged.
Operation	ACC.(i+1) ← [m].i; (i=0~6) ACC.0 ← C C ← [m].7
Affected flag(s)	C
RR [m]	Rotate Data Memory right
Description	The contents of the specified Data Memory are rotated right by 1 bit with bit 0 rotated into bit 7.
Operation	[m].i ← [m].(i+1); (i=0~6) [m].7 ← [m].0
Affected flag(s)	None

RRA [m]	Rotate Data Memory right with result in ACC
Description	Data in the specified Data Memory and the carry flag are rotated right by 1 bit with bit 0 rotated into bit 7. The rotated result is stored in the Accumulator and the contents of the Data Memory remain unchanged.
Operation	$ACC.i \leftarrow [m].(i+1); (i=0\sim6)$ $ACC.7 \leftarrow [m].0$
Affected flag(s)	None
RRC [m]	Rotate Data Memory right through Carry
Description	The contents of the specified Data Memory and the carry flag are rotated right by 1 bit. Bit 0 replaces the Carry bit and the original carry flag is rotated into bit 7.
Operation	$[m].i \leftarrow [m].(i+1); (i=0\sim6)$ $[m].7 \leftarrow C$ $C \leftarrow [m].0$
Affected flag(s)	C
RRCA [m]	Rotate Data Memory right through Carry with result in ACC
Description	Data in the specified Data Memory and the carry flag are rotated right by 1 bit. Bit 0 replaces the Carry bit and the original carry flag is rotated into bit 7. The rotated result is stored in the Accumulator and the contents of the Data Memory remain unchanged.
Operation	$ACC.i \leftarrow [m].(i+1); (i=0\sim6)$ $ACC.7 \leftarrow C$ $C \leftarrow [m].0$
Affected flag(s)	C
SBC A,[m]	Subtract Data Memory from ACC with Carry
Description	The contents of the specified Data Memory and the complement of the carry flag are subtracted from the Accumulator. The result is stored in the Accumulator. Note that if the result of subtraction is negative, the C flag will be cleared to 0, otherwise if the result is positive or zero, the C flag will be set to 1.
Operation	$ACC \leftarrow ACC - [m] - C$
Affected flag(s)	OV, Z, AC, C
SBCM A,[m]	Subtract Data Memory from ACC with Carry and result in Data Memory
Description	The contents of the specified Data Memory and the complement of the carry flag are subtracted from the Accumulator. The result is stored in the Data Memory. Note that if the result of subtraction is negative, the C flag will be cleared to 0, otherwise if the result is positive or zero, the C flag will be set to 1.
Operation	$[m] \leftarrow ACC - [m] - C$
Affected flag(s)	OV, Z, AC, C
SDZ [m]	Skip if decrement Data Memory is 0
Description	The contents of the specified Data Memory are first decremented by 1. If the result is 0 the following instruction is skipped. As this requires the insertion of a dummy instruction while the next instruction is fetched, it is a two cycle instruction. If the result is not 0 the program proceeds with the following instruction.
Operation	$[m] \leftarrow [m] - 1$ Skip if $[m]=0$
Affected flag(s)	None

SDZA [m]	Skip if decrement Data Memory is zero with result in ACC
Description	The contents of the specified Data Memory are first decremented by 1. If the result is 0, the following instruction is skipped. The result is stored in the Accumulator but the specified Data Memory contents remain unchanged. As this requires the insertion of a dummy instruction while the next instruction is fetched, it is a two cycle instruction. If the result is not 0, the program proceeds with the following instruction.
Operation	$ACC \leftarrow [m] - 1$ Skip if ACC=0
Affected flag(s)	None
SET [m]	Set Data Memory
Description	Each bit of the specified Data Memory is set to 1.
Operation	$[m] \leftarrow FFH$
Affected flag(s)	None
SET [m].i	Set bit of Data Memory
Description	Bit i of the specified Data Memory is set to 1.
Operation	$[m].i \leftarrow 1$
Affected flag(s)	None
SIZ [m]	Skip if increment Data Memory is 0
Description	The contents of the specified Data Memory are first incremented by 1. If the result is 0, the following instruction is skipped. As this requires the insertion of a dummy instruction while the next instruction is fetched, it is a two cycle instruction. If the result is not 0 the program proceeds with the following instruction.
Operation	$[m] \leftarrow [m] + 1$ Skip if [m]=0
Affected flag(s)	None
SIZA [m]	Skip if increment Data Memory is zero with result in ACC
Description	The contents of the specified Data Memory are first incremented by 1. If the result is 0, the following instruction is skipped. The result is stored in the Accumulator but the specified Data Memory contents remain unchanged. As this requires the insertion of a dummy instruction while the next instruction is fetched, it is a two cycle instruction. If the result is not 0 the program proceeds with the following instruction.
Operation	$ACC \leftarrow [m] + 1$ Skip if ACC=0
Affected flag(s)	None
SNZ [m].i	Skip if bit i of Data Memory is not 0
Description	If bit i of the specified Data Memory is not 0, the following instruction is skipped. As this requires the insertion of a dummy instruction while the next instruction is fetched, it is a two cycle instruction. If the result is 0 the program proceeds with the following instruction.
Operation	Skip if $[m].i \neq 0$
Affected flag(s)	None
SUB A,[m]	Subtract Data Memory from ACC
Description	The specified Data Memory is subtracted from the contents of the Accumulator. The result is stored in the Accumulator. Note that if the result of subtraction is negative, the C flag will be cleared to 0, otherwise if the result is positive or zero, the C flag will be set to 1.
Operation	$ACC \leftarrow ACC - [m]$
Affected flag(s)	OV, Z, AC, C

SUBM A,[m]	Subtract Data Memory from ACC with result in Data Memory
Description	The specified Data Memory is subtracted from the contents of the Accumulator. The result is stored in the Data Memory. Note that if the result of subtraction is negative, the C flag will be cleared to 0, otherwise if the result is positive or zero, the C flag will be set to 1.
Operation	$[m] \leftarrow ACC - [m]$
Affected flag(s)	OV, Z, AC, C
SUB A,x	Subtract immediate data from ACC
Description	The immediate data specified by the code is subtracted from the contents of the Accumulator. The result is stored in the Accumulator. Note that if the result of subtraction is negative, the C flag will be cleared to 0, otherwise if the result is positive or zero, the C flag will be set to 1.
Operation	$ACC \leftarrow ACC - x$
Affected flag(s)	OV, Z, AC, C
SWAP [m]	Swap nibbles of Data Memory
Description	The low-order and high-order nibbles of the specified Data Memory are interchanged.
Operation	$[m].3 \sim [m].0 \leftrightarrow [m].7 \sim [m].4$
Affected flag(s)	None
SWAPA [m]	Swap nibbles of Data Memory with result in ACC
Description	The low-order and high-order nibbles of the specified Data Memory are interchanged. The result is stored in the Accumulator. The contents of the Data Memory remain unchanged.
Operation	$ACC.3 \sim ACC.0 \leftarrow [m].7 \sim [m].4$ $ACC.7 \sim ACC.4 \leftarrow [m].3 \sim [m].0$
Affected flag(s)	None
SZ [m]	Skip if Data Memory is 0
Description	If the contents of the specified Data Memory is 0, the following instruction is skipped. As this requires the insertion of a dummy instruction while the next instruction is fetched, it is a two cycle instruction. If the result is not 0 the program proceeds with the following instruction.
Operation	Skip if $[m]=0$
Affected flag(s)	None
SZA [m]	Skip if Data Memory is 0 with data movement to ACC
Description	The contents of the specified Data Memory are copied to the Accumulator. If the value is zero, the following instruction is skipped. As this requires the insertion of a dummy instruction while the next instruction is fetched, it is a two cycle instruction. If the result is not 0 the program proceeds with the following instruction.
Operation	$ACC \leftarrow [m]$ Skip if $[m]=0$
Affected flag(s)	None
SZ [m].i	Skip if bit i of Data Memory is 0
Description	If bit i of the specified Data Memory is 0, the following instruction is skipped. As this requires the insertion of a dummy instruction while the next instruction is fetched, it is a two cycle instruction. If the result is not 0, the program proceeds with the following instruction.
Operation	Skip if $[m].i=0$
Affected flag(s)	None

TABRD [m]	Read table (specific page) to TBLH and Data Memory
Description	The low byte of the program code addressed by the table pointer pair (TBHP and TBLP) is moved to the specified Data Memory and the high byte moved to TBLH..
Operation	[m] ← program code (low byte) TBLH ← program code (high byte)
Affected flag(s)	None
TABRDC [m]	Read table (current page) to TBLH and Data Memory
Description	The low byte of the program code (current page) addressed by the table pointer (TBLP) is moved to the specified Data Memory and the high byte moved to TBLH.
Operation	[m] ← program code (low byte) TBLH ← program code (high byte)
Affected flag(s)	None
TABRDL [m]	Read table (last page) to TBLH and Data Memory
Description	The low byte of the program code (last page) addressed by the table pointer (TBLP) is moved to the specified Data Memory and the high byte moved to TBLH.
Operation	[m] ← program code (low byte) TBLH ← program code (high byte)
Affected flag(s)	None
XOR A,[m]	Logical XOR Data Memory to ACC
Description	Data in the Accumulator and the specified Data Memory perform a bitwise logical XOR operation. The result is stored in the Accumulator.
Operation	ACC ← ACC "XOR" [m]
Affected flag(s)	Z
XORM A,[m]	Logical XOR ACC to Data Memory
Description	Data in the specified Data Memory and the Accumulator perform a bitwise logical XOR operation. The result is stored in the Data Memory.
Operation	[m] ← ACC "XOR" [m]
Affected flag(s)	Z
XOR A,x	Logical XOR immediate data to ACC
Description	Data in the Accumulator and the specified immediate data perform a bitwise logical XOR operation. The result is stored in the Accumulator.
Operation	ACC ← ACC "XOR" x
Affected flag(s)	Z

Package Information

Note that the package information provided here is for consultation purposes only. As this information may be updated at regular intervals users are reminded to consult the [Holtek website](#) for the latest version of the [Package/Carton Information](#).

Additional supplementary information with regard to packaging is listed below. Click on the relevant section to be transferred to the relevant website page.

- Package Information (include Outline Dimensions, Product Tape and Reel Specifications)
- The Operation Instruction of Packing Materials
- Carton information

16-pin NSOP (150mil) Outline Dimensions

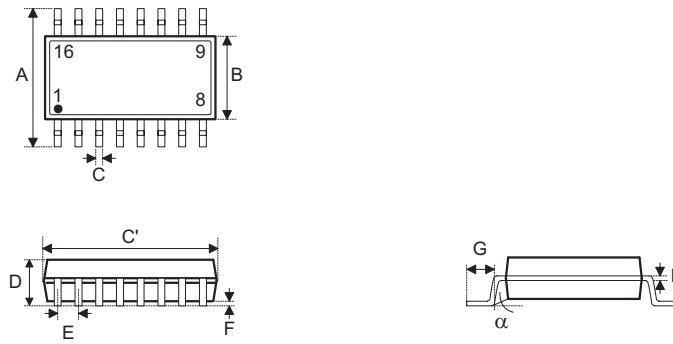

Symbol	Dimensions in inch		
	Min.	Nom.	Max.
A	—	0.236 BSC	—
B	—	0.154 BSC	—
C	0.012	—	0.020
C'	—	0.390 BSC	—
D	—	—	0.069
E	—	0.050 BSC	—
F	0.004	—	0.010
G	0.016	—	0.050
H	0.004	—	0.010
α	0°	—	8°

Symbol	Dimensions in mm		
	Min.	Nom.	Max.
A	—	6 BSC	—
B	—	3.9 BSC	—
C	0.31	—	0.51
C'	—	9.9 BSC	—
D	—	—	1.75
E	—	1.27 BSC	—
F	0.10	—	0.25
G	0.40	—	1.27
H	0.10	—	0.25
α	0°	—	8°

20-pin SSOP (150mil) Outline Dimensions

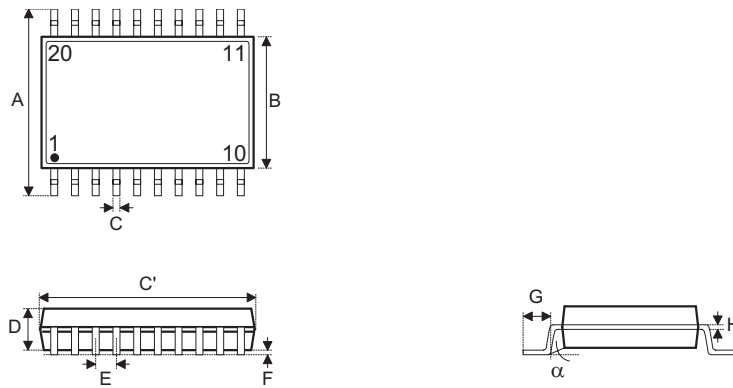

Symbol	Dimensions in inch		
	Min.	Nom.	Max.
A	—	0.236 BSC	—
B	—	0.155 BSC	—
C	0.008	—	0.012
C'	—	0.341 BSC	—
D	—	—	0.069
E	—	0.025 BSC	—
F	0.004	—	0.0098
G	0.016	—	0.05
H	0.004	—	0.01
α	0°	—	8°

Symbol	Dimensions in mm		
	Min.	Nom.	Max.
A	—	6 BSC	—
B	—	3.9 BSC	—
C	0.20	—	0.30
C'	—	8.66 BSC	—
D	—	—	1.75
E	—	0.635 BSC	—
F	0.10	—	0.25
G	0.41	—	1.27
H	0.10	—	0.25
α	0°	—	8°

Copyright© 2017 by HOLTEK SEMICONDUCTOR INC.

The information appearing in this Data Sheet is believed to be accurate at the time of publication. However, Holtek assumes no responsibility arising from the use of the specifications described. The applications mentioned herein are used solely for the purpose of illustration and Holtek makes no warranty or representation that such applications will be suitable without further modification, nor recommends the use of its products for application that may present a risk to human life due to malfunction or otherwise. Holtek's products are not authorized for use as critical components in life support devices or systems. Holtek reserves the right to alter its products without prior notification. For the most up-to-date information, please visit our web site at <http://www.holtek.com/en/>.