

APPROVAL

| PART NO. | DESCRIPTION | REMARKS |
|-------------------|--|---------------------------------|
| HT5702UL-T | LCD MODULE (320 × RGB × 240) | * This is ROHS compliant |

| | |
|--------------------------|--|
| CUSTOMER APPLICATION P/N | |
| APPROVED BY | |
| DATE | |

PLEASE KINDLY FIND AND APPROVE THE SPECIFICATIONS INSERTED
HEREIN AND RETURN ONE COPY HERE OF WITH YOUR SIGNATURE OF APPROVAL.

| | | |
|-------------|------------|--------------|
| PERPARED BY | CHECKED BY | CONFIRMED BY |
| | | |



HYES Optoelectronics, Inc.

2000 Wyatt Drive Suite 6
Santa Clara, CA 95054 USA

CONTENTS:

| No. | Item |
|-----|--|
| 1 | BASIC SPECIFICATION 1.1 Mechanical Specification 1.2 Display Specification 1.3 Outline Dimension 1.4 Block Diagram 1.5 Interface Pin |
| 2 | ELECTRICAL CHARACTERISTICS 2.1 Absolute Maximum Ratings 2.2 DC Characteristics 2.3 AC Characteristics 2.4 Interface Timing Chart |
| 3 | OPTICAL CHARACTERISTICS 3.1 Condition 3.2 Definition of Optical Characteristics |
| 4 | RELIABILITY |
| 5 | PRODUCT HANDLING AND APPLICATION |
| 6 | DATECODE |
| 7 | PACKING & LOTNO |
| 8 | INSPECTION STANDARD |

Date : Apr. 12, 2007

TECHNICAL SPECIFICATION

HYES

LCM

HT5702UL-T

Page 2 of 21

1. BASIC SPECIFICATION

1.1 Mechanical specifications

| Items | Nominal Dimension | Unit |
|-------------------------|----------------------|------|
| Dot Matrix | 320*RGB*240 | dots |
| Module Size (W x H x T) | 154.6 x 114.8 x 9.85 | mm. |
| Viewing Area (W x H) | 116.2 x 87.4 | mm. |
| Active Area (W x H) | 115.2 x 86.4 | mm. |
| Dot Size (W x H) | 0.36 x 0.36 | mm. |
| Driving IC Package | COG | |

1.2 Display specification

| Display | Descriptions | Note |
|----------------------|----------------------|------|
| LCD Type | 5.7" TFT | |
| LCD Mode | Normal white | |
| Polarizer Mode | Transmissive | |
| Polarizer UV-Cutting | With | |
| Polarizer Surface | Normal | |
| Background Color | Black | |
| Backlight Type | LED | |
| Backlight Color | White | |
| Viewing Direction | 12 O'clock Direction | |

* Color tone is slightly changed by temperature and driving voltage.

1.3 Outline dimension

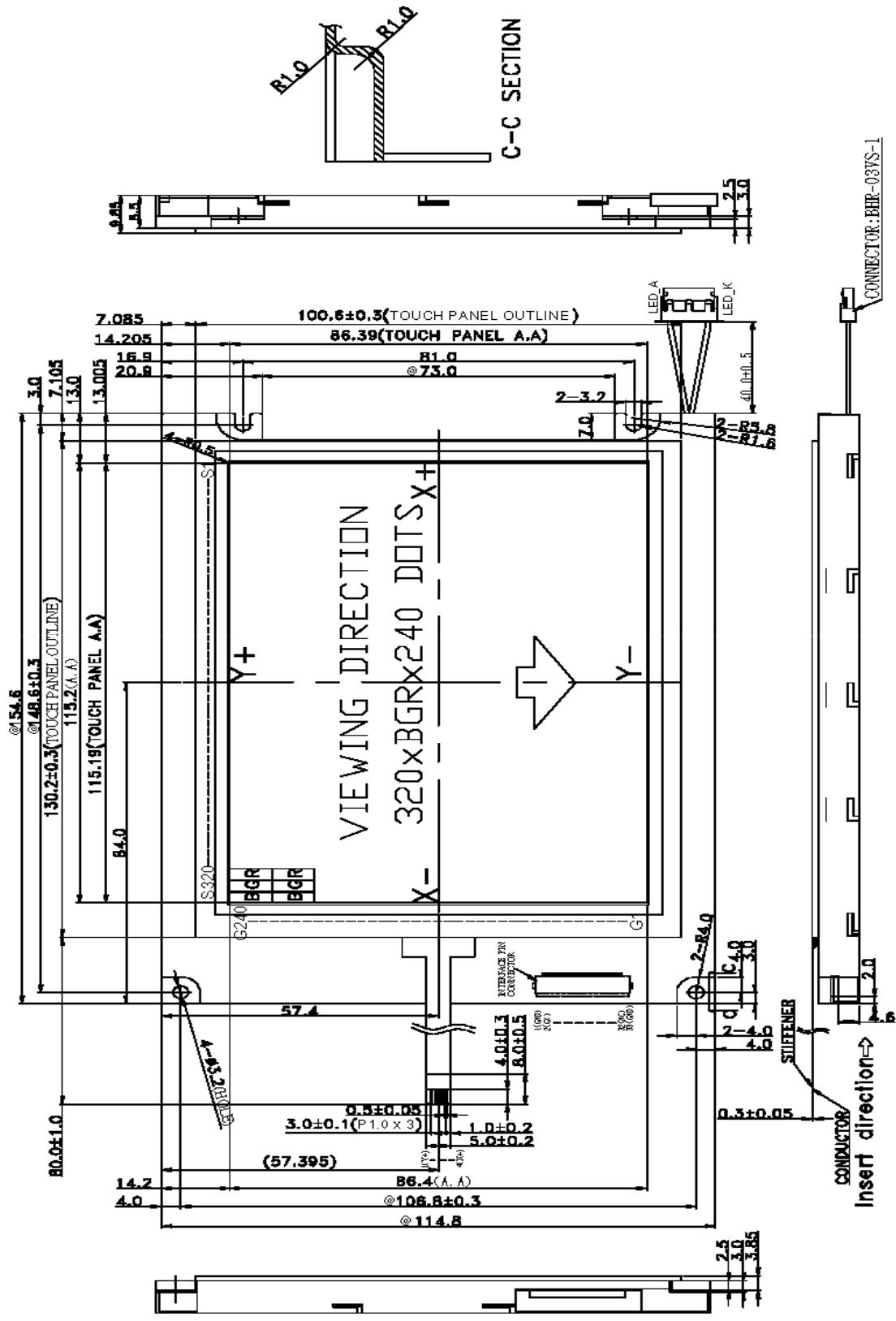

- NOTE:
- 1.LCD: TFT, TRANSMISSIVE MODE, NORMAL WHITE
 - 2.VIEWING DIRECTION: 12 O'CLOCK
 - 3.TOP: -20°C~70°C; TST: -30°C~80°C
 - 4.DRIVER IC: HX8218-A+HX8615-A
 - 5.TOLERANCE FOR NOT ASSIGNED: ±0.5 mm
 - 6."@": KEY DIMENSIONS
 - 7.TFT PIXEL SIZE: 120 x 360 um
 - 8.LED BACKLIGHT CONNECTORS: BHR-03YS-1
 - MATCHING CONNECTOR: SM02(8.0)B-BHS-1-TB(LF)(SN)
 - 9.INTERFACE PIN CONNECTOR: IMSA-9637S-33A-TB
 - 10.LED COLOR: WHITE; VLED=23.1V(TYP), IF=60.0mA(Constant Current)

Date : Apr. 12, 2007

TECHNICAL SPECIFICATION



LCM

HT5702UL-T

Page 4 of 21

1.4 Block diagram:

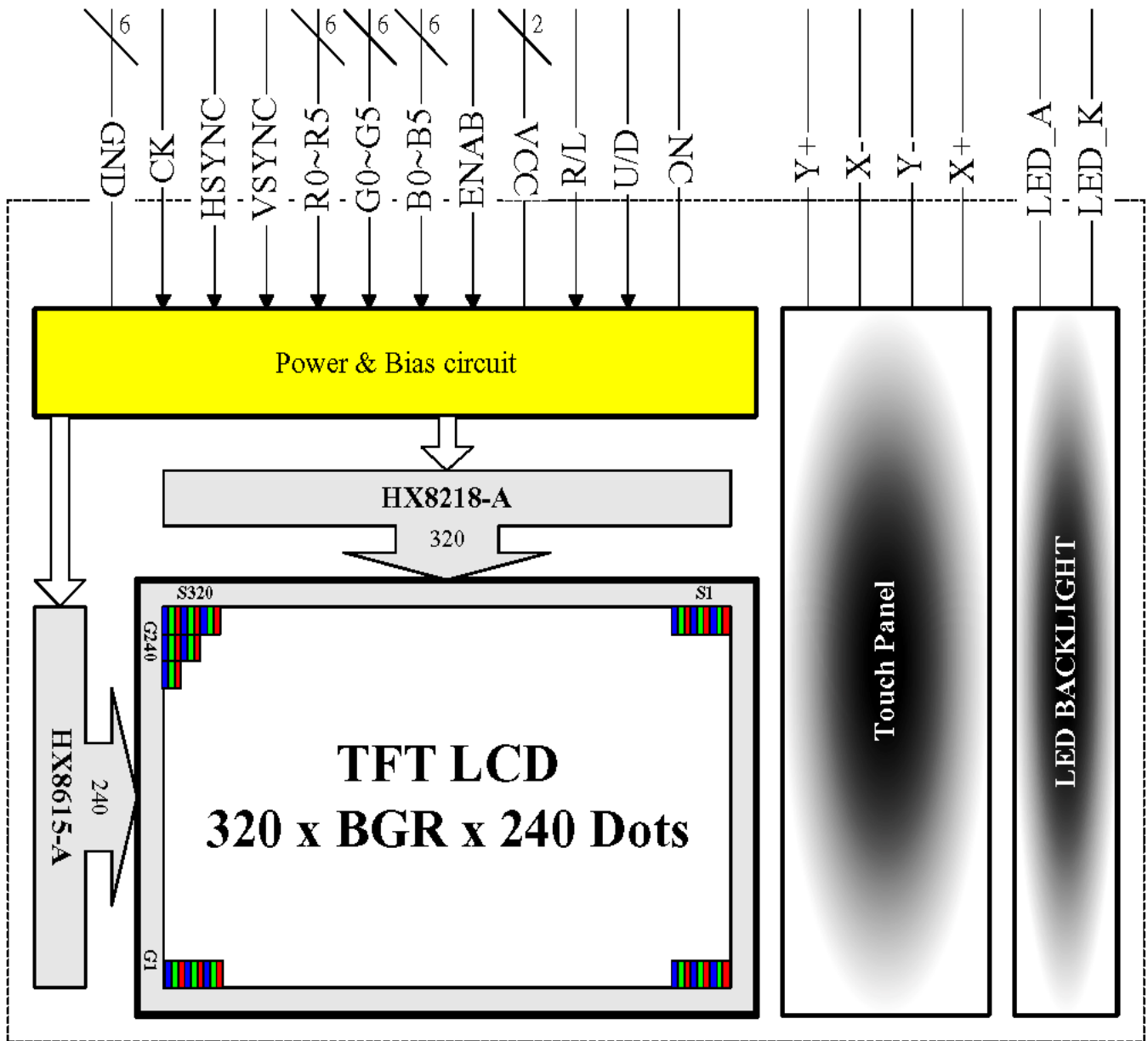

1.5 Interface pin :

| Pin No. | Pin Symbol | I/O | Description |
|---------|------------|-----|---|
| 1 | GND | P | Ground. (0V) |
| 2 | CK | I | Clock signal for sampling each data signal. |
| 3 | Hsync | I | Horizontal synchronous signal (Negative) |
| 4 | Vsync | I | Vertical synchronous signal (Negative) |
| 5 | GND | P | Ground. (0V) |
| 6-11 | R0-R5 | I | RED data signal. |
| 12 | GND | P | Ground. (0V) |
| 13-18 | G0-G5 | I | GREEN data signal. |
| 19 | GND | I | Ground. (0V) |
| 20-25 | B0-B5 | I | BLUE data signal. |
| 26 | GND | I | Ground. (0V) |
| 27 | ENAB | I | Signal to settle the horizontal display position (Positive). |
| 28,29 | VCC | P | +3.3V power supply. |
| 30 | R/L | I | Horizontal display mode select signal. L: Normal, H: Reverse. |
| 31 | U/D | I | Vertical display mode select signal. L: Normal, H: Reverse. |
| *32 | NC | - | No connect. |
| 33 | GND | P | Ground. (0V) |

*This pin doesn't support the V/Q mode as the NO.32 pin of sharp spec.

| | | | |
|---|----|---|---------------|
| 1 | Y+ | O | Touch screen. |
| 2 | X- | O | Touch screen. |
| 3 | Y- | O | Touch screen. |
| 4 | X+ | O | Touch screen. |

| | | | |
|---|-------|---|---------------------------------------|
| 1 | LED_A | P | Power supply input pin for backlight. |
| 2 | LED_K | P | Ground pin for backlight. |

Date : Apr. 12, 2007

TECHNICAL SPECIFICATION

HYES

LCM

HT5702UL-T

Page 6 of 21

2. ELECTRICAL CHARACTERISTICS

2.1 Absolute Maximum Ratings

| Items | Symbol | Min. | Max. | Unit |
|---------------------------|------------------|-------|---------|------|
| Power supply voltage | VCC | -0.3 | 7.0 | V |
| Power supply voltage | VDD | -0.3 | 7.0 | V |
| Power supply voltage | VGH | -0.3 | 32.0 | V |
| Power supply voltage | VEE | -22.0 | 0.3 | V |
| Power supply voltage | VGH-VEE | -0.3 | 45.0 | V |
| Logic Output Voltage | V _{out} | -0.3 | 7.0 | V |
| Input voltage | V _{in} | -0.3 | VDD+0.3 | V |
| Operate temperature range | T _{OP} | -20 | 70 | °C |
| Storage temperature range | T _{ST} | -30 | 80 | °C |

Date : Apr. 12, 2007

TECHNICAL SPECIFICATION



LCM

HT5702UL-T

Page 7 of 21

2.2 DC Characteristics

| Items | Symbol | Condition | Min. | Typ. | Max. | Unit |
|------------------------------|----------|------------------------|--------------|-------|--------------|------|
| Supply voltage (Logic) | V_{CC} | - | 3.0 | 3.3 | 3.6 | V |
| Input Voltage | V_L | L level | 0 | - | $0.3 V_{CC}$ | V |
| | V_H | H level | $0.7 V_{CC}$ | - | V_{CC} | V |
| LCM Recommend LCD | V_{GH} | $T_a=25^\circ\text{C}$ | - | 15.0 | - | V |
| Module Driving Voltage | V_{EE} | $T_a=25^\circ\text{C}$ | - | -10.0 | - | |
| Power Supply Current for LCM | I_{CC} | $V_{CC}=3.3\text{ V}$ | - | - | TBD | mA |

*NOTE1: Min. and Max. Voltage is mean within the range will has optimum contrast at $T_a:25^\circ\text{C}$

Typ. Voltage is specified as module driving condition: $T_a=25^\circ\text{C}, V_{OP}$ at Optimum Contrast, the measuring condition as below, this value is **HYES** recommend when customer change the set condition , the V_{LCD} will be change.

*NOTE2 :

Measuring Condition:

Standard Value MAX.

$T_a = 25^\circ\text{C}$

$V_{CC} - \text{GND} = 3.3\text{V}$

Display Pattern = Checkered pattern

2-2.1 Back-light only Specification

| PARAMETER | SYMBOL | MIN | TYP | MAX | Unit | Test Condition | NOTE |
|----------------|--------|------|-------|-----|-----------------|---|------|
| Supply Current | If | - | - | 60 | mA | $T_a=25^\circ\text{C}$ | - |
| Supply Voltage | Vf | - | 23.1 | - | V | $T_a=25^\circ\text{C}$ | - |
| Brightness | Br | 4300 | - | - | cd/m^2 | $T_a=25^\circ\text{C}$ $I_f=20\text{mA}$ | - |
| Half-Life Time | Lf | - | 10000 | - | hrs | $T_a=25^\circ\text{C}$ | 1 |

Note 1 : The " Half-Life Time "is defined as the module brightness decrease to 50% original brightness.

Date : Apr. 12, 2007

TECHNICAL SPECIFICATION

HYES

LCM

HT5702UL-T

Page 8 of 21

Digital Parallel RGB interface (960x240 resolution)

| PARAMETER | Symbol | Min. | Typ. | Max. | Unit | |
|--|-----------|-----------|-------|------|-----------|-------|
| CLK period | T_{OSC} | - | 156 | - | ns | |
| Data setup time | T_{SU} | 12 | - | - | ns | |
| Data hold time | T_{HD} | 12 | - | - | ns | |
| IHS period | T_H | - | 408 | - | T_{OSC} | |
| IHS pulse width | T_{HS} | 5 | 30 | - | T_{OSC} | |
| IHS rising time | T_{Cr} | - | - | 700 | ns | |
| IHS falling time | T_{Cf} | - | - | 300 | ns | |
| IVS pulse width | T_{VS} | 1 | 3 | 5 | T_H | |
| IVS rising time | T_{Vr} | - | - | 700 | ns | |
| IVS falling time | T_{Vf} | - | - | 1.5 | μs | |
| IVS falling to IHS rising time for odd field | T_{HVO} | 1 | - | - | T_{OSC} | |
| IVS falling to IHS falling time for even field | T_{HVE} | 1 | - | - | T_{OSC} | |
| IVS-DEN time | NTSC | T_{VSE} | - | 18 | - | T_H |
| | PAL | T_{VSE} | - | 26 | - | T_H |
| IHS-DEN time | T_{HE} | 36 | 68 | 88 | T_{OSC} | |
| DEN pulse width | T_{EP} | - | 320 | - | T_{OSC} | |
| DEN-STH time | T_{DES} | - | 1 | - | T_{OSC} | |
| IVS period | NTSC | - | 262.5 | - | T_H | |
| | PAL | - | 312.5 | - | T_H | |

Note:(1) When SYNC mode is used, 1st data start from 68th CLK after IHS falling.

www.DataSheet4U.com **2-4 Interface Timing Chart**

● **Digital Parallel RGB**

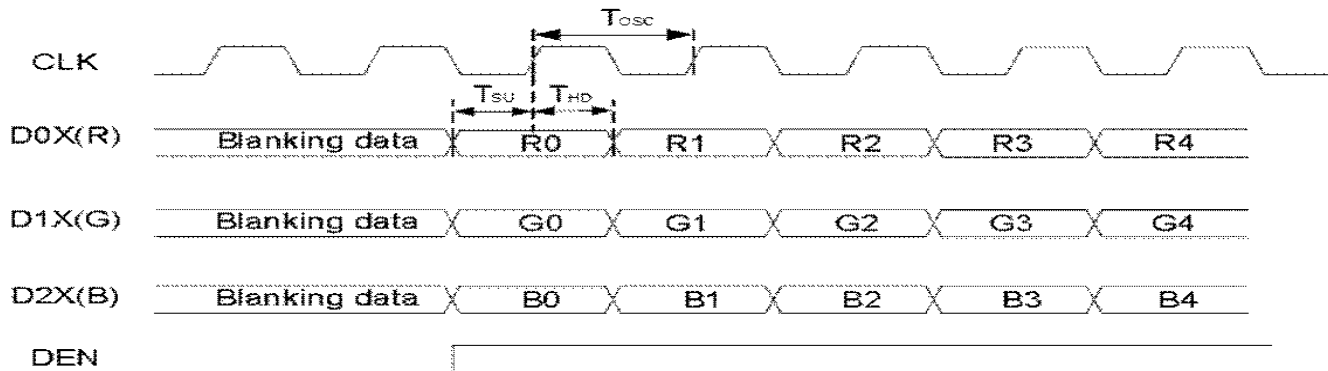

8.1.2.1 IHS and IVS timing

● **Odd field**

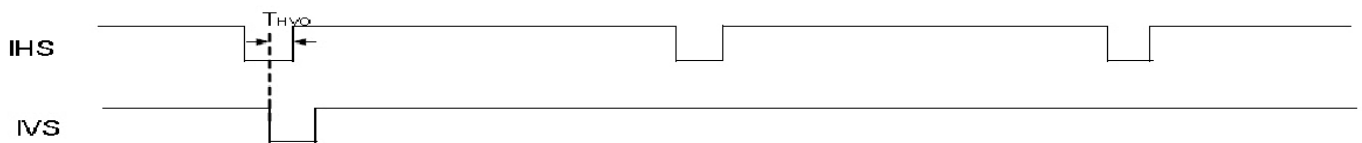

● **Even field**

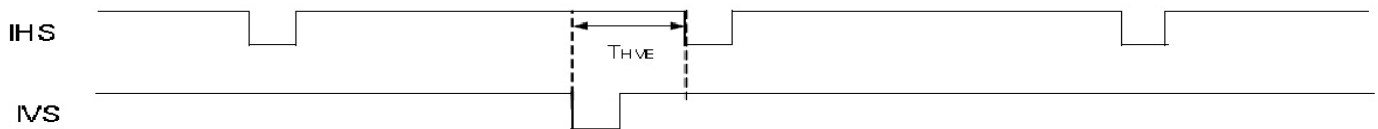

8.1.2.2 IHS and horizontal control timing waveform

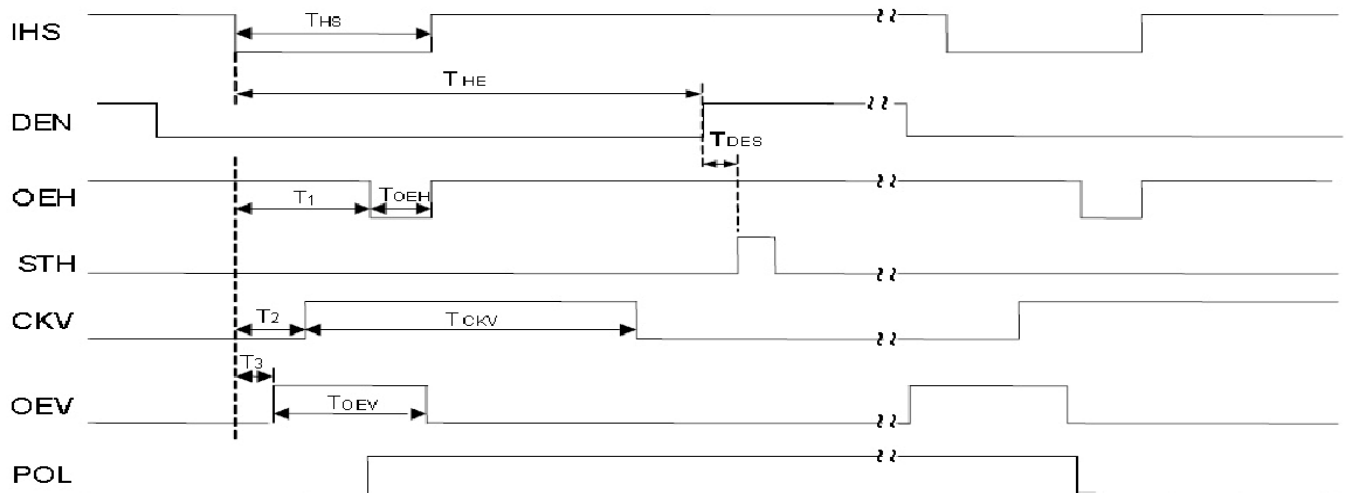

3. OPTICAL CHARACTERISTICS

3.1 Characteristics

Electrical and Optical Characteristics

| No. | Item | symbol / temp. | | Min. | Typ. | Max. | Unit | Note | |
|-----|-----------------------|----------------|------------|--------------------|------|------|------|--------|-------------------|
| 2 | Response Time | Tr | 25 °C | - | 15 | 30 | ms | 2 | |
| | | Tf | 25 °C | - | 35 | 50 | | | |
| 3 | Viewing Angle | Front-Rear | $\Theta 1$ | $\Phi = 270^\circ$ | -15 | - | 35 | degree | 3 |
| | | Left-Right | $\Theta 2$ | | -45 | - | 45 | | |
| 4 | Contrast Ratio | Cr | 25 °C | 150 | 250 | - | - | 4 | |
| 5 | Red x-code | Rx | 25 °C | TBD | TBD | TBD | - | 5 | |
| | Red y-code | Ry | | TBD | TBD | TBD | | | |
| | Green x-code | Gx | | TBD | TBD | TBD | | | |
| | Green y-code | Gy | | TBD | TBD | TBD | | | |
| | Blue x-code | Bx | | TBD | TBD | TBD | | | |
| | Blue y-code | By | | TBD | TBD | TBD | | | |
| | White x-code | Wx | | TBD | TBD | TBD | | | |
| | White y-code | Wy | | TBD | TBD | TBD | | | |
| | Brightness | Y | | - | - | - | | | cd/m ² |
| 6 | Brightness Uniformity | | 25 °C | - | - | - | % | 6 | |

Date : Apr. 12, 2007

TECHNICAL SPECIFICATION



LCM

HT5702UL-T

Page 11 of 21

3.2 Definition of optical characteristics

Measurement condition :

Transmissive and Transflective type

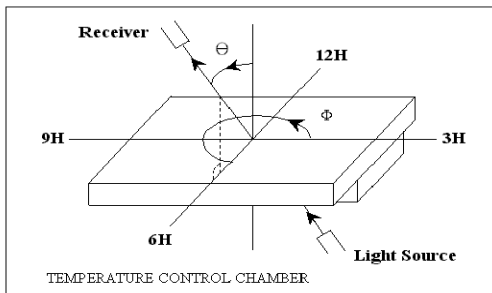

[Note 1] Definition of LCD Driving Vop and Waveform :

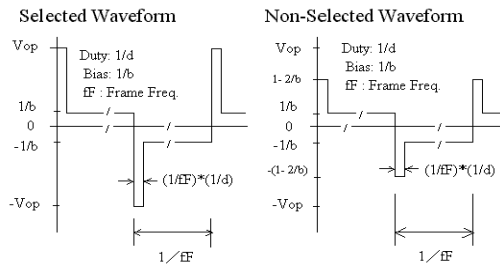
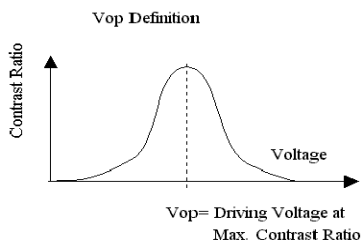

[Note 2] Definition of Response Time

for Positive type :

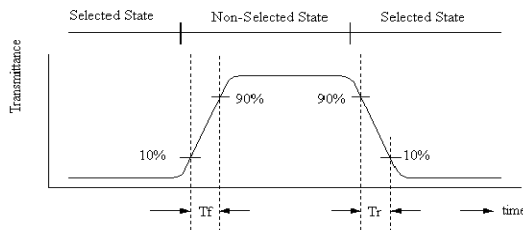

[Note 3] Definition of Viewing Angle :

[Note 4] Definition of Contrast Ratio :

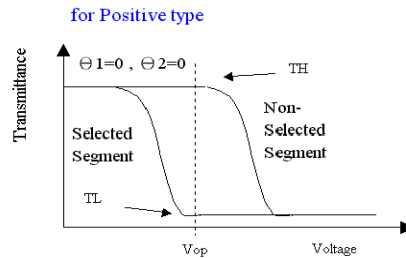
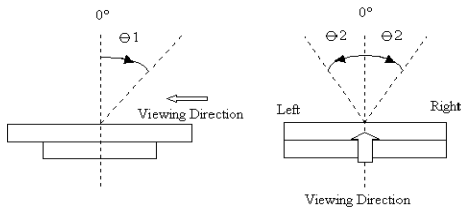

$$\text{Contrast Ratio} = \frac{TH}{TL}$$

Date : Apr. 12, 2007

TECHNICAL SPECIFICATION

HYES

LCM

HT5702UL-T

Page 12 of 21

[Note 5] Definition of measurement of Color Chromaticity and Brightness

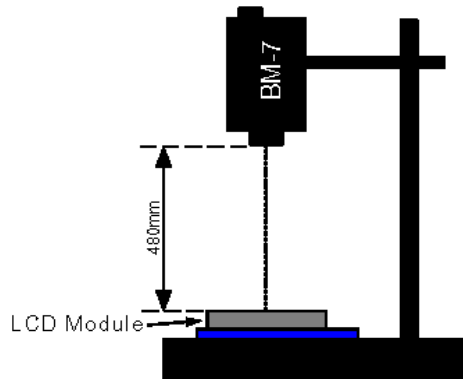

[Note 6] Definition of Brightness Uniformity

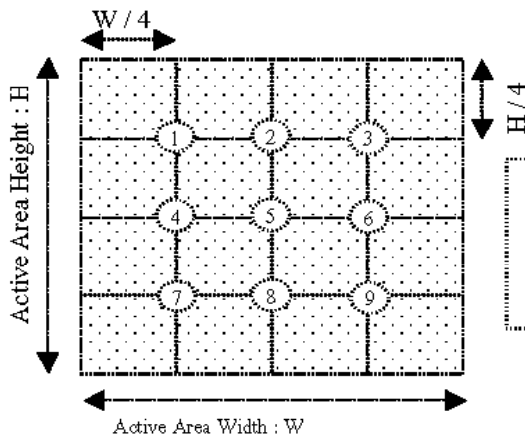

$$\text{Brightness Uniformity} = \frac{\text{Minimum Brightness of Point 1~9}}{\text{Maximum Brightness of Point 1~9}}$$

[Note 7] Definition of Measurement of Reflectance

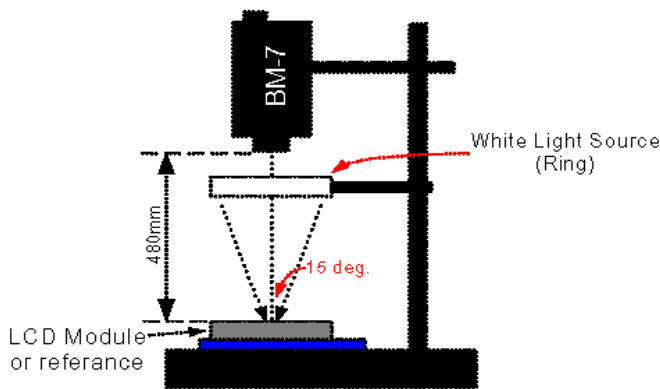

4. RELIABILITY :

| Item No | Items | Condition | Remark |
|---------|-------------------------------------|--|------------------------------------|
| 1 | High temperature operating | 70 °C , 200 hours | Finish product (With polarizer) |
| 2 | Low temperature operating | -20 °C , 200 hours | Finish product (With polarizer) |
| 3 | High temperature storage | 80 °C , 200 hours | Finish product (With polarizer) |
| 4 | Low temperature storage | -30 °C , 200 hours | Finish product (With polarizer) |
| 5 | High temperature & humidity storage | 60°C, 90%RH, 100 hours | Finish product (With polarizer) |
| 6 | Thermal Shock storage | -30°C , 30min.<=> 80°C , 30min. 10 Cycles | Finish product (With polarizer) |
| 7 | Vibration test | 10 => 55 =>10 => 55 => 10 Hz , within 1 minute Amplitude : 1.5mm. 15 minutes for each Direction (X,Y,Z) | Finish product (With polarizer) |
| 8 | Drop test | Packed, 100CM free fall, 6 sides, 1 corner, 3edges | Finish product (With polarizer) |
| 9 | Life time | 50,000 hours 25°C , 70%RH below , specification condition driving | Finish product (With polarizer) |

- * One single product test for only one item.
- * Judgment after test : keep in room temperature for more than 2 hours.
 - Current consumption < 2 times of initial value
 - Contrast > 1/2 initial value
 - Function : work normally

Date : Apr. 12, 2007

TECHNICAL SPECIFICATION

HYES

LCM

HT5702UL-T

Page 14 of 21

www.5. **PRODUCT HANDLING AND APPLICATION**

PRECAUTION FOR HANDLING LCM

- The LCD module contains a C-MOS LSI. People who operate the LCM should wear ESD protection equipment to prevent ESD hurt on products.
- Do not input any signal before power is turned on.
- Do not take LCM from its packaging bag until it is assembled.
- Peel off the LCM protective film slowly since static electricity may be generated.
- Pay attention to the humidity of the work shop, 50~60%RH is satisfactory.
- Use a non-leak iron for soldering LCM.
- Do not touch the display surface or connection terminals area with bare hands. Smudges on the display surface reduce the insulation between terminals.
- Cautions for soldering to LCM:
Condition for soldering I/O terminals:
Temperature at iron tip :280°C±10°C .
Soldering time : 3~4sec./ terminals.
Type of solder : Eutectic solder(rosin flux filled).

PRECAUTION IN USE OF LCD

- Do not contact or scratch the front surface and the contact pads of a LCD panel with hard materials such as metal or glass or with one's nail.
- To clean the surface , wipe it gently with soft cloth dampened by alcohol.
- Do not attempt to wipe off the contact pads.
- Keep LCD panels away from direct sunlight , also avoid them in high-temperature & high humidity environment for a long period.
- Do not drive LCD panels by DC voltage.
- Do not expose LCD panels to organic solvent.
- Liquid in LCD is hazardous substance. In case a contact with liquid crystal material is occurred, be sure to immediately wash such material away by soap and water.
- The polarizer is easily damaged and should be handle with special care. Don't press or rub it with hard objects.

PRECAUTION FOR STORING LCM

- To avoid degradation of the device , do not store the module under the conditions of direct sunlight , high temperature or high humidity . Keep the module in bags designed to prevent static electricity charging under low temperature / normal humidity conditions(avoid high temperature / high humidity and low temperature below 0°C)

USING ON MEDICAL CARE , SAFETY OR HAZARDOUS APPLICATION OR SYSTEM

- For the application in medical care, safety and hazardous products or systems, an authorization from HYES is required. HYES will not responsible for any damage or loss which caused by the products without any authorization given by HYES.
- This product is not allowed to be designed and used for military application and/or purpose.
- The delivery of this product to the countries and/or regions where the embargoes are imposed by U.N. is prohibited.

Date : Apr. 12, 2007

TECHNICAL SPECIFICATION

HYES

LCM

HT5702UL-T

Page 15 of 21

6. DATE CODE OF PRODUCTS

- Date code will be shown on each product :

- **Y MM DD - XXX**
| | | |
Year Month Day - Production lots

- Example: 2 1 2 2 3 - 0 0 3 ==>Year 2002, Dec.,23rd , Batch no.03

www.DataSheet4U.com
7. PACKING

Instruction of lot number:

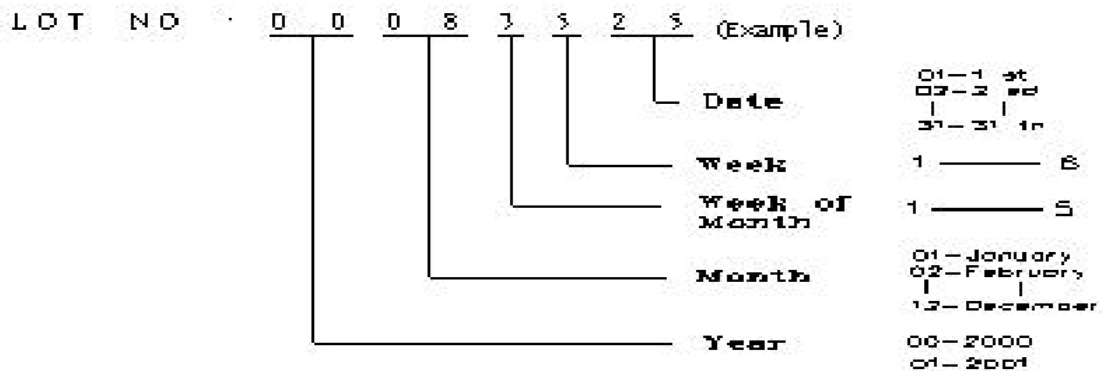

Label of carton:

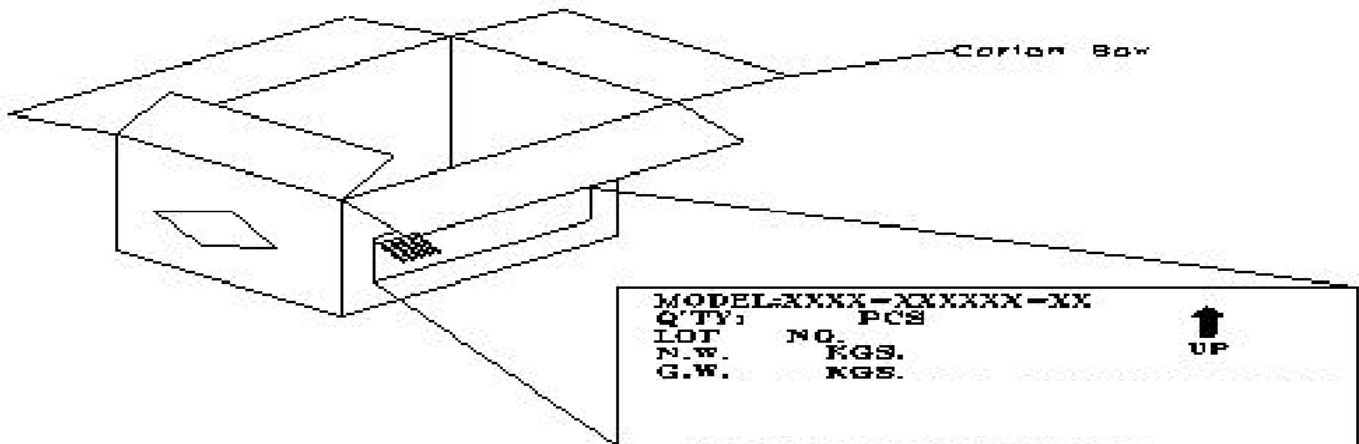

Packing tray must be stacked with alternated direction to each others.
 To tacks packing trays in same direction will cause product damaged.

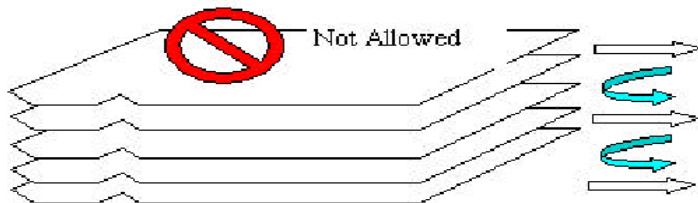
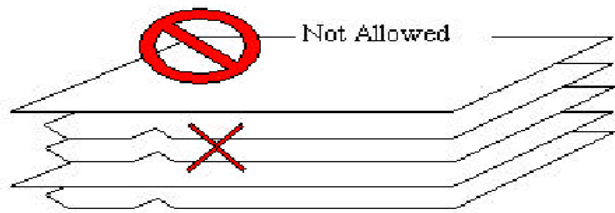

Date : Apr. 12, 2007

TECHNICAL SPECIFICATION

HYES

LCM

HT5702UL-T

Page 17 of 21

8. INSPECTION STANDARD

8.1. QUALITY :

THE QUALITY OF GOODS SUPPLIED TO PURCHASER SHALL COME UP TO THE FOLLOWING STANDARD.

8.1.1. THE METHOD OF PRESERVING GOODS

AFTER DELIVERY OF GOODS FROM **HYES** TO PURCHASER. PURCHASER SHALL CONTROL THE LCM AT -10 °C ~ 40 °C ,AND IT MIGHT BE DESIRABLE TO KEEP AT THE NORMAL ROOM TEMPERATURE AND HUMIDITY UNTIL INCOMING INSPECTION OR THROWING INTO PROCESS LINE.

8.1.2. INCOMING INSPECTION

(A) THE METHOD OF INSPECTION

IF PURCHASER MAKE AN INCOMING INSPECTION , A SAMPLING PLAN SHALL BE APPLIED ON THE CONDITION THAT QUALITY OF ONE DELIVERY SHALL BE REGARDED AS ONE LOT.

(B) THE STANDARD OF QUALITY

ISO-2859-1 (or MIL-STD-105D) , LEVEL II SINGLE PLAN.

| CLASS | AQL(%) |
|----------|--------|
| CRITICAL | 0.4 % |
| MAJOR | 0.65 % |
| MINOR | 1.5 % |
| TOTAL | 1.5 % |

EVERY ITEM SHALL BE INSPECTED ACCORDING TO THE CLASS.

(C) MEASURE

IF AS THE RESULT OF ABOVE RECEIVING INSPECTION , A LOT OUT IS DISCOVERED. PURCHASER SHALL BE INFORM SELLER OF IT WITHIN SEVEN DAYS. BUT FIRST SHIPMENT WITHIN FOURTEEN DAYS.

8.1.3. WARRANTY POLICY

HYES WILL PROVIDE ONE-YEAR WARRANTY FOR THE PRODUCTS ONLY IF UNDER SPECIFICATION OPERATING CONDITIONS. **HYES** WILL REPLACE NEW PRODUCTS FOR THESE DEFECT PRODUCTS WHICH UNDER WARRANTY PERIOD AND BELONG TO THE RESPONSIBILITY OF **HYES**.

8.2. CHECKING CONDITION

8.2.1. CHECKING DIRECTION SHALL BE IN THE 45 DEGREE AREA TO FACE THE SAMPLE.

8.2.2. CHECKER SHALL SEE OVER 30 cm. WITH BARE EYES FAR FROM SAMPLE AND USING 2 PCS. OF 20W FLUORESCENT LAMP.

Date : Apr. 12, 2007

TECHNICAL SPECIFICATION

HYES

LCM

HT5702UL-T

Page 18 of 21

8.3. INSPECTION PLAN :

| CLASS | ITEM | JUDGEMENT | CLASS |
|-----------------------|---|--|----------|
| PACKING & INDICATE | 1. OUTSIDE AND INSIDE PACKAGE | "MODEL NO." , "LOT NO." AND "QUANTITY" SHOULD INDICATE ON THE PACKAGE. | Minor |
| | 2. MODEL MIXED AND QUANTITY | OTHER MODEL MIXED.....REJECTED QUANTITY SHORT OR OVER.....REJECTED | Critical |
| | 3. PRODUCT INDICATION | "MODEL NO." SHOULD INDICATE ON THE PRODUCT | Major |
| ASSEMBLY | 4. DIMENSION, LCD GLASS SCRATCH AND SCRIBE DEFECT. | ACCORDING TO SPECIFICATION OR DRAWING. | Major |
| APPEARANCE | 5. VIEWING AREA | POLARIZER EDGE OR LCD'S SEALING LINE IS VISABLE IN THE VIEWING AREAREJECTED | Minor |
| | 6. BLEMISH , BLACK SPOT , WHITE SPOT IN THE LCD AND LCD GLASS CRACKS | ACCORDING TO STANDARD OF VISUAL INSPECTION (INSIDE VIEWING AREA) | Minor |
| | 7. BLEMISH , BLACK SPOT WHITE SPOT AND SCRATCH ON THE POLARIZER | ACCORDING TO STANDARD OF VISUAL INSPECTION (INSIDE VIEWING AREA) | Minor |
| | 8. BUBBLE IN POLARIZER | ACCORDING TO STANDARD OF VISUAL INSPECTION (INSIDE VIEWING AREA) | Minor |
| | 9. LCD'S RAINBOW COLOR | STRONG DEVIATION COLOR (OR NEWTON RING) OF LCD.....REJECTED. OR ACCORDING TO LIMITED SAMPLE (IF NEEDED, AND INSIDE VIEWING AREA) | Minor |
| ELECTRICAL | 10. ELECTRICAL AND OPTICAL CHARACTERISTICS (CONTRAST , VOP , CHROMATICITY ... ETC) | ACCORDING TO SPECIFICATION OR DRAWING . (INSIDE VIEWING AREA) | Critical |
| | 11. MISSING PATTERN | MISSING DOT , LINE , CHARACTERREJECTED | Critical |
| | 12. SHORT CIRCUIT , WRONG PATTERN DISPLAY | NON DISPLAY , WRONG PATTERN DISPLAY , CURRENT CONSUMPTION OUT OF SPECIFICATION..... REJECTED | Critical |
| | 13. PIN HOLE , PATTERN DEFORMITY | ACCORDING TO STANDARD OF VISUAL INSPECTION | Minor |

Date : Apr. 12, 2007

TECHNICAL SPECIFICATION

HYES

LCM

HT5702UL-T

Page 19 of 21

8.4. STANDARD OF VISUAL INSPECTION

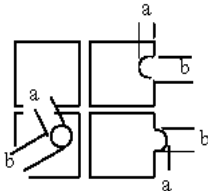
| NO. | CLASS | ITEM | JUDGEMENT | | | | | | | | | | | | | | | | | | | | | | | | | |
|------------------------|----------------------|--|---|----------------|-----------------|------------------|-----------|------------------------|---|------------------------|---|---------------|---|--------|-------|-----------------|-------|---------------|-----------|--------------|----------------------|---|--------------|----------------------|---|-------|------------|-------------------|
| 8.4.1 | MINOR | · BLEMISH · BLACK SPOT · WHITE SPOT IN THE LCD. · BLEMISH · BLACK SPOT · WHITE SPOT AND SCRATCH ON THE POLARIZER | (A) ROUND TYPE: unit : mm. <table border="1"> <thead> <tr> <th>DIAMETER (mm.)</th> <th>ACCEPTABLE Q'TY</th> </tr> </thead> <tbody> <tr> <td>$\Phi \leq 0.1$</td> <td>DISREGARD</td> </tr> <tr> <td>$0.1 < \Phi \leq 0.2$</td> <td>2</td> </tr> <tr> <td>$0.2 < \Phi \leq 0.25$</td> <td>1</td> </tr> <tr> <td>$0.25 < \Phi$</td> <td>0</td> </tr> </tbody> </table> NOTE: $\Phi = (\text{LENGTH} + \text{WIDTH})/2$ (B) LINER TYPE: unit : mm. <table border="1"> <thead> <tr> <th>LENGTH</th> <th>WIDTH</th> <th>ACCEPTABLE Q'TY</th> </tr> </thead> <tbody> <tr> <td>-----</td> <td>$W \leq 0.03$</td> <td>DISREGARD</td> </tr> <tr> <td>$L \leq 5.0$</td> <td>$0.03 < W \leq 0.05$</td> <td>3</td> </tr> <tr> <td>$L \leq 5.0$</td> <td>$0.05 < W \leq 0.07$</td> <td>1</td> </tr> <tr> <td>-----</td> <td>$0.07 < W$</td> <td>FOLLOW ROUND TYPE</td> </tr> </tbody> </table> | DIAMETER (mm.) | ACCEPTABLE Q'TY | $\Phi \leq 0.1$ | DISREGARD | $0.1 < \Phi \leq 0.2$ | 2 | $0.2 < \Phi \leq 0.25$ | 1 | $0.25 < \Phi$ | 0 | LENGTH | WIDTH | ACCEPTABLE Q'TY | ----- | $W \leq 0.03$ | DISREGARD | $L \leq 5.0$ | $0.03 < W \leq 0.05$ | 3 | $L \leq 5.0$ | $0.05 < W \leq 0.07$ | 1 | ----- | $0.07 < W$ | FOLLOW ROUND TYPE |
| DIAMETER (mm.) | ACCEPTABLE Q'TY | | | | | | | | | | | | | | | | | | | | | | | | | | | |
| $\Phi \leq 0.1$ | DISREGARD | | | | | | | | | | | | | | | | | | | | | | | | | | | |
| $0.1 < \Phi \leq 0.2$ | 2 | | | | | | | | | | | | | | | | | | | | | | | | | | | |
| $0.2 < \Phi \leq 0.25$ | 1 | | | | | | | | | | | | | | | | | | | | | | | | | | | |
| $0.25 < \Phi$ | 0 | | | | | | | | | | | | | | | | | | | | | | | | | | | |
| LENGTH | WIDTH | ACCEPTABLE Q'TY | | | | | | | | | | | | | | | | | | | | | | | | | | |
| ----- | $W \leq 0.03$ | DISREGARD | | | | | | | | | | | | | | | | | | | | | | | | | | |
| $L \leq 5.0$ | $0.03 < W \leq 0.05$ | 3 | | | | | | | | | | | | | | | | | | | | | | | | | | |
| $L \leq 5.0$ | $0.05 < W \leq 0.07$ | 1 | | | | | | | | | | | | | | | | | | | | | | | | | | |
| ----- | $0.07 < W$ | FOLLOW ROUND TYPE | | | | | | | | | | | | | | | | | | | | | | | | | | |
| 8.4.2 | MINOR | BUBBLE IN POLARIZER | unit : mm. <table border="1"> <thead> <tr> <th>DIAMETER</th> <th>ACCEPTABLE Q'TY</th> </tr> </thead> <tbody> <tr> <td>$\Phi \leq 0.15$</td> <td>DISREGARD</td> </tr> <tr> <td>$0.15 < \Phi \leq 0.5$</td> <td>2</td> </tr> <tr> <td>$0.5 < \Phi$</td> <td>0</td> </tr> </tbody> </table> | DIAMETER | ACCEPTABLE Q'TY | $\Phi \leq 0.15$ | DISREGARD | $0.15 < \Phi \leq 0.5$ | 2 | $0.5 < \Phi$ | 0 | | | | | | | | | | | | | | | | | |
| DIAMETER | ACCEPTABLE Q'TY | | | | | | | | | | | | | | | | | | | | | | | | | | | |
| $\Phi \leq 0.15$ | DISREGARD | | | | | | | | | | | | | | | | | | | | | | | | | | | |
| $0.15 < \Phi \leq 0.5$ | 2 | | | | | | | | | | | | | | | | | | | | | | | | | | | |
| $0.5 < \Phi$ | 0 | | | | | | | | | | | | | | | | | | | | | | | | | | | |
| 8.4.3 | MINOR | PIN HOLE · PATTERN DEFORMITY | unit : mm.  <table border="1"> <thead> <tr> <th>DIAMETER</th> <th>ACC. Q'TY</th> </tr> </thead> <tbody> <tr> <td>$\Phi \leq 0.1$</td> <td>DISREGARD</td> </tr> <tr> <td>$0.1 < \Phi \leq 0.25$</td> <td>3</td> </tr> <tr> <td>$0.25 < \Phi$</td> <td>0</td> </tr> </tbody> </table> | DIAMETER | ACC. Q'TY | $\Phi \leq 0.1$ | DISREGARD | $0.1 < \Phi \leq 0.25$ | 3 | $0.25 < \Phi$ | 0 | | | | | | | | | | | | | | | | | |
| DIAMETER | ACC. Q'TY | | | | | | | | | | | | | | | | | | | | | | | | | | | |
| $\Phi \leq 0.1$ | DISREGARD | | | | | | | | | | | | | | | | | | | | | | | | | | | |
| $0.1 < \Phi \leq 0.25$ | 3 | | | | | | | | | | | | | | | | | | | | | | | | | | | |
| $0.25 < \Phi$ | 0 | | | | | | | | | | | | | | | | | | | | | | | | | | | |

Date : Apr. 12, 2007

TECHNICAL SPECIFICATION

HYES

LCM

HT5702UL-T

Page 20 of 21

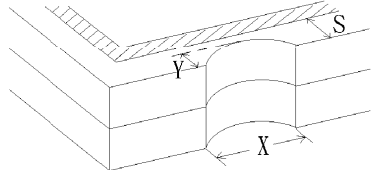
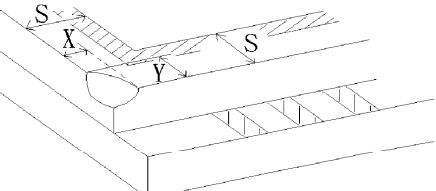
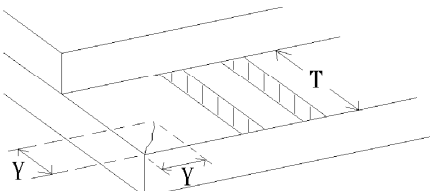
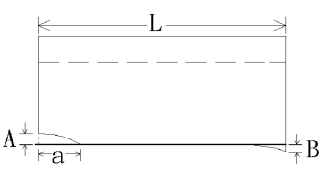
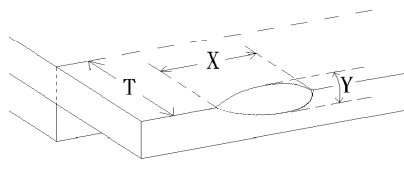
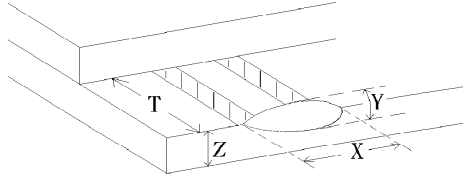
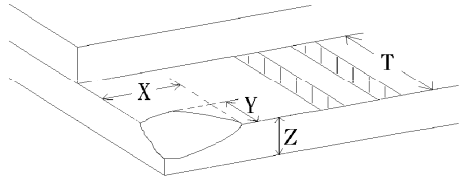
| NO. | CLASS | ITEM | JUDGEMENT |
|--------|-------|---|---|
| 8.4.4 | MINOR | CHIPPING |  $Y > S$ REJ. |
| 8.4.5 | MINOR | CHIPPING |  $X \text{ or } Y > S$ REJ. |
| 8.4.6 | MAJOR | GLASS CRACK |  $Y > (1/2) T$ REJ. |
| 8.4.7 | MAJOR | SCRIBE DEFECT |  <ol style="list-style-type: none"> $a > L/3$, $A > 1.5\text{mm}$. REJ. B : ACCORDING TO DIMENSION |
| 8.4.8 | MINOR | CHIPPING (ON THE TERMINAL AREA) |  $\Phi = (x+y)/2 > 2.5 \text{ mm}$ REJ. |
| 8.4.9 | MINOR | CHIPPING (ON THE TERMINAL SURFACE) |  $Y > (1/3) T$ REJ. |
| 8.4.10 | MINOR | CHIPPING |  $Y > T$ REJ. |

Date : Apr. 12, 2007

TECHNICAL SPECIFICATION

HYES

LCM

HT5702UL-T

Page 21 of 21