

# APPROVAL

PART NO.	DESCRIPTION	REMARKS
<b>HT5711L</b>	<b>LCD MODULE</b> (640 x RGB x 480)	<b>* ROHS compliant</b>

CUSTOMER APPLICATION P/N	
APPROVED BY	
DATE	

PLEASE KINDLY FIND AND APPROVE THE SPECIFICATIONS INSERTED  
HEREIN AND RETURN ONE COPY HERE OF WITH YOUR SIGNATURE OF APPROVAL.

PERPARED BY	CHECKED BY	CONFIRMED BY



**HYES Optoelectronics, Inc.**

2000 Wyatt Drive Suite 6  
Santa Clara, CA 95054 USA

**CONTENTS:**

No.	Item
1	<b>BASIC SPECIFICATION</b> 1.1 Mechanical Specification 1.2 Display Specification 1.3 Outline Dimension 1.4 Block Diagram 1.5 Interface Pin
2	<b>ELECTRICAL CHARACTERISTICS</b> 2.1 Absolute Maximum Ratings 2.2 DC Characteristics 2.3 AC Characteristics 2-4 Interface Timing Chart
3	<b>OPTICAL CHARACTERISTICS</b> 3.1 Condition 3.2 Definition of Optical Characteristics
4	<b>RELIABILITY</b>
5	<b>PRODUCT HANDLING AND APPLICATION</b>
6	<b>DATECODE</b>
7	<b>PACKING &amp; LOTNO</b>
8	<b>INSPECTION STANDARD</b>

Date : Jan. 07, 2009

TECHNICAL SPECIFICATION

**HYES**

LCM

HT5711L

Page 2 of 22

## 1. BASIC SPECIFICATION

### 1.1 Mechanical specifications

Items	Nominal Dimension	Unit
Active screen size	5.7" diagonal	-
Dot Matrix	640*RGB*480	Pixel
Module Size (W x H x T)	127.0 x 98.43 x 8.96	mm.
Active Area (W x H)	115.2 x 86.4	mm.
Dot Size (W x H)	0.18 x 0.18	mm.
Color depth	262K	color
Interface	Parallel 18-bit RGB	-
Driving IC Package	COG	-

### 1.2 Display specification

Display	Descriptions	Note
LCD Type	a-Si TFT	
LCD Mode	TN/Normal white	
Polarizer Mode	Transmissive	
Polarizer Surface	Normal	
Pixel arrangement	RGB-stripe	
Backlight Type	LED	
Viewing Direction	6 O'clock Direction	

\* Color tone is slightly changed by temperature and driving voltage.

Date : Jan. 07, 2009

TECHNICAL SPECIFICATION

**HYES**

LCM

HT5711L

Page 3 of 22

### 1.3 Outline dimension

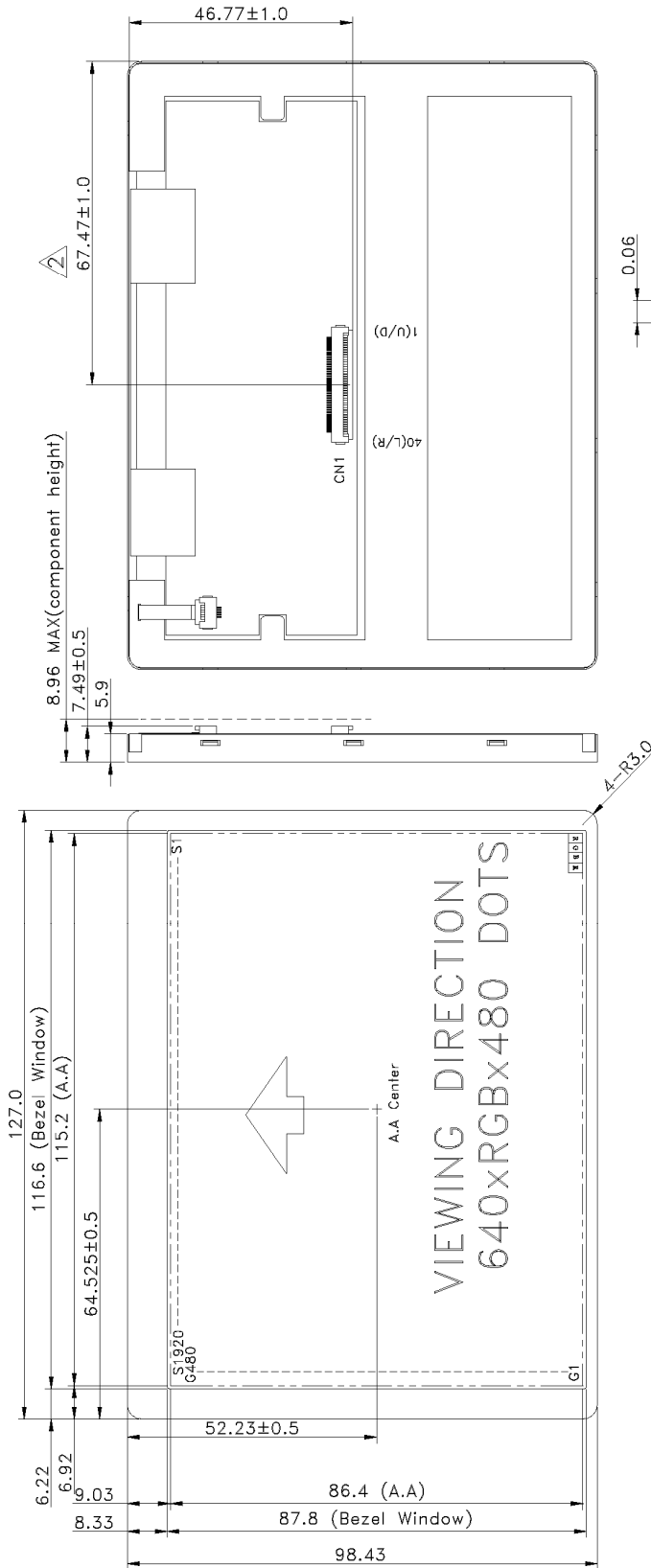

- NOTE :
1. LCD : TFT TRANSMISSIVE TYPE , NORMAL WHITE
  2. VIEWING DIRECTION : 6 O'CLOCK
  3. Top : -20~70°C , Tst : -30~80°C
  4. LED BACKLIGHT COLOR : WHITE
  5. CONSTANT VOLTAGE FOR LED DRIVER : VLED=5.0 V, ILED=340.0mA(TYP.)
  6. BRIGHTNESS : 210 cd/m<sup>2</sup> (MIN), 300 cd/m<sup>2</sup> (TYP)
  7. TOLERANCE FOR NOT ASSIGNED : ±0.3mm
  8. RoHS-COMPLIANT
  9. CN1 : 6705-E40N-00R(E&T)

Date : Jan. 07, 2009

TECHNICAL SPECIFICATION



LCM

HT5711L

Page 4 of 22

**1.4 Block diagram:**

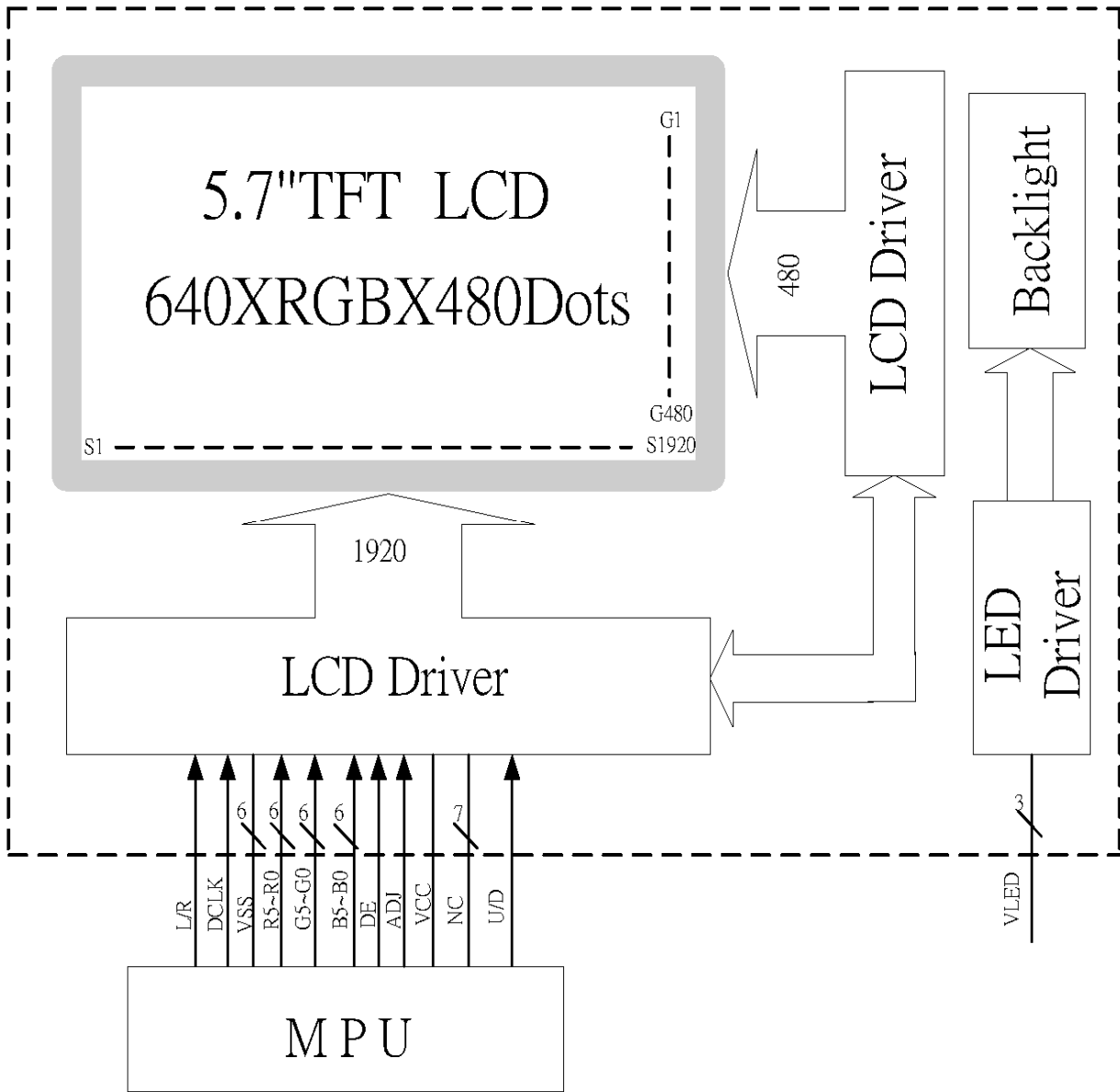

Date : Jan. 07, 2009

TECHNICAL SPECIFICATION

**HYES**

LCM

HT5711L

Page 5 of 22

**1.5 Interface pin :**

Pin No.	Pin Symbol	I/O	Description
1	U/D	I	Up or Down Display Control
2~3	NC	-	Customer non-connect.
4~6	VLED	P	Power supply for digital circuit LED.(+5.0V)
7	VCC	P	Power supply for digital circuit LCD. (+3.3V)
8	NC	-	Customer non-connect.
9	DE	I	Data enable
10	NC	-	Customer non-connect.
11	NC	-	Customer non-connect.
12	NC	-	Customer non-connect.
13	B5	I	Blue data input (MSB)
14、15	B4、B3	I	Blue data input
16	VSS	P	Power ground
17、18	B2、B1	I	Blue data input
19	B0	I	Blue data input (LSB)
20	VSS	P	Power ground
21	G5	I	Green data input (MSB)
22、23	G4、G3	I	Green data input
24	VSS	P	Power ground
25、26	G2、G1	I	Green data input
27	G0	I	Green data input (LSB)
28	VSS	P	Power ground
29	R5	I	Red data input (MSB)
30、31	R4、R3	I	Red data input
32	VSS	P	Power ground
33、34	R2、R1	I	Red data input
35	R0	I	Red data input (LSB)
36	NC	-	Customer non-connect.
37	NC	-	Customer non-connect.
38	DCLK	I	Clock signals.
39	VSS	P	Power ground
40	L/R	I	Left or Right Display Control

Date : Jan. 07, 2009

TECHNICAL SPECIFICATION

**HYES**

LCM

HT5711L

Page 6 of 22

## 2. ELECTRICAL CHARACTERISTICS

### 2.1 Absolute Maximum Ratings

Items	Symbol	Min.	Max.	Unit
Power supply voltage	VCC	-0.3	7.0	V
Input voltage	V <sub>in</sub>	-0.3	VCC+0.3	V
Operate temperature range	T <sub>OP</sub>	-20	70	°C
Storage temperature range	T <sub>ST</sub>	-30	80	°C

Date : Jan. 07, 2009

TECHNICAL SPECIFICATION



LCM

HT5711L

Page 7 of 22

## 2.2 DC Characteristics

 $T_a = 25^\circ\text{C}$ 

Items	Symbol	Min.	Typ.	Max.	Unit	Condition
Supply voltage	$V_{CC}$	-	3.3	-	V	-
Input Voltage	$V_{IL}$	0	-	$0.3V_{CC}$	V	L level
	$V_{IH}$	$0.7V_{CC}$	-	$V_{CC}$	V	H level
Current consumption	$I_{CC}$	-	-	135	mA	Note 1

\*Note1 :

Measuring Condition:

Standard Value MAX.

$T_a = 25^\circ\text{C}$

$V_{CC} - GND = 3.3V$

Display Pattern = Check pattern

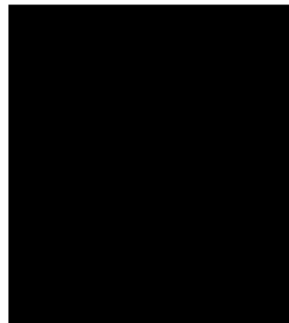

0 gray black pattern

### 2-2.1 Back-light Characteristics

PARAMETER	SYMBOL	MIN	TYP	MAX	Unit	Test Condition	NOTE
Supply Current	$I_{LED}$	-	340	680	mA	$T_a = 25^\circ\text{C}$	-
Supply Voltage	$V_{LED}$	-	5	-	V	$T_a = 25^\circ\text{C}$	-
Half-Life Time	Lf	-	10000	-	hrs	$T_a = 25^\circ\text{C}$	1

Note 1 : The " Half-Life Time "is defined as the module brightness decrease to 50% original brightness.

Date : Jan. 07, 2009

TECHNICAL SPECIFICATION

**HYES**

LCM

HT5711L

Page 8 of 22



## 2.3 AC Characteristics

### Digital Parallel RGB interface (1920x480 resolution)

PARAMETER	Symbol	Spec.			Unit
		Min.	Typ.	Max.	
CLK frequency	$F_{CPH}$	-	25.175	-	MHz
CLK period	$T_{CPH}$	-	39.7	-	ns
CLK pulse duty	$T_{CWH}$	40	50	60	%
HS period	$T_H$	-	800	-	$T_{CPH}$
HS pulse width	$T_{WH}$	5	30	-	$T_{CPH}$
HS-first horizontal data time	$T_{HS}$	112	144	175	$T_{CPH}$
DEN pulse width	$T_{EP}$	-	640	-	$T_{CPH}$
VS pulse width	$T_{WV}$	1	3	5	$T_H$
VS-DEN time	$T_{STV}$	-	35	-	$T_H$
VS period	$T_V$	-	525	-	$T_H$

**Note:** When SYNC mode is used, 1st data start from 144th CLK after HS falling (when  $STHD[5:0]=00000$ )

PARAMETER	Symbol	Spec.			Unit
		Min.	Typ.	Max.	
OEV pulse width	$T_{OEV}$	-	100	-	$T_{CPH}$
CKV pulse width	$T_{CKV}$	-	96	-	$T_{CPH}$
HS-CKV time	$T_1$	-	52	-	$T_{CPH}$
HS-OEV time	$T_2$	-	8	-	$T_{CPH}$
HS-POL time	$T_3$	-	72	-	$T_{CPH}$
STV setup time	$T_{SUV}$	-	46	-	$T_{CPH}$
STV pulse width	$T_{WSTV}$	-	1	-	$T_H$

Date : Jan. 07, 2009

TECHNICAL SPECIFICATION



LCM

HT5711L

Page 9 of 22

## 2-4 Interface Timing Chart

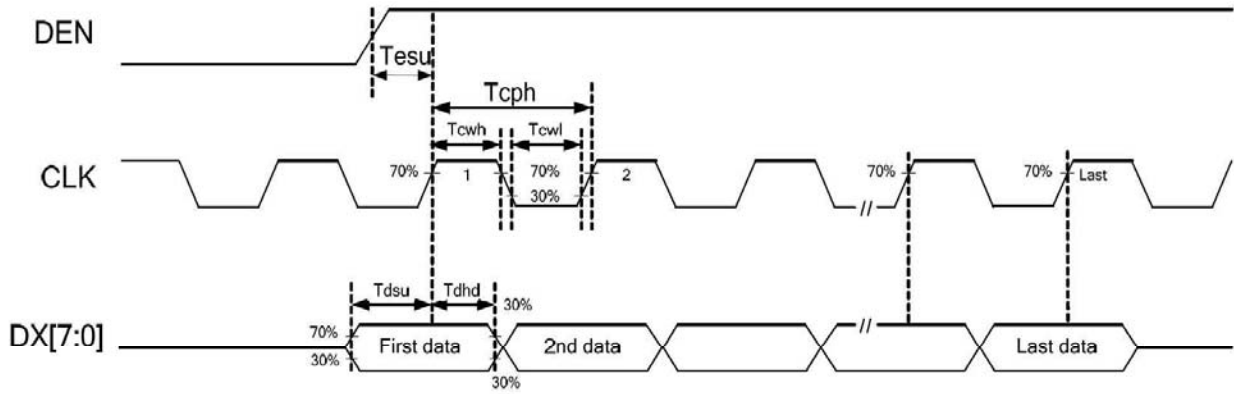

### 2-4-1 Data input format for RGB Mode

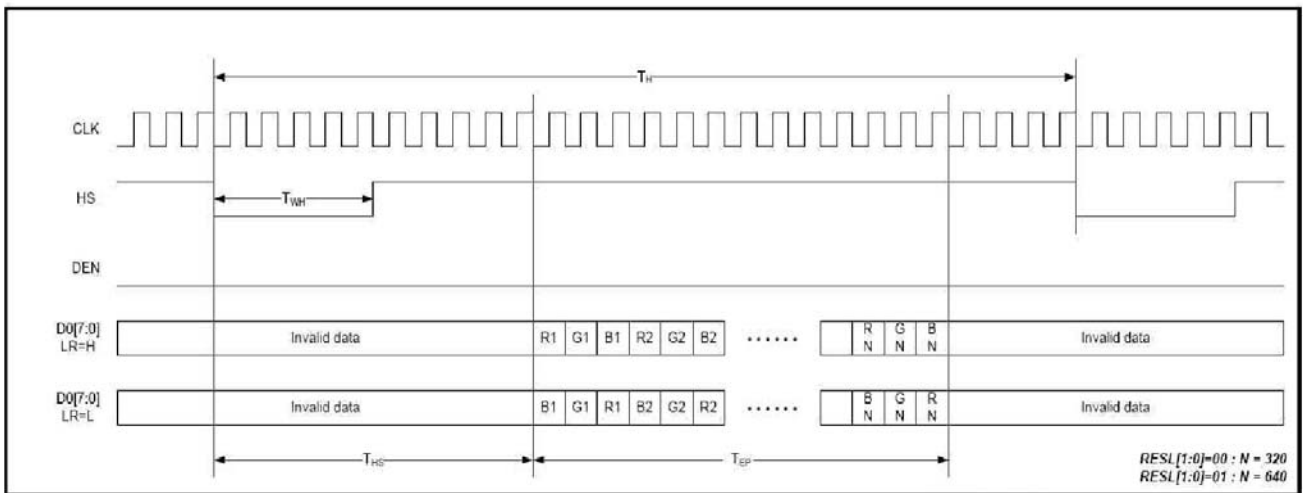

### 3. OPTICAL CHARACTERISTICS

#### 3.1 Characteristics

Electrical and Optical Characteristics

No.	Item	symbol / temp.	Min.	Typ.	Max.	Unit	Note	
1	Response Time	Tr	25 °C	-	15	ms	2	
		Tf	25 °C	-	35			
2	Viewing Angle	Hor.	$\Theta_{x+}$	Center CR>=10	-	60	degree	3
			$\Theta_{x-}$		-	60		
		Ver.	$\Theta_{y+}$		-	45		
			$\Theta_{y-}$		-	60		
3	Contrast Ratio	Cr	25 °C	250	350	-	-	4
4	Red x-code	Rx	25 °C	0.57	0.62	0.67	-	5
	Red y-code	Ry		0.31	0.36	0.41		
	Green x-code	Gx		0.28	0.33	0.38		
	Green y-code	Gy		0.53	0.58	0.63		
	Blue x-code	Bx		0.09	0.14	0.19		
	Blue y-code	By		0.08	0.13	0.18		
	White x-code	Wx		0.28	0.33	0.38		
	White y-code	Wy		0.32	0.37	0.42		
	Brightness	Y		210	300	-		
5	Brightness Uniformity		25°C	80	-	-	%	6

Date : Jan. 07, 2009

TECHNICAL SPECIFICATION

**HYES**

LCM

HT5711L

Page 11 of 22

### 3.2 Definition of optical characteristics

Measurement condition :

Transmissive and Transflective type

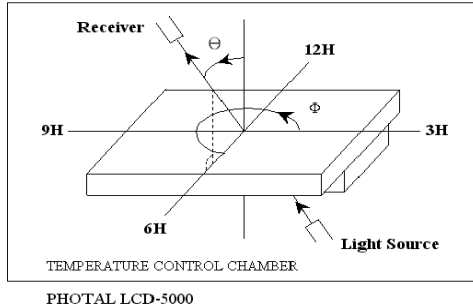

[Note 1] Definition of LCD Driving Vop and Waveform :

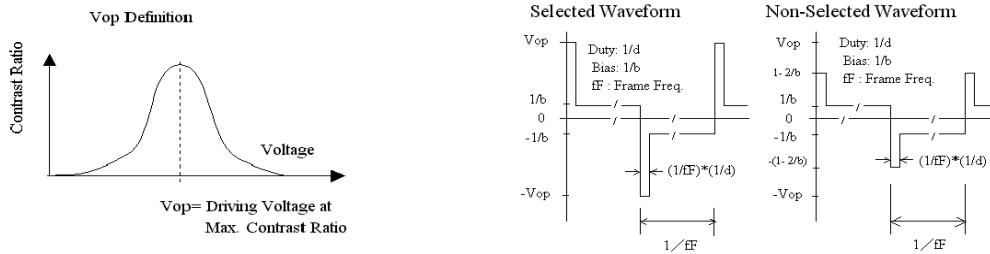

[Note 2] Definition of Response Time

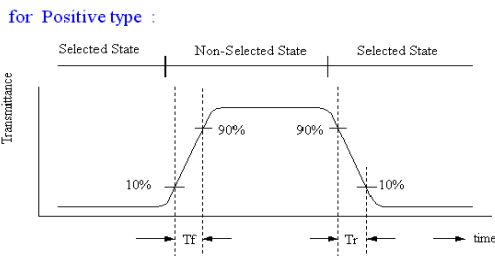

[Note 3] Definition of Viewing Angle :

[Note 4] Definition of Contrast Ratio :

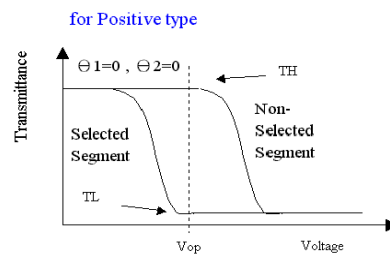
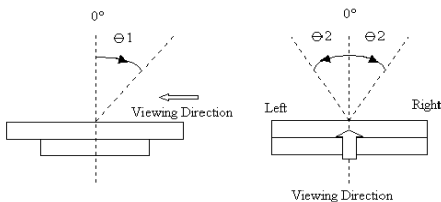

$$\text{Contrast Ratio} = \frac{TH}{TL}$$

Date : Jan. 07, 2009

TECHNICAL SPECIFICATION

**HYES**

LCM

HT5711L

Page 12 of 22

**[Note 5] Definition of measurement of Color Chromaticity and Brightness**

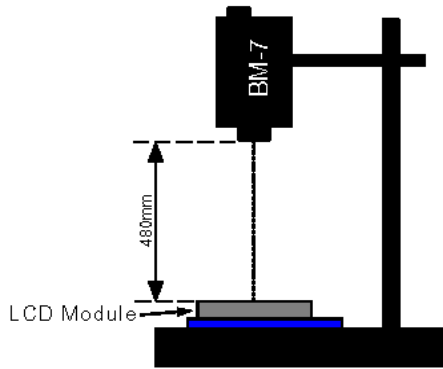

**[Note 6] Definition of Brightness Uniformity**

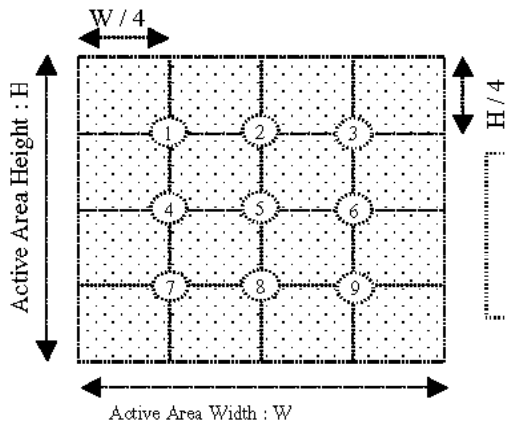

$$\text{Brightness Uniformity} = \frac{\text{Minimum Brightness of Point 1~9}}{\text{Maximum Brightness of Point 1~9}}$$

**[Note 7] Definition of Measurement of Reflectance**

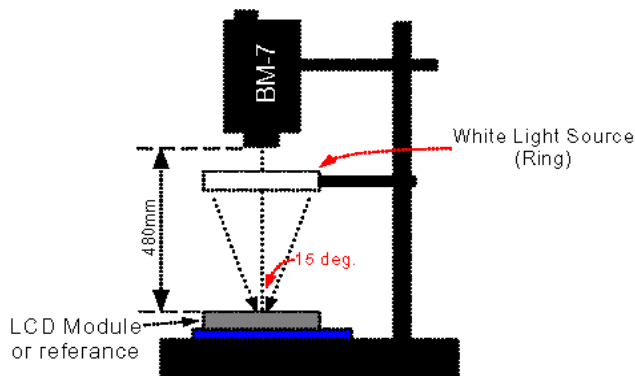

Date : Jan. 07, 2009

TECHNICAL SPECIFICATION

**HYES**

LCM

HT5711L

Page 13 of 22

**4. RELIABILITY :**

Item No	Items	Condition
1	High temperature operating	70 °C , 200 hours
2	Low temperature operating	-20 °C , 200 hours
3	High temperature storage	80 °C , 200 hours
4	Low temperature storage	-30 °C , 200 hours
5	High temperature & humidity storage	60°C, 90%RH, 100 hours
6	Thermal Shock storage	-30°C, 30min.<=> 80°C, 30min. 10 Cycles
7	Vibration test	10 => 55 =>10 => 55 => 10 Hz , within 1 minute Amplitude : 1.5mm. 15 minutes for each Direction ( X,Y,Z )
8	Drop test	Packed, 100CM free fall, 6 sides, 1 corner, 3edges
9	Life time	50,000 hours 25°C , 70%RH below , specification condition driving

- \* One single product test for only one item.
- \* Judgment after test : keep in room temperature for more than 2 hours.
  - Current consumption < 2 times of initial value
  - Contrast > 1/2 initial value
  - Function : work normally

Date : Jan. 07, 2009

TECHNICAL SPECIFICATION

**HYES**

LCM

HT5711L

Page 14 of 22

## 5. PRODUCT HANDLING AND APPLICATION

### PRECAUTION FOR HANDLING LCM

- The LCD module contains a C-MOS LSI. People who operate the LCM should wear ESD protection equipment to prevent ESD hurt on products.
- Do not input any signal before power is turned on.
- Do not take LCM from its packaging bag until it is assembled.
- Peel off the LCM protective film slowly since static electricity may be generated.
- Pay attention to the humidity of the work shop, 50~60%RH is satisfactory.
- Use a non-leak iron for soldering LCM.
- Do not touch the display surface or connection terminals area with bare hands. Smudges on the display surface reduce the insulation between terminals.
- Cautions for soldering to LCM:  
 Condition for soldering I/O terminals:  
 Temperature at iron tip :280°C±10°C.  
 Soldering time : 3~4sec./ terminals.  
 Type of solder : Eutectic solder(rosin flux filled).

### PRECAUTION IN USE OF LCD

- Do not contact or scratch the front surface and the contact pads of a LCD panel with hard materials such as metal or glass or with one's nail.
- To clean the surface , wipe it gently with soft cloth dampened by alcohol.
- Do not attempt to wiped off the contact pads.
- Keep LCD panels away from direct sunlight , also avoid them in high-temperature & high humidity environment for a long period.
- Do not drive LCD panels by DC voltage.
- Do not expose LCD panels to organic solvent.
- Liquid in LCD is hazardous substance. In case a contact with liquid crystal material is occurred, be sure to immediately wash such material away by soap and water.
- The polarizer is easily damaged and should be handle with special care. Don't press or rub it with hard objects.

### PRECAUTION FOR STORING LCM

- To avoid degradation of the device , do not store the module under the conditions of direct sunlight , high temperature or high humidity . Keep the module in bags designed to prevent static electricity charging under low temperature / normal humidity conditions(avoid high temperature / high humidity and low temperature below 0°C)

### USING ON MEDICAL CARE , SAFETY OR HAZARDOUS APPLICATION OR SYSTEM

- For the application in medical care, safety and hazardous products or systems, an authorization from **HYES** is required. **HYES** will not responsible for any damage or loss which caused by the products without any authorization given by **HYES**.
- This product is not allowed to be designed and used for military application and/or purpose.
- The delivery of this product to the countries and/or regions where the embargoes are imposed by U.N. is prohibited.

Date : Jan. 07, 2009		TECHNICAL SPECIFICATION	
	LCM	HT5711L	Page 15 of 22

## 6. DATE CODE OF PRODUCTS

- Date code will be shown on each product :

- **Y MM DD - XXX**

Year Month Day - Production lots

- Example: 2 1 2 2 3 - 0 0 3 ==> Year 2002, Dec.,23rd , Batch no.03

Date : Jan. 07, 2009

TECHNICAL SPECIFICATION

**HYES**

LCM

HT5711L

Page 16 of 22



## 7. PACKING

Instruction of lot number:

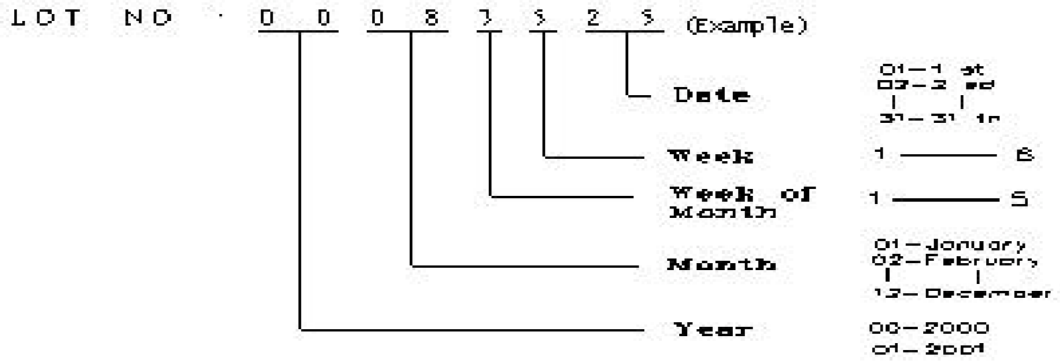

Label of carton:

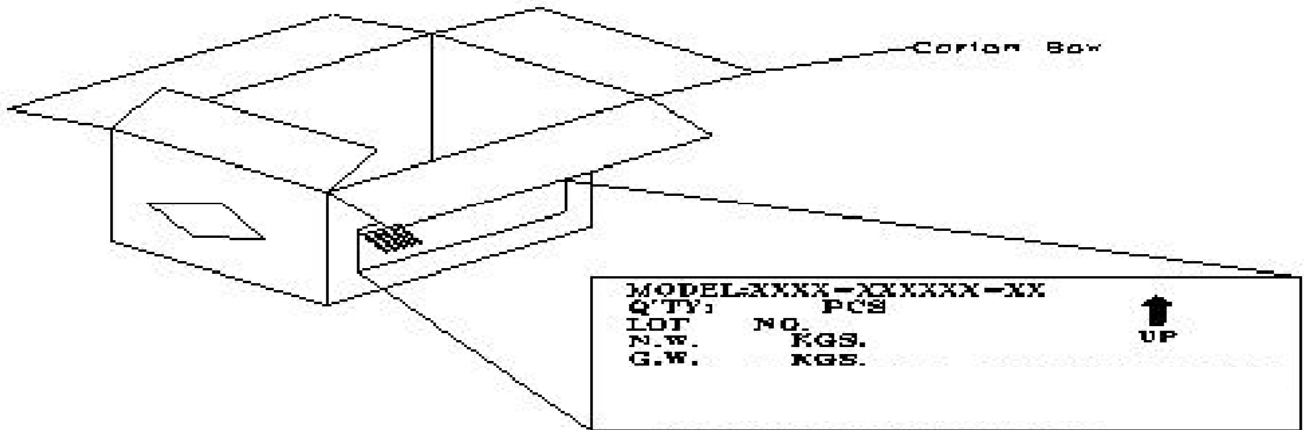

Packing tray must be stacked with alternated direction to each others.  
 To tacks packing trays in same direction will cause product damaged.

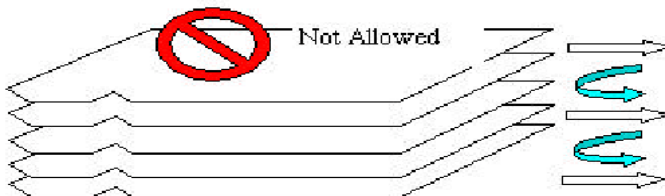
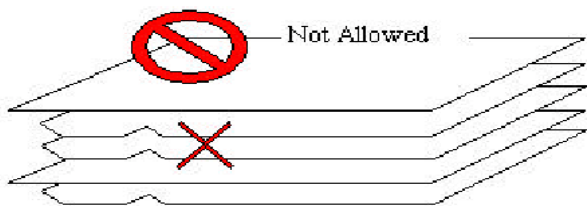

Date : Jan. 07, 2009

TECHNICAL SPECIFICATION

**HYES**

LCM

HT5711L

Page 17 of 22

**NOTE:**

- (1) Be warned, the direction of the tray has to turn it by 180 degree before stack it up. Otherwise, it will be packager's responsibility!!
- (2) Safe Stack : 5 cartons only

**TBD** pcs / Tray  
**TBD** Tray / Box  
**TBD** Box / Carton  
**TBD** pcs / Carton

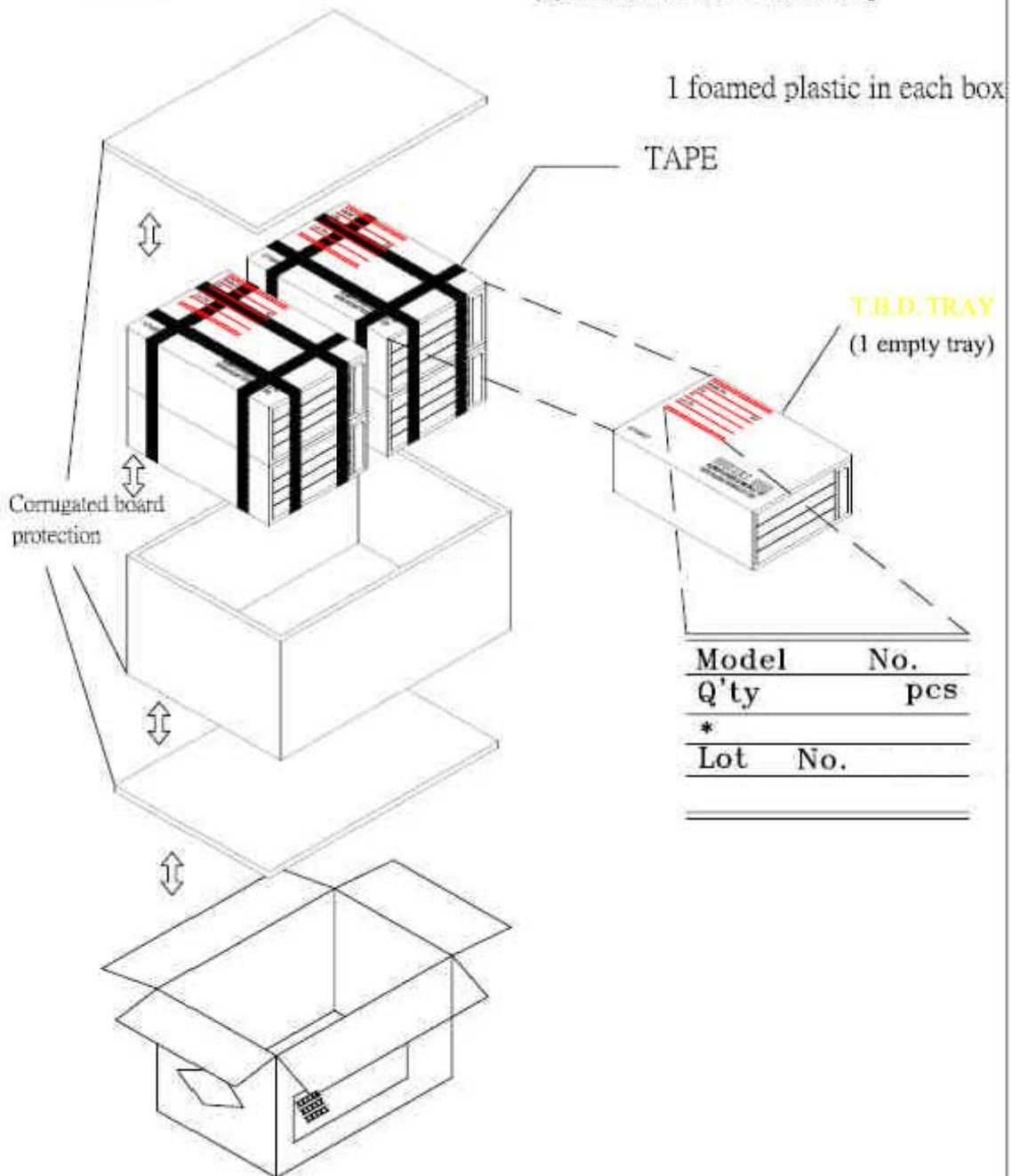

Date : Jan. 07, 2009

TECHNICAL SPECIFICATION

**HYES**

LCM

HT5711L

Page 18 of 22

## 8. INSPECTION STANDARD

### 8.1. QUALITY :

THE QUALITY OF GOODS SUPPLIED TO PURCHASER SHALL COME UP TO THE FOLLOWING STANDARD.

#### 8.1.1. THE METHOD OF PRESERVING GOODS

AFTER DELIVERY OF GOODS FROM **HYES** TO PURCHASER. PURCHASER SHALL CONTROL THE LCM AT -10 °C ~ 40 °C ,AND IT MIGHT BE DESIRABLE TO KEEP AT THE NORMAL ROOM TEMPERATURE AND HUMIDITY UNTIL INCOMING INSPECTION OR THROWING INTO PROCESS LINE.

#### 8.1.2. INCOMING INSPECTION

##### (A) THE METHOD OF INSPECTION

IF PURCHASER MAKE AN INCOMING INSPECTION , A SAMPLING PLAN SHALL BE APPLIED ON THE CONDITION THAT QUALITY OF ONE DELIVERY SHALL BE REGARDED AS ONE LOT.

##### (B) THE STANDARD OF QUALITY

ISO-2859-1 ( or MIL-STD-105D ), LEVEL II SINGLE PLAN.

CLASS	AQL(%)
CRITICAL	0.4 %
MAJOR	0.65 %
MINOR	1.5 %
TOTAL	1.5 %

EVERY ITEM SHALL BE INSPECTED ACCORDING TO THE CLASS.

##### (C) MEASURE

IF AS THE RESULT OF ABOVE RECEIVING INSPECTION , A LOT OUT IS DISCOVERED.

PURCHASER SHALL BE INFORM SELLER OF IT WITHIN SEVEN DAYS. BUT FIRST SHIPMENT WITHIN FOURTEEN DAYS.

#### 8.1.3. WARRANTY POLICY

**HYES** WILL PROVIDE ONE-YEAR WARRANTY FOR THE PRODUCTS ONLY IF UNDER SPECIFICATION OPERATING CONDITIONS. **HYES** WILL REPLACE NEW PRODUCTS FOR THESE DEFECT PRODUCTS WHICH UNDER WARRANTY PERIOD AND BELONG TO THE RESPONSIBILITY OF **HYES**.

## 8.2. CHECKING CONDITION

**8.2.1.** CHECKING DIRECTION SHALL BE IN THE 45 DEGREE AREA TO FACE THE SAMPLE.

**8.2.2.** CHECKER SHALL SEE OVER 30 cm. WITH BARE EYES FAR FROM SAMPLE AND USING 2 PCS. OF 20W FLUORESCENT LAMP.

Date : Jan. 07, 2009

TECHNICAL SPECIFICATION

**HYES**

LCM

HT5711L

Page 19 of 22

**8.3. INSPECTION PLAN :**

CLASS	ITEM	JUDGEMENT	CLASS
PACKING & INDICATE	1. OUTSIDE AND INSIDE PACKAGE	"MODEL NO.", "LOT NO." AND "QUANTITY" SHOULD INDICATE ON THE PACKAGE.	Minor
	2. MODEL MIXED AND QUANTITY	OTHER MODEL MIXED.....REJECTED QUANTITY SHORT OR OVER.....REJECTED	Critical
	3. PRODUCT INDICATION	"MODEL NO." SHOULD INDICATE ON THE PRODUCT	Major
ASSEMBLY	4. DIMENSION, LCD GLASS SCRATCH AND SCRIBE DEFECT.	ACCORDING TO SPECIFICATION OR DRAWING.	Major
APPEARANCE	5. VIEWING AREA	POLARIZER EDGE OR LCD'S SEALING LINE IS VISABLE IN THE VIEWING AREA .....REJECTED	Minor
	6. BLEMISH - BLACK SPOT - WHITE SPOT IN THE LCD AND LCD GLASS CRACKS	ACCORDING TO STANDARD OF VISUAL INSPECTION ( INSIDE VIEWING AREA )	Minor
	7. BLEMISH - BLACK SPOT WHITE SPOT AND SCRATCH ON THE POLARIZER	ACCORDING TO STANDARD OF VISUAL INSPECTION ( INSIDE VIEWING AREA )	Minor
	8. BUBBLE IN POLARIZER	ACCORDING TO STANDARD OF VISUAL INSPECTION ( INSIDE VIEWING AREA )	Minor
	9. LCD'S RAINBOW COLOR	STRONG DEVIATION COLOR ( OR NEWTON RING) OF LCD.....REJECTED. OR ACCORDING TO LIMITED SAMPLE ( IF NEEDED, AND INSIDE VIEWING AREA )	Minor
ELECTRICAL	10. ELECTRICAL AND OPTICAL CHARACTERISTICS ( CONTRAST - VOP - CHROMATICITY ... ETC )	ACCORDING TO SPECIFICATION OR DRAWING . ( INSIDE VIEWING AREA )	Critical
	11. MISSING PATTERN	MISSING DOT - LINE - CHARACTER .....REJECTED	Critical
	12. SHORT CIRCUIT - WRONG PATTERN DISPLAY	NON DISPLAY - WRONG PATTERN DISPLAY - CURRENT CONSUMPTION OUT OF SPECIFICATION..... REJECTED	Critical
	13. PIN HOLE - PATTERN DEFORMITY	ACCORDING TO STANDARD OF VISUAL INSPECTION	Minor

Date : Jan. 07, 2009

TECHNICAL SPECIFICATION

HYES

LCM

HT5711L

Page 20 of 22

**8.4. STANDARD OF VISUAL INSPECTION**

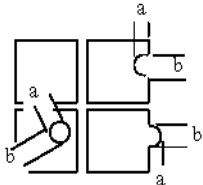
NO.	CLASS	ITEM	JUDGEMENT																									
8.4.1	MINOR	· BLEMISH · BLACK SPOT · WHITE SPOT IN THE LCD.  · BLEMISH · BLACK SPOT · WHITE SPOT AND SCRATCH ON THE POLARIZER	(A) ROUND TYPE: <span style="float:right">unit : mm.</span> <table border="1"> <thead> <tr> <th>DIAMETER (mm.)</th> <th>ACCEPTABLE Q'TY</th> </tr> </thead> <tbody> <tr> <td><math>\Phi \leq 0.1</math></td> <td>DISREGARD</td> </tr> <tr> <td><math>0.1 &lt; \Phi \leq 0.2</math></td> <td>2</td> </tr> <tr> <td><math>0.2 &lt; \Phi \leq 0.25</math></td> <td>1</td> </tr> <tr> <td><math>0.25 &lt; \Phi</math></td> <td>0</td> </tr> </tbody> </table> NOTE: $\Phi = (\text{LENGTH} + \text{WIDTH}) / 2$ (B) LINER TYPE: <span style="float:right">unit : mm.</span> <table border="1"> <thead> <tr> <th>LENGTH</th> <th>WIDTH</th> <th>ACCEPTABLE Q'TY</th> </tr> </thead> <tbody> <tr> <td>-----</td> <td><math>W \leq 0.03</math></td> <td>DISREGARD</td> </tr> <tr> <td><math>L \leq 5.0</math></td> <td><math>0.03 &lt; W \leq 0.05</math></td> <td>3</td> </tr> <tr> <td><math>L \leq 5.0</math></td> <td><math>0.05 &lt; W \leq 0.07</math></td> <td>1</td> </tr> <tr> <td>-----</td> <td><math>0.07 &lt; W</math></td> <td>FOLLOW ROUND TYPE</td> </tr> </tbody> </table>	DIAMETER (mm.)	ACCEPTABLE Q'TY	$\Phi \leq 0.1$	DISREGARD	$0.1 < \Phi \leq 0.2$	2	$0.2 < \Phi \leq 0.25$	1	$0.25 < \Phi$	0	LENGTH	WIDTH	ACCEPTABLE Q'TY	-----	$W \leq 0.03$	DISREGARD	$L \leq 5.0$	$0.03 < W \leq 0.05$	3	$L \leq 5.0$	$0.05 < W \leq 0.07$	1	-----	$0.07 < W$	FOLLOW ROUND TYPE
DIAMETER (mm.)	ACCEPTABLE Q'TY																											
$\Phi \leq 0.1$	DISREGARD																											
$0.1 < \Phi \leq 0.2$	2																											
$0.2 < \Phi \leq 0.25$	1																											
$0.25 < \Phi$	0																											
LENGTH	WIDTH	ACCEPTABLE Q'TY																										
-----	$W \leq 0.03$	DISREGARD																										
$L \leq 5.0$	$0.03 < W \leq 0.05$	3																										
$L \leq 5.0$	$0.05 < W \leq 0.07$	1																										
-----	$0.07 < W$	FOLLOW ROUND TYPE																										
8.4.2	MINOR	BUBBLE IN POLARIZER	<span style="float:right">unit : mm.</span> <table border="1"> <thead> <tr> <th>DIAMETER</th> <th>ACCEPTABLE Q'TY</th> </tr> </thead> <tbody> <tr> <td><math>\Phi \leq 0.15</math></td> <td>DISREGARD</td> </tr> <tr> <td><math>0.15 &lt; \Phi \leq 0.5</math></td> <td>2</td> </tr> <tr> <td><math>0.5 &lt; \Phi</math></td> <td>0</td> </tr> </tbody> </table>	DIAMETER	ACCEPTABLE Q'TY	$\Phi \leq 0.15$	DISREGARD	$0.15 < \Phi \leq 0.5$	2	$0.5 < \Phi$	0																	
DIAMETER	ACCEPTABLE Q'TY																											
$\Phi \leq 0.15$	DISREGARD																											
$0.15 < \Phi \leq 0.5$	2																											
$0.5 < \Phi$	0																											
8.4.3	MINOR	PIN HOLE · PATTERN DEFORMITY	<span style="float:right">unit : mm.</span>  <table border="1"> <thead> <tr> <th>DIAMETER</th> <th>ACC. Q'TY</th> </tr> </thead> <tbody> <tr> <td><math>\Phi \leq 0.1</math></td> <td>DISREGARD</td> </tr> <tr> <td><math>0.1 &lt; \Phi \leq 0.25</math></td> <td>3</td> </tr> <tr> <td><math>0.25 &lt; \Phi</math></td> <td>0</td> </tr> </tbody> </table> $\Phi = (a+b)/2$	DIAMETER	ACC. Q'TY	$\Phi \leq 0.1$	DISREGARD	$0.1 < \Phi \leq 0.25$	3	$0.25 < \Phi$	0																	
DIAMETER	ACC. Q'TY																											
$\Phi \leq 0.1$	DISREGARD																											
$0.1 < \Phi \leq 0.25$	3																											
$0.25 < \Phi$	0																											

Date : Jan. 07, 2009

TECHNICAL SPECIFICATION

**HYES**

LCM

HT5711L

Page 21 of 22

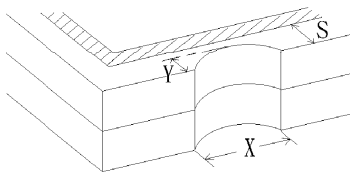
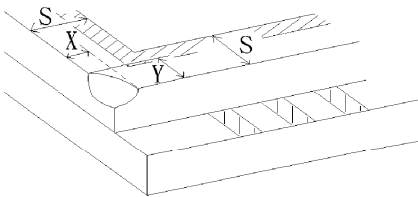
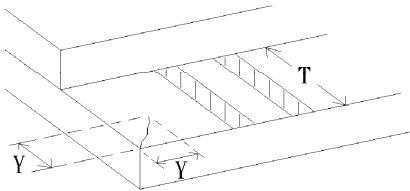
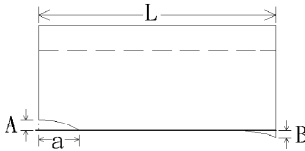
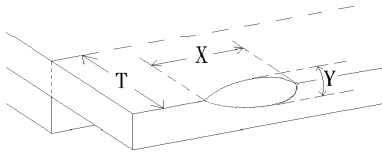
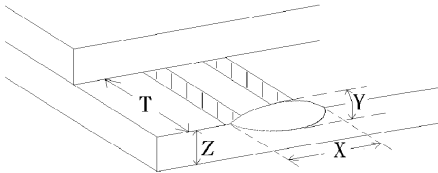
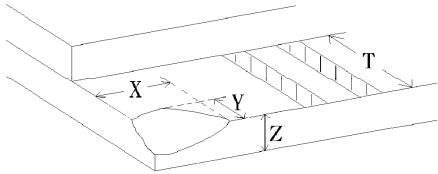
NO.	CLASS	ITEM	JUDGEMENT
8.4.4	MINOR	CHIPPING	 $Y > S$ REJ.
8.4.5	MINOR	CHIPPING	 $X \text{ or } Y > S$ REJ.
8.4.6	MAJOR	GLASS CRACK	 $Y > (1/2) T$ REJ.
8.4.7	MAJOR	SCRIBE DEFECT	 <ol style="list-style-type: none"> <li><math>a &gt; L/3</math>, <math>A &gt; 1.5\text{mm}</math>. REJ.</li> <li>B : ACCORDING TO DIMENSION</li> </ol>
8.4.8	MINOR	CHIPPING ( ON THE TERMINAL AREA )	 $\Phi = (x+y)/2 > 2.5 \text{ mm}$ REJ.
8.4.9	MINOR	CHIPPING ( ON THE TERMINAL SURFACE )	 $Y > (1/3) T$ REJ.
8.4.10	MINOR	CHIPPING	 $Y > T$ REJ.

Date : Jan. 07, 2009

TECHNICAL SPECIFICATION

**HYES**

LCM

HT5711L

Page 22 of 22