



Enhanced A/D Flash MCU with LCD & EEPROM

HT67F4892

Revision: V1.00 Date: November 24, 2016

www.holtek.com

Table of Contents

Features	6
CPU Features	6
Peripheral Features.....	7
General Description	8
Block Diagram	8
Pin Assignment	9
Pin Description	11
Absolute Maximum Ratings	14
D.C. Characteristics	15
A.C. Characteristics	17
A/D Converter Electrical Characteristics	18
Reference Voltage Characteristics	18
LVD/LVR Electrical Characteristics	19
Power-on Reset Characteristics	19
System Architecture	20
Clocking and Pipelining.....	20
Program Counter.....	21
Stack	21
Arithmetic and Logic Unit – ALU	22
Flash Program Memory	23
Structure.....	23
Special Vectors	23
Look-up Table	23
Table Program Example.....	24
In Circuit Programming – ICP	25
On-Chip Debug Support – OCDS	26
RAM Data Memory	27
Structure.....	27
Data Memory Addressing.....	28
General Purpose Data Memory	28
Special Purpose Data Memory	28
Special Function Register Description	30
Indirect Addressing Registers – IAR0, IAR1, IAR2	30
Memory Pointers – MP0, MP1L, MP1H, MP2L, MP2H.....	30
Accumulator – ACC	31
Program Counter Low Register – PCL	32
Look-up Table Registers – TBLP, TBHP, TBLH	32
Status Register – STATUS	32

EEPROM Data Memory	34
EEPROM Data Memory Structure	34
EEPROM Registers	34
Reading Data from the EEPROM	36
Writing Data to the EEPROM.....	36
Write Protection.....	36
EEPROM Interrupt	36
Programming Considerations.....	37
Oscillators	38
Oscillator Overview	38
System Clock Configurations	38
External High Speed Crystal Oscillator – HXT	39
Internal RC Oscillator – HIRC	39
External 32.768 kHz Crystal Oscillator – LXT	40
Internal 32kHz Oscillator – LIRC.....	41
Operating Modes and System Clocks	42
System Clocks	42
System Operation Modes.....	43
Control Registers	44
Operating Mode Switching	46
Standby Current Considerations	50
Wake-up	50
Watchdog Timer	51
Watchdog Timer Clock Source.....	51
Watchdog Timer Control Register	51
Watchdog Timer Operation	52
Reset and Initialisation	53
Reset Functions	53
Reset Initial Conditions	55
Input/Output Ports	59
Pull-high Resistors	59
Port A Wake-up	60
I/O Port Control Registers	60
Pin-shared Functions	61
I/O Pin Structures.....	61
Programming Considerations.....	61
Timer Modules – TM	62
Introduction	62
TM Operation	62
TM Clock Source.....	63
TM Interrupts.....	63
TM External Pins.....	63
TM Input/Output Pin Control Register	64
Programming Considerations.....	66

Compact Type TM – CTM	67
Compact Type TM Operation	67
Compact Type TM Register Description.....	67
Compact Type TM Operating Modes	71
Periodic Type TM – PTM	77
Periodic Type TM Operation	77
Periodic Type TM Register Description	78
Periodic Type TM Operating Modes	82
Analog to Digital Converter – ADC.....	91
A/D Converter Overview	91
A/D Converter Register Description	91
A/D Converter Operation	95
A/D Converter Reference Voltage.....	96
A/D Converter Input Signals.....	96
Conversion Rate and Timing Diagram	97
Summary of A/D Conversion Steps.....	98
Programming Considerations.....	99
A/D Conversion Function	99
A/D Conversion Programming Examples.....	100
Serial Interface Module – SIM	102
SPI Interface	102
I ² C Interface	111
LCD Display Memory.....	121
LCD Driver Output.....	121
LCD Control Register	122
LCD Waveform.....	126
LED Driver	130
LED Driver Operation.....	130
LED Driver Register	130
UART Interface.....	131
UART External Pin Interfacing	131
UART Data Transfer Scheme.....	131
UART Status and Control Registers.....	132
Baud Rate Generator.....	138
UART Setup and Control.....	139
UART Transmitter.....	140
UART Receiver	142
Managing Receiver Errors	143
UART Module Interrupt Structure.....	144
UART Power Down and Wake-up.....	146
Interrupts	147
Interrupt Registers.....	147
Interrupt Operation.....	153
External Interrupt.....	154

A/D Converter Interrupt.....	155
Multi-function Interrupts.....	155
Serial Interface Module Interrupt.....	155
UART Interrupt.....	155
Time Base Interrupts.....	156
EEPROM Interrupt.....	157
LVD Interrupt.....	157
Timer Module Interrupts.....	157
Interrupt Wake-up Function.....	158
Programming Considerations.....	158
Low Voltage Detector – LVD	159
LVD Register.....	159
LVD Operation.....	160
Configuration Options.....	161
Application Circuits.....	162
Instruction Set.....	163
Introduction.....	163
Instruction Timing.....	163
Moving and Transferring Data.....	163
Arithmetic Operations.....	163
Logical and Rotate Operation.....	164
Branches and Control Transfer.....	164
Bit Operations.....	164
Table Read Operations.....	164
Other Operations.....	164
Instruction Set Summary	165
Table Conventions.....	165
Extended Instruction Set.....	167
Instruction Definition.....	169
Extended Instruction Definition.....	178
Package Information	185
48-pin LQFP (7mm×7mm) Outline Dimensions.....	186
52-pin LQFP (14mm×14mm) Outline Dimensions.....	187

Features

CPU Features

- Operating Voltage
 - ♦ $f_{SYS}=4\text{MHz}$: 2.2V~5.5V
 - ♦ $f_{SYS}=8\text{MHz}$: 2.2V~5.5V
 - ♦ $f_{SYS}=12\text{MHz}$: 2.7V~5.5V
 - ♦ $f_{SYS}=16\text{MHz}$: 4.5V~5.5V
- Up to 0.25 μs instruction cycle with 16MHz system clock at $V_{DD}=5\text{V}$
- Power down and wake-up functions to reduce power consumption
- Four Oscillators:
 - ♦ High Speed Internal RC – HIRC
 - ♦ Internal 32kHz RC – LIRC
 - ♦ High Speed External Crystal – HXT
 - ♦ External 32.768kHz Crystal – LXT
- Multi-mode operation: NORMAL, SLOW, IDLE and SLEEP
- Fully integrated internal 8MHz oscillator requires no external components
- All instructions executed in 1~3 instruction cycles
- Table read instructions
- 115 powerful instructions
- 8-level subroutine nesting
- Bit manipulation instruction

Peripheral Features

- Flash Program Memory: $8K \times 16$
- RAM Data Memory: 384×8
- True EEPROM Memory: 64×8
- Watchdog Timer function
- Up to 50 bidirectional I/O lines
- 4 pin-shared external interrupts
- Multiple Timer Modules for time measure, input capture, compare match output, PWM output or single pulse output function
- Dual Time-Base functions for generation of fixed time interrupt signals
- 10-channel 12-bit resolution A/D converter
- LCD display:
 - ♦ $32SEG \times 4COM$ & $32SEG \times 8COM$ for 52-pin LQFP package type
 - ♦ $28SEG \times 4COM$ & $28SEG \times 8COM$ for 48-pin LQFP package type
 - ♦ 1/3 or 1/4 bias
- LED display: $8SEG \times 8COM$
- Serial Interface Module with SPI and I²C interfaces
- Full-duplex Universal Asynchronous Receiver and Transmitter Interface – UART
- Low Voltage Reset function – LVR
- Low Voltage Detect function – LVD
- Package type: 48/52-pin LQFP
- Flash program memory can be re-programmed up to 100,000 times
- Flash program memory data retention > 10 years
- True EEPROM data memory can be re-programmed up to 1,000,000 times
- True EEPROM data memory data retention > 10 years

General Description

The HT67F4892 is a Flash Memory A/D type 8-bit high performance RISC architecture microcontroller, designed especially for applications that interface directly to analog signals, such as those from sensors. Offering users the convenience of Flash Memory multi-programming features, this device also includes a wide range of functions and features. Other memory includes an area of RAM Data Memory as well as an area of true EEPROM memory for storage of non-volatile data such as serial numbers, calibration data etc.

Analog features include a multi-channel 12-bit A/D converter. Multiple and extremely flexible Timer Modules provide timing, pulse generation and PWM generation functions. Easy communication with the outside world is provided by including fully integrated SPI, I²C functions, popular interfaces which provide designers with a means of easy communication with external peripheral hardware. Protective features such as an internal Watchdog Timer, Low Voltage Reset and Low Voltage Detector coupled with excellent noise immunity and ESD protection ensure that reliable operation is maintained in hostile electrical environments.

A full choice of external, internal and high and low oscillators functions are provided including two fully integrated system oscillators which require no external components for their implementation. The ability to operate and switch dynamically between a range of operating modes using different clock sources gives users the ability to optimise microcontroller operation and minimise power consumption. The UART module is contained in the device. It can support the applications such as data communication networks between microcontrollers, low-cost data links between PCs and peripheral devices, portable and battery operated device communication, etc.

The inclusion of both LCD and LED driver functions allows for easy and cost effective solutions in applications that require interface to these display types. In addition, the inclusion of flexible I/O programming features, Time-Base functions along with many other features ensure that only a minimum of external components is required for application implementation, resulting in reduced component costs and reductions in circuit board areas.

Block Diagram

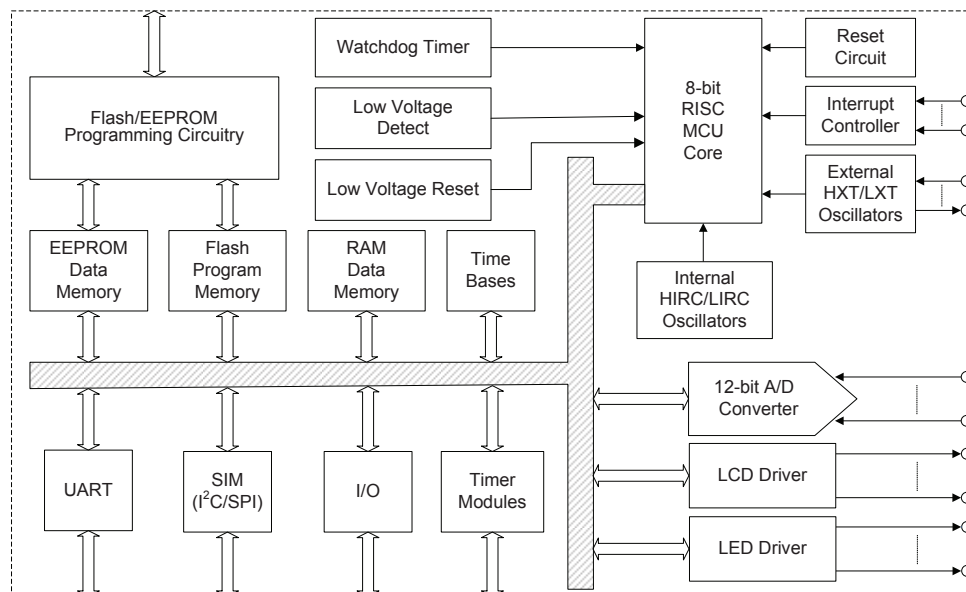

Pin Assignment

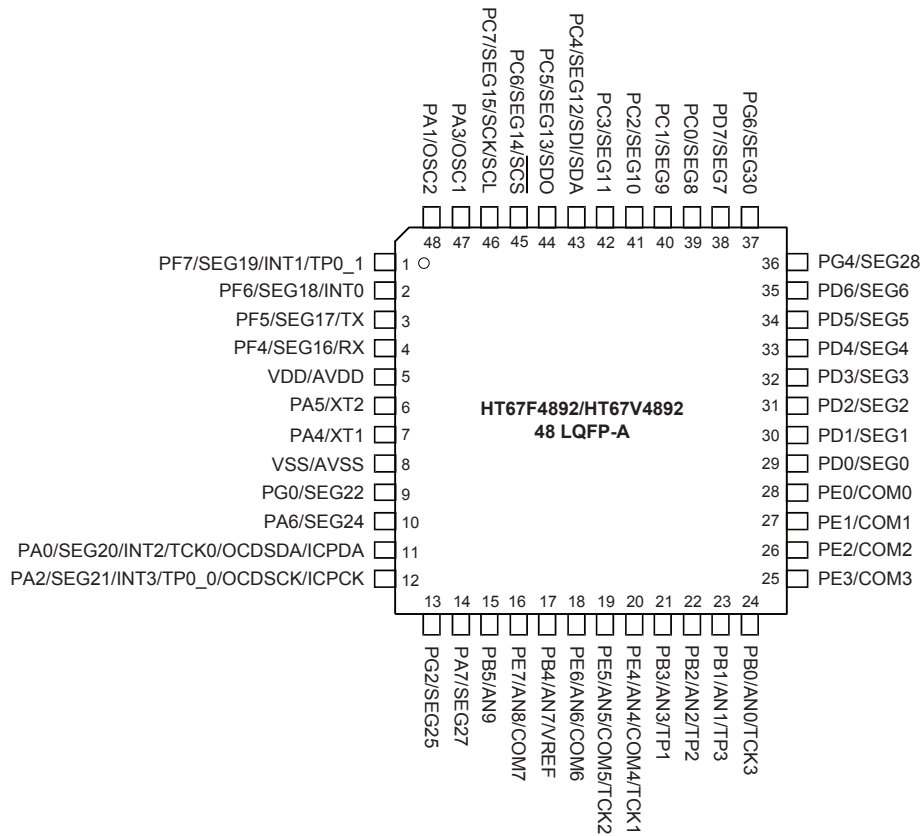

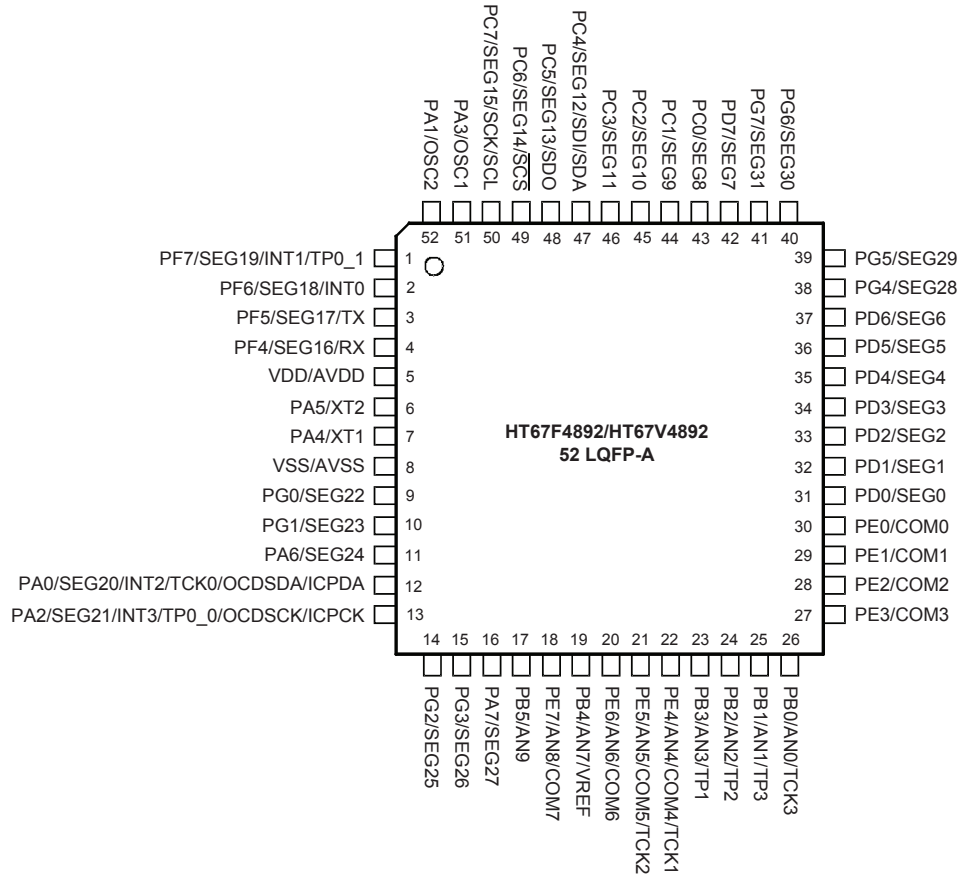

- Note: 1. If the pin-shared pin functions have multiple outputs simultaneously, its pin names at the right side of the "/" sign can be used for higher priority.
2. The OCSDA and OCDSCK pins are supplied as dedicated OCDS pins and as such only available for the HT67V4892 device which is the OCDS EV chip for the HT67F4892 device.

Pin Description

With the exception of the power pins and some relevant transformer control pins, all pins on the device can be referenced by its Port name, e.g. PA0, PA1 etc, which refer to the digital I/O function of the pins. However these Port pins are also shared with other function such as the Analog to Digital Converter, Timer Module pins etc. The function of each pin is listed in the following table, however the details behind how each pin is configured is contained in other sections of the datasheet. Note that where more than one package type exists the table will reflect the situation for the larger package type.

Pin Name	Function	OPT	I/T	O/T	Description
PA0/SEG20/INT2/ TCK0/OCDSDA/ ICPDA	PA0	PAWU PAPU	ST	CMOS	General purpose I/O. Register enabled pull-up and wake-up.
	SEG20	SEGCR2	—	AN	LCD segment output
	INT2	INTEG INTC2	ST	—	External interrupt 2
	TCK0	—	ST	—	TM0 clock input
	OCDSDA	—	ST	CMOS	OCDS address/data, for EV chip only
	ICPDA	—	ST	CMOS	ICP address/data
PA1/OSC2	PA1	PAWU PAPU	ST	CMOS	General purpose I/O. Register enabled pull-up and wake-up.
	OSC2	CO	—	HXT	HXT output pin
PA2/SEG21/INT3/ TP0_0/OCDSCK/ ICPCK	PA2	PAWU PAPU	ST	CMOS	General purpose I/O. Register enabled pull-up and wake-up.
	SEG21	SEGCR2	—	AN	LCD segment output
	INT3	INTEG INTC2	ST	—	External interrupt 3
	TP0_0	TMPC	ST	CMOS	TM0 I/O
	OCDSCK	—	ST	—	OCDS clock, for EV chip only
PA3/OSC1	PA3	PAWU PAPU	ST	CMOS	General purpose I/O. Register enabled pull-up and wake-up.
	OSC1	CO	HXT	—	HXT input pin
PA4/XT1	PA4	PAWU PAPU	ST	CMOS	General purpose I/O. Register enabled pull-up and wake-up.
	XT1	FSUBC	LXT	—	LXT input pin
PA5/XT2	PA5	PAWU PAPU	ST	CMOS	General purpose I/O. Register enabled pull-up and wake-up.
	XT2	FSUBC	—	LXT	LXT output pin
PA6/SEG24	PA6	PAWU PAPU	ST	CMOS	General purpose I/O. Register enabled pull-up and wake-up.
	SEG24	SEGCR3	—	AN	LCD segment output
PA7/SEG27	PA7	PAWU PAPU	ST	CMOS	General purpose I/O. Register enabled pull-up and wake-up.
	SEG27	SEGCR3	—	AN	LCD segment output
PB0/AN0/TCK3	PB0	PBPU	ST	CMOS	General purpose I/O.Register enabled pull-high.
	AN0	ACERL	AN	—	ADC input channel 0
	TCK3	—	ST	—	TM3 clock input
PB1/AN1/TP3	PB1	PBPU	ST	CMOS	General purpose I/O.Register enabled pull-high.
	AN1	ACERL	AN	—	ADC input channel 1
	TP3	TMPC	ST	CMOS	TM3 I/O

Pin Name	Function	OPT	I/T	O/T	Description
PB2/AN2/TP2	PB2	PBPU	ST	CMOS	General purpose I/O.Register enabled pull-high.
	AN2	ACERL	AN	—	ADC input channel 2
	TP2	TMPC	ST	CMOS	TM2 I/O
PB3/AN3/TP1	PB3	PBPU	ST	CMOS	General purpose I/O.Register enabled pull-high.
	AN3	ACERL	AN	—	ADC input channel 3
	TP1	TMPC	ST	CMOS	TM1 I/O
PB4/AN7/VREF	PB4	PBPU	ST	CMOS	General purpose I/O.Register enabled pull-high.
	AN7	ACERL	AN	—	ADC input channel 7
	VREF	ADCR1	AN	—	ADC reference voltage input pin
PB5/AN9	PB5	PBPU	ST	CMOS	General purpose I/O.Register enabled pull-high.
	AN9	ACERH	AN	—	ADC input channel 9
PC0/SEG8	PC0	PCPU	ST	CMOS	General purpose I/O.Register enabled pull-high.
	SEG8	SEGCR1	—	AN	LCD segment output
PC1/SEG9	PC1	PCPU	ST	CMOS	General purpose I/O.Register enabled pull-high.
	SEG9	SEGCR1	—	AN	LCD segment output
PC2/SEG10	PC2	PCPU	ST	CMOS	General purpose I/O.Register enabled pull-high.
	SEG10	SEGCR1	—	AN	LCD segment output
PC3/SEG11	PC3	PCPU	ST	CMOS	General purpose I/O.Register enabled pull-high.
	SEG11	SEGCR1	—	AN	LCD segment output
PC4/SEG12/SDI/SDA	PC4	PCPU	ST	CMOS	General purpose I/O.Register enabled pull-high.
	SEG12	SEGCR1	—	AN	LCD segment output
	SDI	SIMC0	ST	—	SPI serial data input
	SDA	SIMC0	ST	NMOS	I ² C data line
PC5/SEG13/SDO	PC5	PCPU	ST	CMOS	General purpose I/O.Register enabled pull-high.
	SEG13	SEGCR1	—	AN	LCD segment output
	SDO	SIMC0	—	CMOS	SPI serial data output
PC6/SEG14/ \overline{SCS}	PC6	PCPU	ST	CMOS	General purpose I/O.Register enabled pull-high.
	SEG14	SEGCR1	—	AN	LCD segment output
	\overline{SCS}	SIMC0 SIMC2	ST	CMOS	SPI slave select pin
PC7/SEG15/SCK/ SCL	PC7	PCPU	ST	CMOS	General purpose I/O.Register enabled pull-high.
	SEG15	SEGCR1	—	AN	LCD segment output
	SCK	SIMC0	ST	CMOS	SPI serial clock
	SCL	SIMC0	ST	NMOS	I ² C clock line
PD0/SEG0	PD0	PDPU	ST	CMOS	General purpose I/O.Register enabled pull-high.
	SEG0	SEGCR0	—	AN	LCD segment output
PD1/SEG1	PD1	PDPU	ST	CMOS	General purpose I/O.Register enabled pull-high.
	SEG1	SEGCR0	—	AN	LCD segment output
PD2/SEG2	PD2	PDPU	ST	CMOS	General purpose I/O.Register enabled pull-high.
	SEG2	SEGCR0	—	AN	LCD segment output
PD3/SEG3	PD3	PDPU	ST	CMOS	General purpose I/O.Register enabled pull-high.
	SEG3	SEGCR0	—	AN	LCD segment output
PD4/SEG4	PD4	PDPU	ST	CMOS	General purpose I/O.Register enabled pull-high.
	SEG4	SEGCR0	—	AN	LCD segment output
PD5/SEG5	PD5	PDPU	ST	CMOS	General purpose I/O.Register enabled pull-high.
	SEG5	SEGCR0	—	AN	LCD segment output
PD6/SEG6	PD6	PDPU	ST	CMOS	General purpose I/O.Register enabled pull-high.
	SEG6	SEGCR0	—	AN	LCD segment output

Pin Name	Function	OPT	I/T	O/T	Description
PD7/SEG7	PD7	PDPU	ST	CMOS	General purpose I/O.Register enabled pull-high.
	SEG7	SEGCR0	—	AN	LCD segment output
PE0/COM0	PE0	PEPU	ST	CMOS	General purpose I/O.Register enabled pull-high.
	COM0	LCDC0	—	AN	LCD commom output
PE1/COM1	PE1	PEPU	ST	CMOS	General purpose I/O.Register enabled pull-high.
	COM1	LCDC0	—	AN	LCD commom output
PE2/COM2	PE2	PEPU	ST	CMOS	General purpose I/O.Register enabled pull-high.
	COM2	LCDC0	—	AN	LCD commom output
PE3/COM3	PE3	PEPU	ST	CMOS	General purpose I/O.Register enabled pull-high.
	COM3	LCDC0	—	AN	LCD commom output
PE4/AN4/COM4/ TCK1	PE4	PEPU	ST	CMOS	General purpose I/O.Register enabled pull-high.
	AN4	ACERL	AN	—	ADC input channel 4
	COM4	LCDC0	—	AN	LCD commom output
	TCK1	—	ST	—	TM1 clock input
PE5/AN5/COM5/ TCK2	PE5	PEPU	ST	CMOS	General purpose I/O. Register enabled pull-high.
	AN5	ACERL	AN	—	ADC input channel 5
	COM5	LCDC0	—	AN	LCD commom output
	TCK2	—	ST	—	TM2 clock input
PE6/AN6/COM6	PE6	PEPU	ST	CMOS	General purpose I/O.Register enabled pull-high.
	AN6	ACERL	AN	—	ADC input channel 6
	COM6	LCDC0	—	AN	LCD commom output
PE7/AN8/COM7	PE7	PEPU	ST	CMOS	General purpose I/O.Register enabled pull-high.
	AN8	ACERL	AN	—	ADC input channel 8
	COM7	LCDC0	—	AN	LCD commom output
PF4/SEG16/RX	PF4	PFPU	ST	CMOS	General purpose I/O.Register enabled pull-high.
	SEG16	SEGCR2	—	AN	LCD segment output
	RX	UCR1	ST	—	UART RX serial data input pin
PF5/SEG17/TX	PF5	PFPU	ST	CMOS	General purpose I/O.Register enabled pull-high.
	SEG17	SEGCR2	—	AN	LCD segment output
	TX	UCR1	—	CMOS	UART TX serial data output pin
PF6/SEG18/INT0	PF6	PFPU	ST	CMOS	General purpose I/O.Register enabled pull-high.
	SEG18	SEGCR2	—	AN	LCD segment output
	INT0	INTEG INTC0	ST	—	External interrupt 0
PF7/SEG19/INT1/ TP0_1	PF7	PFPU	ST	CMOS	General purpose I/O.Register enabled pull-high.
	SEG19	SEGCR2	—	AN	LCD segment output
	INT1	INTEG INTC0	ST	—	External interrupt 1
	TP0_1	TMPC	ST	CMOS	TM0 I/O
PG0/SEG22	PG0	PGPU	ST	CMOS	General purpose I/O.Register enabled pull-high.
	SEG22	SEGCR2	—	AN	LCD segment output
PG1/SEG23	PG1	PGPU	ST	CMOS	General purpose I/O.Register enabled pull-high.
	SEG23	SEGCR2	—	AN	LCD segment output
PG2/SEG25	PG2	PGPU	ST	CMOS	General purpose I/O.Register enabled pull-high.
	SEG25	SEGCR3	—	AN	LCD segment output
PG3/SEG26	PG3	PGPU	ST	CMOS	General purpose I/O.Register enabled pull-high.
	SEG26	SEGCR3	—	AN	LCD segment output

Pin Name	Function	OPT	I/T	O/T	Description
PG4/SEG28	PG4	PGPU	ST	CMOS	General purpose I/O.Register enabled pull-high.
	SEG28	SEGCR3	—	AN	LCD segment output
PG5/SEG29	PG5	PGPU	ST	CMOS	General purpose I/O.Register enabled pull-high.
	SEG29	SEGCR3	—	AN	LCD segment output
PG6/SEG30	PG6	PGPU	ST	CMOS	General purpose I/O.Register enabled pull-high.
	SEG30	SEGCR3	—	AN	LCD segment output
PG7/SEG31	PG7	PGPU	ST	CMOS	General purpose I/O.Register enabled pull-high.
	SEG31	SEGCR3	—	AN	LCD segment output
VDD/AVDD	VDD	—	PWR	—	Digital positive power supply
	AVDD	—	PWR	—	Analog positive power supply
VSS/AVSS	VSS	—	PWR	—	Digital negative power supply
	AVSS	—	PWR	—	Analog negative power supply

Legend: I/T: Input type; O/T: Output type;
 OPT: Optional by configuration options (CO) or register option;
 PWR: Power;
 ST: Schmitt Trigger input; AN: Analog signal
 CMOS: CMOS output; NMOS: NMOS output;
 HXT: High frequency crystal oscillator; LXT: Low frequency crystal oscillator

Absolute Maximum Ratings

Supply Voltage	$V_{SS}-0.3V$ to $V_{SS}+6.0V$
Input Voltage	$V_{SS}-0.3V$ to $V_{DD}+0.3V$
Storage Temperature.....	-50°C to 125°C
Operating Temperature.....	-40°C to 85°C
I _{OL} Total	80mA
I _{OH} Total	-80mA
Total Power Dissipation	500mW

Note: These are stress ratings only. Stresses exceeding the range specified under "Absolute Maximum Ratings" may cause substantial damage to the device. Functional operation of this device at other conditions beyond those listed in the specification is not implied and prolonged exposure to extreme conditions may affect device reliability.

D.C. Characteristics

Ta=25°C

Symbol	Parameter	Test Conditions		Min.	Typ.	Max.	Unit
		V _{DD}	Conditions				
V _{DD}	Operating Voltage (HXT)	—	f _{SYS} =f _{HXT} =4MHz	2.2	—	5.5	V
			f _{SYS} =f _{HXT} =8MHz	2.2	—	5.5	
			f _{SYS} =f _{HXT} =12MHz	2.7	—	5.5	
			f _{SYS} =f _{HXT} =16MHz	4.5	—	5.5	
	Operating Voltage (HIRC)	—	f _{SYS} =f _{HIRC} =8MHz	2.2	—	5.5	
Operating Voltage (LXT)	—	f _{SYS} =f _{LXT} =32.768kHz	2.2	—	5.5		
Operating Voltage (LIRC)	—	f _{SYS} =f _{LIRC} =32kHz	2.2	—	5.5		
I _{DD}	Operating Current, NORMAL Mode	3V	No load, f _H =8MHz, ADC off, WDT enable f _{SYS} =f _H , f _{SUB} =f _{LXT} or f _{LIRC}	—	1.6	2.4	mA
		5V		—	3.3	5.0	
	Operating Current (HXT)	3V	No load, f _{SYS} =f _H /2, ADC off, WDT enable	—	0.9	1.5	mA
			5V	—	2.5	3.75	
		3V	No load, f _{SYS} =f _H /4, ADC off, WDT enable	—	0.7	1.0	
			5V	—	2.0	3.0	
		3V	No load, f _{SYS} =f _H /8, ADC off, WDT enable	—	0.6	0.9	
			5V	—	1.6	2.4	
		3V	No load, f _{SYS} =f _H /16, ADC off, WDT enable	—	0.5	0.75	
			5V	—	1.5	2.25	
		3V	No load, f _{SYS} =f _H /32, ADC off, WDT enable	—	0.49	0.74	
			5V	—	1.45	2.18	
	3V	No load, f _{SYS} =f _H /64, ADC off, WDT enable	—	0.47	0.71		
		5V	—	1.4	2.1		
	Operating Current, SLOW Mode (LXT, LIRC)	3V	No load, f _{SYS} =f _{SUB} =f _{LXT} =32768Hz, ADC off, WDT enable, LXTLP=0, LVR enable	—	45	75	μA
				5V	—	90	
		3V	No load, f _{SYS} =f _{SUB} =f _{LXT} =32768Hz, ADC off, WDT enable, LXTLP=1, LVR enable	—	40	70	μA
				5V	—	85	
		3V	No load, f _{SYS} =f _{SUB} =f _{LIRC} =32kHz, ADC off, WDT enable, LVR enable	—	40	65	μA
5V				—	80	130	

Symbol	Parameter	Test Conditions		Min.	Typ.	Max.	Unit
		V _{DD}	Conditions				
I _{STB}	IDLE0 Mode Standby Current (LXT On)	3V	No load, ADC off, WDT enable, LXTLP=0	—	2	4	μA
		5V		—	4	8	
		3V	No load, ADC off, WDT enable, LXTLP=1	—	1.5	3.0	
		5V		—	3.0	6.0	
	IDLE0 Mode Standby Current (LIRC On)	3V	No load, ADC off, WDT enable	—	1.5	3.0	μA
		5V		—	3.0	6.0	
	IDLE0 Mode Standby Current (LXT On)	3V	No load, ADC off, WDT enable, LXTLP=1, LCD enable, (R _T =1170kΩ without quick charge, V _{LCD} =V _{DD})	—	3.0	6.0	μA
		5V		—	6.0	12	
		3V	No load, ADC off, WDT enable, LXTLP=1, LCD enable, (R _T =225kΩ without quick charge, V _{LCD} =V _{DD})	—	14	28	
		5V		—	24	48	
		3V	No load, ADC off, WDT enable, LXTLP=1, LCD enable, (R _T =1170kΩ with quick charge, QCT[2:0]=0, V _{LCD} =V _{DD})	—	5	10	
		5V		—	9	18	
		3V	No load, ADC off, WDT enable, LXTLP=1, LCD enable, (R _T =1170kΩ with quick charge, QCT[2:0]=7, V _{LCD} =V _{DD})	—	11	22	
		5V		—	18	36	
IDLE1 Mode Standby Current (LIRC On)	3V	No load, ADC off, WDT enable, f _{sys} =8MHz on	—	0.5	3.0	mA	
	5V		—	1.0	6.0		
SLEEP0 Mode Standby Current (LXT or LIRC Off)	3V	No load, ADC off, WDT disable	—	0.2	1.0	μA	
	5V		—	0.4	2.0		
SLEEP1 Mode Standby Current (LXT or LIRC On)	3V	No load, ADC off, WDT enable	—	1.5	3.0	μA	
	5V		—	2.5	5.0		
V _{IL1}	Input Low Voltage for I/O Ports	—	—	0	—	0.3 V _{DD}	V
V _{IH1}	Input High Voltage for I/O Ports	—	—	0.7 V _{DD}	—	V _{DD}	V
GPIO (Except for PD0~PD7 & PE0~PE7)							
I _{OL}	I/O Port Sink Current	3V	V _{OL} =0.1V _{DD}	4	8	—	mA
		5V	V _{OL} =0.1V _{DD}	10	20	—	
I _{OH}	I/O Port Source Current	3V	V _{OH} =0.9V _{DD}	-2	-4	—	mA
		5V	V _{OH} =0.9V _{DD}	-5	-10	—	
High Sink I/O for LED Driver (PE0~PE7)							
I _{OL}	I/O Port Sink Current	3V	V _{OL} =0.1V _{DD}	8	16	—	mA
		5V	V _{OL} =0.1V _{DD}	20	40	—	
I _{OH}	I/O Port Source Current	3V	V _{OH} =0.9V _{DD}	-2	-4	—	mA
		5V	V _{OH} =0.9V _{DD}	-5	-10	—	
Adjustable Source I/O for LED Driver (PD0~PD7)							
I _{OL}	I/O Port Sink Current	3V	V _{OL} =0.1V _{DD}	4	8	—	mA
		5V	V _{OL} =0.1V _{DD}	10	20	—	

Symbol	Parameter	Test Conditions		Min.	Typ.	Max.	Unit
		V _{DD}	Conditions				
I _{OH}	I/O Port Source Current	3V	V _{OH} =0.9V _{DD} (IOHSn[1:0]=00B, n=0~7)	-2	-4	—	mA
			V _{OH} =0.9V _{DD} (IOHSn[1:0]=01B, n=0~7)	-0.67	-1.33	—	
			V _{OH} =0.9V _{DD} (IOHSn[1:0]=10B, n=0~7)	-0.5	-1	—	
			V _{OH} =0.9V _{DD} (IOHSn[1:0]=11B, n=0~7)	-0.33	-0.66	—	
		5V	V _{OH} =0.9V _{DD} (IOHSn[1:0]=00B, n=0~7)	-5	-10	—	
			V _{OH} =0.9V _{DD} (IOHSn[1:0]=01B, n=0~7)	-1.67	-3.33	—	
			V _{OH} =0.9V _{DD} (IOHSn[1:0]=10B, n=0~7)	-1.25	-2.5	—	
			V _{OH} =0.9V _{DD} (IOHSn[1:0]=11B, n=0~7)	-0.83	-1.67	—	
R _{PH}	Pull-high Resistance for I/O Ports	3V	—	20	60	100	kΩ
		5V	—	10	30	50	
R _T	LCD Total Bias Resistor	3V/5V	—	-30	R _T	+30	%
I _{TOL}	Total I/O Port Sink Current	5V	—	80	—	—	mA
I _{TOH}	Total I/O Port Source Current	5V	—	-80	—	—	mA

A.C. Characteristics

T_a=25°C

Symbol	Parameter	Test Conditions		Min.	Typ.	Max.	Unit
		V _{DD}	Conditions				
f _{CPU}	Operating Clock	—	2.2~5.5V	DC	—	4	MHz
			2.2~5.5V	DC	—	8	
			2.7~5.5V	DC	—	12	
			4.5~5.5V	DC	—	16	
f _{SYS}	System Clock (HIRC)	2.2V~5.5V	—	—	8	—	MHz
f _{HIRC}	8MHz Writer Trimmed HIRC Frequency	3V/5V	T _a =25°C	-1%	8	+1%	MHz
			T _a =-40~85°C	-2%	8	+2%	
		2.2V~5.5V	T _a =25°C	-2.5%	8	+2.5%	
			T _a =-40°C ~ 85°C	-3%	8	+3%	
f _{LIRC}	System Clock (LIRC)	5V	T _a =25°C	-10%	32	+10%	kHz
t _{TIMER}	TCKn Input Pulse Width	—	—	0.3	—	—	μs
t _{INT}	Interrupt Pulse Width	—	—	10	—	—	μs
t _{EERD}	EEPROM read time	5V	—	—	2	4	t _{sys}
t _{EEWR}	EEPROM Write Time	5V	—	—	4	6	ms
t _{RSTD}	System Reset Delay Time (POR Reset, LVR Hardware Reset, LVR Software Reset, WDT Software Reset)	—	—	25	50	100	ms
	System Reset Delay Time (WDT Time-out Hardware Cold Reset)	—	—	8.3	16.7	33.3	ms

Symbol	Parameter	Test Conditions		Min.	Typ.	Max.	Unit
		V _{DD}	Conditions				
t _{SST}	System Start-up Timer Period (Power on Reset)	—	f _{SYS} =f _{HIRC}	1024	—	—	t _{HIRC}
		—	f _{SYS} =f _{HXT}	1024	—	—	t _{HXT}
	System Start-up Timer Period (Wake-up from Power Down Mode where f _{SYS} is off)	—	f _{SYS} =f _{LXT}	1024	—	—	t _{LXT}
		—	f _{SYS} =f _{HXT} ~ f _{HXT} / 64	1024	—	—	t _{HXT}
		—	f _{SYS} =f _{HIRC} ~ f _{HIRC} / 64	16	—	—	t _{HIRC}
	System Start-up Timer Period (Wake-up from Power Down Mode where f _{SYS} is on)	—	f _{SYS} =f _H ~ f _H / 64, f _H =f _{HXT} or f _{HIRC}	2	—	—	f _H
—		f _{SYS} =f _{LXT} or f _{LIRC}	2	—	—	f _{SUB}	
t _{SRESET}	Software Reset Width to Reset	—	—	45	90	120	μs

Note: 1. t_{SYS} = 1/f_{SYS}

2. To maintain the accuracy of the internal HIRC oscillator frequency, a 0.1μF decoupling capacitor should be connected between V_{DD} and V_{SS} and located as close to the device as possible.

A/D Converter Electrical Characteristics

T_a=25°C

Symbol	Parameter	Test Conditions		Min.	Typ.	Max.	Unit
		V _{DD}	Conditions				
AV _{DD}	A/D Converter Operating Voltage	—	—	2.7	—	5.5	V
V _{ADI}	A/D Converter Input Voltage	—	—	0	—	AV _{DD} / V _{REF}	V
V _{REF}	A/D Converter Reference Voltage	—	—	2	—	AV _{DD}	V
DNL	Differential Non-linearity	3V	V _{REF} =V _{DD} , t _{ADCK} =0.5μs	-4	—	+4	LSB
		5V	V _{REF} =V _{DD} , t _{ADCK} =0.5μs				
		3V	V _{REF} =V _{DD} , t _{ADCK} =10μs				
		5V	V _{REF} =V _{DD} , t _{ADCK} =10μs				
INL	Integral Non-linearity	3V	V _{REF} =V _{DD} , t _{ADCK} =0.5μs	-7	—	+7	LSB
		5V	V _{REF} =V _{DD} , t _{ADCK} =0.5μs				
		3V	V _{REF} =V _{DD} , t _{ADCK} =10μs				
		5V	V _{REF} =V _{DD} , t _{ADCK} =10μs				
I _{ADC}	Additional Current for ADC Enable	3V	No load (t _{ADCK} =0.5μs)	—	0.9	1.35	mA
		5V	No load (t _{ADCK} =0.5μs)	—	1.2	1.8	
t _{ADCK}	A/D Converter Clock Period	—	—	0.5	—	10	μs
t _{ON2ST}	ADC On-to-Start Time	—	—	2	—	—	μs
t _{ADS}	A/D Converter Sampling Time	—	—	—	4	—	t _{ADCK}
t _{ADC}	Conversion Time (Include ADC Sample and Hold Time)	—	12-bit ADC	—	16	—	t _{ADCK}

Reference Voltage Characteristics

T_a=25°C

Symbol	Parameter	Test Conditions		Min.	Typ.	Max.	Unit
		V _{DD}	Conditions				
V _{BG}	Reference with Buffer Voltage	—	—	-3%	1.09	+3%	V
I _{BG}	Addition Power Consumption if V _{BG} Reference With Buffer is Used	—	—	—	200	300	μA
t _{BGS}	V _{BG} Turn on Stable Time	—	—	—	—	200	μs

Note: The V_{BG} voltage is used as the A/D converter internal signal input.

LVD/LVR Electrical Characteristics

Ta=25°C

Symbol	Parameter	Test Conditions		Min.	Typ.	Max.	Unit
		V _{DD}	Conditions				
V _{LVR}	Low Voltage Reset Voltage	—	LVR enable, voltage select 2.1V	- 5%	2.1	+ 5%	V
		—	LVR enable, voltage select 2.55V	- 5%	2.55	+ 5%	
		—	LVR enable, voltage select 3.15V	- 5%	3.15	+ 5%	
		—	LVR enable, voltage select 3.8V	- 5%	3.8	+ 5%	
V _{LVD}	Low Voltage Detection Voltage	—	LVD enable, voltage select 2.0V	- 5%	2.0	+ 5%	V
		—	LVD enable, voltage select 2.2V	- 5%	2.2	+ 5%	
		—	LVD enable, voltage select 2.4V	- 5%	2.4	+ 5%	
		—	LVD enable, voltage select 2.7V	- 5%	2.7	+ 5%	
		—	LVD enable, voltage select 3.0V	- 5%	3.0	+ 5%	
		—	LVD enable, voltage select 3.3V	- 5%	3.3	+ 5%	
		—	LVD enable, voltage select 3.6V	- 5%	3.6	+ 5%	
		—	LVD enable, voltage select 4.0V	- 5%	4.0	+ 5%	
I _{LVD}	Additional Power Consumption if LVD is Used	3V	LVD disable → LVD enable (LVR enable)	—	30	45	μA
		5V		—	60	90	
t _{LVDS}	LVDO Stable Time	—	For LVR enable, LVD off → on	—	—	15	μs
t _{LVR}	Minimum Low Voltage Width to Reset	—	—	120	240	480	μs
t _{LVD}	Minimum Low Voltage Width to Interrupt	—	—	60	120	240	μs

Power-on Reset Characteristics

Ta=25°C

Symbol	Parameter	Test Conditions		Min.	Typ.	Max.	Unit
		V _{DD}	Conditions				
V _{POR}	V _{DD} Start Voltage to Ensure Power-on Reset	—	—	—	—	100	mV
RR _{POR}	V _{DD} Rising Rate to Ensure Power-on Reset	—	—	0.035	—	—	V/ms
t _{POR}	Minimum Time for V _{DD} Stays at V _{POR} to Ensure Power-on Reset	—	—	1	—	—	ms

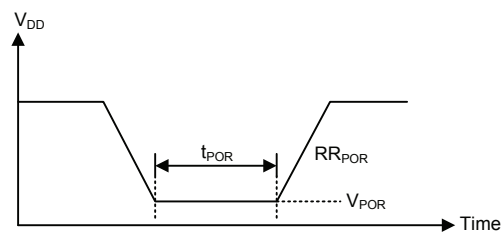

System Architecture

A key factor in the high-performance features of the range of microcontrollers is attributed to their internal system architecture. The device takes advantage of the usual features found within RISC microcontrollers providing increased speed of operation and enhanced performance. The pipelining scheme is implemented in such a way that instruction fetching and instruction execution are overlapped, hence instructions are effectively executed in one or two cycles for most of the standard or extended instructions respectively. The exceptions to this are branch or call instructions which need one more cycle. An 8-bit wide ALU is used in practically all instruction set operations, which carries out arithmetic operations, logic operations, rotation, increment, decrement, branch decisions, etc. The internal data path is simplified by moving data through the Accumulator and the ALU. Certain internal registers are implemented in the Data Memory and can be directly or indirectly addressed. The simple addressing methods of these registers along with additional architectural features ensure that a minimum of external components is required to provide a functional I/O and A/D control system with maximum reliability and flexibility. This makes the device suitable for low-cost, high-volume production for controller applications.

Clocking and Pipelining

The main system clock, derived from either a HXT, LXT, HIRC or LIRC oscillator is subdivided into four internally generated non-overlapping clocks, T1~T4. The Program Counter is incremented at the beginning of the T1 clock during which time a new instruction is fetched. The remaining T2~T4 clocks carry out the decoding and execution functions. In this way, one T1~T4 clock cycle forms one instruction cycle. Although the fetching and execution of instructions takes place in consecutive instruction cycles, the pipelining structure of the microcontroller ensures that instructions are effectively executed in one instruction cycle. The exception to this are instructions where the contents of the Program Counter are changed, such as subroutine calls or jumps, in which case the instruction will take one more instruction cycle to execute.

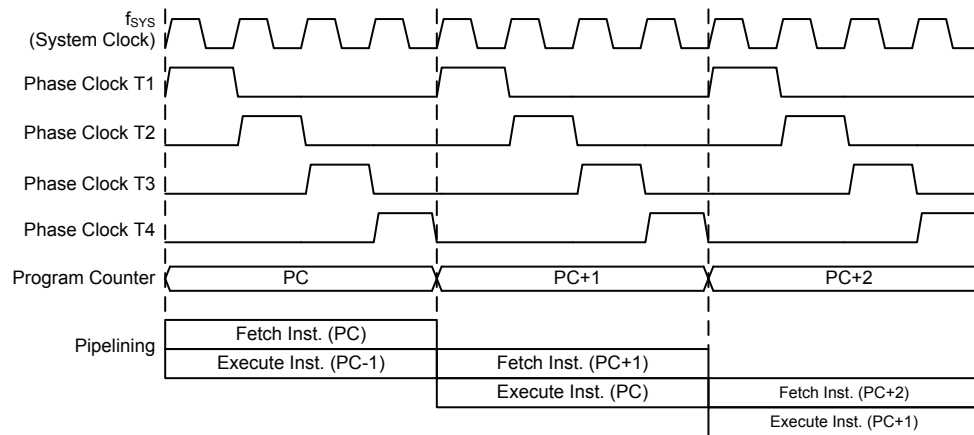

System Clocking and Pipelining

For instructions involving branches, such as jump or call instructions, two machine cycles are required to complete instruction execution. An extra cycle is required as the program takes one cycle to first obtain the actual jump or call address and then another cycle to actually execute the branch. The requirement for this extra cycle should be taken into account by programmers in timing sensitive applications.

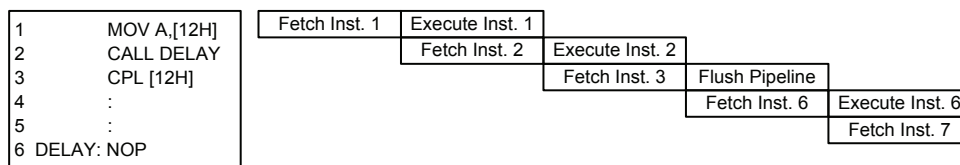

Instruction Fetching

Program Counter

During program execution, the Program Counter is used to keep track of the address of the next instruction to be executed. It is automatically incremented by one each time an instruction is executed except for instructions, such as "JMP" or "CALL" that demands a jump to a non-consecutive Program Memory address. Only the lower 8 bits, known as the Program Counter Low Register, are directly addressable by the application program.

When executing instructions requiring jumps to non-consecutive addresses such as a jump instruction, a subroutine call, interrupt or reset, etc., the microcontroller manages program control by loading the required address into the Program Counter. For conditional skip instructions, once the condition has been met, the next instruction, which has already been fetched during the present instruction execution, is discarded and a dummy cycle takes its place while the correct instruction is obtained.

Program Counter	
Program Counter High Byte	PCL Register
PC12~PC8	PCL7~PCL0

Program Counter

The lower byte of the Program Counter, known as the Program Counter Low register or PCL, is available for program control and is a readable and writeable register. By transferring data directly into this register, a short program jump can be executed directly. However, as only this low byte is available for manipulation, the jumps are limited to the present page of memory, that is 256 locations. When such program jumps are executed it should also be noted that a dummy cycle will be inserted. Manipulating the PCL register may cause program branching, so an extra cycle is needed to pre-fetch.

Stack

This is a special part of the memory which is used to save the contents of the Program Counter only. The stack is organized into 8 levels and is neither part of the data nor part of the program space, and is neither readable nor writeable. The activated level is indexed by the Stack Pointer, and is neither readable nor writeable. At a subroutine call or interrupt acknowledge signal, the contents of the Program Counter are pushed onto the stack. At the end of a subroutine or an interrupt routine, signaled by a return instruction, RET or RETI, the Program Counter is restored to its previous value from the stack. After a device reset, the Stack Pointer will point to the top of the stack.

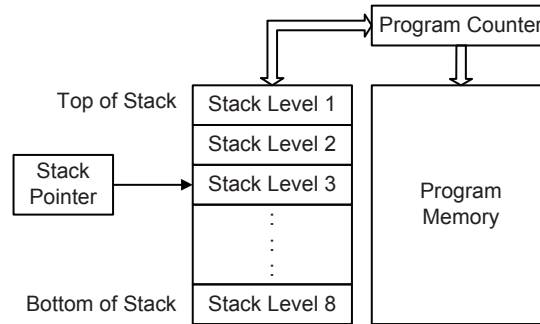

If the stack is full and an enabled interrupt takes place, the interrupt request flag will be recorded but the acknowledge signal will be inhibited. When the Stack Pointer is decremented, by RET or RETI, the interrupt will be serviced. This feature prevents stack overflow allowing the programmer to use the structure more easily. However, when the stack is full, a CALL subroutine instruction can still be executed which will result in a stack overflow. Precautions should be taken to avoid such cases which might cause unpredictable program branching. If the stack is overflow, the first Program Counter save in the stack will be lost.

Arithmetic and Logic Unit – ALU

The arithmetic-logic unit or ALU is a critical area of the microcontroller that carries out arithmetic and logic operations of the instruction set. Connected to the main microcontroller data bus, the ALU receives related instruction codes and performs the required arithmetic or logical operations after which the result will be placed in the specified register. As these ALU calculation or operations may result in carry, borrow or other status changes, the status register will be correspondingly updated to reflect these changes. The ALU supports the following functions:

- Arithmetic operations:
ADD, ADDM, ADC, ADCM, SUB, SUBM, SBC, SBCM, DAA
LADD, LADDM, LADC, LADCM, LSUB, LSUBM, LSBC, LSBCM, LDAA
- Logic operations:
AND, OR, XOR, ANDM, ORM, XORM, CPL, CPLA
LAND, LANDM, LOR, LORM, LXOR, LXORM, LCPL, LCPLA
- Rotation:
RRA, RR, RRCA, RRC, RLA, RL, RLCA, RLC
LRR, LRRCA, LRRCA, LRRCA, LRLA, LRL, LRLCA, LRLC
- Increment and Decrement:
INCA, INC, DECA, DEC, LINCA, LINC, LDECA, LDEC
- Branch decision:
JMP, SZ, SZA, SNZ, SIZ, SDZ, SIZA, SDZA, CALL, RET, RETI
LSNZ, LSZ, LSZA, LSIZ, LSIZA, LSDZ, LSDZA

Flash Program Memory

The Program Memory is the location where the user code or program is stored. For this device the Program Memory is Flash type, which means it can be programmed and re-programmed a large number of times, allowing the user the convenience of code modification on the same device. By using the appropriate programming tools, the Flash device offer users the flexibility to conveniently debug and develop their applications while also offering a means of field programming and updating.

Structure

The Program Memory has a capacity of 8K×16 bits. The Program Memory is addressed by the Program Counter and also contains data, table information and interrupt entries. Table data, which can be setup in any location within the Program Memory, is addressed by a separate table pointer register.

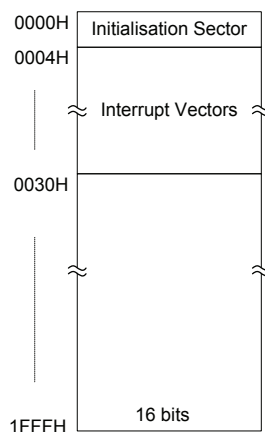

Program Memory Structure

Special Vectors

Within the Program Memory, certain locations are reserved for the reset and interrupts. The location 0000H is reserved for use by the device reset for program initialisation. After a device reset is initiated, the program will jump to this location and begin execution.

Look-up Table

Any location within the Program Memory can be defined as a look-up table where programmers can store fixed data. To use the look-up table, the table pointer must first be setup by placing the address of the look up data to be retrieved in the table pointer register, TBLP and TBHP. These registers define the total address of the look-up table.

After setting up the table pointer, the table data can be retrieved from the Program Memory using the corresponding table read instruction such as "TABRD [m]" or "TABRDL [m]" respectively when the memory [m] is located in sector 0. If the memory [m] is located in other sectors, the data can be retrieved from the program memory using the corresponding extended table read instruction such as "LTABRD [m]" or "LTABRDL [m]" respectively. When the instruction is executed, the lower order table byte from the Program Memory will be transferred to the user defined Data Memory register [m] as specified in the instruction. The higher order table data byte from the Program Memory will be transferred to the TBLH special register.

The accompanying diagram illustrates the addressing data flow of the look-up table.

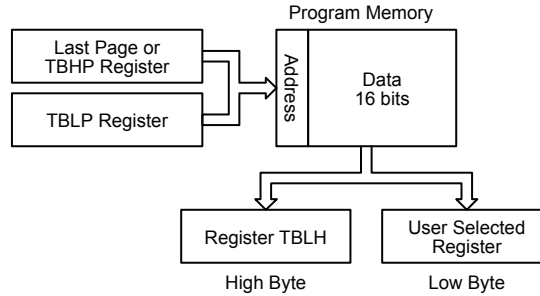

Table Program Example

The following example shows how the table pointer and table data is defined and retrieved from the microcontroller. This example uses raw table data located in the Program Memory which is stored there using the ORG statement. The value at this ORG statement is "1F00H" which refers to the start address of the last page within the 8K Program Memory of the microcontroller. The table pointer low byte register is setup here to have an initial value of "06H". This will ensure that the first data read from the data table will be at the Program Memory address "1F06H" or 6 locations after the start of the last page. Note that the value for the table pointer is referenced to the address specified by TBLP and TBHP if the "TABRD [m]" or "LTABRD [m]" instruction is being used. The high byte of the table data which in this case is equal to zero will be transferred to the TBLH register automatically when the "TABRD [m]" or "LTABRD [m]" instruction is executed.

Because the TBLH register is a read/write register and can be restored, care should be taken to ensure its protection if both the main routine and Interrupt Service Routine use table read instructions. If using the table read instructions, the Interrupt Service Routines may change the value of the TBLH and subsequently cause errors if used again by the main routine. As a rule it is recommended that simultaneous use of the table read instructions should be avoided. However, in situations where simultaneous use cannot be avoided, the interrupts should be disabled prior to the execution of any main routine table-read instructions. Note that all table related instructions require two instruction cycles to complete their operation.

Table Read Program Example

```

tempreg1 db ? ; temporary register #1
tempreg2 db ? ; temporary register #2
:
:
mov a,06h      ; initialise low table pointer - note that this address is referenced
mov tblp,a    ; to the last page or the page that tbhp pointed
mov a,1Fh     ; initialise high table pointer
mov tbhp,a
:
:
tabrd tempreg1 ; transfers value in table referenced by table pointer data at program
               ; memory address "1F06H" transferred to tempreg1 and TBLH
dec tblp      ; reduce value of table pointer by one
tabrd tempreg2 ; transfers value in table referenced by table pointer
               ; data at program memory address "1F05H" transferred to
               ; tempreg2 and TBLH in this example the data "1AH" is
               ; transferred to tempreg1 and data "0FH" to register tempreg2
:
:
org 1F00h     ; sets initial address of program memory
dc 00Ah, 00Bh, 00Ch, 00Dh, 00Eh, 00Fh, 01Ah, 01Bh
:
:

```

In Circuit Programming – ICP

The provision of Flash type Program Memory provides the user with a means of convenient and easy upgrades and modifications to their programs on the same device. As an additional convenience, a means of programming the microcontroller in-circuit has provided using a 4-pin interface. This provides manufacturers with the possibility of manufacturing their circuit boards complete with a programmed or un-programmed microcontroller, and then programming or upgrading the program at a later stage. This enables product manufacturers to easily keep their manufactured products supplied with the latest program releases without removal and re-insertion of the device.

The Flash MCU to Writer Programming Pin correspondence table is as follows:

Writer Pins	MCU Programming Pins	Pin Description
ICPDA	PA0	Programming serial data/address
ICPCK	PA2	Programming clock
VDD	VDD	Power supply
VSS	VSS	Ground

The Program Memory and EEPROM data Memory can both be programmed serially in-circuit using this 4-wire interface. Data is downloaded and uploaded serially on a single pin with an additional line for the clock. Two additional lines are required for the power supply. The technical details regarding the in-circuit programming of the device are beyond the scope of this document and will be supplied in supplementary literature.

During the programming process, taking control of the ICPDA and ICPCK pins for data and clock programming purposes. The user must there take care to ensure that no other outputs are connected to these two pins.

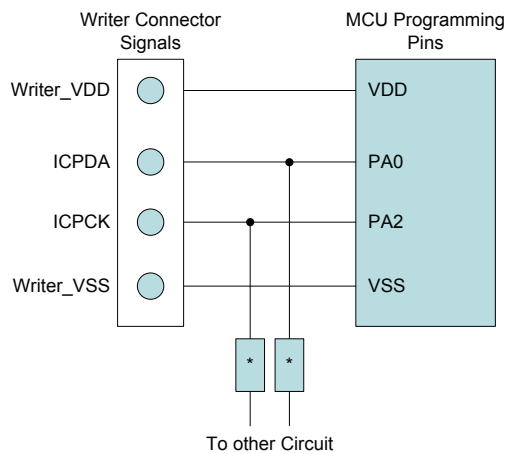

Note: * may be resistor or capacitor. The resistance of * must be greater than 1kΩ or the capacitance of * must be less than 1nF.

On-Chip Debug Support – OCDS

An EV chip exists for the purposes of device emulation. This EV chip device also provides an "On-Chip Debug" function to debug the device during the development process. The EV chip and the actual MCU device are almost functionally compatible except for the "On-Chip Debug" function. Users can use the EV chip device to emulate the real chip device behavior by connecting the OCDSDA and OCDSCK pins to the HT-IDE development tools. The OCDSDA pin is the OCDS Data/Address input/output pin while the OCDSCK pin is the OCDS clock input pin. When users use the EV chip for debugging, other functions which are shared with the OCDSDA and OCDSCK pins in the actual MCU device will have no effect in the EV chip. However, the two OCDS pins which are pin-shared with the ICP programming pins are still used as the Flash Memory programming pins for ICP. For a more detailed OCDS description, refer to the corresponding document named "Holtek e-Link for 8-bit MCU OCDS User's Guide".

e-Link Pins	EV Chip Pins	Pin Description
OCDSDA	OCDSDA	On-chip debug support data/address input/output
OCDSCK	OCDSCK	On-chip debug support clock input
VDD	VDD	Power supply
VSS	VSS	Ground

RAM Data Memory

The Data Memory is a volatile area of 8-bit wide RAM internal memory and is the location where temporary information is stored.

Categorized into three types, the first of these is an area of RAM where special function registers are located. These registers have fixed locations and are necessary for correct operation of the device. Many of these registers can be read from and written to directly under program control, however, some remain protected from user manipulation. The second area of Data Memory is reserved for general purpose use. All locations within this area are read and write accessible under program control. The third area is used for the LCD Data Memory. This special area of Data Memory is mapped directly to the LCD display so data written into this memory area will directly affect the displayed data.

Structure

The Data Memory is subdivided into several sectors, all of which are implemented in 8-bit wide RAM. Each of the Data Memory Sector is categorized into two types, the special Purpose Data Memory and the General Purpose Data Memory. While the 80H~9FH of Sector 1 is LCD Data Memory.

The start address of the Data Memory for the device is the address 00H. Switching between the different Data Memory sectors is achieved by setting the Memory Pointers to the correct value.

Special Purpose Data Memory	LCD Data Memory		General Purpose Data Memory	
Available Sectors	Capacity	Sector: Address	Capacity	Sector: Address
0,1,2,3	32×8	1: 80H~9FH	384×8	0: 80H~FFH 2: 80H~FFH 3: 80H~FFH

Data Memory Summary

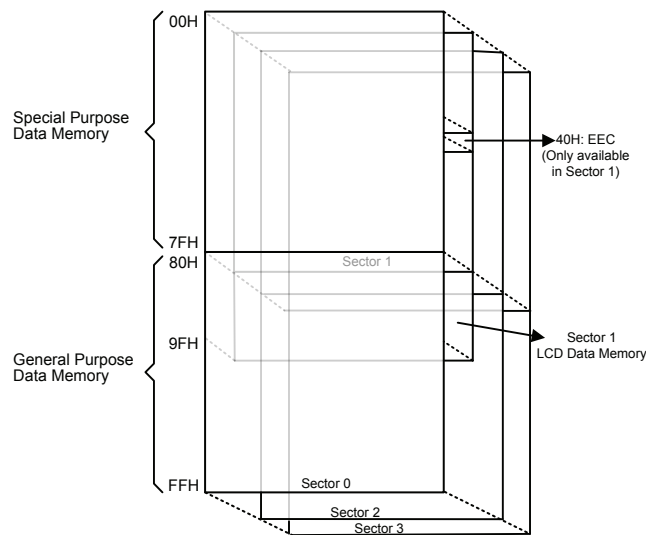

Data Memory Structure

Data Memory Addressing

For the device that supports the extended instructions, there is no Bank Pointer for Data Memory addressing. For Data Memory the desired Sector is pointed by the MP1H or MP2H register and the certain Data Memory address in the selected sector is specified by the MP1L or MP2L register when using indirect addressing access.

Direct Addressing can be used in all sectors using the corresponding instruction which can address all available data memory space. For the accessed data memory which is located in any data memory sectors except sector 0, the extended instructions can be used to access the data memory instead of using the indirect addressing access. The main difference between standard instructions and extended instructions is that the data memory address "m" in the extended instructions has 10 valid bits depending on which device is selected, the high byte indicates a sector and the low byte indicates a specific address.

General Purpose Data Memory

All microcontroller programs require an area of read/write memory where temporary data can be stored and retrieved for use later. It is this area of RAM memory that is known as General Purpose Data Memory. This area of Data Memory is fully accessible by the user programing for both reading and writing operations. By using the bit operation instructions individual bits can be set or reset under program control giving the user a large range of flexibility for bit manipulation in the Data Memory.

Special Purpose Data Memory

This area of Data Memory is where registers, necessary for the correct operation of the microcontroller, are stored. Most of the registers are both readable and writeable but some are protected and are readable only, the details of which are located under the relevant Special Function Register section. Note that for locations that are unused, any read instruction to these addresses will return the value "00H".

Sector 0,2,3 Sector 1		Sector 0,2,3 Sector 1	
00H	IAR0	40H	EEC
01H	MP0	41H	USR
02H	IAR1	42H	UCR1
03H	MP1L	43H	UCR2
04H	MP1H	44H	BRG
05H	ACC	45H	TXR/RXR
06H	PCL	46H	
07H	TBLP	47H	TMPC
08H	TBLH	48H	TM2C0
09H	TBHP	49H	TM2C1
0AH	STATUS	4AH	TM2DL
0BH		4BH	TM2DH
0CH	IAR2	4CH	TM2AL
0DH	MP2L	4DH	TM2AH
0EH	MP2H	4EH	TM3C0
0FH	SMOD	4FH	TM3C1
10H	TBC	50H	TM3DL
11H	WDC	51H	TM3DH
12H	LVDC	52H	TM3AL
13H	LVRC	53H	TM3AH
14H	CTRL	54H	
15H	FSUBC	55H	
16H	INTEG	56H	
17H	INTC0	57H	
18H	INTC1	58H	LCDC0
19H	INTC2	59H	LCDC1
1AH	MFIO	5AH	SEGCR0
1BH	MF11	5BH	SEGCR1
1CH	MF12	5CH	SEGCR2
1DH	MF13	5DH	SEGCR3
1EH	PAWU	5EH	PCPU
1FH	PAPU	5FH	PC
20H	PA	60H	PCC
21H	PAC	61H	PDPU
22H	PBPU	62H	PD
23H	PB	63H	PDC
24H	PBC	64H	PEPU
25H	IOHR0	65H	PE
26H	IOHR1	66H	PEC
27H	MF14	67H	PFFPU
28H	ADRL	68H	PF
29H	ADRH	69H	PFC
2AH	ADCR0	6AH	PGPU
2BH	ADCR1	6BH	PG
2CH	ACERL	6CH	PGC
2DH	ACERH	6DH	SIMC0
2EH	TM0C0	6EH	SIMC1
2FH	TM0C1	6FH	SIMD
30H	TM0DL	70H	SIMA/SIMC2
31H	TM0DH	71H	SIMTOC
32H	TM0AL	72H	
33H	TM0AH	73H	
34H	TM0RPL	74H	
35H	TM0RPH	75H	
36H	TM1C0	76H	
37H	TM1C1	77H	
38H	TM1DL	78H	
39H	TM1DH	79H	
3AH	TM1AL	7AH	
3BH	TM1AH	7BH	
3CH	INTC3	7CH	
3DH	EEA	7DH	
3EH	EED	7EH	
3FH		7FH	

□ : Unused, read as 00H ■ : Reserved, cannot be changed

Special Purpose Data Memory

Special Function Register Description

Most of the Special Function Register details will be described in the relevant functional sections□ however several registers require a separate description in this section.

Indirect Addressing Registers – IAR0, IAR1, IAR2

The Indirect Addressing Registers, IAR0, IAR1 and IAR2, although having their locations in normal RAM register space, do not actually physically exist as normal registers. The method of indirect addressing for RAM data manipulation uses these Indirect Addressing Registers and Memory Pointers, in contrast to direct memory addressing, where the actual memory address is specified. Actions on the IAR0, IAR1 and IAR2 registers will result in no actual read or write operation to these registers but rather to the memory location specified by their corresponding Memory Pointers, MP0, MP1L/MP1H or MP2L/MP2H. Acting as a pair, IAR0 and MP0 can together access data only from Sector 0 while the IAR1 register together with the MP1L/MP1H register pair and IAR2 register together with the MP2L/MP2H register pair can access data from any Data Memory Sector. As the Indirect Addressing Registers are not physically implemented, reading the Indirect Addressing Registers will return a result of "00H" and writing to the registers will result in no operation.

Memory Pointers – MP0, MP1L, MP1H, MP2L, MP2H

Five Memory Pointers, known as MP0, MP1L, MP1H, MP2L, MP2H, are provided. These Memory Pointers are physically implemented in the Data Memory and can be manipulated in the same way as normal registers providing a convenient way with which to address and track data. When any operation to the relevant Indirect Addressing Registers is carried out, the actual address that the microcontroller is directed to is the address specified by the related Memory Pointer. MP0, together with Indirect Addressing Register, IAR0, are used to access data from Sector 0, while MP1L/MP1H together with IAR1 and MP2L/MP2H together with IAR2 are used to access data from all sectors according to the corresponding MP1H or MP2H register. Direct Addressing can be used in all sectors using the corresponding instruction which can address all available data memory space.

The following example shows how to clear a section of four Data Memory locations already defined as locations adres1 to adres4.

Indirect Addressing Program Example 1

```
data .section 'data'
adres1 db ?
adres2 db ?
adres3 db ?
adres4 db ?
block db ?
code .section at 0 'code'
org 00h
start:
    mov a, 04h                ; setup size of block
    mov block, a
    mov a, offset adres1     ; Accumulator loaded with first RAM address
    mov mp0, a               ; setup memory pointer with first RAM address
loop:
    clr IAR0                 ; clear the data at address defined by MP0
    inc mp0                  ; increment memory pointer
    sdz block                 ; check if last memory location has been cleared
    jmp loop
continue:
```

Indirect Addressing Program Example 2

```
data .section 'data'
adres1 db ?
adres2 db ?
adres3 db ?
adres4 db ?
block db ?
code .section at 0 'code'
org 00h
start:
    mov a, 04h                ; setup size of block
    mov block, a
    mov a, 01h                ; setup the memory sector
    mov mplh, a
    mov a, offset adres1     ; Accumulator loaded with first RAM address
    mov mpll, a              ; setup memory pointer with first RAM address
loop:
    clr IAR1                 ; clear the data at address defined by MPLL
    inc mpll                 ; increment memory pointer MPLL
    sdz block                ; check if last memory location has been cleared
    jmp loop
continue:
```

The important point to note here is that in the example shown above, no reference is made to specific Data Memory addresses.

Direct Addressing Program Example using extended instructions

```
data .section 'data'
temp db ?
code .section at 0 'code'
org 00h
start:
    lmov a, [m]              ; move [m] data to acc
    lsub a, [m+1]           ; compare [m] and [m+1] data
    snz c                   ; [m]>[m+1]?
    jmp continue           ; no
    lmov a, [m]             ; yes, exchange [m] and [m+1] data
    mov temp, a
    lmov a, [m+1]
    lmov [m], a
    mov a, temp
    lmov [m+1], a
continue:
```

Note: here "m" is a data memory address located in any data memory sectors. For example, m=1F0H, it indicates address 0F0H in Sector 1.

Accumulator – ACC

The Accumulator is central to the operation of any microcontroller and is closely related with operations carried out by the ALU. The Accumulator is the place where all intermediate results from the ALU are stored. Without the Accumulator it would be necessary to write the result of each calculation or logical operation such as addition, subtraction, shift, etc., to the Data Memory resulting in higher programming and timing overheads. Data transfer operations usually involve the temporary storage function of the Accumulator; for example, when transferring data between one user-defined register and another, it is necessary to do this by passing the data through the Accumulator as no direct transfer between two registers is permitted.

Program Counter Low Register – PCL

To provide additional program control functions, the low byte of the Program Counter is made accessible to programmers by locating it within the Special Purpose area of the Data Memory. By manipulating this register, direct jumps to other program locations are easily implemented. Loading a value directly into this PCL register will cause a jump to the specified Program Memory location, however, as the register is only 8-bit wide, only jumps within the current Program Memory page are permitted. When such operations are used, note that a dummy cycle will be inserted.

Look-up Table Registers – TBLP, TBHP, TBLH

These three special function registers are used to control operation of the look-up table which is stored in the Program Memory. TBLP and TBHP are the table pointers and indicate the location where the table data is located. Their value must be setup before any table read commands are executed. Their value can be changed, for example using the "INC" or "DEC" instructions, allowing for easy table data pointing and reading. TBLH is the location where the high order byte of the table data is stored after a table read data instruction has been executed. Note that the lower order table data byte is transferred to a user defined location.

Status Register – STATUS

This 8-bit register contains the SC flag, CZ flag, zero flag (Z), carry flag (C), auxiliary carry flag (AC), overflow flag (OV), power down flag (PDF), and watchdog time-out flag (TO). These arithmetic/logical operation and system management flags are used to record the status and operation of the microcontroller.

With the exception of the TO and PDF flags, bits in the status register can be altered by instructions like most other registers. Any data written into the status register will not change the TO or PDF flag. In addition, operations related to the status register may give different results due to the different instruction operations. The TO flag can be affected only by a system power-up, a WDT time-out or by executing the "CLR WDT" or "HALT" instruction. The PDF flag is affected only by executing the "HALT" or "CLR WDT" instruction or during a system power-up.

The Z, OV, AC, C, SC and CZ flags generally reflect the status of the latest operations.

- C is set if an operation results in a carry during an addition operation or if a borrow does not take place during a subtraction operation; otherwise C is cleared. C is also affected by a rotate through carry instruction.
- AC is set if an operation results in a carry out of the low nibbles in addition, or no borrow from the high nibble into the low nibble in subtraction; otherwise AC is cleared.
- Z is set if the result of an arithmetic or logical operation is zero; otherwise Z is cleared.
- OV is set if an operation results in a carry into the highest-order bit but not a carry out of the highest-order bit, or vice versa; otherwise OV is cleared.
- PDF is cleared by a system power-up or executing the "CLR WDT" instruction. PDF is set by executing the "HALT" instruction.
- TO is cleared by a system power-up or executing the "CLR WDT" or "HALT" instruction. TO is set by a WDT time-out.
- CZ is the operational result of different flags for different instructions. Refer to register definitions for more details.
- SC is the result of the "XOR" operation which is performed by the OV flag and the MSB of the current instruction operation result.

In addition, on entering an interrupt sequence or executing a subroutine call, the status register will not be pushed onto the stack automatically. If the contents of the status registers are important and if the subroutine can corrupt the status register, precautions must be taken to correctly save it.

STATUS Register

Bit	7	6	5	4	3	2	1	0
Name	SC	CZ	TO	PDF	OV	Z	AC	C
R/W	R/W	R/W	R	R	R/W	R/W	R/W	R/W
POR	x	x	0	0	x	x	x	x

"x" unknown

- Bit 7 **SC**: XOR Operation Result - performed by the OV flag and the MSB of the instruction operation result.
- Bit 6 **CZ**: Operational Result of Different Flags for Different Instructions.
 For SUB/SUBM/LSUB/LSUBM instructions, the CZ flag is equal to the Z flag.
 For SBC/SBCM/LSBC/LSBCM instructions, the CZ flag is the "AND" operation result which is performed by the previous operation CZ flag and current operation zero flag.
 For other instructions, the CZ flag will not be affected.
- Bit 5 **TO**: Watchdog Time-Out Flag
 0: After power up or executing the "CLR WDT" or "HALT" instruction
 1: A watchdog time-out occurred.
- Bit 4 **PDF**: Power Down Flag
 0: After power up or executing the "CLR WDT" instruction
 1: By executing the "HALT" instruction
- Bit 3 **OV**: Overflow Flag
 0: No overflow
 1: An operation results in a carry into the highest-order bit but not a carry out of the highest-order bit or vice versa.
- Bit 2 **Z**: Zero Flag
 0: The result of an arithmetic or logical operation is not zero
 1: The result of an arithmetic or logical operation is zero
- Bit 1 **AC**: Auxiliary flag
 0: No auxiliary carry
 1: An operation results in a carry out of the low nibbles in addition, or no borrow from the high nibble into the low nibble in subtraction
- Bit 0 **C**: Carry Flag
 0: No carry-out
 1: An operation results in a carry during an addition operation or if a borrow does not take place during a subtraction operation
 C is also affected by a rotate through carry instruction.

EEPROM Data Memory

This device contains an area of internal EEPROM Data Memory. EEPROM, which stands for Electrically Erasable Programmable Read Only Memory, is by its nature a non-volatile form of re-programmable memory, with data retention even when its power supply is removed. By incorporating this kind of data memory, a whole new host of application possibilities are made available to the designer. The availability of EEPROM storage allows information such as product identification numbers, calibration values, specific user data, system setup data or other product information to be stored directly within the product microcontroller. The process of reading and writing data to the EEPROM memory has been reduced to a very trivial affair.

EEPROM Data Memory Structure

The EEPROM Data Memory capacity is 64×8 bits for the device. Unlike the Program Memory and RAM Data Memory, the EEPROM Data Memory is not directly mapped into memory space and is therefore not directly addressable in the same way as the other types of memory. Read and Write operations to the EEPROM are carried out in single byte operations using an address and a data register in Sector 0 and a single control register in Sector 1.

EEPROM Registers

Three registers control the overall operation of the internal EEPROM Data Memory. These are the address register, EEA, the data register, EED and a single control register, EEC. As both the EEA and EED registers are located in Sector 0, they can be directly accessed in the same way as any other Special Function Register. The EEC register however, being located in Sector 1, can be read from or written to indirectly using the MP1L/MP1H or MP2L/MP2H Memory Pointer and Indirect Addressing Register, IAR1/IAR2. Because the EEC control register is located at address 40H in Sector 1, the MP1L or MP2L Memory Pointer must first be set to the value 40H and the MP1H or MP2H Memory Pointer high byte set to the value, 01H, before any operations on the EEC register are executed.

Register Name	Bit							
	7	6	5	4	3	2	1	0
EEA	—	—	D5	D4	D3	D2	D1	D0
EED	D7	D6	D5	D4	D3	D2	D1	D0
EEC	—	—	—	—	WREN	WR	RDEN	RD

EEPROM Register List

EEA Register

Bit	7	6	5	4	3	2	1	0
Name	—	—	D5	D4	D3	D2	D1	D0
R/W	—	—	R/W	R/W	R/W	R/W	R/W	R/W
POR	—	—	0	0	0	0	0	0

Bit 7~6 Unimplemented, read as "0"

Bit 5~0 **D5~D0**: Data EEPROM Address
Data EEPROM address bit 5 ~ bit 0

EED Register

Bit	7	6	5	4	3	2	1	0
Name	D7	D6	D5	D4	D3	D2	D1	D0
R/W	R/W	R/W	R/W	R/W	R/W	R/W	R/W	R/W
POR	0	0	0	0	0	0	0	0

Bit 7~0 **D7~D0**: Data EEPROM Data
 Data EEPROM data bit 7 ~ bit 0

EEC Register

Bit	7	6	5	4	3	2	1	0
Name	—	—	—	—	WREN	WR	RDEN	RD
R/W	—	—	—	—	R/W	R/W	R/W	R/W
POR	—	—	—	—	0	0	0	0

Bit 7~4 Unimplemented, read as "0"

Bit 3 **WREN**: Data EEPROM Write Enable
 0: Disable
 1: Enable

This is the Data EEPROM Write Enable Bit which must be set high before Data EEPROM write operations are carried out. Clearing this bit to zero will inhibit Data EEPROM write operations.

Bit 2 **WR**: EEPROM Write Control
 0: Write cycle has finished
 1: Activate a write cycle

This is the Data EEPROM Write Control Bit and when set high by the application program will activate a write cycle. This bit will be automatically reset to zero by the hardware after the write cycle has finished. Setting this bit high will have no effect if the WREN has not first been set high.

Bit 1 **RDEN**: Data EEPROM Read Enable
 0: Disable
 1: Enable

This is the Data EEPROM Read Enable Bit which must be set high before Data EEPROM read operations are carried out. Clearing this bit to zero will inhibit Data EEPROM read operations.

Bit 0 **RD**: EEPROM Read Control
 0: Read cycle has finished
 1: Activate a read cycle

This is the Data EEPROM Read Control Bit and when set high by the application program will activate a read cycle. This bit will be automatically reset to zero by the hardware after the read cycle has finished. Setting this bit high will have no effect if the RDEN bit has not first been set high.

Note: The WREN, WR, RDEN and RD cannot be set high at the same time in one instruction. The WR and RD cannot be set high at the same time.

Reading Data from the EEPROM

To read data from the EEPROM, the read enable bit, RDEN, in the EEC register must first be set high to enable the read function. The EEPROM address of the data to be read must then be placed in the EEA register. If the RD bit in the EEC register is now set high, a read cycle will be initiated. Setting the RD bit high will not initiate a read operation if the RDEN bit has not been set. When the read cycle terminates, the RD bit will be automatically cleared to zero, after which the data can be read from the EED register. The data will remain in the EED register until another read or write operation is executed. The application program can poll the RD bit to determine when the data is valid for reading.

Writing Data to the EEPROM

The EEPROM address of the data to be written must first be placed in the EEA register and the data placed in the EED register. To write data to the EEPROM, the write enable bit, WREN, in the EEC register must first be set high to enable the write function. After this, the WR bit in the EEC register must be immediately set high to initiate a write cycle. These two instructions must be executed consecutively. The global interrupt bit EMI should also first be cleared before implementing any write operations, and then set again after the write cycle has started. Note that setting the WR bit high will not initiate a write cycle if the WREN bit has not been set. As the EEPROM write cycle is controlled using an internal timer whose operation is asynchronous to microcontroller system clock, a certain time will elapse before the data will have been written into the EEPROM. Detecting when the write cycle has finished can be implemented either by polling the WR bit in the EEC register or by using the EEPROM interrupt. When the write cycle terminates, the WR bit will be automatically cleared to zero by the microcontroller, informing the user that the data has been written to the EEPROM. The application program can therefore poll the WR bit to determine when the write cycle has ended.

Write Protection

Protection against inadvertent write operation is provided in several ways. After the device is powered-on the Write Enable bit in the control register will be cleared preventing any write operations. Also at power-on the Memory Pointer high byte register, MP1H or MP2H, will be reset to zero, which means that Data Memory Sector 0 will be selected. As the EEPROM control register is located in Sector 1, this adds a further measure of protection against spurious write operations. During normal program operation, ensuring that the Write Enable bit in the control register is cleared will safeguard against incorrect write operations.

EEPROM Interrupt

The EEPROM write interrupt is generated when an EEPROM write cycle has ended. The EEPROM interrupt must first be enabled by setting the DEE bit in the relevant interrupt register. However as the EEPROM is contained within a Multi-function Interrupt, the associated multi-function interrupt enable bit must also be set. When an EEPROM write cycle ends, the DEF request flag and its associated multi-function interrupt request flag will both be set. If the global, EEPROM and Multi-function interrupts are enabled and the stack is not full, a jump to the associated Multi-function Interrupt vector will take place. When the interrupt is serviced only the Multi-function interrupt flag will be automatically reset, the EEPROM interrupt flag must be manually reset by the application program. More details can be obtained in the Interrupt section.

Programming Considerations

Care must be taken that data is not inadvertently written to the EEPROM. Protection can be enhanced by ensuring that the Write Enable bit is normally cleared to zero when not writing. Also the Memory Pointer high byte register, MP1H or MP2H, could be normally cleared to zero as this would inhibit access to Sector 1 where the EEPROM control register exist. Although certainly not necessary, consideration might be given in the application program to the checking of the validity of new write data by a simple read back process.

When writing data the WR bit must be set high immediately after the WREN bit has been set high, to ensure the write cycle executes correctly. The global interrupt bit EMI should also be cleared before a write cycle is executed and then re-enabled after the write cycle starts. Note that the device should not enter the IDLE or SLEEP mode until the EEPROM read or write operation is totally complete. Otherwise, the EEPROM read or write operation will fail.

Programming Examples

• Reading data from the EEPROM – polling method

```
MOV A, EEPROM_ADRES      ; user defined address
MOV EEA, A
MOV A, 040H              ; setup memory pointer MP1L
MOV MP1L, A              ; MP1L points to EEC register
MOV A, 01H               ; setup memory pointer MP1H
MOV MP1H, A
SET IAR1.1               ; set RDEN bit, enable read operations
SET IAR1.0               ; start Read Cycle - set RD bit
BACK:
SZ IAR1.0                ; check for read cycle end
JMP BACK
CLR IAR1                  ; disable EEPROM read/write
CLR MP1H
MOV A, EED                ; move read data to register
MOV READ_DATA, A
```

• Writing Data to the EEPROM – polling method

```
MOV A, EEPROM_ADRES      ; user defined address
MOV EEA, A
MOV A, EEPROM_DATA       ; user defined data
MOV EED, A
MOV A, 040H              ; setup memory pointer MP1L
MOV MP1L, A              ; MP1L points to EEC register
MOV A, 01H               ; setup memory pointer MP1H
MOV MP1H, A
CLR EMI
SET IAR1.3               ; set WREN bit, enable write operations
SET IAR1.2               ; start Write Cycle - set WR bit - executed immediately
                        ; after set WREN bit

SET EMI
BACK:
SZ IAR1.2                ; check for write cycle end
JMP BACK
CLR IAR1                  ; disable EEPROM read/write
CLR MP1H
```

Oscillators

Various oscillator options offer the user a wide range of functions according to their various application requirements. The flexible features of the oscillator functions ensure that the best optimisation can be achieved in terms of speed and power saving. Oscillator selections and operation are selected through configuration options and relevant control registers.

Oscillator Overview

In addition to being the source of the main system clock the oscillators also provide clock sources for the Watchdog Timer and Time Base Interrupts. External oscillators requiring some external components as well as fully integrated internal oscillators, requiring no external components, are provided to form a wide range of both fast and slow system oscillators. The higher frequency oscillators provide higher performance but carry with it the disadvantage of higher power requirements, while the opposite is of course true for the lower frequency oscillators. With the capability of dynamically switching between fast and slow system clock, the device has the flexibility to optimize the performance/power ratio, a feature especially important in power sensitive portable applications.

Type	Name	Freq.	Pins
External Crystal	HXT	400kHz~16MHz	OSC1/OSC2
Internal High Speed RC	HIRC	8MHz	—
External Low Speed Crystal	LXT	32.768kHz	XT1/XT2
Internal Low Speed RC	LIRC	32kHz	—

Oscillator Types

System Clock Configurations

There are four methods of generating the system clock, two high speed oscillators and two low speed oscillators. The high speed oscillators are the external crystal/ceramic oscillator and the internal 8MHz RC oscillator. The two low speed oscillators are the internal 32kHz RC oscillator and the external 32.768kHz crystal oscillator. Selecting whether the low or high speed oscillator is used as the system oscillator is implemented using the HLCLK bit and CKS2 ~ CKS0 bits in the SMOD register and as the system clock can be dynamically selected. Note that two oscillator selections must be made namely one high speed and one low speed system oscillators. It is not possible to choose a no-oscillator selection for either the high or low speed oscillator.

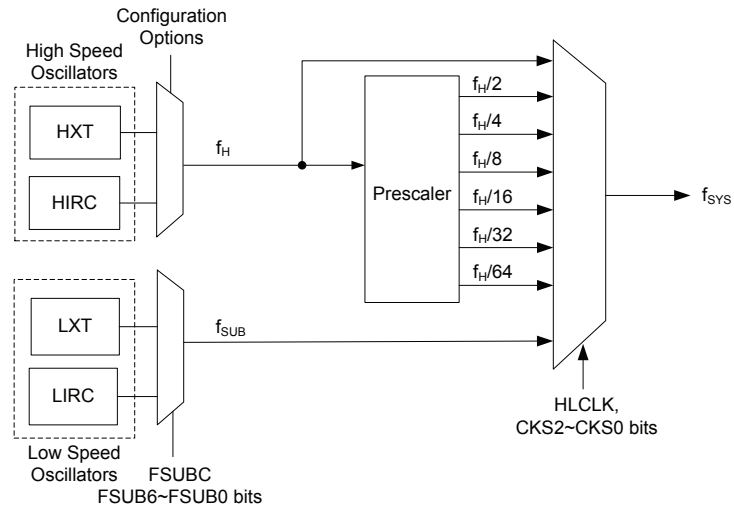

System Clock Configurations

External High Speed Crystal Oscillator – HXT

The simple connection of a crystal across OSC1 and OSC2 will create the necessary phase shift and feedback for oscillation. However, for some crystals and most resonator types, to ensure oscillation and accurate frequency generation, it is necessary to add two small value external capacitors, C1 and C2. The exact values of C1 and C2 should be selected in consultation with the crystal or resonator manufacturer’s specification. An additional configuration option must be setup to configure the device according to whether the oscillator frequency is high, defined as equal to or above 1MHz, or low, which is defined as below 1MHz.

For oscillator stability and to minimise the effects of noise and crosstalk, it is important to ensure that the crystal and any associated resistors and capacitors along with interconnecting lines are all located as close to the MCU as possible.

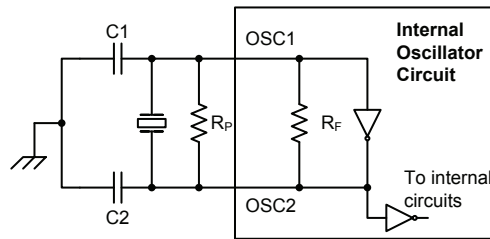

- Note: 1. R_p is normally not required. C1 and C2 are required.
 2. Although not shown OSC1/OSC2 pins have a parasitic capacitance of around 7pF.

Crystal/Resonator Oscillator – HXT

HXT Oscillator C1 and C2 Values		
Crystal Frequency	C1	C2
12MHz	0 pF	0 pF
8MHz	0 pF	0 pF
4MHz	0 pF	0 pF
1MHz	100 pF	100 pF
455kHz ^(Note 2)	100 pF	100 pF

Note: 1. C1 and C2 values are for guidance only.
 2. HXT mode configuration option: 455kHz.

Crystal Recommended Capacitor Values

Internal RC Oscillator – HIRC

The internal RC oscillator is a fully integrated system oscillator requiring no external components. The internal RC oscillator has a fixed frequency of 8MHz. Device trimming during the manufacturing process and the inclusion of internal frequency compensation circuits are used to ensure that the influence of the power supply voltage, temperature and process variations on the oscillation frequency are minimised. Note that if this internal system clock option is selected, as it requires no external pins for its operation, I/O pins are free for use as normal I/O pins.

External 32.768 kHz Crystal Oscillator – LXT

The external 32.768 kHz crystal system oscillator is one of the low frequency oscillator choices, which is selected via the FSUBC register. This clock source has a fixed frequency of 32.768 kHz and requires a 32.768 kHz crystal to be connected between pins XT1 and XT2. The external resistor and capacitor components connected to the 32.768 kHz crystal are necessary to provide oscillation. For applications where precise frequencies are essential, these components may be required to provide frequency compensation due to different crystal manufacturing tolerances. During power-up there is a time delay associated with the LXT oscillator waiting for it to start up.

When the microcontroller enters the SLEEP or IDLE Mode, the system clock is switched off to stop microcontroller activity and to conserve power. However, in many microcontroller applications it may be necessary to keep the internal timers operational even when the microcontroller is in the SLEEP or IDLE Mode. To do this, another clock, independent of the system clock, must be provided.

However, for some crystals, to ensure oscillation and accurate frequency generation, it is necessary to add two small value external capacitors, C1 and C2. The exact values of C1 and C2 should be selected in consultation with the crystal or resonator manufacturer’s specification. The external parallel feedback resistor, R_p, is required.

The FSUBC register determines if the XT1/XT2 pins are used for the LXT oscillator or as I/O or other pin-shared functional pins.

- If the LXT oscillator is not used for any clock source, the XT1/XT2 pins can be used as normal I/O or other pin-shared functional pins.
- If the LXT oscillator is used for any clock source, the 32.768 kHz crystal should be connected to the XT1/XT2 pins.

For oscillator stability and to minimise the effects of noise and crosstalk, it is important to ensure that the crystal and any associated resistors and capacitors along with interconnecting lines are all located as close to the MCU as possible.

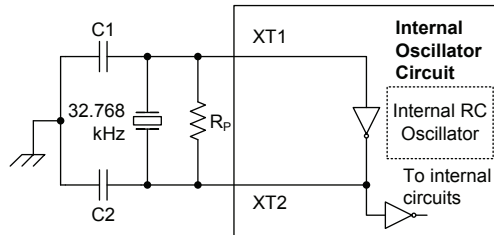

- Note: 1. R_p, C1 and C2 are required.
2. Although not shown XT1/XT2 pins have a parasitic capacitance of around 7pF.

External LXT Oscillator

LXT Oscillator C1 and C2 Values		
Crystal Frequency	C1	C2
32.768kHz	10 pF	10 pF

Note: 1. C1 and C2 values are for guidance only.
2. R_p=5M~10MΩ is recommended.

32.768kHz Crystal Recommended Capacitor Values

LXT Oscillator Low Power Function

The LXT oscillator can function in one of two modes, the Quick Start Mode and the Low Power Mode. The mode selection is executed using the LXTLP bit in the FSUBC register.

- **FSUBC Register**

Bit	7	6	5	4	3	2	1	0
Name	LXTLP	FSUB6	FSUB5	FSUB4	FSUB3	FSUB2	FSUB1	FSUB0
R/W	R/W	R/W	R/W	R/W	R/W	R/W	R/W	R/W
POR	0	0	1	0	1	0	1	0

Bit 7 **LXTLP**: LXT Low Power Control
 0: Quick Start Mode
 1: Low Power Mode

Bit 6~0 **FSUB6~FSUB0**: f_{SUB} clock source selection
 0101010: LIRC
 1010101: LXT
 Other: MCU reset

After power on, the LXTLP bit will be automatically cleared to zero ensuring that the LXT oscillator is in the Quick Start operating mode. In the Quick Start Mode the LXT oscillator will power up and stabilise quickly. However, after the LXT oscillator has fully powered up it can be placed into the Low-power mode by setting the LXTLP bit high. The oscillator will continue to run but with reduced current consumption, as the higher current consumption is only required during the LXT oscillator start-up. In power sensitive applications, such as battery applications, where power consumption must be kept to a minimum, it is therefore recommended that the application program sets the LXTLP bit high about 2 seconds after power-on.

It should be noted that, no matter what condition the LXTLP bit is set to, the LXT oscillator will always function normally, the only difference is that it will take more time to start up if in the Low-power mode.

Internal 32kHz Oscillator – LIRC

The internal 32kHz system oscillator is one of the low frequency oscillator choices, which is selected via the FSUBC register. It is a fully integrated RC oscillator with a typical frequency of 32kHz at 5V, requiring no external components for its implementation. Device trimming during the manufacturing process and the inclusion of internal frequency compensation circuits are used to ensure that the influence of the power supply voltage, temperature and process variations on the oscillation frequency are minimised. As a result, at a power supply of 5V and at a temperature of 25°C degrees, the fixed oscillation frequency of 32kHz will have a tolerance within 10%.

Operating Modes and System Clocks

Present day applications require that their microcontrollers have high performance but often still demand that they consume as little power as possible, conflicting requirements that are especially true in battery powered portable applications. The fast clocks required for high performance will by their nature increase current consumption and of course vice versa, lower speed clocks reduce current consumption. As both high and low speed clock sources are provided the means to switch between them dynamically, the user can optimise the operation of their microcontroller to achieve the best performance/power ratio.

System Clocks

The device has different clock sources for both the CPU and peripheral function operation. By providing the user with a wide range of clock selections using configuration options and register programming, a clock system can be configured to obtain maximum application performance.

The main system clock, can come from either a high frequency, f_H , or low frequency, f_{SUB} , source, and is selected using the the HLCLK bit and CKS2~CKS0 bits in the SMOD register. The high speed system clock is sourced from an HXT or HIRC oscillator. The low speed system clock source can be sourced from the internal clock f_{SUB} . If f_{SUB} is selected then it can be sourced by either the LXT or LIRC oscillator, selected via configuring the FSUB6~FSUB0 bits in the FSUBC register. The other choice, which is a divided version of the high speed system oscillator has a range of $f_H/2 \sim f_H/64$.

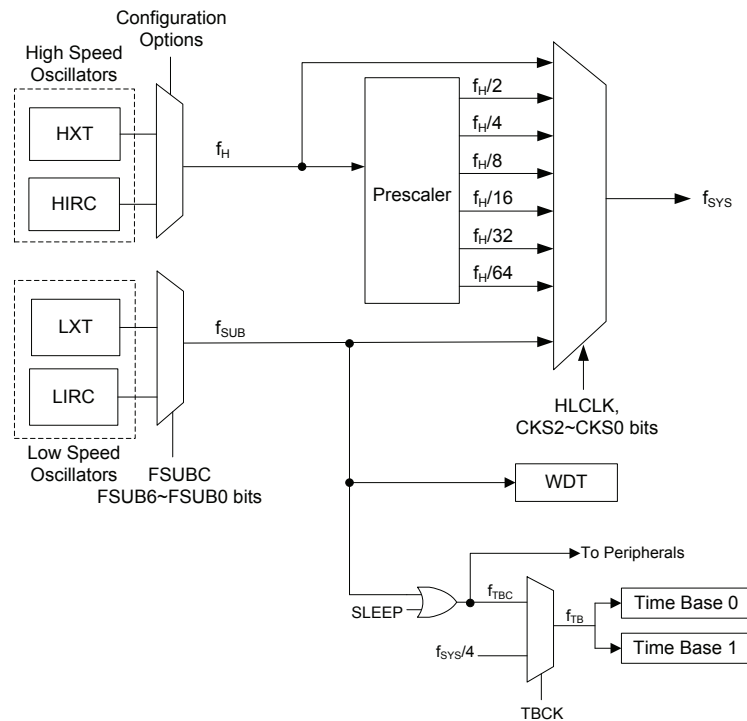

Device Clock Configurations

Note: When the system clock source f_{SYS} is switched to f_{SUB} from f_H , the high speed oscillation will stop to conserve the power. Thus there is no $f_H \sim f_H/64$ for peripheral circuit to use.

System Operation Modes

There are six different modes of operation for the microcontroller, each one with its own special characteristics and which can be chosen according to the specific performance and power requirements of the application. There are two modes allowing normal operation of the microcontroller, the NORMAL Mode and SLOW Mode. The remaining four modes, the SLEEP0, SLEEP1, IDLE0 and IDLE1 Mode are used when the microcontroller CPU is switched off to conserve power.

Operating Mode	Description			
	CPU	f _{sys}	f _{sub}	f _{tbc}
NORMAL Mode	On	f _H ~f _H /64	On	On
SLOW Mode	On	f _{sub}	On	On
IDLE0 Mode	Off	Off	On	On
IDLE1 Mode	Off	On	On	On
SLEEP0 Mode	Off	Off	Off	Off
SLEEP1 Mode	Off	Off	On	Off

NORMAL Mode

As the name suggests this is one of the main operating modes where the microcontroller has all of its functions operational and where the system clock is provided by one of the high speed oscillators. This mode operates allowing the microcontroller to operate normally with a clock source will come from one of the high speed oscillators, either the HXT or HIRC oscillator. The high speed oscillator will however first be divided by a ratio ranging from 1 to 64, the actual ratio being selected by the CKS2~CKS0 and HLCLK bits in the SMOD register. Although a high speed oscillator is used, running the microcontroller at a divided clock ratio reduces the operating current.

SLOW Mode

This is also a mode where the microcontroller operates normally although now with a slower speed clock source. The clock source used will be from one of the low speed oscillators, either the LXT or the LIRC. Running the microcontroller in this mode allows it to run with much lower operating currents. In the SLOW Mode, the f_H is off.

SLEEP0 Mode

The SLEEP0 Mode is entered when an HALT instruction is executed and when the IDLEN bit in the SMOD register is low. In the SLEEP0 mode the CPU will be stopped, and the f_{sub} clock will be stopped too, and the Watchdog Timer function is disabled. In this mode, the LVDEN must be set to "0". If the LVDEN is set to "1", it won't enter SLEEP0 Mode.

SLEEP1 Mode

The SLEEP1 Mode is entered when an HALT instruction is executed and when the IDLEN bit in the SMOD register is low. In the SLEEP1 mode the CPU will be stopped. However the f_{sub} clock will continue to operate if the LVDEN is "1" or the Watchdog Timer function is enabled.

IDLE0 Mode

The IDLE0 Mode is entered when a HALT instruction is executed and when the IDLEN bit in the SMOD register is high and the FSYSON bit in the CTRL register is low. In the IDLE0 Mode the system oscillator will be inhibited from driving the CPU, the system oscillator will be stopped, the low frequency clock f_{sub} will be on.

IDLE1 Mode

The IDLE1 Mode is entered when a HALT instruction is executed and when the IDLEN bit in the SMOD register is high and the FSYSON bit in the CTRL register is high. In the IDLE1 Mode the system oscillator will be inhibited from driving the CPU, the system oscillator will continue to run, and this system oscillator may be high speed or low speed system oscillator. In the IDLE1 Mode the low frequency clock f_{SUB} will be on.

Note: If LVDEN=1 and the SLEEP or IDLE mode is entered, the LVD and bandgap functions will not be disabled, and the f_{SUB} clock will be forced to be enabled. In SLEEP mode, other peripheral will disable except WDT, LVD if enabled in SLEEP1.

Control Registers

A single register, SMOD, is used for overall control of the internal clocks within the device.

SMOD Register

Bit	7	6	5	4	3	2	1	0
Name	CKS2	CKS1	CKS0	—	LTO	HTO	IDLEN	HLCLK
R/W	R/W	R/W	R/W	—	R	R	R/W	R/W
POR	0	0	0	—	0	0	1	1

Bit 7~5 **CKS2~CKS0**: The System Clock Selection when HLCLK is "0"

- 000: f_{SUB} (f_{LXT} or f_{LIRC})
- 001: f_{SUB} (f_{LXT} or f_{LIRC})
- 010: $f_H/64$
- 011: $f_H/32$
- 100: $f_H/16$
- 101: $f_H/8$
- 110: $f_H/4$
- 111: $f_H/2$

These three bits are used to select which clock is used as the system clock source. In addition to the system clock source, which can be either the LXT or LIRC, a divided version of the high speed system oscillator can also be chosen as the system clock source.

Bit 4 Unimplemented, read as 0.

Bit 3 **LTO**: Low speed system oscillator ready flag

- 0: Not ready
- 1: Ready

This is the low speed system oscillator ready flag which indicates when the low speed system oscillator is stable after power on reset or a wake-up has occurred. The flag will be low when in the SLEEP0 Mode but after a wake-up has occurred, the flag will change to a high level after 1024 clock cycles if the LXT oscillator is used and 1~2 clock cycles if the LIRC oscillator is used.

Bit 2 **HTO**: High speed system oscillator ready flag

- 0: Not ready
- 1: Ready

This is the high speed system oscillator ready flag which indicates when the high speed system oscillator is stable. This flag is cleared to "0" by hardware when the device is powered on and then changes to a high level after the high speed system oscillator is stable.

Therefore this flag will always be read as "1" by the application program after device power-on. The flag will be low when in the SLEEP or IDLE0 Mode but after a wake-up has occurred, the flag will change to a high level after a certain time if the HIRC or HXT oscillator is used.

- Bit 1 **IDLEN**: IDLE Mode control
 0: Disable
 1: Enable
 This is the IDLE Mode Control bit and determines what happens when the HALT instruction is executed. If this bit is high, when a HALT instruction is executed the device will enter the IDLE Mode. In the IDLE1 Mode the CPU will stop running but the system clock will continue to keep the peripheral functions operational, if FSYSON bit is high. If FSYSON bit is low, the CPU and the system clock will all stop in IDLE0 mode. If the bit is low the device will enter the SLEEP Mode when a HALT instruction is executed.
- Bit 0 **HLCLK**: System clock selection
 0: $f_H/2 \sim f_H/64$ or f_{SUB}
 1: f_H
 This bit is used to select if the f_H clock or the $f_H/2 \sim f_H/64$ or f_{SUB} clock is used as the system clock. When the bit is high the f_H clock will be selected and if low the $f_H/2 \sim f_H/64$ or f_{SUB} clock will be selected. When system clock switches from the f_H clock to the f_{SUB} clock and the f_H clock will be automatically switched off to conserve power.

CTRL Register

Bit	7	6	5	4	3	2	1	0
Name	FSYSON	—	—	—	FSUBF	LVRF	LRF	WRF
R/W	R/W	—	—	—	R/W	R/W	R/W	R/W
POR	0	—	—	—	0	x	0	0

"x" unknown

- Bit 7 **FSYSON**: f_{SYS} Control in IDLE Mode
 0: Disable
 1: Enable
- Bit 6~4 Unimplemented, read as "0"
- Bit 3 **FSUBF**: FSUBC Control register software reset flag
 0: Not occur
 1: Occurred
 This bit is set to 1 if the FSUB6~FSUB0 bits in the FSUBC register contains any non-defined values. This bit can only be cleared to 0 by the application program.
- Bit 2 **LVRF**: LVR function reset flag
 Described elsewhere
- Bit 1 **LRF**: LVR Control register software reset flag
 Described elsewhere
- Bit 0 **WRF**: WDT Control register software reset flag
 Described elsewhere

Operating Mode Switching

The device can switch between operating modes dynamically allowing the user to select the best performance/power ratio for the present task in hand. In this way microcontroller operations that do not require high performance can be executed using slower clocks thus requiring less operating current and prolonging battery life in portable applications.

In simple terms, Mode Switching between the NORMAL Mode and SLOW Mode is executed using the HLCLK bit and CKS2~CKS0 bits in the SMOD register while Mode Switching from the NORMAL/SLOW Modes to the SLEEP/IDLE Modes is executed via the HALT instruction. When an HALT instruction is executed, whether the device enters the IDLE Mode or the SLEEP Mode is determined by the condition of the IDLEN bit in the SMOD register and FSYSON bit in the CTRL register.

When the HLCLK bit switches to a low level, which implies that clock source is switched from the high speed clock source, f_H , to the clock source, $f_H/2 \sim f_H/64$ or f_{SUB} . If the clock is from the f_{SUB} , the high speed clock source will stop running to conserve power. When this happens it must be noted that the $f_H/16$ and $f_H/64$ internal clock sources will also stop running, which may affect the operation of other internal functions such as the TMs. The accompanying flowchart shows what happens when the device moves between the various operating modes.

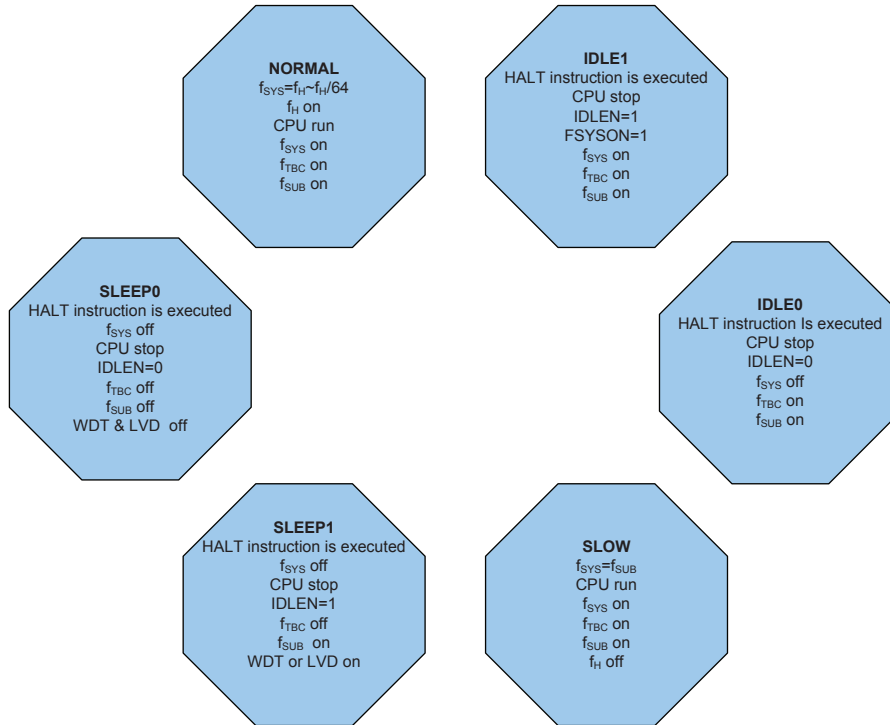

NORMAL Mode to SLOW Mode Switching

When running in the NORMAL Mode, which uses the high speed system oscillator, and therefore consumes more power, the system clock can switch to run in the SLOW Mode by set the HLCLK bit to "0" and set the CKS2~CKS0 bits to "000" or "001" in the SMOD register. This will then use the low speed system oscillator which will consume less power. Users may decide to do this for certain operations which do not require high performance and can subsequently reduce power consumption. The SLOW Mode is sourced from the LXT or LIRC oscillator and therefore requires this oscillator to be stable before full mode switching occurs.

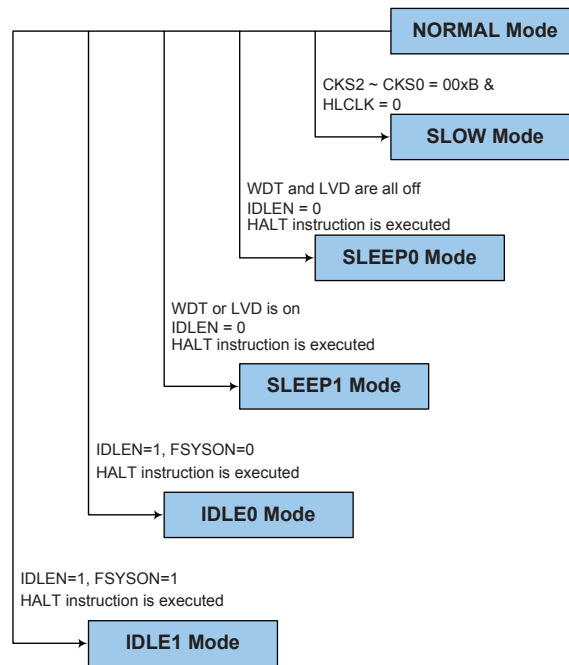

SLOW Mode to NORMAL Mode Switching

In SLOW Mode the system uses either the LXT or LIRC low speed system oscillator. To switch back to the NORMAL Mode, where the high speed system oscillator is used, the HLCLK bit should be set to "1" or HLCLK bit is "0", but CKS2~CKS0 is set to "010", "011", "100", "101", "110" or "111". As a certain amount of time will be required for the high frequency clock to stabilise, the status of the HTO bit is checked. The amount of time required for high speed system oscillator stabilization depends upon which high speed system oscillator type is used.

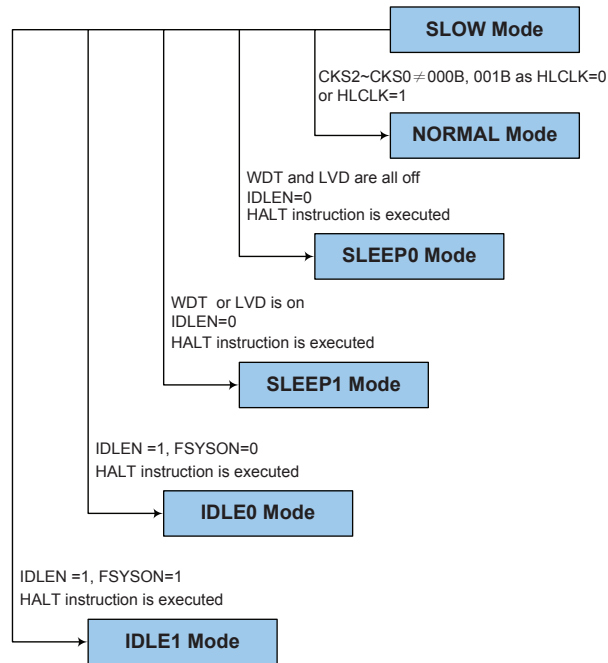

Entering the SLEEP0 Mode

There is only one way for the device to enter the SLEEP0 Mode and that is to execute the "HALT" instruction in the application program with the IDLEN bit in SMOD register equal to "0" and the WDT and LVD are both off. When this instruction is executed under the conditions described above, the following will occur:

- The system clock, WDT clock and Time Base clock will be stopped and the application program will stop at the "HALT" instruction.
- The Data Memory contents and registers will maintain their present condition.
- The WDT will be cleared and stopped.
- The I/O ports will maintain their present conditions.
- In the status register, the Power Down flag, PDF, will be set and the Watchdog time-out flag, TO, will be cleared.

Entering the SLEEP1 Mode

There is only one way for the device to enter the SLEEP1 Mode and that is to execute the "HALT" instruction in the application program with the IDLEN bit in SMOD register equal to "0" and the WDT or LVD is on. When this instruction is executed under the conditions described above, the following will occur:

- The system clock and Time Base clock will be stopped and the application program will stop at the "HALT" instruction, but the WDT or LVD will remain with the clock source coming from the f_{SUB} clock.
- The Data Memory contents and registers will maintain their present condition.
- The WDT will be cleared and resume counting if the WDT is enabled. If the WDT function is disabled, the WDT will be cleared and stopped.
- The I/O ports will maintain their present conditions.
- In the status register, the Power Down flag, PDF, will be set and the Watchdog time-out flag, TO, will be cleared.

Entering the IDLE0 Mode

There is only one way for the device to enter the IDLE0 Mode and that is to execute the "HALT" instruction in the application program with the IDLEN bit in SMOD register equal to "1" and the FSYSON bit in CTRL register equal to "0". When this instruction is executed under the conditions described above, the following will occur:

- The system clock will be stopped and the application program will stop at the "HALT" instruction, but the Time Base clock f_{TBC} and f_{SUB} clock will be on.
- The Data Memory contents and registers will maintain their present condition.
- The WDT will be cleared and resume counting if the WDT is enabled. If the WDT function is disabled, the WDT will be cleared and stopped.
- The I/O ports will maintain their present conditions.
- In the status register, the Power Down flag, PDF, will be set and the Watchdog time-out flag, TO, will be cleared.

Entering the IDLE1 Mode

There is only one way for the device to enter the IDLE1 Mode and that is to execute the "HALT" instruction in the application program with the IDLEN bit in SMOD register equal to "1" and the FSYSON bit in CTRL register equal to "1". When this instruction is executed under the conditions described above, the following will occur:

- The system clock, Time Base clock f_{TBC} and f_{SUB} clock will be on and the application program will stop at the "HALT" instruction.
- The Data Memory contents and registers will maintain their present condition.
- The WDT will be cleared and resume counting if the WDT is enabled. If the WDT function is disabled, the WDT will be cleared and stopped.
- The I/O ports will maintain their present conditions.
- In the status register, the Power Down flag, PDF, will be set and the Watchdog time-out flag, TO, will be cleared.

Standby Current Considerations

As the main reason for entering the SLEEP or IDLE Mode is to keep the current consumption of the device to as low a value as possible, perhaps only in the order of several micro-amps except in the IDLE1 Mode, there are other considerations which must also be taken into account by the circuit designer if the power consumption is to be minimised. Special attention must be made to the I/O pins on the device. All high-impedance input pins must be connected to either a fixed high or low level as any floating input pins could create internal oscillations and result in increased current consumption. This also applies to devices which have different package types, as there may be unbonded pins. These must either be setup as outputs or if setup as inputs must have pull-high resistors connected.

Care must also be taken with the loads, which are connected to I/O pins, which are setup as outputs. These should be placed in a condition in which minimum current is drawn or connected only to external circuits that do not draw current, such as other CMOS inputs. Also note that additional standby current will also be required if the LXT or LIRC oscillator has enabled.

In the IDLE1 Mode the system clock is on, if the peripheral function clock source is derived from the high speed oscillator, the additional standby current will also be perhaps in the order of several hundred micro-amps.

Wake-up

After the system enters the SLEEP or IDLE Mode, it can be woken up from one of various sources listed as follows:

- An external falling edge on Port A
- A system interrupt
- A WDT overflow

If the device is woken up by a WDT overflow, a Watchdog Timer reset will be initiated. Although both of these wake-up methods will initiate a reset operation, the actual source of the wake-up can be determined by examining the TO and PDF flags. The PDF flag is cleared by a system power-up or executing the clear Watchdog Timer instructions and is set when executing the "HALT" instruction. The TO flag is set if a WDT time-out occurs, and causes a wake-up that only resets the Program Counter and Stack Pointer, the other flags remain in their original status.

Each pin on Port A can be setup using the PAWU register to permit a negative transition on the pin to wake up the system. When a Port A pin wake-up occurs, the program will resume execution at the instruction following the "HALT" instruction. If the system is woken up by an interrupt, then two possible situations may occur. The first is where the related interrupt is disabled or the interrupt is enabled but the stack is full, in which case the program will resume execution at the instruction following the "HALT" instruction. In this situation, the interrupt which woke up the device will not be immediately serviced, but will rather be serviced later when the related interrupt is finally enabled or when a stack level becomes free. The other situation is where the related interrupt is enabled and the stack is not full, in which case the regular interrupt response takes place. If an interrupt request flag is set high before entering the SLEEP or IDLE Mode, the wake-up function of the related interrupt will be disabled.

Watchdog Timer

The Watchdog Timer is provided to prevent program malfunctions or sequences from jumping to unknown locations, due to certain uncontrollable external events such as electrical noise.

Watchdog Timer Clock Source

The Watchdog Timer clock source is provided by the internal clock, f_{SUB} , the f_{SUB} clock is sourced from LIRC or LXT oscillator selected by the FSUBC register. The Watchdog Timer source clock is then subdivided by a ratio of 2^8 to 2^{18} to give longer timeouts, the actual value being chosen using the WS2~WS0 bits in the WDTC register. The LIRC internal oscillator has an approximate period of 32kHz at a supply voltage of 5V. However, it should be noted that this specified internal clock period can vary with V_{DD} , temperature and process variations. The LXT oscillator is supplied by an external 32.768kHz crystal.

Watchdog Timer Control Register

A single register, WDTC, controls the required timeout period as well as the enable/disable and reset MCU operation.

WDTC Register

Bit	7	6	5	4	3	2	1	0
Name	WE4	WE3	WE2	WE1	WE0	WS2	WS1	WS0
R/W	R/W	R/W	R/W	R/W	R/W	R/W	R/W	R/W
POR	0	1	0	1	0	0	1	1

Bit 7~3 **WE4~WE0**: WDT Function Software Control

10101: Disable
 01010: Enable
 Others: Reset MCU

When these bits are changed by the environmental noise or software setting to reset the microcontroller, the reset operation will be activated after a delay time, t_{SRESET} , and the WRF bit in the CTRL register will be set high.

Bit 2~0 **WS2~WS0**: WDT Time-out Period Selection

000: $2^8/f_{SUB}$
 001: $2^{10}/f_{SUB}$
 010: $2^{12}/f_{SUB}$
 011: $2^{14}/f_{SUB}$
 100: $2^{15}/f_{SUB}$
 101: $2^{16}/f_{SUB}$
 110: $2^{17}/f_{SUB}$
 111: $2^{18}/f_{SUB}$

These three bits determine the division ratio of the watchdog timer source clock, which in turn determines the time-out period.

CTRL Register

Bit	7	6	5	4	3	2	1	0
Name	FSYSON	—	—	—	FSUBF	LVRF	LRF	WRF
R/W	R/W	—	—	—	R/W	R/W	R/W	R/W
POR	0	—	—	—	0	x	0	0

"x" unknown

Bit 7 **FSYSON**: f_{SYS} Control in IDLE Mode
 Described elsewhere

Bit 6~4 Unimplemented, read as "0"

Bit 3 **FSUBF**: FSUBC Control Register Software Reset Flag
 Described elsewhere

- Bit 2 **LVRF**: LVR Function Reset Flag
 Described elsewhere
- Bit 1 **LRF**: LVR Control Register Software Reset Flag
 Described elsewhere
- Bit 0 **WRF**: WDT Control Register Software Reset Flag
 0: Not occur
 1: Occurred
 This bit is set high by the WDT Control register software reset and cleared by the application program. Note that this bit can only be cleared to zero by the application program.

Watchdog Timer Operation

The Watchdog Timer operates by providing a device reset when its timer overflows. This means that in the application program and during normal operation the user has to strategically clear the Watchdog Timer before it overflows to prevent the Watchdog Timer from executing a reset. This is done using the clear watchdog instructions. If the program malfunctions for whatever reason, jumps to an unknown location, or enters an endless loop, these clear instructions will not be executed in the correct manner, in which case the Watchdog Timer will overflow and reset the device. There are five bits, WE4~WE0, in the WDTC register to offer the enable/disable control and reset control of the Watchdog Timer. The WDT function will be disabled when the WE4~WE0 bits are set to a value of 10101B while the WDT function will be enabled if the WE4~WE0 bits are equal to 01010B. If the WE4~WE0 bits are set to any other values, other than 01010B and 10101B, it will reset the device after a delay time, t_{SRESET} . After power on these bits will have a value of 01010B.

WE4 ~ WE0 Bits	WDT Function
10101B	Disable
01010B	Enable
Any other values	Reset MCU

Watchdog Timer Enable/Disable Control

Under normal program operation, a Watchdog Timer time-out will initialise a device reset and set the status bit TO. However, if the system is in the SLEEP or IDLE Mode, when a Watchdog Timer time-out occurs, the TO bit in the status register will be set and only the Program Counter and Stack Pointer will be reset. Three methods can be adopted to clear the contents of the Watchdog Timer. The first is a WDT reset, which means a certain value except 01010B and 10101B written into the WE4~WE0 bit filed, the second is using the Watchdog Timer software clear instruction and the third is via a HALT instruction.

There is only one method of using software instruction to clear the Watchdog Timer. That is to use the single "CLR WDT" instruction to clear the WDT.

The maximum time out period is when the 2^{18} division ratio is selected. As an example, with a 32kHz LIRC oscillator as its source clock, this will give a maximum watchdog period of around 8 seconds for the 2^{18} division ratio, and a minimum timeout of 8ms for the 2^8 division ratio.

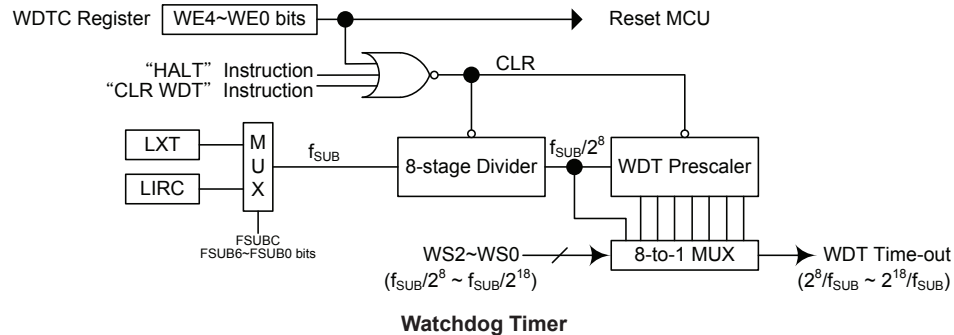

Reset and Initialisation

A reset function is a fundamental part of any microcontroller ensuring that the device can be set to some predetermined condition irrespective of outside parameters. The most important reset condition is after power is first applied to the microcontroller. In this case, internal circuitry will ensure that the microcontroller, after a short delay, will be in a well-defined state and ready to execute the first program instruction. After this power-on reset, certain important internal registers will be set to defined states before the program commences. One of these registers is the Program Counter, which will be reset to zero forcing the microcontroller to begin program execution from the lowest Program Memory address.

Another type of reset is when the Watchdog Timer overflows and resets. All types of reset operations result in different register conditions being setup. Another reset exists in the form of a Low Voltage Reset, LVR, where a full reset, is implemented in situations where the power supply voltage falls below a certain threshold.

Reset Functions

There are several ways in which a microcontroller reset can occur, through events occurring internally.

Power-on Reset

The most fundamental and unavoidable reset is the one that occurs after power is first applied to the microcontroller. As well as ensuring that the Program Memory begins execution from the first memory address, a power-on reset also ensures that certain other registers are preset to known conditions. All the I/O port and port control registers will power up in a high condition ensuring that all I/O ports will be first set to inputs.

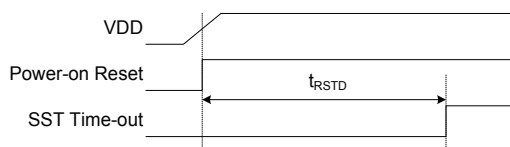

Power-On Reset Timing Chart

Low Voltage Reset – LVR

The microcontroller contains a low voltage reset circuit in order to monitor the supply voltage of the device. The LVR function is always enabled with a specific LVR voltage V_{LVR} . If the supply voltage of the device drops to within a range of $0.9V \sim V_{LVR}$ such as might occur when changing the battery, the LVR will automatically reset the device internally and the LVRF bit in the CTRL register will also be set high. For a valid LVR signal, a low supply voltage, i.e., a voltage in the range between $0.9V \sim V_{LVR}$ must exist for a time greater than that specified by t_{LVR} in the LVD/LVR Electrical Characteristics. If the low supply voltage state does not exceed this value, the LVR will ignore the low supply voltage and will not perform a reset function. The actual V_{LVR} value can be selected by the LVS7~LVS0 bits in the LVRC register. If the LVS7~LVS0 bits are changed to some certain values by the environmental noise or software setting, the LVR will reset the device after a delay time, t_{SRESET} . When this happens, the LRF bit in the CTRL register will be set high. After power on the register will have the value of 01010101B. Note that the LVR function will be automatically disabled when the device enters the power down mode.

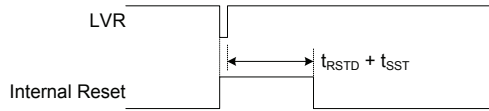

Low Voltage Reset Timing Chart

• **LVRC Register**

Bit	7	6	5	4	3	2	1	0
Name	LVS7	LVS6	LVS5	LVS4	LVS3	LVS2	LVS1	LVS0
R/W	R/W	R/W	R/W	R/W	R/W	R/W	R/W	R/W
POR	0	1	0	1	0	1	0	1

Bit 7~0 **LVS7~LVS0**: LVR Voltage Select

01010101: 2.1V
00110011: 2.55V
10011001: 3.15V
10101010: 3.8V

Other values: MCU reset – register is reset to POR value

When an actual low voltage condition occurs, as specified by one of the four defined LVR voltage values above, an MCU reset will be generated. The reset operation will be activated after the low voltage condition keeps more than a t_{LVR} time. In this situation the register contents will remain the same after such a reset occurs.

Any register value, other than the four defined LVR values above, will also result in the generation of an MCU reset. The reset operation will be activated after a delay time, t_{SRESET} . However in this situation the register contents will be reset to the POR value.

• **CTRL Register**

Bit	7	6	5	4	3	2	1	0
Name	FSYSON	—	—	—	FSUBF	LVRF	LRF	WRF
R/W	R/W	—	—	—	R/W	R/W	R/W	R/W
POR	0	—	—	—	0	x	0	0

"x" unknown

Bit 7 **FSYSON**: f_{SYS} Control in IDLE Mode

Described elsewhere

Bit 6~4 Unimplemented, read as "0"

Bit 3 **FSUBF**: FSUBC Control Register Software Reset Flag

Described elsewhere

Bit 2 **LVRF**: LVR Function Reset Flag

0: Not occur

1: Occurred

This bit is set high when a specific Low Voltage Reset situation condition occurs. This bit can only be cleared to zero by the application program.

Bit 1 **LRF**: LVR Control Register Software Reset Flag

0: Not occur

1: Occurred

This bit is set high if the LVRC register contains any non-defined LVR voltage register values. This in effect acts like a software-reset function. This bit can only be cleared to zero by the application program.

Bit 0 **WRF**: WDT Control register software reset flag

Described elsewhere

Watchdog Time-out Reset during Normal Operation

The Watchdog time-out Reset during normal operation is the same as LVR reset except that the Watchdog time-out flag TO will be set high.

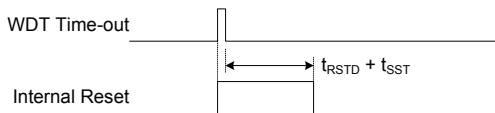

WDT Time-out Reset during Normal Operation Timing Chart

Watchdog Time-out Reset during SLEEP or IDLE Mode

The Watchdog time-out Reset during SLEEP or IDLE Mode is a little different from other kinds of reset. Most of the conditions remain unchanged except that the Program Counter and the Stack Pointer will be cleared to zero and the TO flag will be set high. Refer to the A.C. Characteristics for t_{SST} details.

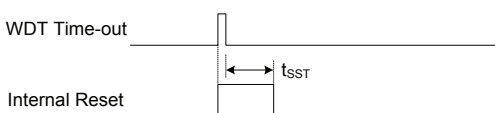

WDT Time-out Reset during SLEEP or IDLE Mode Timing Chart

Reset Initial Conditions

The different types of reset described affect the reset flags in different ways. These flags, known as PDF and TO are located in the status register and are controlled by various microcontroller operations, such as the SLEEP or IDLE Mode function or Watchdog Timer. The reset flags are shown in the table:

TO	PDF	Reset Conditions
0	0	Power-on reset
u	u	LVR reset during NORMAL or SLOW Mode operation
1	u	WDT time-out reset during NORMAL or SLOW Mode operation
1	1	WDT time-out reset during IDLE or SLEEP Mode operation

Note: "u" stands for unchanged

The following table indicates the way in which the various components of the microcontroller are affected after a power-on reset occurs.

Item	Condition after Reset
Program Counter	Reset to zero
Interrupts	All interrupts will be disabled
WDT, Time Bases	Clear after reset, WDT begins counting
Timer Modules	Timer Modules will be turned off
Input/Output Ports	I/O ports will be setup as inputs
Stack Pointer	Stack Pointer will point to the top of the stack

The different kinds of resets all affect the internal registers of the microcontroller in different ways. To ensure reliable continuation of normal program execution after a reset occurs, it is important to know what condition the microcontroller is in after a particular reset occurs. The following table describes how each type of reset affects each of the microcontroller internal registers. Note that where more than one package type exists the table will reflect the situation for the larger package type.

Register	Reset (Power On)	LVR Reset (Normal Operation)	WDT Time-out (Normal Operation)	WDT Time-out (IDLE/SLEEP)
IAR0	xxxx xxxx	uuuu uuuu	uuuu uuuu	uuuu uuuu
MP0	xxxx xxxx	uuuu uuuu	uuuu uuuu	uuuu uuuu
IAR1	xxxx xxxx	uuuu uuuu	uuuu uuuu	uuuu uuuu
MP1L	xxxx xxxx	uuuu uuuu	uuuu uuuu	uuuu uuuu
MP1H	xxxx xxxx	uuuu uuuu	uuuu uuuu	uuuu uuuu
ACC	xxxx xxxx	uuuu uuuu	uuuu uuuu	uuuu uuuu
PCL	0000 0000	0000 0000	0000 0000	0000 0000
TBLP	xxxx xxxx	uuuu uuuu	uuuu uuuu	uuuu uuuu
TBLH	xxxx xxxx	uuuu uuuu	uuuu uuuu	uuuu uuuu
TBHP	---x xxxx	---u uuuu	---u uuuu	---u uuuu
STATUS	xx00 xxxx	uuuu uuuu	uu1u uuuu	uu11 uuuu
IAR2	xxxx xxxx	uuuu uuuu	uuuu uuuu	uuuu uuuu
MP2L	xxxx xxxx	uuuu uuuu	uuuu uuuu	uuuu uuuu
MP2H	xxxx xxxx	uuuu uuuu	uuuu uuuu	uuuu uuuu
SMOD	000- 0011	000- 0011	000- 0011	uuu- uuuu
TBC	0011 - 111	0011 - 111	0011 - 111	uuuu - uuu
WDTC	0101 0011	0101 0011	0101 0011	uuuu uuuu
LVDC	--00 -000	--00 -000	--00 -000	--uu -uuu
LVRC	0101 0101	0101 0101	0101 0101	uuuu uuuu
CTRL	0--- 0x00	0--- u1uu	0--- uuuu	0--- uuuu
FSUBC	0010 1010	0010 1010	0010 1010	uuuu uuuu
INTEG	0000 0000	0000 0000	0000 0000	uuuu uuuu
INTC0	-000 0000	-000 0000	-000 0000	-uuu uuuu
INTC1	0000 0000	0000 0000	0000 0000	uuuu uuuu
INTC2	0000 0000	0000 0000	0000 0000	uuuu uuuu
MF10	--00 --00	--00 --00	--00 --00	--uu --uu
MF11	--00 --00	--00 --00	--00 --00	--uu --uu
MF12	--00 --00	--00 --00	--00 --00	--uu --uu
MF13	--00 --00	--00 --00	--00 --00	--uu --uu
PAWU	0000 0000	0000 0000	0000 0000	uuuu uuuu
PAPU	0000 0000	0000 0000	0000 0000	uuuu uuuu
PA	1111 1111	1111 1111	1111 1111	uuuu uuuu
PAC	1111 1111	1111 1111	1111 1111	uuuu uuuu
PBPU	--00 0000	--00 0000	--00 0000	--uu uuuu
PB	--11 1111	--11 1111	--11 1111	--uu uuuu
PBC	--11 1111	--11 1111	--11 1111	--uu uuuu
IOHR0	0000 0000	0000 0000	0000 0000	uuuu uuuu
IOHR1	0000 0000	0000 0000	0000 0000	uuuu uuuu
MF14	0000 0000	0000 0000	0000 0000	uuuu uuuu
ADRL	xxxx ----	xxxx ----	xxxx ----	uuuu ---- (ADRF=0)
				uuuu uuuu (ADRF=1)
ADRH	xxxx xxxx	xxxx xxxx	xxxx xxxx	uuuu uuuu (ADRF=0)
				---- uuuu (ADRF=1)
ADCRO	0110 0000	0110 0000	0110 0000	uuuu uuuu

Register	Reset (Power On)	LVR Reset (Normal Operation)	WDT Time-out (Normal Operation)	WDT Time-out (IDLE/SLEEP)
ADCR1	00-0 -000	00-0 -000	00-0 -000	uu-u -uuu
ACERL	0000 0000	0000 0000	0000 0000	uuuu uuuu
ACERH	---- --00	---- --00	---- --00	---- --uu
TM0C0	0000 0---	0000 0---	0000 0---	uuuu u---
TM0C1	0000 0000	0000 0000	0000 0000	uuuu uuuu
TM0DL	0000 0000	0000 0000	0000 0000	uuuu uuuu
TM0DH	---- --00	---- --00	---- --00	---- --uu
TM0AL	0000 0000	0000 0000	0000 0000	uuuu uuuu
TM0AH	---- --00	---- --00	---- --00	---- --uu
TM0RPL	0000 0000	0000 0000	0000 0000	uuuu uuuu
TM0RPH	---- --00	---- --00	---- --00	---- --uu
TM1C0	0000 0000	0000 0000	0000 0000	uuuu uuuu
TM1C1	0000 0000	0000 0000	0000 0000	uuuu uuuu
TM1DL	0000 0000	0000 0000	0000 0000	uuuu uuuu
TM1DH	---- --00	---- --00	---- --00	---- --uu
TM1AL	0000 0000	0000 0000	0000 0000	uuuu uuuu
TM1AH	---- --00	---- --00	---- --00	---- --uu
INTC3	---0 ---0	---0 ---0	---0 ---0	---u ---u
EEA	--00 0000	--00 0000	--00 0000	--uu uuuu
EED	0000 0000	0000 0000	0000 0000	uuuu uuuu
USR	0000 1011	0000 1011	0000 1011	uuuu uuuu
UCR1	0000 00x0	0000 00x0	0000 00x0	uuuu uuuu
UCR2	0000 0000	0000 0000	0000 0000	uuuu uuuu
BRG	xxxx xxxx	xxxx xxxx	xxxx xxxx	uuuu uuuu
TXR/RXR	xxxx xxxx	xxxx xxxx	xxxx xxxx	uuuu uuuu
TMPC	---0 0000	---0 0000	---0 0000	---u uuuu
TM2C0	0000 0000	0000 0000	0000 0000	uuuu uuuu
TM2C1	0000 0000	0000 0000	0000 0000	uuuu uuuu
TM2DL	0000 0000	0000 0000	0000 0000	uuuu uuuu
TM2DH	---- --00	---- --00	---- --00	---- --uu
TM2AL	0000 0000	0000 0000	0000 0000	uuuu uuuu
TM2AH	---- --00	---- --00	---- --00	---- --uu
TM3C0	0000 0000	0000 0000	0000 0000	uuuu uuuu
TM3C1	0000 0000	0000 0000	0000 0000	uuuu uuuu
TM3DL	0000 0000	0000 0000	0000 0000	uuuu uuuu
TM3DH	---- --00	---- --00	---- --00	---- --uu
TM3AL	0000 0000	0000 0000	0000 0000	uuuu uuuu
TM3AH	---- --00	---- --00	---- --00	---- --uu
LCDC0	xxxx -xxx	xxxx -xxx	xxxx -xxx	uuuu -uuu
LCDC1	xxx- xxxx	xxx- xxxx	xxx- xxxx	uuu- uuuu
SEGCR0	1111 1111	1111 1111	1111 1111	uuuu uuuu
SEGCR1	1111 1111	1111 1111	1111 1111	uuuu uuuu
SEGCR2	1111 1111	1111 1111	1111 1111	uuuu uuuu
SEGCR3	1111 1111	1111 1111	1111 1111	uuuu uuuu
PCPU	0000 0000	0000 0000	0000 0000	uuuu uuuu
PC	1111 1111	1111 1111	1111 1111	uuuu uuuu
PCC	1111 1111	1111 1111	1111 1111	uuuu uuuu

Register	Reset (Power On)	LVR Reset (Normal Operation)	WDT Time-out (Normal Operation)	WDT Time-out (IDLE/SLEEP)
PDPU	0000 0000	0000 0000	0000 0000	uuuu uuuu
PD	1111 1111	1111 1111	1111 1111	uuuu uuuu
PDC	1111 1111	1111 1111	1111 1111	uuuu uuuu
PEPU	0000 0000	0000 0000	0000 0000	uuuu uuuu
PE	1111 1111	1111 1111	1111 1111	uuuu uuuu
PEC	1111 1111	1111 1111	1111 1111	uuuu uuuu
PFPU	0000 ----	0000 ----	0000 ----	uuuu ----
PF	1111 ----	1111 ----	1111 ----	uuuu ----
PFC	1111 ----	1111 ----	1111 ----	uuuu ----
PGPU	0000 0000	0000 0000	0000 0000	uuuu uuuu
PG	1111 1111	1111 1111	1111 1111	uuuu uuuu
PGC	1111 1111	1111 1111	1111 1111	uuuu uuuu
SIMC0	111- 0000	111- 0000	111- 0000	uuu- uuuu
SIMC1	1000 0001	1000 0001	1000 0001	uuuu uuuu
SIMD	xxxx xxxx	xxxx xxxx	xxxx xxxx	uuuu uuuu
SIMA	0000 0000	0000 0000	0000 0000	uuuu uuuu
SIMC2	0000 0000	0000 0000	0000 0000	uuuu uuuu
SIMTOC	0000 0000	0000 0000	0000 0000	uuuu uuuu
EEC	---- 0000	---- 0000	---- 0000	---- uuuu

Note: "u" stands for unchanged
"x" stands for unknown
"-" stands for unimplemented

Input/Output Ports

The microcontrollers offer considerable flexibility on their I/O ports. With the input or output designation of every pin fully under user program control, pull-high selections for all ports and wake-up selections on certain pins, the user is provided with an I/O structure to meet the needs of a wide range of application possibilities.

The device provides bidirectional input/output lines labeled with port names PA~PG. These I/O ports are mapped to the RAM Data Memory with specific addresses as shown in the Special Purpose Data Memory table. All of these I/O ports can be used for input and output operations. For input operation, these ports are non-latching, which means the inputs must be ready at the T2 rising edge of instruction "MOV A, [m]", where m denotes the port address. For output operation, all the data is latched and remains unchanged until the output latch is rewritten.

Register Name	Bit							
	7	6	5	4	3	2	1	0
PA	PA7	PA6	PA5	PA4	PA3	PA2	PA1	PA0
PAC	PAC7	PAC5	PAC5	PAC4	PAC3	PAC2	PAC1	PAC0
PAPU	PAPU7	PAPU4	PAPU5	PAPU4	PAPU3	PAPU2	PAPU1	PAPU0
PAWU	PAWU7	PAWU6	PAWU5	PAWU4	PAWU3	PAWU2	PAWU1	PAWU0
PB	—	—	PB5	PB4	PB3	PB2	PB1	PB0
PBC	—	—	PBC5	PBC4	PBC3	PBC2	PBC1	PBC0
PBPU	—	—	PBPU5	PBPU4	PBPU3	PBPU2	PBPU1	PBPU0
PC	PC7	PC6	PC5	PC4	PC3	PC2	PC1	PC0
PCC	PCC7	PCC6	PCC5	PCC4	PCC3	PCC2	PCC1	PCC0
PCPU	PCPU7	PCPU6	PCPU5	PCPU4	PCPU3	PCPU2	PCPU1	PCPU0
PD	PD7	PD6	PD5	PD4	PD3	PD2	PD1	PD0
PDC	PDC7	PDC6	PDC5	PDC4	PDC3	PDC2	PDC1	PDC0
PDPU	PDPU7	PDPU6	PDPU5	PDPU4	PDPU3	PDPU2	PDPU1	PDPU0
PE	PE7	PE6	PE5	PE4	PE3	PE2	PE1	PE0
PEC	PEC7	PEC6	PEC5	PEC4	PEC3	PEC2	PEC1	PEC0
PEPU	PEPU7	PEPU6	PEPU5	PEPU4	PEPU3	PEPU2	PEPU1	PEPU0
PF	PF7	PF6	PF5	PF4	—	—	—	—
PFC	PFC7	PFC6	PFC5	PFC4	—	—	—	—
PFPU	PFPU7	PFPU6	PFPU5	PFPU4	—	—	—	—
PG	PG7	PG6	PG5	PG4	PG3	PG2	PG1	PG0
PGC	PGC7	PGC6	PGC5	PGC4	PGC3	PGC2	PGC1	PGC0
PGPU	PGPU7	PGPU6	PGPU5	PGPU4	PGPU3	PGPU2	PGPU1	PGPU0

"—" Unimplemented, read as "0"

I/O Logic Function Registers List

Pull-high Resistors

Many product applications require pull-high resistors for their switch inputs usually requiring the use of an external resistor. To eliminate the need for these external resistors, all I/O pins, when configured as an input have the capability of being connected to an internal pull-high resistor. These pull-high resistors are selected using registers PAPU~PGPU, and are implemented using weak PMOS transistors.

PxPU Register

Bit	7	6	5	4	3	2	1	0
Name	PxPU7	PxPU6	PxPU5	PxPU4	PxPU3	PxPU2	PxPU1	PxPU0
R/W	R/W	R/W	R/W	R/W	R/W	R/W	R/W	R/W
POR	0	0	0	0	0	0	0	0

PxPUn: I/O Port x Pin Pull-high Function Control

0: Disable

1: Enable

The PxPUn bit is used to control the pin pull-high function. Here the "x" can be A, B, C, D, E, F and G. However, the actual available bits for each I/O port may be different.

Port A Wake-up

The HALT instruction forces the microcontroller into the SLEEP or IDLE Mode which preserves power, a feature that is important for battery and other low-power applications. Various methods exist to wake-up the microcontroller, one of which is to change the logic condition on one of the Port A pins from high to low. This function is especially suitable for applications that can be woken up via external switches. Each pin on Port A can be selected individually to have this wake-up feature using the PAWU register.

PAWU Register

Bit	7	6	5	4	3	2	1	0
Name	PAWU7	PAWU6	PAWU5	PAWU4	PAWU3	PAWU2	PAWU1	PAWU0
R/W	R/W	R/W	R/W	R/W	R/W	R/W	R/W	R/W
POR	0	0	0	0	0	0	0	0

PAWUn: Port A Pin Wake-up Control

0: Disable

1: Enable

I/O Port Control Registers

Each I/O port has its own control register known as PAC~PGC, to control the input/output configuration. With this control register, each CMOS output or input can be reconfigured dynamically under software control. Each pin of the I/O ports is directly mapped to a bit in its associated port control register. For the I/O pin to function as an input, the corresponding bit of the control register must be written as a "1". This will then allow the logic state of the input pin to be directly read by instructions. When the corresponding bit of the control register is written as a "0", the I/O pin will be setup as a CMOS output. If the pin is currently setup as an output, instructions can still be used to read the output register. However, it should be noted that the program will in fact only read the status of the output data latch and not the actual logic status of the output pin.

PxC Register

Bit	7	6	5	4	3	2	1	0
Name	PxC7	PxC6	PxC5	PxC4	PxC3	PxC2	PxC1	PxC0
R/W	R/W	R/W	R/W	R/W	R/W	R/W	R/W	R/W
POR	1	1	1	1	1	1	1	1

PxCn: I/O Port x Pin Type Selection

0: Output

1: Input

The PxCn bit is used to control the pin type selection. Here the "x" can be A, B, C, D, E, F and G. However, the actual available bits for each I/O port may be different.

Pin-shared Functions

The flexibility of the microcontroller range is greatly enhanced by the use of pins that have more than one function. Limited numbers of pins can force serious design constraints on designers but by supplying pins with multi-functions, many of these difficulties can be overcome. The way in which the pin function of each pin is selected is different for each function and a priority order is established where more than one pin function is selected simultaneously.

I/O Pin Structures

The accompanying diagram illustrates the internal structures of the I/O logic function. As the exact logical construction of the I/O pin will differ from this diagram, it is supplied as a guide only to assist with the functional understanding of the logic function I/O pins. The wide range of pin-shared structures does not permit all types to be shown.

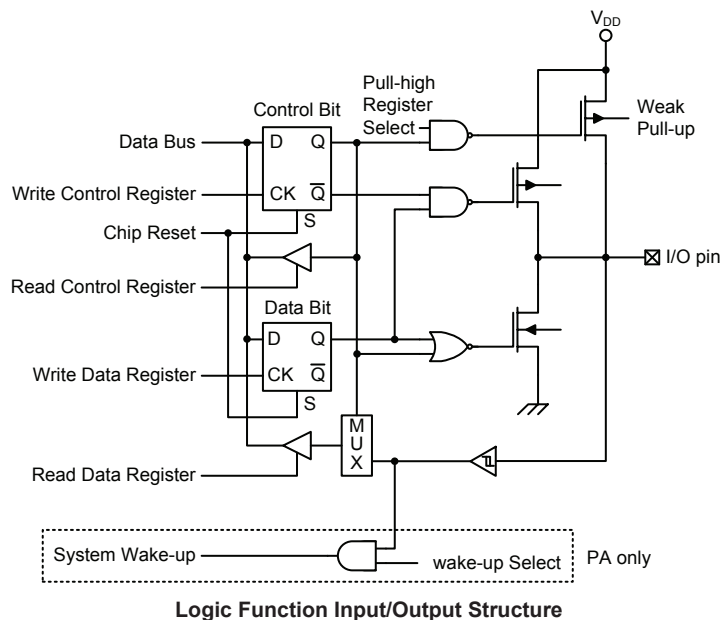

Logic Function Input/Output Structure

Programming Considerations

Within the user program, one of the things first to consider is port initialisation. After a reset, all of the I/O data and port control registers will be set to high. This means that all I/O pins will be defaulted to an input state, the level of which depends on the other connected circuitry and whether pull-high selections have been chosen. If the port control registers are then programmed to setup some pins as outputs, these output pins will have an initial high output value unless the associated port data registers are first programmed. Selecting which pins are inputs and which are outputs can be achieved byte-wide by loading the correct values into the appropriate port control register or by programming individual bits in the port control register using the "SET [m].i" and "CLR [m].i" instructions. Note that when using these bit control instructions, a read-modify-write operation takes place. The microcontroller must first read in the data on the entire port, modify it to the required new bit values and then rewrite this data back to the output ports.

Port A has the additional capability of providing wake-up functions. When the device is in the SLEEP or IDLE Mode, various methods are available to wake the device up. One of these is a high to low transition of any of the Port A pins. Single or multiple pins on Port A can be setup to have this function.

Timer Modules – TM

One of the most fundamental functions in any microcontroller devices is the ability to control and measure time. To implement time related functions the device includes several Timer Modules, generally abbreviated to the name TM. The TMs are multi-purpose timing units and serve to provide operations such as Timer/Counter, Input Capture, Compare Match Output and Single Pulse Output as well as being the functional unit for the generation of PWM signals. Each of the TMs has two interrupts. The addition of input and output pins for each TM ensures that users are provided with timing units with a wide and flexible range of features.

The common features of the different TM types are described here with more detailed information provided in the individual Compact and Periodic Type TM sections.

Introduction

The device contains four TMs having a reference name of TM0, TM1, TM2 and TM3. Each individual TM can be categorized as a certain type, namely Compact Type TM or Periodic Type TM. Although similar in nature, the different TM types vary in their feature complexity. The common features to all of the Compact and Periodic Type TMs will be described in this section and the detailed operation regarding each of the TM types will be described in separate sections. The main features and differences between the three types of TMs are summarised in the accompanying table.

TM Function	CTM	PTM
Timer/Counter	√	√
Input Capture	—	√
Compare Match Output	√	√
PWM Channels	1	1
Single Pulse Output	—	1
PWM Alignment	Edge	Edge
PWM Adjustment Period & Duty	Duty or Period	Duty or Period

TM Function Summary

This device contains a specific number of either Compact Type and Periodic Type TM units which are shown in the table together with their individual reference names, TM0~TM3.

TM0	TM1	TM2	TM3
10-bit PTM	10-bit CTM	10-bit CTM	10-bit CTM

TM Name/Type Reference

TM Operation

The different types of TM offer a diverse range of functions, from simple timing operations to PWM signal generation. The key to understanding how the TM operates is to see it in terms of a free running count-up counter whose value is then compared with the value of pre-programmed internal comparators. When the free running count-up counter has the same value as the pre-programmed comparator, known as a compare match situation, a TM interrupt signal will be generated which can clear the counter and perhaps also change the condition of the TM output pin. The internal TM counter is driven by a user selectable clock source, which can be an internal clock or an external pin.

TM Clock Source

The clock source which drives the main counter in each TM can originate from various sources. The selection of the required clock source is implemented using the TnCK2~TnCK0 bits in the TM control registers. The clock source can be a ratio of the system clock, f_{SYS} , or the internal high clock, f_H , the f_{TBC} clock source or the external TCKn pin. The TCKn pin clock source is used to allow an external signal to drive the TM as an external clock source for event counting.

TM Interrupts

The Compact Type or Periodic type TMs each has two internal interrupt, one for each of the internal comparator A or comparator P, which generate a TM interrupt when a compare match condition occurs. When a TM interrupt is generated, it can be used to clear the counter and also to change the state of the TM output pin.

TM External Pins

Each of the TMs, irrespective of what type, has one TM input pins, with the label TCKn respectively. The TM input pin is essentially a clock source for the TM and is selected using the TnCK2~TnCK0 bits in the TMnCO register. This external TM input pin allows an external clock source to drive the internal TM. This external TM input pin is shared with other functions but will be connected to the internal TM if selected using the TnCK2~TnCK0 bits. The TM input pin can be chosen to have either a rising or falling active edge.

The TMs each have one or two output pins with the label TPn. When the TM is in the Compare Match Output Mode, these pins can be controlled by the TM to switch to a high or low level or to toggle when a compare match situation occurs. The external TPn output pin is also the pin where the TM generates the PWM output waveform. As the TM output pins are pin-shared with other functions, the TM output function must first be setup using relevant register. A single bit in the register determines if its associated pin is to be used as an external TM output pin or if it is to have another function. The number of output pins for each TM type is different, the details are provided in the accompanying table. Periodic Type TM output pin names have a "_n" suffix. Pin names that include a "_0" or "_1" suffix indicate that they are from a TM with multiple output pins. This allows the TM to generate a complementary output pair, selected using the I/O register data bits.

TM0	TM1	TM2	TM3
TP0_0, TP0_1	TP1	TP2	TP3

TM Output Pins

TM Input/Output Pin Control Register

Selecting to have a TM input/output or whether to retain its other shared function is implemented using one register with a single bit in the register corresponding to a TM input/output pin. Setting the bit correctly will setup the corresponding pin as a TM input/output if reset to zero the pin will retain its original other functions.

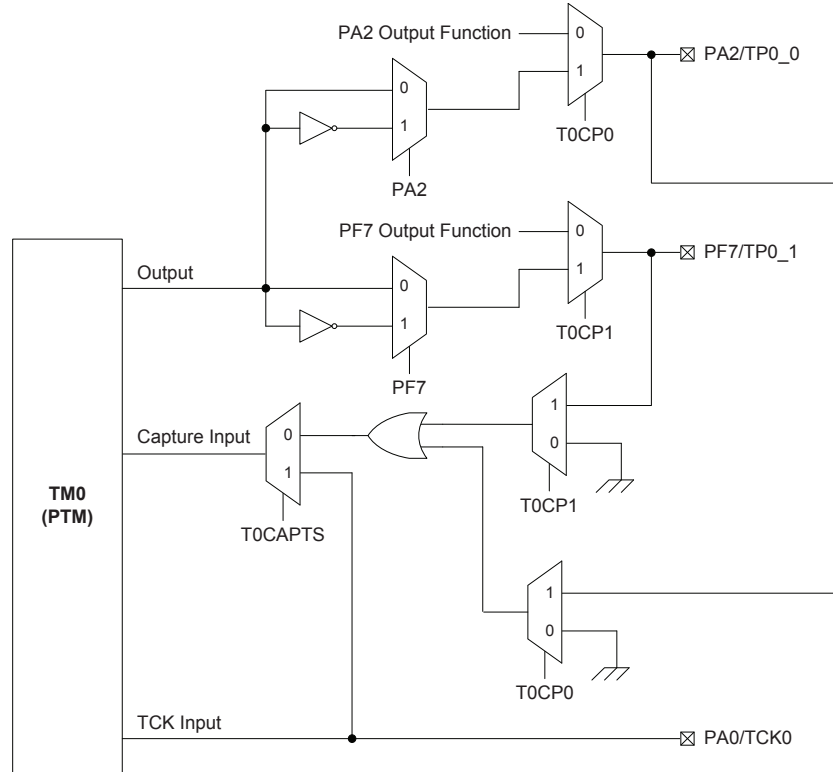

TM0 Function Pin Control Block Diagram

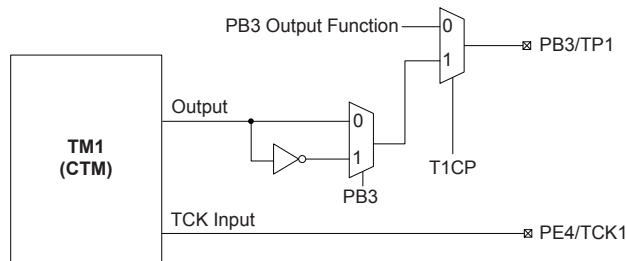

TM1 Function Pin Control Block Diagram

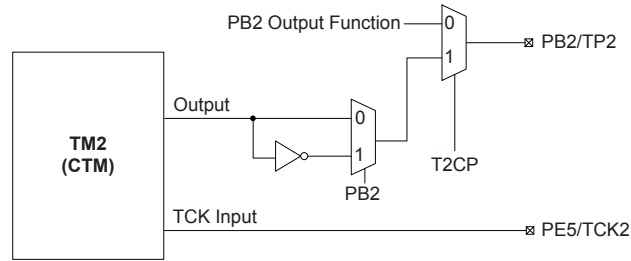

TM2 Function Pin Control Block Diagram

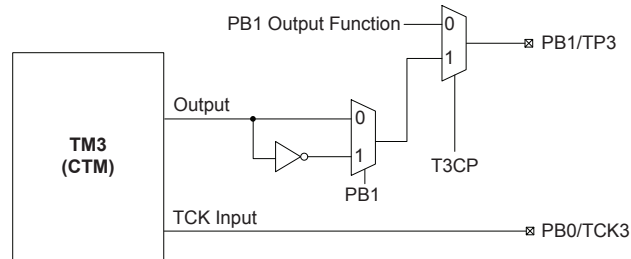

TM3 Function Pin Control Block Diagram

TMPC Register

Bit	7	6	5	4	3	2	1	0
Name	—	—	—	T3CP	T2CP	T1CP	T0CP1	T0CP0
R/W	—	—	—	R/W	R/W	R/W	R/W	R/W
POR	—	—	—	0	0	0	0	0

- Bit 7~5 Unimplemented, read as "0"
- Bit 4 **T3CP**: TP3 pin control
0: Disable
1: Enable
- Bit 3 **T2CP**: TP2 pin control
0: Disable
1: Enable
- Bit 2 **T1CP**: TP1 pin control
0: Disable
1: Enable
- Bit 1 **T0CP1**: TP0_1 pin control
0: Disable
1: Enable
- Bit 0 **T0CP0**: TP0_0 pin control
0: Disable
1: Enable

Programming Considerations

The TM Counter Registers and the Capture/Compare CCRA and CCRP registers, all have a low and high byte structure. The high bytes can be directly accessed, but as the low bytes can only be accessed via an internal 8-bit buffer, reading or writing to these register pairs must be carried out in a specific way. The important point to note is that data transfer to and from the 8-bit buffer and its related low byte only takes place when a write or read operation to its corresponding high byte is executed.

As the CCRA and CCRP registers are implemented in the way shown in the following diagram and accessing these register pairs is carried out in a specific way as described above, it is recommended to use the "MOV" instruction to access the CCRA and CCRP low byte registers, named TMnAL and TMnRPL, using the following access procedures. Accessing the CCRA or CCRP low byte registers without following these access procedures will result in unpredictable values.

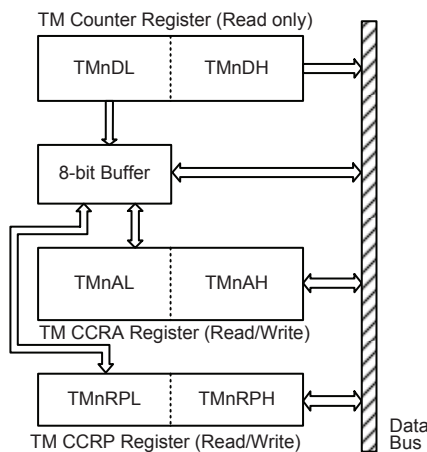

The following steps show the read and write procedures:

- Writing Data to CCRA or CCRP
 - ♦ Step 1. Write data to Low Byte TMnAL or TMnRPL
 - Note that here data is only written to the 8-bit buffer.
 - ♦ Step 2. Write data to High Byte TMnAH or TMnRPH
 - Here data is written directly to the high byte registers and simultaneously data is latched from the 8-bit buffer to the Low Byte registers.
- Reading Data from the Counter Registers and CCRA or CCRP
 - ♦ Step 1. Read data from the High Byte TMnDH, TMnAH or TMnRPH
 - Here data is read directly from the High Byte registers and simultaneously data is latched from the Low Byte register into the 8-bit buffer.
 - ♦ Step 2. Read data from the Low Byte TMnDL, TMnAL or TMnRPL
 - This step reads data from the 8-bit buffer.

Compact Type TM – CTM

The Compact Type TM contains three operating modes, which are Compare Match Output, Timer/Event Counter and PWM Output modes. The Compact Type TM can also be controlled with an external input pin and can drive one external output pin.

Name	TM No.	TM Input Pin	TM Output Pin
10-bit CTM	1, 2, 3	TCK1, TCK2, TCK3	TP1, TP2, TP3

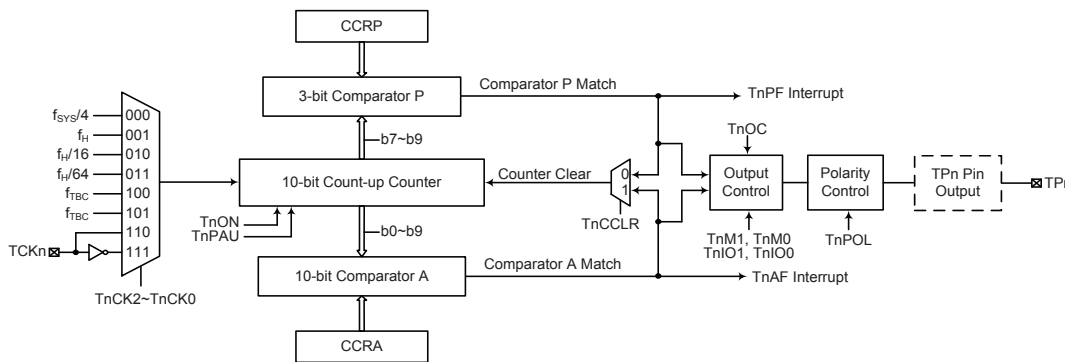

Compact Type TM Block Diagram (n=1~3)

Compact Type TM Operation

At its core is a 10-bit count-up counter which is driven by a user selectable internal clock source. There are also two internal comparators with the names, Comparator A and Comparator P. These comparators will compare the value in the counter with CCRP and CCRA registers. The CCRP is 3-bit wide whose value is compared with the highest 3 bits in the counter while the CCRA is the 10 bits and therefore compares with all counter bits.

The only way of changing the value of the 10-bit counter using the application program, is to clear the counter by changing the TnON bit from low to high. The counter will also be cleared automatically by a counter overflow or a compare match with one of its associated comparators. When these conditions occur, a TM interrupt signal will also usually be generated. The Compact Type TM can operate in a number of different operational modes, can be driven by different clock sources including an input pin and can also control an output. All operating setup conditions are selected using relevant internal registers.

Compact Type TM Register Description

Overall operation of the Compact Type TM is controlled using a series of registers. A read only register pair exists to store the internal counter 10-bit value, while a read/write register pair exists to store the internal 10-bit CCRA value. The remaining two registers are control registers which setup the different operating and control modes as well as three CCRP bits.

Register Name	Bit							
	7	6	5	4	3	2	1	0
TMnC0	TnPAU	TnCK2	TnCK1	TnCK0	TnON	TnRP2	TnRP1	TnRP0
TMnC1	TnM1	TnM0	TnIO1	TnIO0	TnOC	TnPOL	TnDPX	TnCCLR
TMnDL	D7	D6	D5	D4	D3	D2	D1	D0
TMnDH	—	—	—	—	—	—	D9	D8
TMnAL	D7	D6	D5	D4	D3	D2	D1	D0
TMnAH	—	—	—	—	—	—	D9	D8

10-bit Compact Type TM Register List (n=1~3)

TMnC0 Register

Bit	7	6	5	4	3	2	1	0
Name	TnPAU	TnCK2	TnCK1	TnCK0	TnON	TnRP2	TnRP1	TnRP0
R/W	R/W	R/W	R/W	R/W	R/W	R/W	R/W	R/W
POR	0	0	0	0	0	0	0	0

Bit 7 **TnPAU**: TMn Counter Pause Control

0: Run
1: Pause

The counter can be paused by setting this bit high. Clearing the bit to zero restores normal counter operation. When in a Pause condition the TM will remain powered up and continue to consume power. The counter will retain its residual value when this bit changes from low to high and resume counting from this value when the bit changes to a low value again.

Bit 6~4 **TnCK2~TnCK0**: Select TMn Counter Clock

000: $f_{SYS}/4$
001: f_H
010: $f_H/16$
011: $f_H/64$
100: f_{TBC}
101: f_{TBC}
110: TCKn rising edge clock
111: TCKn falling edge clock

These three bits are used to select the clock source for the TM. The external pin clock source can be chosen to be active on the rising or falling edge. The clock source f_{SYS} is the system clock, while f_H and f_{TBC} are other internal clocks, the details of which can be found in the oscillator section.

Bit 3 **TnON**: TMn Counter On/Off Control

0: Off
1: On

This bit controls the overall on/off function of the TM. Setting the bit high enables the counter to run, clearing the bit disables the TM. Clearing this bit to zero will stop the counter from counting and turn off the TM which will reduce its power consumption. When the bit changes state from low to high the internal counter value will be reset to zero, however when the bit changes from high to low, the internal counter will retain its residual value until the bit returns high again.

If the TM is in the Compare Match Output Mode or the PWM Output Mode then the TM output will be reset to its initial condition, as specified by the TnOC bit, when the TnON bit changes from low to high.

Bit 2~0 **TnRP2~TnRP0**: TMn CCRP 3-bit Register, Compared with the TMn Counter bit 9~bit 7 Comparator P Match Period

000: 1024 TMn clocks
001: 128 TMn clocks
010: 256 TMn clocks
011: 384 TMn clocks
100: 512 TMn clocks
101: 640 TMn clocks
110: 768 TMn clocks
111: 896 TMn clocks

These three bits are used to setup the value on the internal CCRP 3-bit register, which are then compared with the internal counter's highest three bits. The result of this comparison can be selected to clear the internal counter if the TnCCLR bit is set to zero. Setting the TnCCLR bit to zero ensures that a compare match with the CCRP values will reset the internal counter. As the CCRP bits are only compared with the highest three counter bits, the compare values exist in 128 clock cycle multiples. Clearing all three bits to zero is in effect allowing the counter to overflow at its maximum value.

TMnC1 Register

Bit	7	6	5	4	3	2	1	0
Name	TnM1	TnM0	TnIO1	TnIO0	TnOC	TnPOL	TnDPX	TnCCLR
R/W	R/W	R/W	R/W	R/W	R/W	R/W	R/W	R/W
POR	0	0	0	0	0	0	0	0

Bit 7~6 **TnM1~TnM0**: Select TMn Operating Mode

- 00: Compare Match Output Mode
- 01: Undefined
- 10: PWM Output Mode
- 11: Timer/Counter Mode

These bits setup the required operating mode for the TM. To ensure reliable operation the TM should be switched off before any changes are made to the TnM1 and TnM0 bits. In the Timer/Counter Mode, the TM output pin state is undefined.

Bit 5~4 **TnIO1~TnIO0**: Select TPn Output Function

Compare Match Output Mode

- 00: No change
- 01: Output low
- 10: Output high
- 11: Toggle output

PWM Output Mode

- 00: PWM output inactive state
- 01: PWM output active state
- 10: PWM output
- 11: Undefined

Timer/counter Mode

Unused

These two bits are used to determine how the TM output pin changes state when a certain condition is reached. The function that these bits select depends upon in which mode the TM is running.

In the Compare Match Output Mode, the TnIO1 and TnIO0 bits determine how the TM output pin changes state when a compare match occurs from the Comparator A. The TM output pin can be setup to switch high, switch low or to toggle its present state when a compare match occurs from the Comparator A. When the bits are both zero, then no change will take place on the output. The initial value of the TM output pin should be setup using the TnOC bit in the TMnC1 register. Note that the output level requested by the TnIO1 and TnIO0 bits must be different from the initial value setup using the TnOC bit otherwise no change will occur on the TMn output when a compare match occurs. After the TMn output pin changes state it can be reset to its initial level by changing the level of the TnON bit from low to high.

In the PWM Output Mode, the TnIO1 and TnIO0 bits determine how the TM output pin changes state when a certain compare match condition occurs. The PWM output function is modified by changing these two bits. It is necessary to only change the values of the TnIO1 and TnIO0 bits only after the TM has been switched off. Unpredictable PWM outputs will occur if the TnIO1 and TnIO0 bits are changed when the TM is running.

- Bit 3 **TnOC**: TMn Output Control Bit
 Compare Match Output Mode
 0: Initial low
 1: Initial high
 PWM Output Mode
 0: Active low
 1: Active high
- This is the output control bit for the TM output pin. Its operation depends upon whether TM is being used in the Compare Match Output Mode or in the PWM Output Mode. It has no effect if the TM is in the Timer/Counter Mode. In the Compare Match Output Mode it determines the logic level of the TM output pin before a compare match occurs. In the PWM Output Mode it determines if the PWM signal is active high or active low.
- Bit 2 **TnPOL**: TMn Output Polarity Control
 0: Non-invert
 1: Invert
- This bit controls the polarity of the TPn output pin. When the bit is set high the TM output will be inverted and not inverted when the bit is zero. It has no effect if the TM is in the Timer/Counter Mode.
- Bit 1 **TnDPX**: TMn PWM Period/Duty Control
 0: CCRP – period; CCRA – duty
 1: CCRP – duty; CCRA – period
- This bit determines which of the CCRA and CCRP registers are used for period and duty control of the PWM waveform.
- Bit 0 **TnCCLR**: Select TMn Counter Clear Condition
 0: TMn Comparatror P match
 1: TMn Comparatror A match
- This bit is used to select the method which clears the counter. Remember that the Compact type TM contains two comparators, Comparator A and Comparator P, either of which can be selected to clear the internal counter. With the TnCCLR bit set high, the counter will be cleared when a compare match occurs from the Comparator A. When the bit is low, the counter will be cleared when a compare match occurs from the Comparator P or with a counter overflow. A counter overflow clearing method can only be implemented if the CCRP bits are all cleared to zero. The TnCCLR bit is not used in the PWM Output Mode.

TMnDL Register

Bit	7	6	5	4	3	2	1	0
Name	D7	D6	D5	D4	D3	D2	D1	D0
R/W	R	R	R	R	R	R	R	R
POR	0	0	0	0	0	0	0	0

- Bit 7~0 **D7~D0**: TMn Counter Low Byte Register bit 7 ~ bit 0
 TMn 10-bit Counter bit 7 ~ bit 0

TMnDH Register

Bit	7	6	5	4	3	2	1	0
Name	—	—	—	—	—	—	D9	D8
R/W	—	—	—	—	—	—	R	R
POR	—	—	—	—	—	—	0	0

- Bit 7~2 Unimplemented, read as "0"
- Bit 1~0 **D9~D8**: TMn Counter High Byte Register bit 1 ~ bit 0
 TMn 10-bit Counter bit 9 ~ bit 8

TMnAL Register

Bit	7	6	5	4	3	2	1	0
Name	D7	D6	D5	D4	D3	D2	D1	D0
R/W	R/W	R/W	R/W	R/W	R/W	R/W	R/W	R/W
POR	0	0	0	0	0	0	0	0

Bit 7~0 **D7~D0**: TMn CCRA Low Byte Register bit 7 ~ bit 0
 TMn 10-bit CCRA bit 7 ~ bit 0

TMnAH Register

Bit	7	6	5	4	3	2	1	0
Name	—	—	—	—	—	—	D9	D8
R/W	—	—	—	—	—	—	R/W	R/W
POR	—	—	—	—	—	—	0	0

Bit 7~2 Unimplemented, read as "0"
 Bit 1~0 **D9~D8**: TMn CCRA High Byte Register bit 1 ~ bit 0
 TMn 10-bit CCRA bit 9 ~ bit 8

Compact Type TM Operating Modes

The Compact Type TM can operate in one of three operating modes, Compare Match Output Mode, PWM Output Mode or Timer/Counter Mode. The operating mode is selected using the TnM1 and TnM0 bits in the TMnC1 register.

Compare Match Output Mode

To select this mode, bits TnM1 and TnM0 in the TMnC1 register, should be set to 00 respectively. In this mode once the counter is enabled and running it can be cleared by three methods. These are a counter overflow, a compare match from Comparator A and a compare match from Comparator P. When the TnCCLR bit is low, there are two ways in which the counter can be cleared. One is when a compare match from Comparator P, the other is when the CCRP bits are all zero which allows the counter to overflow. Here both TnAF and TnPF interrupt request flags for Comparator A and Comparator P respectively, will both be generated.

If the TnCCLR bit in the TMnC1 register is high then the counter will be cleared when a compare match occurs from Comparator A. However, here only the TnAF interrupt request flag will be generated even if the value of the CCRP bits is less than that of the CCRA registers. Therefore when TnCCLR is high no TnPF interrupt request flag will be generated. If the CCRA bits are all zero, the counter will overflow when it reaches its maximum 10-bit, 3FF Hex, value, however here the TnAF interrupt request flag will not be generated.

As the name of the mode suggests, after a comparison is made, the TMn output pin will change state. The TMn output pin condition however only changes state when a TnAF interrupt request flag is generated after a compare match occurs from Comparator A. The TnPF interrupt request flag, generated from a compare match occurs from Comparator P, will have no effect on the TM output pin. The way in which the TM output pin changes state are determined by the condition of the TnIO1 and TnIO0 bits in the TMnC1 register. The TM output pin can be selected using the TnIO1 and TnIO0 bits to go high, to go low or to toggle from its present condition when a compare match occurs from Comparator A. The initial condition of the TMn output pin, which is setup after the TnON bit changes from low to high, is setup using the TnOC bit. Note that if the TnIO1 and TnIO0 bits are zero then no pin change will take place.

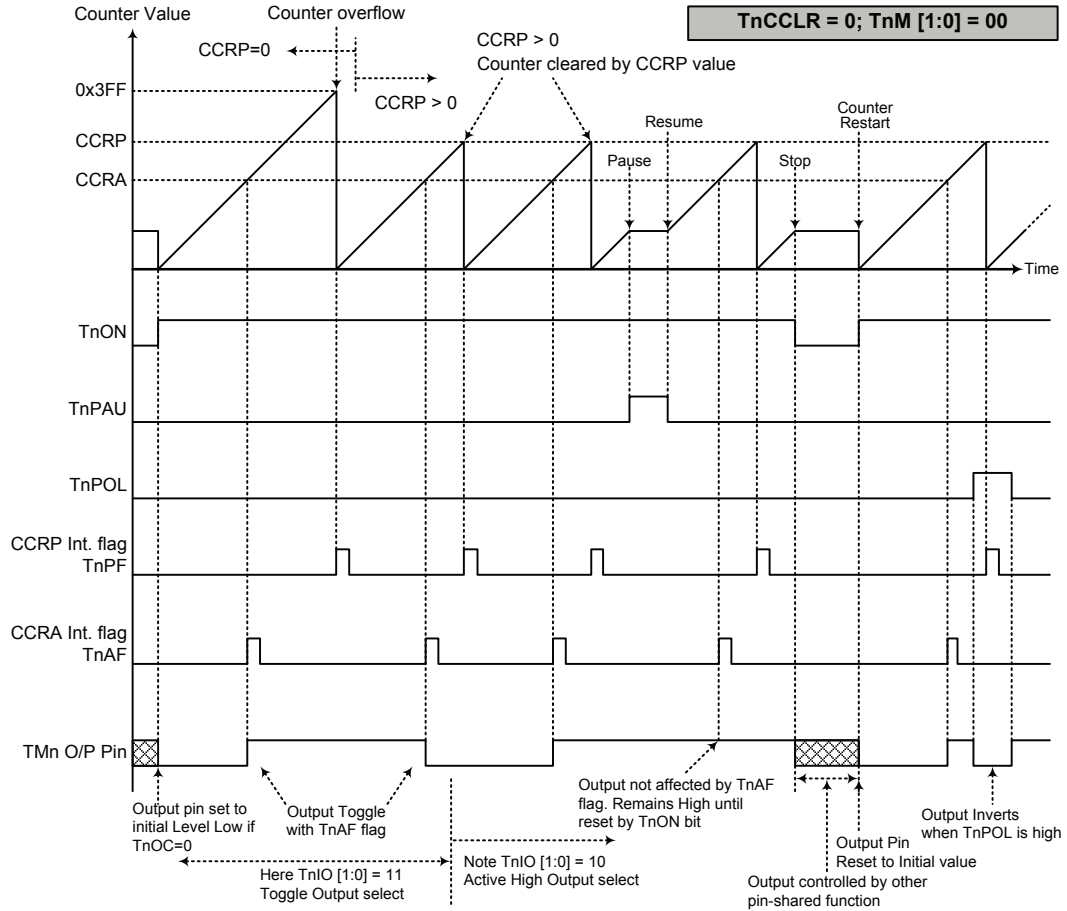

Compare Match Output Mode – TnCCLR=0 (n=1~3)

- Note: 1. With $TnCCLR=0$, a Comparator P match will clear the counter
 2. The TMn output pin controlled only by the TnAF flag
 3. The output pin reset to initial state by a TnON bit rising edge

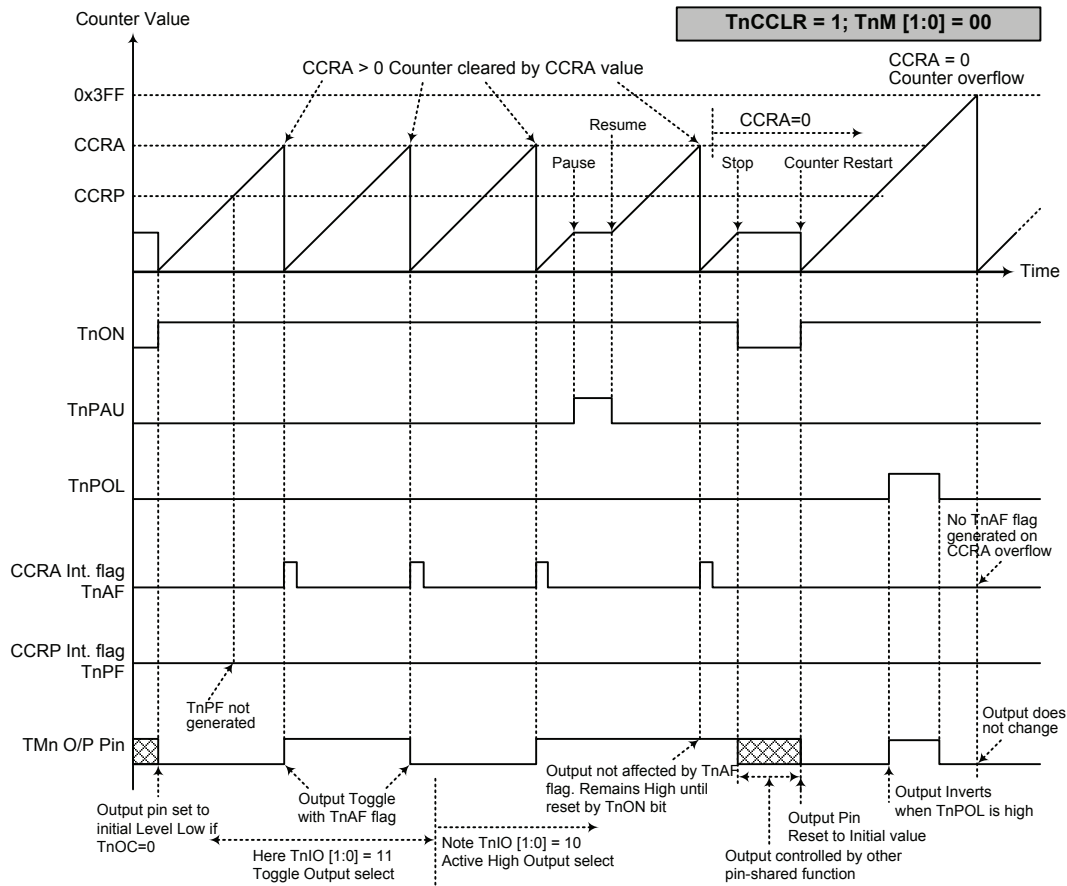

Compare Match Output Mode – TnCCLR=1 (n=1~3)

- Note: 1. With TnCCLR=1, a Comparator A match will clear the counter
 2. The TMn output pin controlled only by the TnAF flag
 3. The output pin reset to initial state by a TnON bit rising edge
 4. The TnPF flags is not generated when TnCCLR=1

Timer/Counter Mode

To select this mode, bits TnM1 and TnM0 in the TMnC1 register should be set to 11 respectively. The Timer/Counter Mode operates in an identical way to the Compare Match Output Mode generating the same interrupt flags. The exception is that in the Timer/Counter Mode the TM output is not used. Therefore the above description and Timing Diagrams for the Compare Match Output Mode can be used to understand its function.

PWM Output Mode

To select this mode, bits TnM1 and TnM0 in the TMnC1 register should be set to 10 respectively. The PWM function within the TM is useful for applications which require functions such as motor control, heating control, illumination control etc. By providing a signal of fixed frequency but of varying duty cycle on the TM output, a square wave AC waveform can be generated with varying equivalent DC RMS values.

As both the period and duty cycle of the PWM waveform can be controlled, the choice of generated waveform is extremely flexible. In the PWM Output Mode, the TnCCLR bit has no effect on the PWM operation. Both of the CCRA and CCRP registers are used to generate the PWM waveform, one register is used to clear the internal counter and thus control the PWM waveform frequency, while the other one is used to control the duty cycle. Which register is used to control either frequency or duty cycle is determined using the TnDPX bit in the TMnC1 register. The PWM waveform frequency and duty cycle can therefore be controlled by the values in the CCRA and CCRP registers.

An interrupt flag, one for each of the CCRA and CCRP, will be generated when a compare match occurs from either Comparator A or Comparator P. The TnOC bit in the TMnC1 register is used to select the required polarity of the PWM waveform while the two TnIO1 and TnIO0 bits are used to enable the PWM output or to force the TM output to a fixed high or low level. The TnPOL bit is used to reverse the polarity of the PWM output waveform.

• **10-bit CTM, PWM Output Mode, Edge-aligned Mode, TnDPX=0**

CCRP	001b	010b	011b	100b	101b	110b	111b	000b
Period	128	256	384	512	640	768	896	1024
Duty	CCRA							

If $f_{SYS}=8\text{MHz}$, TM clock source is $f_{SYS}/4$, CCRP=100b and CCRA=128,

The TM PWM output frequency= $(f_{SYS}/4) / 512=f_{SYS}/2048=3.90625\text{ kHz}$, Duty=128 / 512=25%.

If the Duty value defined by the CCRA register is equal to or greater than the Period value, then the PWM output duty is 100%.

• **10-bit CTM, PWM Output Mode, Edge-aligned Mode, TnDPX=1**

CCRP	001b	010b	011b	100b	101b	110b	111b	000b
Period	CCRA							
Duty	128	256	384	512	640	768	896	1024

The PWM output period is determined by the CCRA register value together with the TM clock while the PWM duty cycle is defined by the CCRP register value.

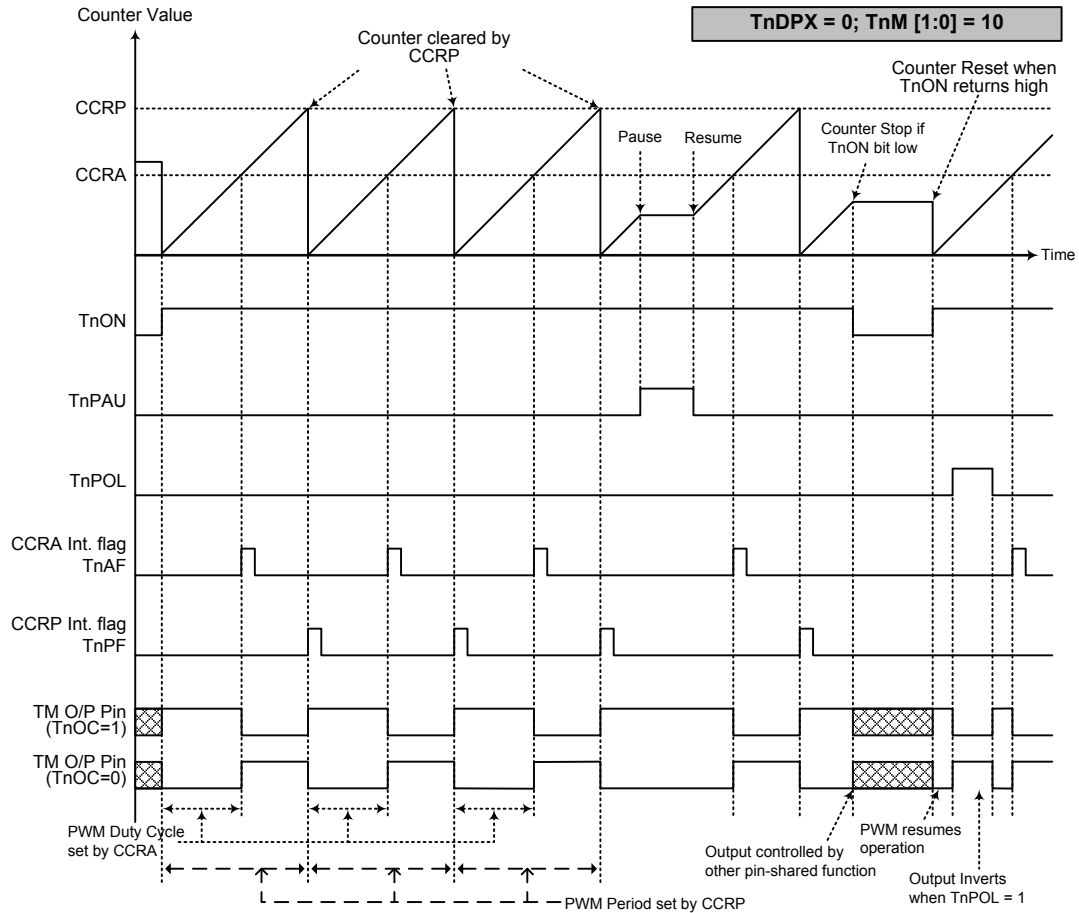

PWM Output Mode – TnDPX=0 (n=1~3)

- Note: 1. Here $TnDPX=0$ – Counter cleared by CCRP
 2. A counter clear sets PWM Period
 3. The internal PWM function continues running even when $TnIO[1:0]=00$ or 01
 4. The $TnCCLR$ bit has no influence on PWM operation.

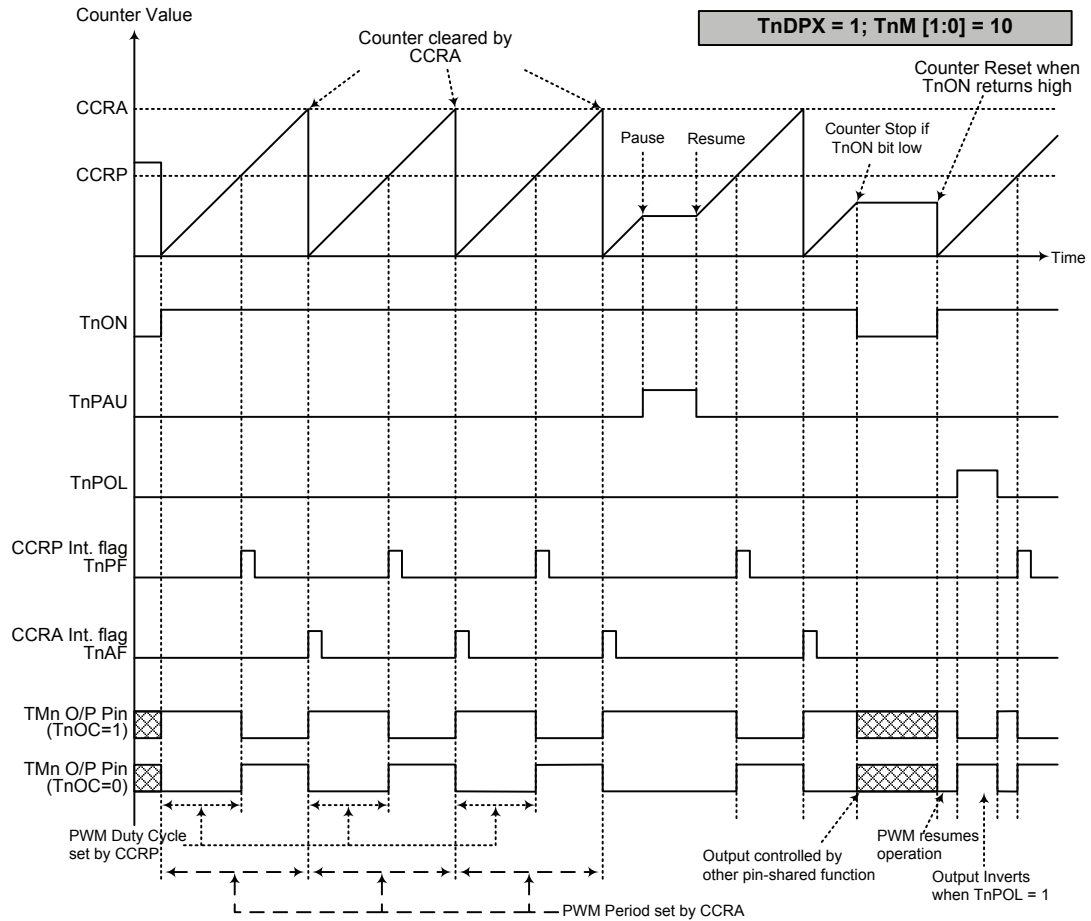

PWM Output Mode – TnDPX=1 (n=1~3)

- Note: 1. Here TnDPX=1 – Counter cleared by CCRA
 2. A counter clear sets PWM Period
 3. The internal PWM function continues even when TnIO [1:0]=00 or 01
 4. The TnCCLR bit has no influence on PWM operation.

Periodic Type TM – PTM

The Periodic Type TM contains five operating modes, which are Compare Match Output, Timer/Event Counter, Capture Input, Single Pulse Output and PWM Output modes. The Periodic TM can be controlled with external input pins and can drive external output pins.

Name	TM No.	TM Input Pin	TM Output Pin
10-bit PTM	0	TCK0, TP0_0, TP0_1	TP0_0, TP0_1

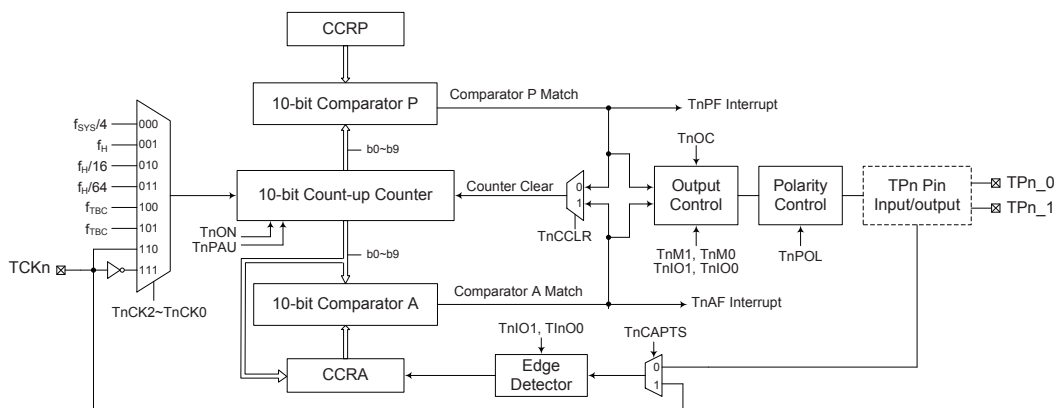

Periodic Type TM Block Diagram (n=0)

Periodic Type TM Operation

The Periodic Type TM core is a 10-bit count-up counter which is driven by a user selectable internal or external clock source. There are also two internal comparators with the names, Comparator A and Comparator P. These comparators will compare the value in the counter with CCRP and CCRA registers. The CCRP comparator is 10-bit wide.

The only way of changing the value of the 10-bit counter using the application program, is to clear the counter by changing the TnON bit from low to high. The counter will also be cleared automatically by a counter overflow or a compare match with one of its associated comparators. When these conditions occur, a TM interrupt signal will also usually be generated. The Periodic Type TM can operate in a number of different operational modes, can be driven by different clock sources including an input pin and can also control more than one output pin. All operating setup conditions are selected using relevant internal registers.

Periodic Type TM Register Description

Overall operation of the Periodic Type TM is controlled using a series of registers. A read only register pair exists to store the internal counter 10-bit value, while two read/write register pairs exist to store the internal 10-bit CCRA value and CCRP value. The remaining two registers are control registers which setup the different operating and control modes.

Register Name	Bit							
	7	6	5	4	3	2	1	0
TMnC0	TnPAU	TnCK2	TnCK1	TnCK0	TnON	—	—	—
TMnC1	TnM1	TnM0	TnIO1	TnIO0	TnOC	TnPOL	TnCAPTS	TnCCLR
TMnDL	D7	D6	D5	D4	D3	D2	D1	D0
TMnDH	—	—	—	—	—	—	D9	D8
TMnAL	D7	D6	D5	D4	D3	D2	D1	D0
TMnAH	—	—	—	—	—	—	D9	D8
TMnRPL	D7	D6	D5	D4	D3	D2	D1	D0
TMnRPH	—	—	—	—	—	—	D9	D8

10-bit Periodic TM Register List (n=0)

TMnC0 Register

Bit	7	6	5	4	3	2	1	0
Name	TnPAU	TnCK2	TnCK1	TnCK0	TnON	—	—	—
R/W	R/W	R/W	R/W	R/W	R/W	—	—	—
POR	0	0	0	0	0	—	—	—

Bit 7 **TnPAU**: TMn Counter Pause Control

0: Run
1: Pause

The counter can be paused by setting this bit high. Clearing the bit to zero restores normal counter operation. When in a Pause condition the TM will remain powered up and continue to consume power. The counter will retain its residual value when this bit changes from low to high and resume counting from this value when the bit changes to a low value again.

Bit 6~4 **TnCK2~TnCK0**: Select TMn Counter Clock

000: $f_{SYS}/4$
001: f_H
010: $f_H/16$
011: $f_H/64$
100: f_{TBC}
101: f_{TBC}
110: TCKn rising edge clock
111: TCKn falling edge clock

These three bits are used to select the clock source for the TM. The external pin clock source can be chosen to be active on the rising or falling edge. The clock source f_{SYS} is the system clock, while f_H and f_{TBC} are other internal clocks, the details of which can be found in the oscillator section.

Bit 3 **TnON**: TMn Counter On/Off Control

0: Off
1: On

This bit controls the overall on/off function of the TM. Setting the bit high enables the counter to run, clearing the bit disables the TM. Clearing this bit to zero will stop the counter from counting and turn off the TM which will reduce its power consumption. When the bit changes state from low to high the internal counter value will be reset to zero, however when the bit changes from high to low, the internal counter will retain its residual value until the bit returns high again.

If the TM is in the Compare Match Output Mode, PWM Output Mode or Single Pulse Output Mode then the TM output pin will be reset to its initial condition, as specified by the TnOC bit, when the TnON bit changes from low to high.

Bit 2~0 Unimplemented, read as "0"

TMnC1 Register

Bit	7	6	5	4	3	2	1	0
Name	TnM1	TnM0	TnIO1	TnIO0	TnOC	TnPOL	TnCAPTS	TnCCLR
R/W	R/W	R/W	R/W	R/W	R/W	R/W	R/W	R/W
POR	0	0	0	0	0	0	0	0

Bit 7~6 **TnM1~TnM0**: Select TMn Operating Mode
 00: Compare Match Output Mode
 01: Capture Input Mode
 10: PWM Output Mode or Single Pulse Output Mode
 11: Timer/Counter Mode

These bits setup the required operating mode for the TM. To ensure reliable operation the TM should be switched off before any changes are made to the TnM1 and TnM0 bits. In the Timer/Counter Mode, the TM output pin control must be disabled.

Bit 5~4 **TnIO1~TnIO0**: Select TPn_0, TPn_1 Output Function

Compare Match Output Mode
 00: No change
 01: Output low
 10: Output high
 11: Toggle output

PWM Output Mode/Single Pulse Output Mode
 00: PWM output inactive state
 01: PWM output active state
 10: PWM output
 11: Single pulse output

Capture Input Mode
 00: Input capture at rising edge of TPn_0, TPn_1 or TCKn
 01: Input capture at falling edge of TPn_0, TPn_1 or TCKn
 10: Input capture at falling/rising edge of TPn_0, TPn_1 or TCKn
 11: Input capture disabled

Timer/Counter Mode
 Unused

These two bits are used to determine how the TM output pin changes state when a certain condition is reached. The function that these bits select depends upon in which mode the TM is running.

In the Compare Match Output Mode, the TnIO1 and TnIO0 bits determine how the TM output pin changes state when a compare match occurs from the Comparator A. The TM output pin can be setup to switch high, switch low or to toggle its present state when a compare match occurs from the Comparator A. When the bits are both zero, then no change will take place on the output. The initial value of the TM output pin should be setup using the TnOC bit in the TMnC1 register. Note that the output level requested by the TnIO1 and TnIO0 bits must be different from the initial value setup using the TnOC bit otherwise no change will occur on the TM output pin when a compare match occurs. After the TM output pin changes state, it can be reset to its initial level by changing the level of the TnON bit from low to high.

In the PWM Output Mode, the TnIO1 and TnIO0 bits determine how the TM output pin changes state when a certain compare match condition occurs. The PWM output function is modified by changing these two bits. It is necessary to only change the values of the TnIO1 and TnIO0 bits only after the TM has been switched off. Unpredictable PWM outputs will occur if the TnIO1 and TnIO0 bits are changed when the TM is running.

- Bit 3 **TnOC**: TPn_0, TPn_1 Output Control bit
 Compare Match Output Mode
 0: Initial low
 1: Initial high
 PWM Output Mode/Single Pulse Output Mode
 0: Active low
 1: Active high
 This is the output control bit for the TM output pin. Its operation depends upon whether TM is being used in the Compare Match Output Mode or in the PWM Output Mode/Single Pulse Output Mode. It has no effect if the TM is in the Timer/Counter Mode. In the Compare Match Output Mode it determines the logic level of the TM output pin before a compare match occurs. In the PWM Output Mode it determines if the PWM signal is active high or active low. In the Single Pulse Output Mode it determines the logic level of the TM output pin when the TnON bit changes from low to high.
- Bit 2 **TnPOL**: TPn_0, TPn_1 Output Polarity Control
 0: Non-invert
 1: Invert
 This bit controls the polarity of the TPn_0, TPn_1 output pin. When the bit is set high the TM output pin will be inverted and not inverted when the bit is zero. It has no effect if the TM is in the Timer/Counter Mode.
- Bit 1 **TnCAPTS**: TMn Capture Trigger Source Selection
 0: From TPn_0, TPn_1 pin
 1: From TCK0 pin
- Bit 0 **TnCCLR**: Select TMn Counter Clear Condition
 0: TMn Comparator P match
 1: TMn Comparator A match
 This bit is used to select the method which clears the counter. Remember that the Periodic TM contains two comparators, Comparator A and Comparator P, either of which can be selected to clear the internal counter. With the TnCCLR bit set high, the counter will be cleared when a compare match occurs from the Comparator A. When the bit is low, the counter will be cleared when a compare match occurs from the Comparator P or with a counter overflow. A counter overflow clearing method can only be implemented if the CCRP bits are all cleared to zero. The TnCCLR bit is not used in the PWM Output Mode, Single Pulse Output or Capture Input Mode.

TMnDL Register

Bit	7	6	5	4	3	2	1	0
Name	D7	D6	D5	D4	D3	D2	D1	D0
R/W	R	R	R	R	R	R	R	R
POR	0	0	0	0	0	0	0	0

Bit 7~0 **D7~D0**: TMn Counter Low Byte Register bit 7 ~ bit 0
 TMn 10-bit Counter bit 7 ~ bit 0

TMnDH Register

Bit	7	6	5	4	3	2	1	0
Name	—	—	—	—	—	—	D9	D8
R/W	—	—	—	—	—	—	R	R
POR	—	—	—	—	—	—	0	0

Bit 7~2 Unimplemented, read as "0"
 Bit 1~0 **D9~D8**: TMn Counter High Byte Register bit 1 ~ bit 0
 TMn 10-bit Counter bit 9 ~ bit 8

TMnAL Register

Bit	7	6	5	4	3	2	1	0
Name	D7	D6	D5	D4	D3	D2	D1	D0
R/W	R/W	R/W	R/W	R/W	R/W	R/W	R/W	R/W
POR	0	0	0	0	0	0	0	0

Bit 7~0 **D7~D0**: TMn CCRA Low Byte Register bit 7 ~ bit 0
 TMn 10-bit CCRA bit 7 ~ bit 0

TMnAH Register

Bit	7	6	5	4	3	2	1	0
Name	—	—	—	—	—	—	D9	D8
R/W	—	—	—	—	—	—	R/W	R/W
POR	—	—	—	—	—	—	0	0

Bit 7~2 Unimplemented, read as "0"
 Bit 1~0 **D9~D8**: TMn CCRA High Byte Register bit 1 ~ bit 0
 TMn 10-bit CCRA bit 9 ~ bit 8

TMnRPL Register

Bit	7	6	5	4	3	2	1	0
Name	D7	D6	D5	D4	D3	D2	D1	D0
R/W	R/W	R/W	R/W	R/W	R/W	R/W	R/W	R/W
POR	0	0	0	0	0	0	0	0

Bit 7~0 **D7~D0**: TMn CCRP Low Byte Register bit 7 ~ bit 0
 TMn 10-bit CCRP bit 7 ~ bit 0

TMnRPH Register

Bit	7	6	5	4	3	2	1	0
Name	—	—	—	—	—	—	D9	D8
R/W	—	—	—	—	—	—	R/W	R/W
POR	—	—	—	—	—	—	0	0

Bit 7~2 Unimplemented, read as "0"
 Bit 1~0 **D9~D8**: TMn CCRP High Byte Register bit 1 ~ bit 0
 TMn 10-bit CCRP bit 9 ~ bit 8

Periodic Type TM Operating Modes

The Periodic Type TM can operate in one of five operating modes, Compare Match Output Mode, PWM Output Mode, Single Pulse Output Mode, Capture Input Mode or Timer/Counter Mode. The operating mode is selected using the TnM1 and TnM0 bits in the TMnC1 register.

Compare Match Output Mode

To select this mode, bits TnM1 and TnM0 in the TMnC1 register, should be set to 00 respectively. In this mode once the counter is enabled and running it can be cleared by three methods. These are a counter overflow, a compare match from Comparator A and a compare match from Comparator P. When the TnCCLR bit is low, there are two ways in which the counter can be cleared. One is when a compare match from Comparator P, the other is when the CCRP bits are all zero which allows the counter to overflow. Here both TnAF and TnPF interrupt request flags for Comparator A and Comparator P respectively, will both be generated.

If the TnCCLR bit in the TMnC1 register is high then the counter will be cleared when a compare match occurs from Comparator A. However, here only the TnAF interrupt request flag will be generated even if the value of the CCRP bits is less than that of the CCRA registers. Therefore when TnCCLR is high no TnPF interrupt request flag will be generated. In the Compare Match Output Mode, the CCRA can not be cleared to zero.

If the CCRA bits are all zero, the counter will overflow when it reaches its maximum 10-bit, 3FF Hex, value, however here the TnAF interrupt request flag will not be generated.

As the name of the mode suggests, after a comparison is made, the TM output pin, will change state. The TM output pin condition however only changes state when a TnAF interrupt request flag is generated after a compare match occurs from Comparator A. The TnPF interrupt request flag, generated from a compare match occurs from Comparator P, will have no effect on the TM output pin. The way in which the TM output pin changes state are determined by the condition of the TnIO1 and TnIO0 bits in the TMnC1 register. The TM output pin can be selected using the TnIO1 and TnIO0 bits to go high, to go low or to toggle from its present condition when a compare match occurs from Comparator A. The initial condition of the TM output pin, which is setup after the TnON bit changes from low to high, is setup using the TnOC bit. Note that if the TnIO1 and TnIO0 bits are zero then no pin change will take place.

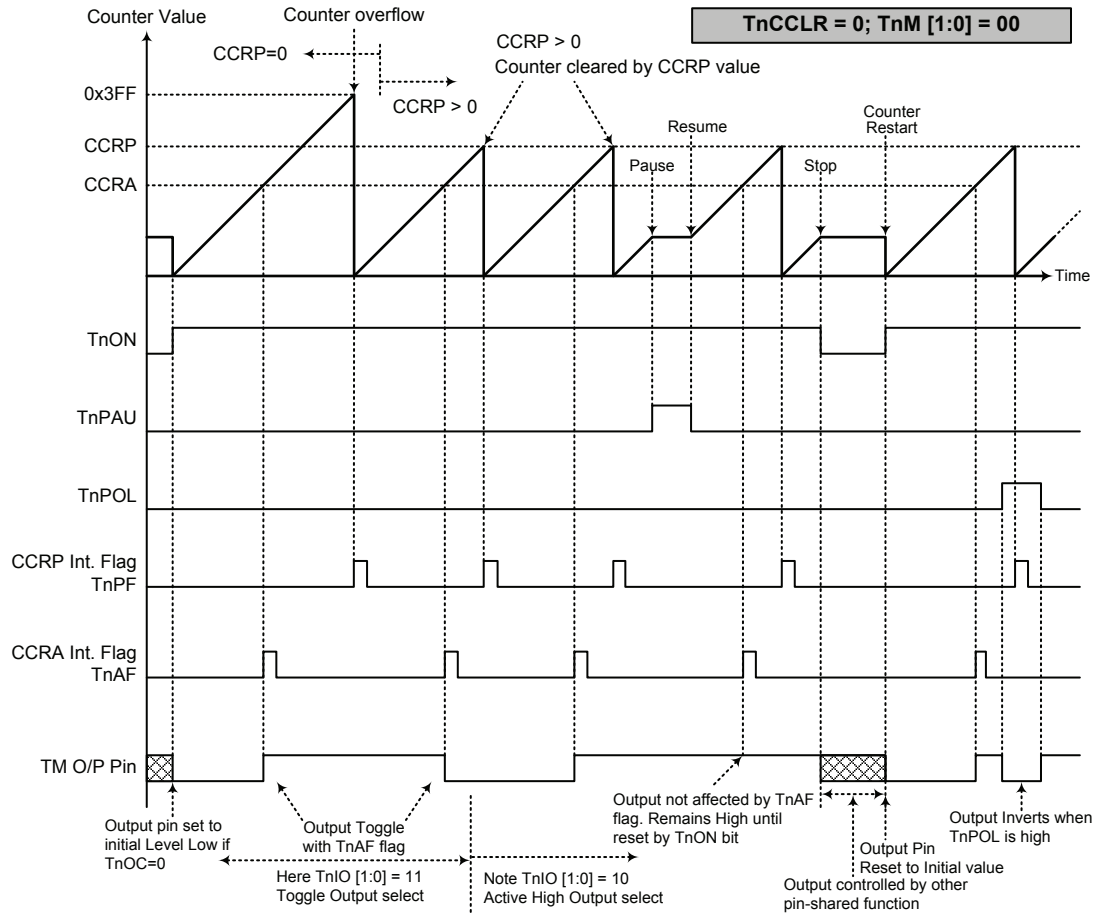

Compare Match Output Mode – TnCCLR=0 (n=0)

- Note: 1. With TnCCLR=0 a Comparator P match will clear the counter
 2. The TM output pin is controlled only by the TnAF flag
 3. The output pin is reset to its initial state by a TnON bit rising edge

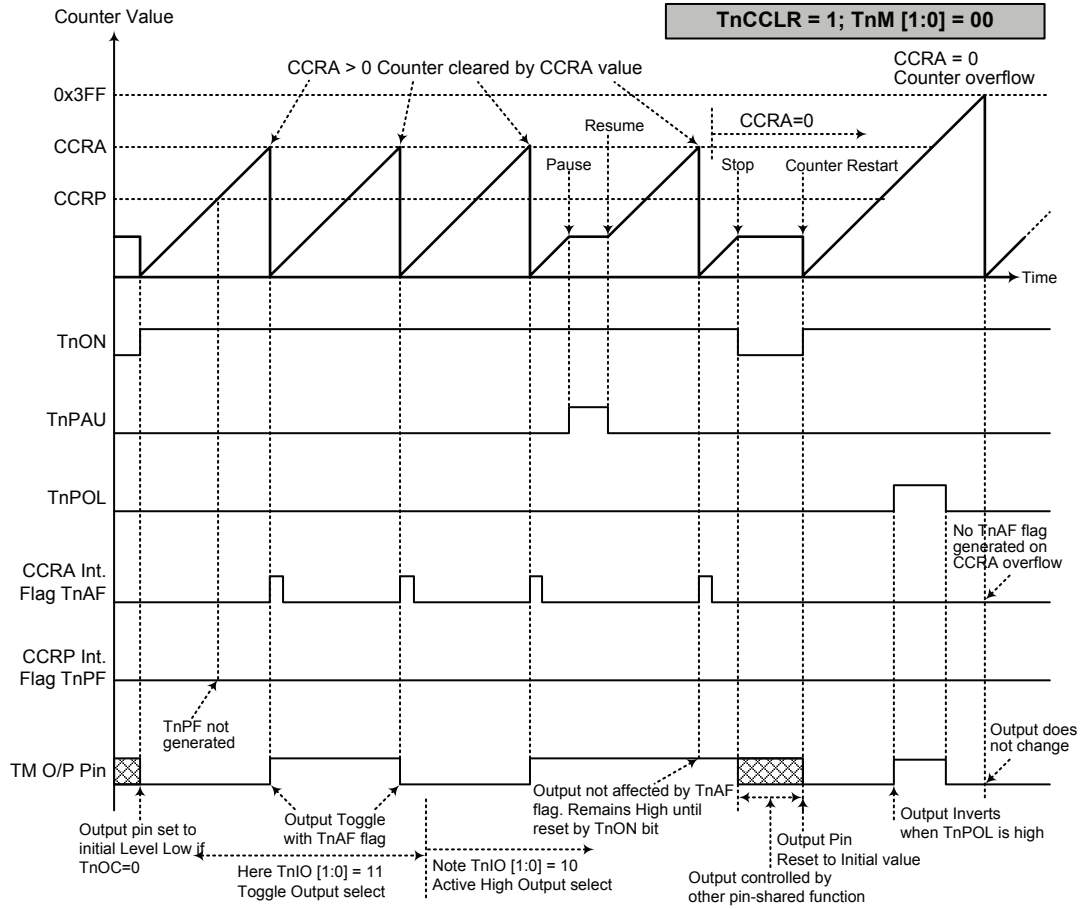

Compare Match Output Mode – TnCCLR=1 (n=0)

- Note: 1. With TnCCLR=1 a Comparator A match will clear the counter
 2. The TM output pin is controlled only by the TnAF flag
 3. The output pin is reset to its initial state by a TnON bit rising edge
 4. A TnPF flag is not generated when TnCCLR=1

Timer/Counter Mode

To select this mode, bits TnM1 and TnM0 in the TMnC1 register should be set to 11 respectively. The Timer/Counter Mode operates in an identical way to the Compare Match Output Mode generating the same interrupt flags. The exception is that in the Timer/Counter Mode the TM output pin is not used. Therefore the above description and Timing Diagrams for the Compare Match Output Mode can be used to understand its function. As the TM output pin is not used in this mode, the pin can be used as a normal I/O pin or other pin-shared function.

PWM Output Mode

To select this mode, bits TnM1 and TnM0 in the TMnC1 register should be set to 10 respectively. The PWM function within the TM is useful for applications which require functions such as motor control, heating control, illumination control etc. By providing a signal of fixed frequency but of varying duty cycle on the TM output pin, a square wave AC waveform can be generated with varying equivalent DC RMS values.

As both the period and duty cycle of the PWM waveform can be controlled, the choice of generated waveform is extremely flexible. In the PWM Output Mode, the TnCCLR bit has no effect on the PWM operation. Both of the CCRA and CCRP registers are used to generate the PWM waveform, one register is used to clear the internal counter and thus control the PWM waveform frequency, while the other one is used to control the duty cycle. The PWM waveform frequency and duty cycle can therefore be controlled by the values in the CCRA and CCRP registers.

An interrupt flag, one for each of the CCRA and CCRP, will be generated when a compare match occurs from either Comparator A or Comparator P. The TnOC bit in the TMnC1 register is used to select the required polarity of the PWM waveform while the two TnIO1 and TnIO0 bits are used to enable the PWM output or to force the TM output pin to a fixed high or low level. The TnPOL bit is used to reverse the polarity of the PWM output waveform.

- **10-bit PTM, PWM Output Mode, Edge-aligned Mode**

CCRP	1~1023	0
Period	1~1023	1024
Duty	CCRA	

If $f_{SYS}=8\text{MHz}$, TM clock source select $f_{SYS}/4$, $CCRP=512$ and $CCRA=128$,

The TM PWM output frequency= $(f_{SYS}/4)/512=f_{SYS}/2048=3.90625\text{kHz}$, duty= $128/512=25\%$.

If the Duty value defined by the CCRA register is equal to or greater than the Period value, then the PWM output duty is 100%.

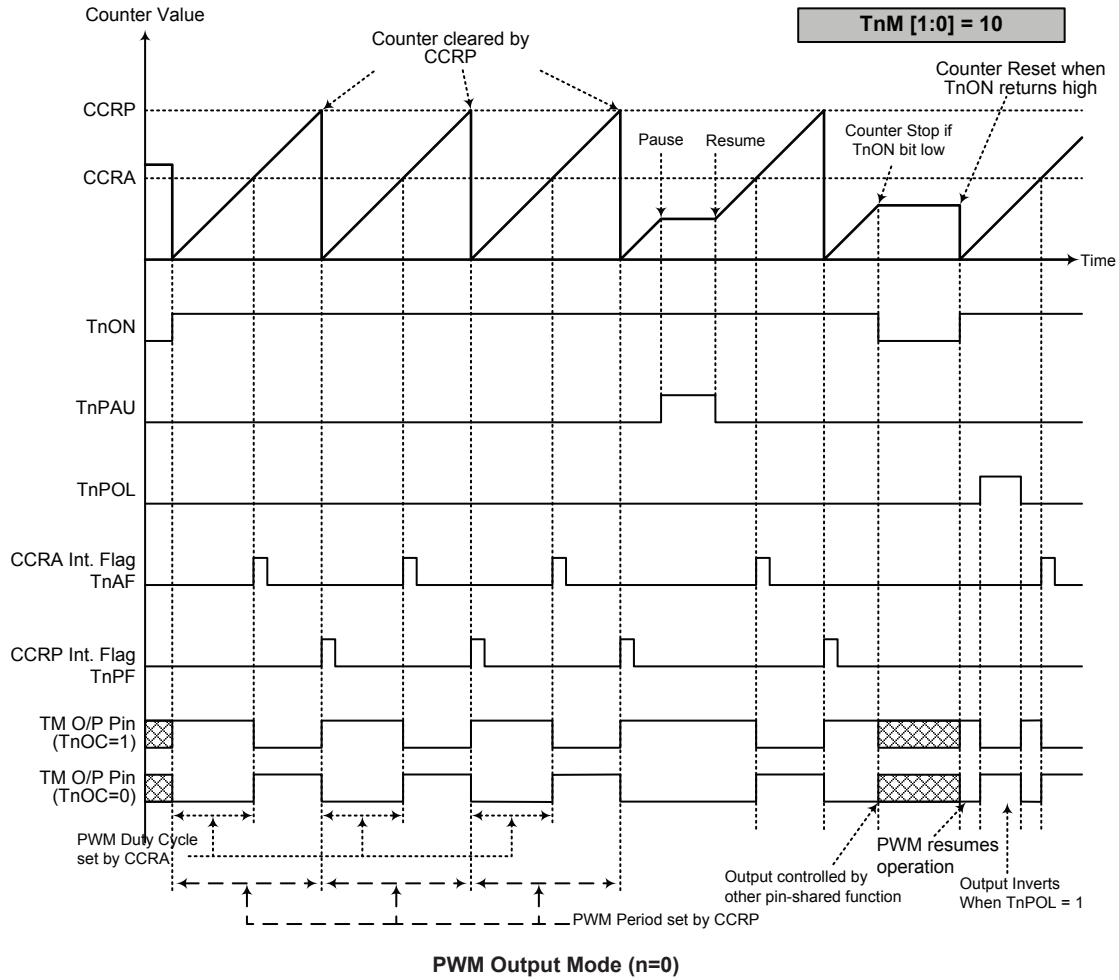

- Note:
1. Counter cleared by CCRP
 2. A counter clear sets the PWM Period
 3. The internal PWM function continues running even when TnIO[1:0]=00 or 01
 4. The TnCCLR bit has no influence on PWM operation

Single Pulse Output Mode

To select this mode, bits TnM1 and TnM0 in the TMnC1 register should be set to 10 respectively and also the TnIO1 and TnIO0 bits should be set to 11 respectively. The Single Pulse Output Mode, as the name suggests, will generate a single shot pulse on the TM output pin.

The trigger for the pulse output leading edge is a low to high transition of the TnON bit, which can be implemented using the application program. However in the Single Pulse Output Mode, the TnON bit can also be made to automatically change from low to high using the external TCKn pin, which will in turn initiate the Single Pulse output. When the TnON bit transitions to a high level, the counter will start running and the pulse leading edge will be generated. The TnON bit should remain high when the pulse is in its active state. The generated pulse trailing edge will be generated when the TnON bit is cleared to zero, which can be implemented using the application program or when a compare match occurs from Comparator A.

However a compare match from Comparator A will also automatically clear the TnON bit and thus generate the Single Pulse output trailing edge. In this way the CCRA value can be used to control the pulse width. A compare match from Comparator A will also generate a TM interrupt. The counter can only be reset back to zero when the TnON bit changes from low to high when the counter restarts. In the Single Pulse Output Mode CCRP is not used. The TnCCLR bit is not used in this Mode.

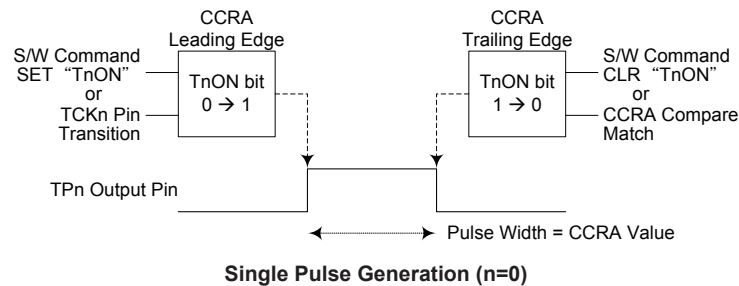

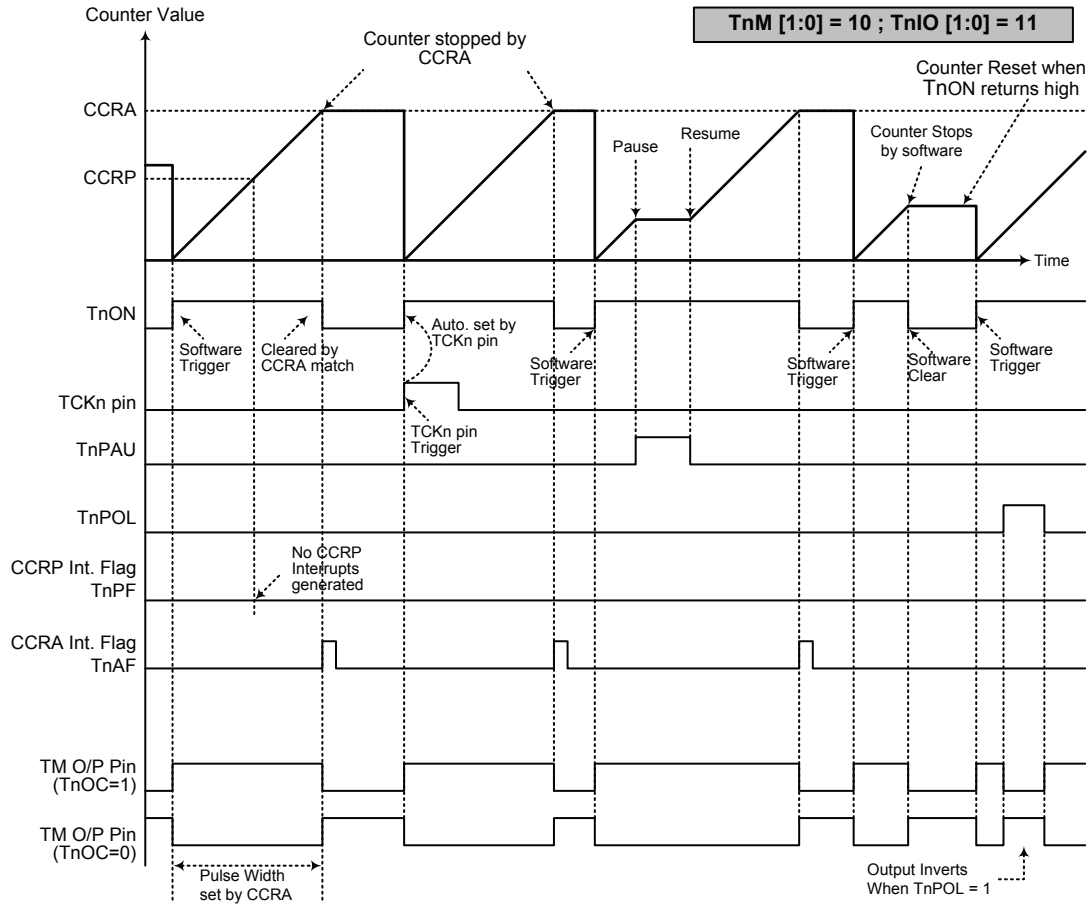

Single Pulse Output Mode (n=0)

- Note: 1. Counter stopped by CCRA
 2. CCRP is not used
 3. The pulse is triggered by the TCKn pin or by setting the TnON bit high
 4. A TCKn pin active edge will automatically set the TnON bit high
 5. In the Single Pulse Output Mode, TnIO[1:0] must be set to "11" and cannot be changed.

Capture Input Mode

To select this mode bits TnM1 and TnM0 in the TMnC1 register should be set to 01 respectively. This mode enables external signals to capture and store the present value of the internal counter and can therefore be used for applications such as pulse width measurements. The external signal is supplied on the TPn_0, TPn_1 or TCKn pin which is selected using the TnCPTS bit in the TMnC1 register. The input pin active edge can be either a rising edge, a falling edge or both rising and falling edges; the active edge transition type is selected using the TnIO1 and TnIO0 bits in the TMnC1 register. The counter is started when the TnON bit changes from low to high which is initiated using the application program.

When the required edge transition appears on the TPn_0, TPn_1 or TCKn pin the present value in the counter will be latched into the CCRA registers and a TM interrupt generated. Irrespective of what events occur on the TPn_0, TPn_1 or TCKn pin, the counter will continue to free run until the TnON bit changes from high to low. When a CCRP compare match occurs the counter will reset back to zero; in this way the CCRP value can be used to control the maximum counter value. When a CCRP compare match occurs from Comparator P, a TM interrupt will also be generated. Counting the number of overflow interrupt signals from the CCRP can be a useful method in measuring long pulse widths. The TnIO1 and TnIO0 bits can select the active trigger edge on the TPn_0, TPn_1 or TCKn pin to be a rising edge, falling edge or both edge types. If the TnIO1 and TnIO0 bits are both set high, then no capture operation will take place irrespective of what happens on the TPn_0, TPn_1 or TCKn pin, however it must be noted that the counter will continue to run.

As the TPn_0, TPn_1 or TCKn pin is pin shared with other functions, care must be taken if the TM is in the Capture Input Mode. This is because if the pin is setup as an output, then any transitions on this pin may cause an input capture operation to be executed. The TnCCLR, TnOC and TnPOL bits are not used in this Mode.

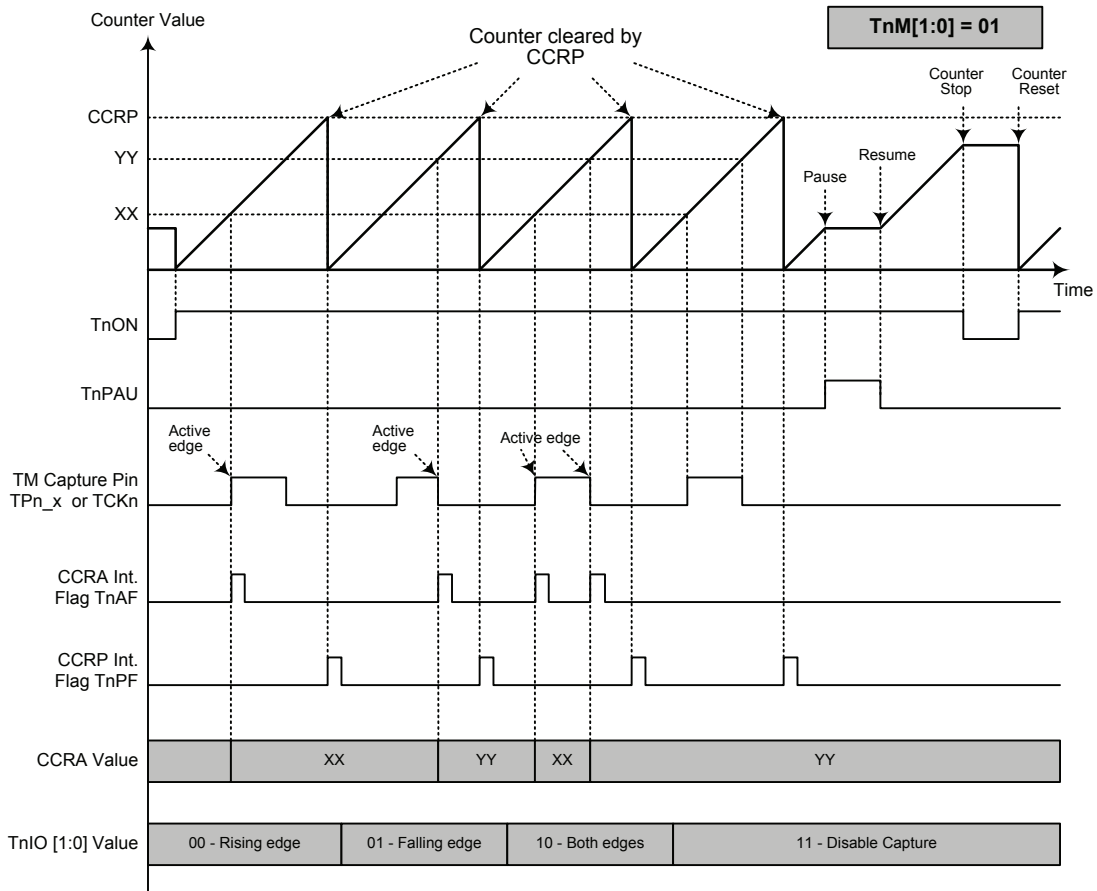

Capture Input Mode

- Note: 1. TnM[1:0]=01 and active edge set by the TnIO[1:0] bits
 2. A TM Capture input pin active edge transfers the counter value to CCRA
 3. TnCCLR bit not used
 4. No output function – TnOC and TnPOL bits are not used
 5. CCRP determines the counter value and the counter has a maximum count value when CCRP is equal to zero.

Analog to Digital Converter – ADC

The need to interface to real world analog signals is a common requirement for many electronic systems. However, to properly process these signals by a microcontroller, they must first be converted into digital signals by A/D converters. By integrating the A/D conversion electronic circuitry into the microcontroller, the need for external components is reduced significantly with the corresponding follow-on benefits of lower costs and reduced component space requirements.

A/D Converter Overview

The device contains a multi-channel analog to digital converter which can directly interface to external analog signals, such as that from sensors or other control signals and convert these signals directly into either a 12-bit digital value.

Input Channels	A/D Channel Select Bits	Input Pins
10	ACS4, ACS3~ACS0	AN0~AN9

The accompanying block diagram shows the overall internal structure of the A/D converter, together with its associated registers.

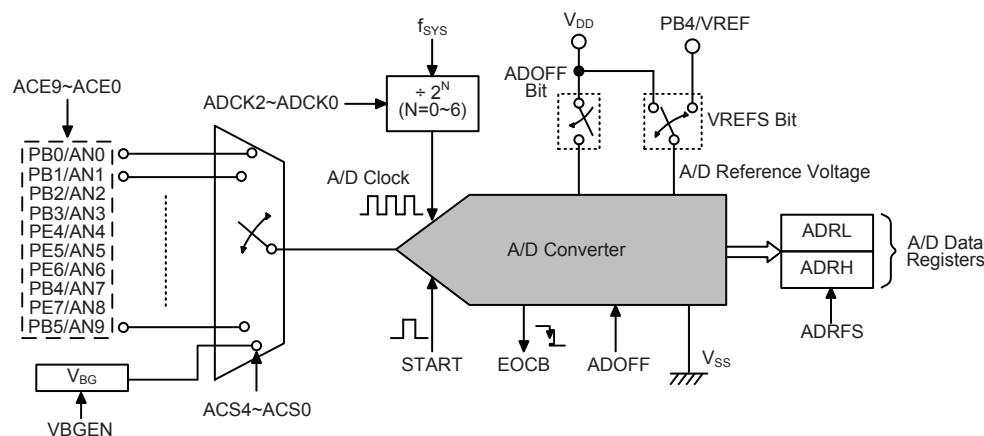

A/D Converter Structure

A/D Converter Register Description

Overall operation of the A/D converter is controlled using six registers. A read only register pair exists to store the A/D converter data 12-bit value. The remaining four registers are control registers which setup the operating and control function of the A/D converter.

Register Name	Bit							
	7	6	5	4	3	2	1	0
ADRL (ADRFS=0)	D3	D2	D1	D0	—	—	—	—
ADRL (ADRFS=1)	D7	D6	D5	D4	D3	D2	D1	D0
ADRH (ADRFS=0)	D11	D10	D9	D8	D7	D6	D5	D4
ADRH (ADRFS=1)	—	—	—	—	D11	D10	D9	D8
ADCR0	START	EOCB	ADOFF	ADRFS	ACS3	ACS2	ACS1	ACS0
ADCR1	ACS4	VBGEN	—	VREFS	—	ADCK2	ADCK1	ADCK0
ACERL	ACE7	ACE6	ACE5	ACE4	ACE3	ACE2	ACE1	ACE0
ACERH	—	—	—	—	—	—	ACE9	ACE8

A/D Converter Register List

A/D Converter Data Register – ADRL, ADRH

The device, which has an internal 12-bit A/D converter, requires two data registers, a high byte register, known as ADRH, and a low byte register, known as ADRL. After the conversion process takes place, these registers can be directly read by the microcontroller to obtain the digitised conversion value. As only 12 bits of the 16-bit register space is utilised, the format in which the data is stored is controlled by the ADRFS bit in the ADCR0 register as shown in the accompanying table.

D0~D11 are the A/D conversion result data bits. Any unused bits will be read as zero.

ADRFS	ADRH								ADRL							
	7	6	5	4	3	2	1	0	7	6	5	4	3	2	1	0
0	D11	D10	D9	D8	D7	D6	D5	D4	D3	D2	D1	D0	—	—	—	—
1	—	—	—	—	D11	D10	D9	D8	D7	D6	D5	D4	D3	D2	D1	D0

A/D converter Data Registers

A/D Converter Control Registers – ADCR0, ADCR1, ACERL, ACERH

To control the function and operation of the A/D converter, four control registers known as ADCR0, ADCR1, ACERL and ACERH are provided. These 8-bit registers define functions such as the selection of which analog channel is connected to the internal A/D converter, the digitised data format, the A/D converter clock source as well as controlling the start function and monitoring the end of A/D conversion status. The ACS3~ACS0 bits in the ADCR0 register and the ACS4 bit in the ADCR1 register define the A/D converter input channel number. As the device contains only one actual analog to digital converter hardware circuit, each of the individual analog inputs must be routed to the converter. It is the function of the ACS4~ACS0 bits to determine which analog channel input pin or internal V_{BG} is actually connected to the internal A/D converter.

The ACERH and ACERL control registers contain the ACE9~ACE0 bits which determine which pins on I/O ports are used as analog inputs for the A/D converter input and which pins are not to be used as the A/D converter input. Setting the corresponding bit high will select the A/D converter input function, clearing the bit to zero will select either the I/O or other pin-shared function. When the pin is selected to be an A/D input, its original function whether it is an I/O or other pin-shared function will be removed. In addition, any internal pull-high resistors connected to these pins will be automatically removed if the pin is selected to be an A/D input.

• ADCR0 Register

Bit	7	6	5	4	3	2	1	0
Name	START	EOCB	ADOFF	ADRFS	ACS3	ACS2	ACS1	ACS0
R/W	R/W	R	R/W	R/W	R/W	R/W	R/W	R/W
POR	0	1	1	0	0	0	0	0

Bit 7 **START**: Start the A/D conversion

0→1→0: Start

0→1: Reset the A/D converter and set EOCB to "1"

This bit is used to initiate an A/D conversion process. The bit is normally low but if set high and then cleared low again, the A/D converter will initiate a conversion process. When the bit is set high the A/D converter will be reset.

Bit 6 **EOCB**: End of A/D conversion flag

0: A/D conversion ended

1: A/D conversion in progress

This read only flag is used to indicate when an A/D conversion process has completed. When the conversion process is running, the bit will be high.

- Bit 5 **ADOFF**: A/D converter module power on/off control bit
 0: A/D converter module power on
 1: A/D converter module power off
 This bit controls the power to the A/D internal function. This bit should be cleared to zero to enable the A/D converter. If the bit is set high then the A/D converter will be switched off reducing the device power consumption. As the A/D converter will consume a limited amount of power, even when not executing a conversion, this may be an important consideration in power sensitive battery powered applications.
 Note: 1. It is recommended to set ADOFF=1 before entering IDLE/SLEEP Mode for saving power.
 2. ADOFF=1 will power down the A/D converter module.
- Bit 4 **ADRF5**: A/D data format control bit
 0: A/D converter Data MSB is ADRH bit 7, LSB is ADRL bit 4
 1: A/D converter Data MSB is ADRH bit 3, LSB is ADRL bit 0
 This bit controls the format of the 12-bit converted A/D value in the two A/D data registers. Details are provided in the A/D data register section.
- Bit 3~0 **ACS3~ACS0**: Select A/D channel (when ACS4 is "0")
 0000: AN0
 0001: AN1
 0010: AN2
 0011: AN3
 0100: AN4
 0101: AN5
 0110: AN6
 0111: AN7
 1000: AN8
 1001~1111: AN9
 These are the A/D channel select control bits. As there is only one internal hardware A/D converter each of the ten A/D inputs must be routed to the internal converter using these bits. If the ACS4 bit is set high, then the internal Bandgap V_{BG} will be routed to the A/D converter.

• **ADCR1 Register**

Bit	7	6	5	4	3	2	1	0
Name	ACS4	VBGEN	—	VREFS	—	ADCK2	ADCK1	ADCK0
R/W	R/W	R/W	—	R/W	—	R/W	R/W	R/W
POR	0	0	—	0	—	0	0	0

- Bit 7 **ACS4**: Select internal V_{BG} as A/D converter input control
 0: Disable
 1: Enable
 This bit enables V_{BG} to be connected to the A/D converter. The VBGEN bit must first have been set to enable the bandgap circuit V_{BG} voltage to be used by the A/D converter. When the ACS4 bit is set high, the bandgap V_{BG} voltage will be routed to the A/D converter and the other A/D input channels disconnected.
- Bit 6 **VBGEN**: internal V_{BG} control
 0: Disable
 1: Enable
 This bit controls the internal Bandgap circuit on/off function to the A/D converter. When the bit is set high the bandgap voltage V_{BG} can be used by the A/D converter. If V_{BG} is not used by the A/D converter and the LVR/LVD function is disabled then the bandgap reference circuit will be automatically switched off to conserve power. When V_{BG} is switched on for use by the A/D converter, a time t_{BGS} should be allowed for the bandgap circuit to stabilise before implementing an A/D conversion.
- Bit 5 Unimplemented, read as "0"

Bit 4 **VREFS**: Select A/D converter reference voltage
 0: Internal A/D converter power
 1: VREF pin

This bit is used to select the reference voltage for the A/D converter. If the bit is high, then the A/D converter reference voltage is supplied on the external VREF pin. If the pin is low, then the internal reference is used which is taken from the power supply pin VDD. When the A/D converter reference voltage is supplied on the external VREF pin which is pin-shared with other functions, all of the pin-shared functions except VREF on this pin are disabled.

Bit 3 Unimplemented, read as "0"

Bit 2~0 **ADCK2~ADCK0**: Select A/D converter clock source
 000: f_{SYS}
 001: $f_{SYS}/2$
 010: $f_{SYS}/4$
 011: $f_{SYS}/8$
 100: $f_{SYS}/16$
 101: $f_{SYS}/32$
 110: $f_{SYS}/64$
 111: Undefined

These three bits are used to select the clock source for the A/D converter.

• **Bandgap reference voltage on/off true table:**

ACS4	VBGEN	LVR/LVD	V _{BG}	Bandgap Reference Voltage
x	0	Enable	Off to GND	On
x	0	Disable	Off to GND	Off
x	1	x	On	On

x: Don't care

• **ACERL Register**

Bit	7	6	5	4	3	2	1	0
Name	ACE7	ACE6	ACE5	ACE4	ACE3	ACE2	ACE1	ACE0
R/W	R/W	R/W	R/W	R/W	R/W	R/W	R/W	R/W
POR	0	0	0	0	0	0	0	0

Bit 7 **ACE7**: Define PB4 is A/D input or not
 0: Not A/D input
 1: A/D input, AN7

Bit 6 **ACE6**: Define PE6 is A/D input or not
 0: Not A/D input
 1: A/D input, AN6

Bit 5 **ACE5**: Define PE5 is A/D input or not
 0: Not A/D input
 1: A/D input, AN5

Bit 4 **ACE4**: Define PE4 is A/D input or not
 0: Not A/D input
 1: A/D input, AN4

Bit 3 **ACE3**: Define PB3 is A/D input or not
 0: Not A/D input
 1: A/D input, AN3

Bit 2 **ACE2**: Define PB2 is A/D input or not
 0: Not A/D input
 1: A/D input, AN2

Bit 1 **ACE1**: Define PB1 is A/D input or not
 0: Not A/D input
 1: A/D input, AN1

Bit 0 **ACE0**: Define PB0 is A/D input or not
 0: Not A/D input
 1: A/D input, AN0

• **ACERL Register**

Bit	7	6	5	4	3	2	1	0
Name	—	—	—	—	—	—	ACE9	ACE8
R/W	—	—	—	—	—	—	R/W	R/W
POR	—	—	—	—	—	—	0	0

- Bit 7~2 Unimplemented, read as "0"
- Bit 1 **ACE9**: Define PB5 is A/D input or not
 0: Not A/D input
 1: A/D input, AN9
- Bit 0 **ACE8**: Define PE7 is A/D input or not
 0: Not A/D input
 1: A/D input, AN8

A/D Converter Operation

The START bit in the ADCR0 register is used to start and reset the A/D converter. When the microcontroller sets this bit from low to high and then low again, an analog to digital conversion cycle will be initiated. When the START bit is brought from low to high but not low again, the EOCB bit in the ADCR0 register will be set high and the analog to digital converter will be reset. It is the START bit that is used to control the overall start operation of the internal analog to digital converter.

The EOCB bit in the ADCR0 register is used to indicate when the analog to digital conversion process is complete. This bit will be automatically set to "0" by the microcontroller after a conversion cycle has ended. In addition, the corresponding A/D interrupt request flag will be set in the interrupt control register, and if the interrupts are enabled, an appropriate internal interrupt signal will be generated. This A/D internal interrupt signal will direct the program flow to the associated A/D internal interrupt address for processing. If the A/D internal interrupt is disabled, the microcontroller can be used to poll the EOCB bit in the ADCR0 register to check whether it has been cleared as an alternative method of detecting the end of an A/D conversion cycle.

The clock source for the A/D converter, which originates from the system clock f_{SYS} , can be chosen to be either f_{SYS} or a subdivided version of f_{SYS} . The division ratio value is determined by the ADCK2~ADCK0 bits in the ADCR1 register.

Although the A/D clock source is determined by the system clock f_{SYS} , and by bits ADCK2~ADCK0, there are some limitations on the A/D clock source speed range that can be selected. As the recommended range of permissible A/D clock period, t_{ADCK} , is from 0.5 μ s to 10 μ s, care must be taken for selected system clock frequencies. For example, if the system clock operates at a frequency of 4MHz, the ADCK2~ADCK0 bits should not be set to 000B or 110B. Doing so will give A/D clock periods that are less than the minimum A/D clock period or greater than the maximum A/D clock period which may result in inaccurate A/D conversion values.

Refer to the following table for examples, where values marked with an asterisk * show where, depending upon the device, special care must be taken, as the values may be beyond the specified A/D clock period range.

f _{sys}	A/D Clock Period (t _{ADCK})							
	ADCK [2:0]=000 (f _{sys})	ADCK [2:0]=001 (f _{sys} /2)	ADCK [2:0]=010 (f _{sys} /4)	ADCK [2:0]=011 (f _{sys} /8)	ADCK [2:0]=100 (f _{sys} /16)	ADCK [2:0]=101 (f _{sys} /32)	ADCK [2:0]=110 (f _{sys} /64)	ADCK [2:0]=111
1MHz	1μs	2μs	4μs	8μs	16μs*	32μs*	64μs*	Undefined
2MHz	500ns	1μs	2μs	4μs	8μs	16μs*	32μs*	Undefined
4MHz	250ns*	500ns	1μs	2μs	4μs	8μs	16μs*	Undefined
8MHz	125ns*	250ns*	500ns	1μs	2μs	4μs	8μs	Undefined

A/D Clock Period Examples

Controlling the power on/off function of the A/D converter circuitry is implemented using the ADOFF bit in the ADCR0 register. This bit must be zero to power on the A/D converter. When the ADOFF bit is cleared to zero to power on the A/D converter internal circuitry a certain delay, as indicated in the timing diagram, must be allowed before an A/D conversion is initiated. Even if no pins are selected for use as A/D inputs by clearing the ACE9~ACE0 bits in the ACERL registers, if the ADOFF bit is zero then some power will still be consumed. In power conscious applications it is therefore recommended that the ADOFF is set high to reduce power consumption when the A/D converter function is not being used.

A/D Converter Reference Voltage

The reference voltage supply to the A/D Converter can be supplied from either the positive power supply pin, VDD, or from an external reference sources supplied on pin VREF. The desired selection is made using the VREFS bit. As the VREF pin is pin-shared with other functions, when the VREFS bit is set high, the VREF pin function will be selected and the other pin functions will be disabled automatically.

A/D Converter Input Signals

All of the A/D analog input pins are pin-shared with the I/O pins as well as other functions. The ACE9~ACE0 bits in the ACERH and ACERL registers, determine whether the input pins are setup as A/D converter analog inputs or whether they have other functions. If the ACE9~ACE0 bits for its corresponding pin is set high then the pins will be setup to be an A/D converter input and the original pin functions disabled. In this way, pins can be changed under program control to change their function between A/D inputs and other functions. All pull-high resistors, which are setup through register programming, will be automatically disconnected if the pins are setup as A/D inputs. Note that it is not necessary to first setup the A/D pin as an input in the port control register to enable the A/D input as when the ACE9~ACE0 bits enable an A/D input, the status of the port control register will be overridden.

The A/D converter has its own reference voltage pin, VREF. However the reference voltage can also be supplied from the power supply pin, a choice which is made through the VREFS bit in the ADCR1 register. The analog input values must not be allowed to exceed the value of V_{REF}.

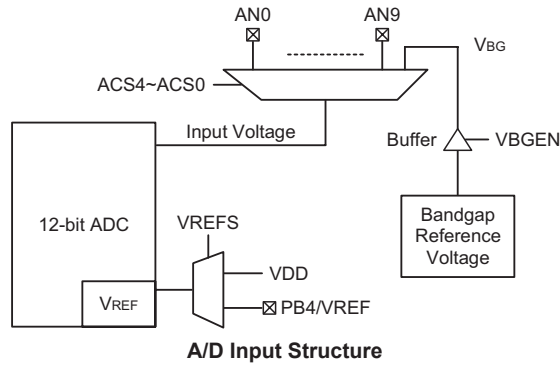

Conversion Rate and Timing Diagram

A complete A/D conversion contains two parts, data sampling and data conversion. The data sampling which is defined as t_{ADS} takes 4 A/D clock cycles and the data conversion takes 12 A/D clock cycles. Therefore a total of 16 A/D clock cycles for an external input A/D conversion which is defined as t_{ADC} are necessary.

$$\text{Maximum single A/D conversion rate} = \text{A/D clock period} / 16$$

The accompanying diagram shows graphically the various stages involved in an analog to digital conversion process and its associated timing. After an A/D conversion process has been initiated by the application program, the microcontroller internal hardware will begin to carry out the conversion, during which time the program can continue with other functions. The time taken for the A/D conversion is $16 t_{ADCK}$ clock cycles where t_{ADCK} is equal to the A/D clock period.

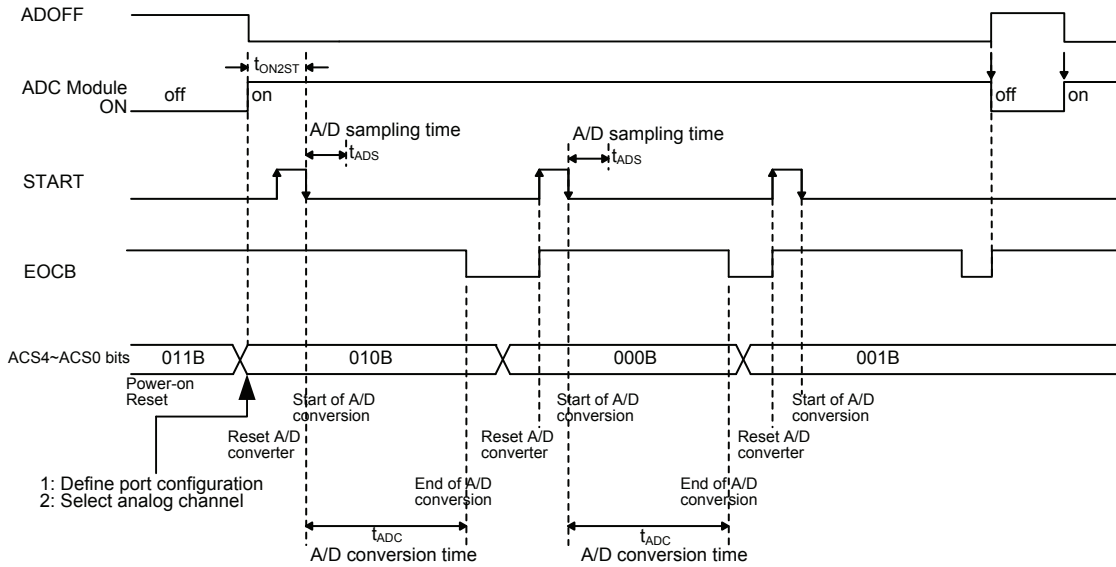

A/D Conversion Timing

Summary of A/D Conversion Steps

The following summarises the individual steps that should be executed in order to implement an A/D conversion process.

- Step 1
Select the required A/D conversion clock by correctly programming bits ADCK2~ADCK0 in the ADCR1 register.
- Step 2
Enable the A/D by clearing the ADOFF bit in the ADCR0 register to zero.
- Step 3
Select which channel is to be connected to the internal A/D converter by correctly programming the ACS4~ACS0 bits which are also contained in the ADCR1 and ADCR0 register.
- Step 4
Select which pins are to be used as A/D inputs and configure them by correctly programming the ACE9~ACE0 bits in the ACERH and ACERL register.
- Step 5
If the interrupts are to be used, the interrupt control registers must be correctly configured to ensure the A/D converter interrupt function is active. The master interrupt control bit, EMI, and the A/D converter interrupt bit, ADE, must both be set high to do this.
- Step 6
The analog to digital conversion process can now be initialised by setting the START bit in the ADCR0 register from low to high and then low again. Note that this bit should have been originally cleared to zero.
- Step 7
To check when the analog to digital conversion process is complete, the EOCB bit in the ADCR0 register can be polled. The conversion process is complete when this bit goes low. When this occurs the A/D data registers ADRL and ADRH can be read to obtain the conversion value. As an alternative method, if the interrupts are enabled and the stack is not full, the program can wait for an A/D interrupt to occur.

Note: When checking for the end of the conversion process, if the method of polling the EOCB bit in the ADCR0 register is used, the interrupt enable step above can be omitted.

Programming Considerations

During microcontroller operations where the A/D converter is not being used, the A/D internal circuitry can be switched off to reduce power consumption, by setting bit ADOFF high in the ADCR0 register. When this happens, the internal A/D converter circuits will not consume power irrespective of what analog voltage is applied to their input lines. If the A/D converter input lines are used as normal I/Os, then care must be taken as if the input voltage is not at a valid logic level, then this may lead to some increase in power consumption.

A/D Conversion Function

As the device contains a 12-bit A/D converter, its full-scale converted digitised value is equal to FFFH. Since the full-scale analog input value is equal to the actual A/D converter reference voltage, V_{REF} voltage, this gives a single bit analog input value of V_{REF} divided by 4096.

$$1 \text{ LSB} = V_{REF}/4096$$

The A/D Converter input voltage value can be calculated using the following equation:

$$\text{A/D input voltage} = \text{A/D output digital value} \times V_{REF}/4096$$

The diagram shows the ideal transfer function between the analog input value and the digitised output value for the A/D converter. Except for the digitised zero value, the subsequent digitised values will change at a point 0.5 LSB below where they would change without the offset, and the last full scale digitised value will change at a point 1.5 LSB below the V_{REF} level. Note that here the V_{REF} voltage is the actual A/D converter reference voltage determined by the VREFS bit.

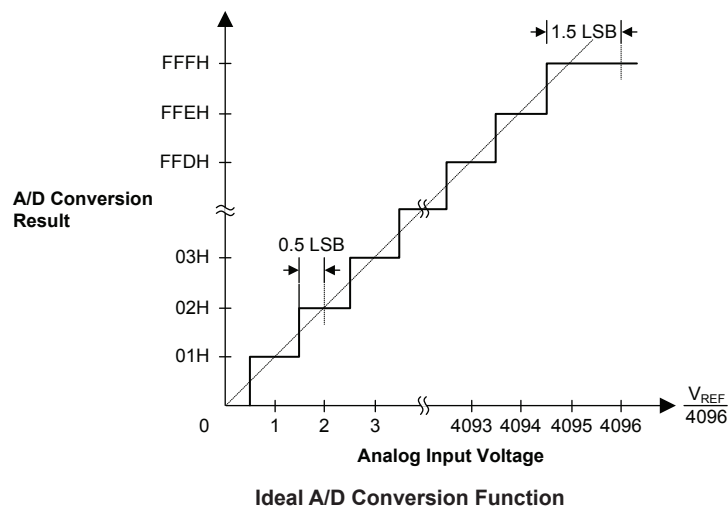

A/D Conversion Programming Examples

The following two programming examples illustrate how to setup and implement an A/D conversion. In the first example, the method of polling the EOCB bit in the ADCR0 register is used to detect when the conversion cycle is complete, whereas in the second example, the A/D interrupt is used to determine when the conversion is complete.

Example: using an EOCB polling method to detect the end of conversion

```
clr ADE          ; disable A/D converter interrupt
mov a, 03H
mov ADCR1, a     ; select fsys/8 as A/D clock and switch off VBG
clr ADOFF
mov a, 0Fh      ; setup ACERL to configure pins AN0~AN3
mov ACERL, a
mov a, 00h
mov ACERH, a
mov a, 00h
mov ADCR0, a    ; enable and connect AN0 channel to A/D converter
:
:
Start_conversion:
clr START
set START       ; reset A/D
clr START       ; start A/D
Polling_EOC:
sz EOCB        ; poll the ADCR0 register EOCB bit to detect end of A/D conversion
jmp polling_EOC ; continue polling
mov a, ADRL    ; read low byte conversion result value
mov adrl_buffer, a ; save result to user defined register
mov a, ADRH    ; read high byte conversion result value
mov adrh_buffer, a ; save result to user defined register
:
jmp start_conversion ; start next A/D conversion
```

Note: To power off the A/D converter, it is necessary to set ADOFF as "1".

Example: using the interrupt method to detect the end of conversion

```
clr ADE          ; disable A/D converter interrupt
mov a, 03H
mov ADCR1, a     ; select fsys/8 as A/D clock and switch off VBG
clr ADOFF
mov a, 0Fh      ; setup ACERL to configure pins AN0~AN3
mov ACERL, a
mov a, 00h
mov ACERH, a
mov a, 00h
mov ADCR0, a    ; enable and connect AN0 channel to A/D converter
:
:
Start_conversion:
clr START
set  START      ; reset A/D
clr START      ; start A/D
clr ADF         ; clear A/D converter interrupt request flag
set  ADE        ; enable A/D converter interrupt
set  EMI        ; enable global interrupt
:
:
; A/D converter interrupt service routine
ADC_ISR:
mov  acc_stack, a ; save ACC to user defined memory
mov  a, STATUS
mov  status_stack, a ; save STATUS to user defined memory
:
:
mov  a, ADRL     ; read low byte conversion result value
mov  adr1_buffer, a ; save result to user defined register
mov  a, ADRH     ; read high byte conversion result value
mov  adrh_buffer, a ; save result to user defined register
:
:
EXIT_ISR:
mov  a, status_stack
mov  STATUS, a ; restore STATUS from user defined memory
mov  a, acc_stack ; restore ACC from user defined memory
clr  ADF         ; clear A/D converter interrupt flag
reti
```

Note: To power off the A/D converter, it is necessary to set ADOFF as "1".

Serial Interface Module – SIM

The device contains a Serial Interface Module, which includes both the four line SPI interface and the two line I²C interface types, to allow an easy method of communication with external peripheral hardware. Having relatively simple communication protocols, these serial interface types allow the microcontroller to interface to external SPI or I²C based hardware such as sensors, Flash memory, etc. As both interface types share the same pins and registers, the choice of whether the SPI or I²C type is used is made using the SIM operating mode control bits, named SIM2~SIM0, in the SIMC0 register. These pull-high resistors of the SIM pin-shared I/O pins are selected using pull-high control registers when the SIM function is enabled and the corresponding pins are used as SIM input pins.

SPI Interface

The SPI interface is often used to communicate with external peripheral devices such as sensors, Flash memory devices etc. Originally developed by Motorola, the four line SPI interface is a synchronous serial data interface that has a relatively simple communication protocol simplifying the programming requirements when communicating with external hardware devices.

The communication is full duplex and operates as a slave/master type, where the device can be either master or slave. Although the SPI interface specification can control multiple slave devices from a single master, but this device is provided only one \overline{SCS} pin. If the master needs to control multiple slave devices from a single master, the master can use I/O pin to select the slave devices.

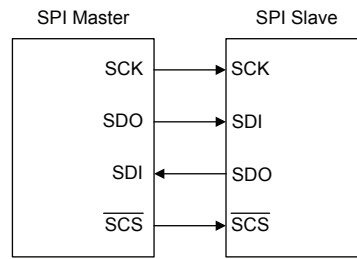

SPI Master/Slave Connection

SPI Interface Operation

The SPI interface is a full duplex synchronous serial data link. It is a four line interface with pin names SDI, SDO, SCK and \overline{SCS} . Pins SDI and SDO are the Serial Data Input and Serial Data Output lines; SCK is the Serial Clock line and \overline{SCS} is the Slave Select line. As the SPI interface pins are pin-shared with normal I/O pins and with the I²C function pins, the SPI interface must first be enabled by setting the correct bits in the SIMC0 and SIMC2 registers. The SPI can be disabled or enabled using the SIMEN bit in the SIMC0 register. Communication between devices connected to the SPI interface is carried out in a slave/master mode with all data transfer initiations being implemented by the master. The Master also controls the clock signal. As the device only contains a single \overline{SCS} pin only one slave device can be utilized. The \overline{SCS} pin is controlled by software, set CSEN bit to "1" to enable pin function, set CSEN bit to "0" the \overline{SCS} pin will be floating state.

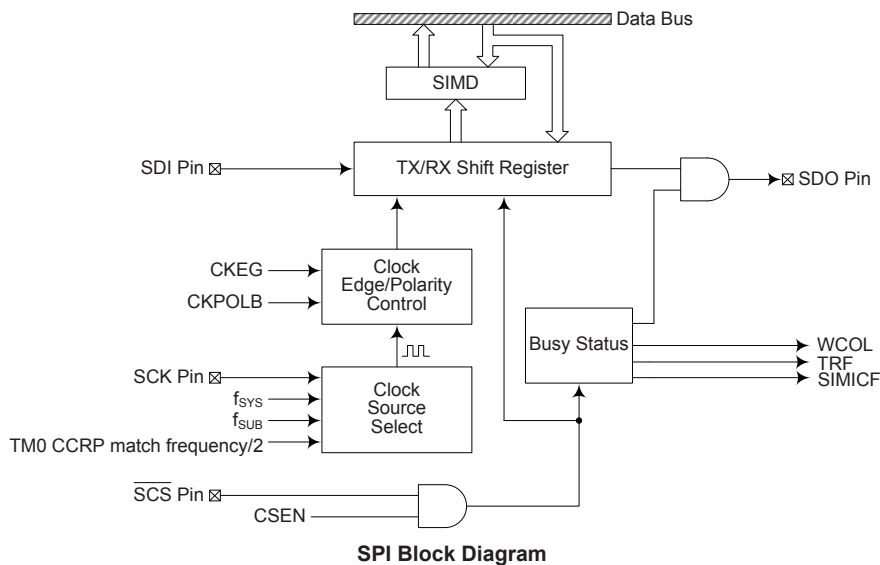

The SPI function in the device offers the following features:

- Full duplex synchronous data transfer
- Both Master and Slave modes
- LSB first or MSB first data transmission modes
- Transmission complete flag
- Rising or falling active clock edge

The status of the SPI interface pins is determined by a number of factors such as whether the device is in the master or slave mode and upon the condition of certain control bits such as CSEN and SIMEN.

SPI Registers

There are three internal registers which control the overall operation of the SPI interface. These are the SIMD data register and two registers SIMC0 and SIMC2. Note that the SIMC1 register is only used by the I²C interface.

Register Name	Bit							
	7	6	5	4	3	2	1	0
SIMC0	SIM2	SIM1	SIM0	—	SIMDEB1	SIMDEB0	SIMEN	SIMICF
SIMD	D7	D6	D5	D4	D3	D2	D1	D0
SIMC2	D7	D6	CKPOLB	CKEG	MLS	CSEN	WCOL	TRF

SIM Registers List

The SIMD register is used to store the data being transmitted and received. The same register is used by both the SPI and I²C functions. Before the device writes data to the SPI bus, the actual data to be transmitted must be placed in the SIMD register. After the data is received from the SPI bus, the device can read it from the SIMD register. Any transmission or reception of data from the SPI bus must be made via the SIMD register.

• **SIMD Register**

Bit	7	6	5	4	3	2	1	0
Name	D7	D6	D5	D4	D3	D2	D1	D0
R/W	R/W	R/W	R/W	R/W	R/W	R/W	R/W	R/W
POR	x	x	x	x	x	x	x	x

"x" unknown

There are also two control registers for the SPI interface, SIMC0 and SIMC2. Note that the SIMC2 register also has the name SIMA which is used by the I²C function. The SIMC1 register is not used by the SPI function, only by the I²C function. Register SIMC0 is used to control the enable/disable function and to set the data transmission clock frequency. Although not connected with the SPI function, the SIMC0 register is also used to control the Peripheral Clock Prescaler. Register SIMC2 is used for other control functions such as LSB/MSB selection, write collision flag etc.

• **SIMC0 Register**

Bit	7	6	5	4	3	2	1	0
Name	SIM2	SIM1	SIM0	—	SIMDEB1	SIMDEB0	SIMEN	SIMICF
R/W	R/W	R/W	R/W	—	R/W	R/W	R/W	R/W
POR	1	1	1	—	0	0	0	0

Bit 7~5 **SIM2~SIM0**: SIM Operating Mode Control

- 000: SPI master mode; SPI clock is $f_{SYS}/4$
- 001: SPI master mode; SPI clock is $f_{SYS}/16$
- 010: SPI master mode; SPI clock is $f_{SYS}/64$
- 011: SPI master mode; SPI clock is f_{SUB}
- 100: SPI master mode; SPI clock is TM0 CCRP match frequency/2
- 101: SPI slave mode
- 110: I²C slave mode
- 111: Unused mode

These bits setup the overall operating mode of the SIM function. As well as selecting if the I²C or SPI function, they are used to control the SPI Master/Slave selection and the SPI Master clock frequency. The SPI clock is a function of the system clock but can also be chosen to be sourced from the TM0 or f_{SUB} . If the SPI Slave Mode is selected then the clock will be supplied by an external Master device.

Bit 4 Unimplemented, read as "0"

Bit 3~2 **SIMDEB[1:0]**: I²C Debounce Time Selection

The SIMDEB[1:0] bits are of no use in SPI mode of SIM, please ignore these selection bits when operate in SPI mode.

Bit 1 **SIMEN**: SIM Control

- 0: Disable
- 1: Enable

The bit is the overall on/off control for the SIM interface. When the SIMEN bit is cleared to zero to disable the SIM interface, the SDI, SDO, SCK and \overline{SCS} , or SDA and SCL lines will be in a floating condition and the SIM operating current will be reduced to a minimum value. When the bit is high the SIM interface is enabled. The SIM configuration option must have first enabled the SIM interface for this bit to be effective. If the SIM is configured to operate as an SPI interface via the SIM2~SIM0 bits, the contents of the SPI control registers will remain at the previous settings when the SIMEN bit changes from low to high and should therefore be first initialised by the application program. If the SIM is configured to operate as an I²C interface via the SIM2~SIM0 bits and the SIMEN bit changes from low to high, the contents of the I²C control bits such as HTX and TXAK will remain at the previous settings and should therefore be first initialised by the application program while the relevant I²C flags such as HCF, HAAS, HBB, SRW and RXAK will be set to their default states.

Bit 0 **SIMICF**: SIM SPI Incomplete Flag
 0: SIM SPI incompleting is not occurred
 1: SIM SPI incompleting is occurred

This bit is only available when the SIM is configured to operate in an SPI slave mode. If the SPI operates in the slave mode with the SIMEN and CSEN bits both being set to 1 but the SCS line is pulled high by the external master device before the SPI data transfer is completely finished, the SIMICF bit will be set to 1 together with the TRF bit. When this condition occurs, the corresponding interrupt will occur if the interrupt function is enabled. However, the TRF bit will not be set to 1 if the SIMICF bit is set to 1 by software application program.

• **SIMC2 Register**

Bit	7	6	5	4	3	2	1	0
Name	D7	D6	CKPOLB	CKEG	MLS	CSEN	WCOL	TRF
R/W	R/W	R/W	R/W	R/W	R/W	R/W	R/W	R/W
POR	0	0	0	0	0	0	0	0

Bit 7~6 **D7~D6**: Undefined bit
 This bit can be read or written by user software program.

Bit 5 **CKPOLB**: Determines the Base Condition of the Clock Line
 0: The SCK line will be high when the clock is inactive
 1: The SCK line will be low when the clock is inactive

The CKPOLB bit determines the base condition of the clock line, if the bit is high, then the SCK line will be low when the clock is inactive. When the CKPOLB bit is low, then the SCK line will be high when the clock is inactive.

Bit 4 **CKEG**: Determines SPI SCK Active Clock Edge Type
 CKPOLB=0
 0: SCK is high base level and data capture at SCK rising edge
 1: SCK is high base level and data capture at SCK falling edge
 CKPOLB=1
 0: SCK is low base level and data capture at SCK falling edge
 1: SCK is low base level and data capture at SCK rising edge

The CKEG and CKPOLB bits are used to setup the way that the clock signal outputs and inputs data on the SPI bus. These two bits must be configured before data transfer is executed otherwise an erroneous clock edge may be generated. The CKPOLB bit determines the base condition of the clock line, if the bit is high, then the SCK line will be low when the clock is inactive. When the CKPOLB bit is low, then the SCK line will be high when the clock is inactive. The CKEG bit determines active clock edge type which depends upon the condition of CKPOLB bit.

Bit 3 **MLS**: SPI Data Shift Order
 0: LSB
 1: MSB

This is the data shift select bit and is used to select how the data is transferred, either MSB or LSB first. Setting the bit high will select MSB first and low for LSB first.

Bit 2 **CSEN**: SPI \overline{SCS} Pin Control
 0: Disable
 1: Enable

The CSEN bit is used as an enable/disable for the \overline{SCS} pin. If this bit is low, then the \overline{SCS} pin will be disabled and placed into a floating condition. If the bit is high the \overline{SCS} pin will be enabled and used as a select pin.

- Bit 1 **WCOL**: SPI Write Collision Flag
 0: No collision
 1: Collision
 The WCOL flag is used to detect if a data collision has occurred. If this bit is high it means that data has been attempted to be written to the SIMD register during a data transfer operation. This writing operation will be ignored if data is being transferred. The bit can be cleared by the application program.
- Bit 0 **TRF**: SPI Transmit/Receive Complete Flag
 0: Data is being transferred
 1: SPI data transmission is completed
 The TRF bit is the Transmit/Receive Complete flag and is set high automatically when an SPI data transmission is completed, but must be cleared to zero by the application program. It can be used to generate an interrupt.

SPI Communication

After the SPI interface is enabled by setting the SIMEN bit high, then in the Master Mode, when data is written to the SIMD register, transmission/reception will begin simultaneously. When the data transfer is complete, the TRF flag will be set automatically, but must be cleared using the application program. In the Slave Mode, when the clock signal from the master has been received, any data in the SIMD register will be transmitted and any data on the SDI pin will be shifted into the SIMD register. The master should output an \overline{SCS} signal to enable the slave device before a clock signal is provided. The slave data to be transferred should be well prepared at the appropriate moment relative to the \overline{SCS} signal depending upon the configurations of the CKPOLB bit and CKEG bit. The accompanying timing diagram shows the relationship between the slave data and \overline{SCS} signal for various configurations of the CKPOLB and CKEG bits.

The SPI will continue to function in special IDLE Modes if the clock source used by the SPI interface is still active.

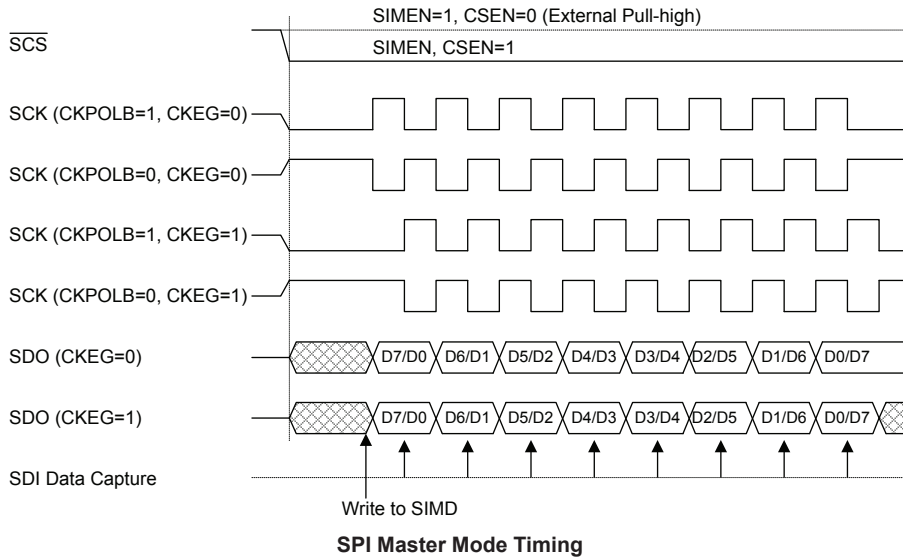

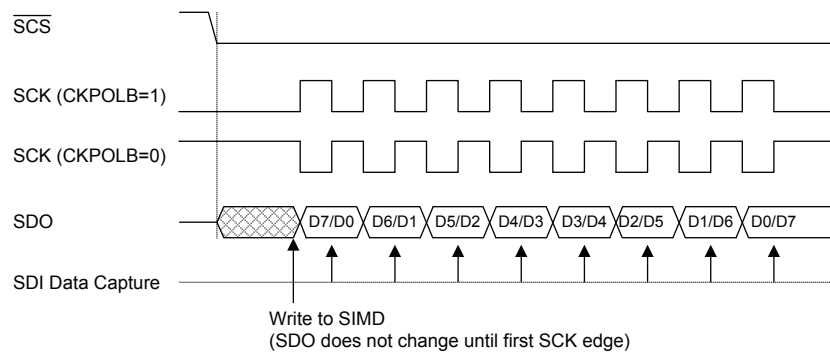

SPI Slave Mode Timing – CKEG=0

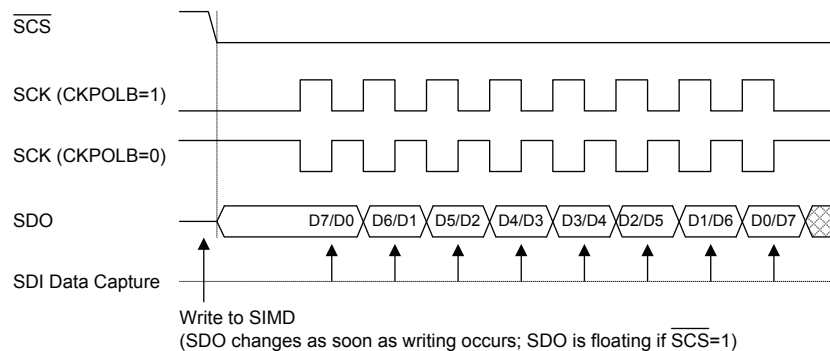

Note: For SPI slave mode, if SIMEN=1 and CSEN=0, SPI is always enabled and ignores the SCS level.

SPI Slave Mode Timing – CKEG=1

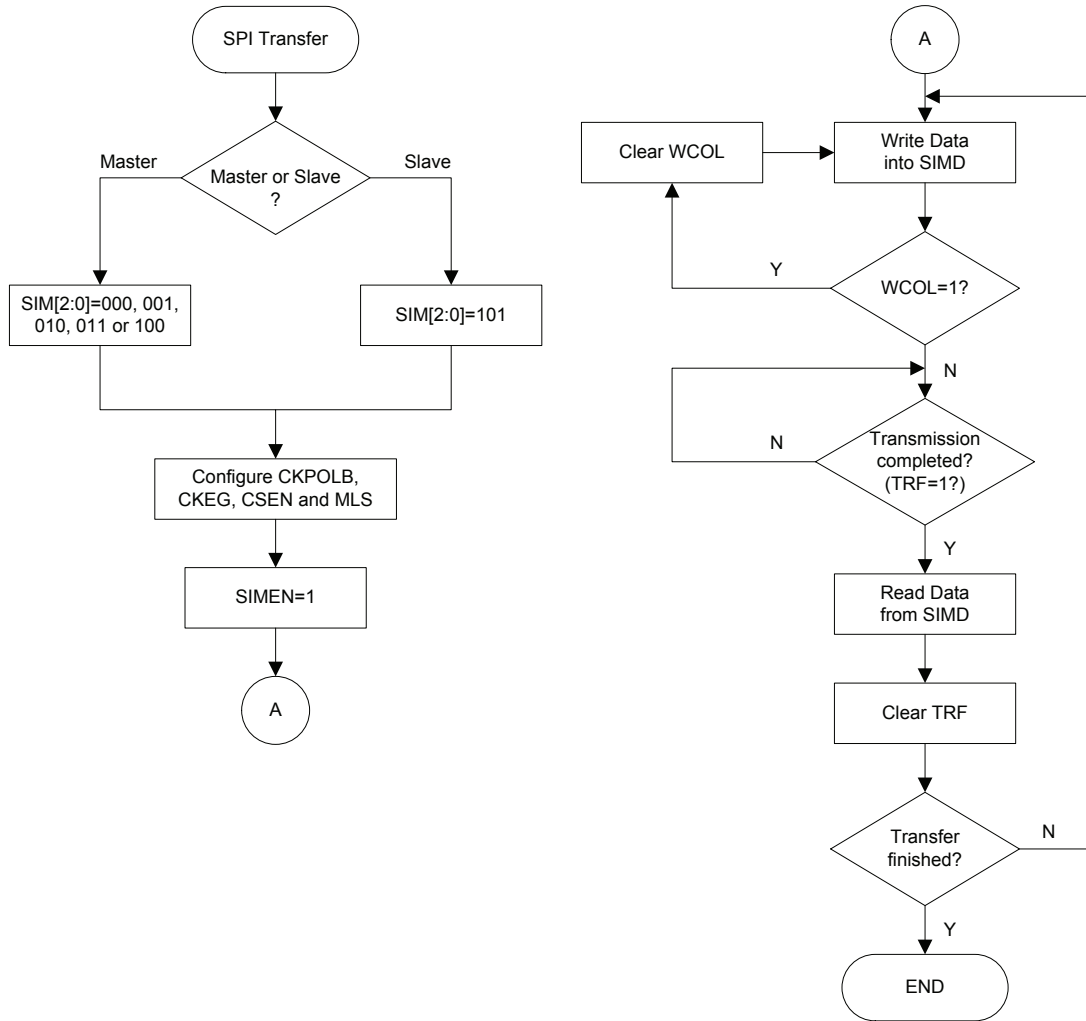

SPI Transfer Control Flowchart

SPI Bus Enable/Disable

To enable the SPI bus, set CSEN=1 and $\overline{\text{SCS}}=0$, then wait for data to be written into the SIMD (TXRX buffer) register. For the Master Mode, after data has been written to the SIMD (TXRX buffer) register, then transmission or reception will start automatically. When all the data has been transferred, the TRF bit should be set. For the Slave Mode, when clock pulses are received on SCK, data in the TXRX buffer will be shifted out or data on SDI will be shifted in.

When the SPI bus is disabled, SCK, SDI, SDO and $\overline{\text{SCS}}$ can become I/O pins or other pin-shared functions using the corresponding pin-shared control bits.

SPI Operation

All communication is carried out using the 4-line interface for either Master or Slave Mode.

The CSEN bit in the SIMC2 register controls the overall function of the SPI interface. Setting this bit high will enable the SPI interface by allowing the $\overline{\text{SCS}}$ line to be active, which can then be used to control the SPI interface. If the CSEN bit is low, the SPI interface will be disabled and the $\overline{\text{SCS}}$ line will be in a floating condition and can therefore not be used for control of the SPI interface. If the CSEN bit and the SIMEN bit in the SIMC0 are set high, this will place the SDI line in a floating condition and the SDO line high. If in Master Mode the SCK line will be either high or low depending upon the clock polarity selection bit CKPOLB in the SIMC2 register. If in Slave Mode the SCK line will be in a floating condition. If the SIMEN bit is low, then the bus will be disabled and $\overline{\text{SCS}}$, SDI, SDO and SCK will all become I/O pins or the other functions using the corresponding pin-shared control bits. In the Master Mode the Master will always generate the clock signal. The clock and data transmission will be initiated after data has been written into the SIMD register. In the Slave Mode, the clock signal will be received from an external master device for both data transmission and reception. The following sequences show the order to be followed for data transfer in both Master and Slave Mode.

• Master Mode:

- Step 1
Select the SPI Master mode and clock source using the SIM2~SIM0 bits in the SIMC0 control register.
- Step 2
Setup the CSEN bit and setup the MLS bit to choose if the data is MSB or LSB first, this setting must be the same with the Slave devices.
- Step 3
Setup the SIMEN bit in the SIMC0 control register to enable the SPI interface.
- Step 4
For write operations: write the data to the SIMD register, which will actually place the data into the TXRX buffer. Then use the SCK and $\overline{\text{SCS}}$ lines to output the data. After this, go to step5.
For read operations: the data transferred in on the SDI line will be stored in the TXRX buffer until all the data has been received at which point it will be latched into the SIMD register.
- Step 5
Check the WCOL bit if set high then a collision error has occurred so return to step 4. If equal to zero then go to the following step.
- Step 6
Check the TRF bit or wait for a SPI serial bus interrupt.
- Step 7
Read data from the SIMD register.

- Step 8
Clear TRF.
- Step 9
Go to step 4.
- **Slave Mode:**
 - Step 1
Select the SPI Slave mode using the SIM2~SIM0 bits in the SIMC0 control register
 - Step 2
Setup the CSEN bit and setup the MLS bit to choose if the data is MSB or LSB first, this setting must be the same with the Master devices.
 - Step 3
Setup the SIMEN bit in the SIMC0 control register to enable the SPI interface.
 - Step 4
For write operations: write the data to the SIMD register, which will actually place the data into the TXRX buffer. Then wait for the master clock SCK and $\overline{\text{SCS}}$ signal. After this, go to step5.
For read operations: the data transferred in on the SDI line will be stored in the TXRX buffer until all the data has been received at which point it will be latched into the SIMD register.
 - Step 5
Check the WCOL bit if set high then a collision error has occurred so return to step 4. If equal to zero then go to the following step.
 - Step 6
Check the TRF bit or wait for a SPI serial bus interrupt.
 - Step 7
Read data from the SIMD register.
 - Step 8
Clear TRF.
 - Step 9
Go to step 4.

Error Detection

The WCOL bit in the SIMC2 register is provided to indicate errors during data transfer. The bit is set by the SPI serial Interface but must be cleared by the application program. This bit indicates a data collision has occurred which happens if a write to the SIMD register takes place during a data transfer operation and will prevent the write operation from continuing.

I²C Interface

The I²C interface is used to communicate with external peripheral devices such as sensors etc. Originally developed by Philips, it is a two line low speed serial interface for synchronous serial data transfer. The advantage of only two lines for communication, relatively simple communication protocol and the ability to accommodate multiple devices on the same bus has made it an extremely popular interface type for many applications.

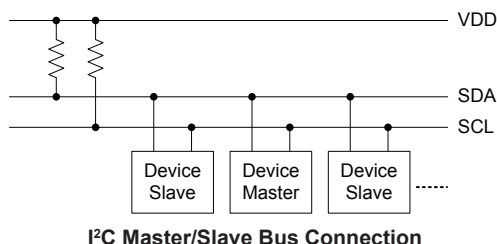

I²C Interface Operation

The I²C serial interface is a two line interface, a serial data line, SDA, and serial clock line, SCL. As many devices may be connected together on the same bus, their outputs are both open drain types. For this reason it is necessary that external pull-high resistors are connected to these outputs. Note that no chip select line exists, as each device on the I²C bus is identified by a unique address which will be transmitted and received on the I²C bus.

When two devices communicate with each other on the bidirectional I²C bus, one is known as the master device and one as the slave device. Both master and slave can transmit and receive data; however, it is the master device that has overall control of the bus. For the device, which only operate in slave mode, there are two methods of transferring data on the I²C bus, the slave transmit mode and the slave receive mode. The pull-up control function pin-shared with SCL/SDA pin is still applicable even if I²C device is activated and the related internal pull-up register could be controlled by its corresponding pull-up control register.

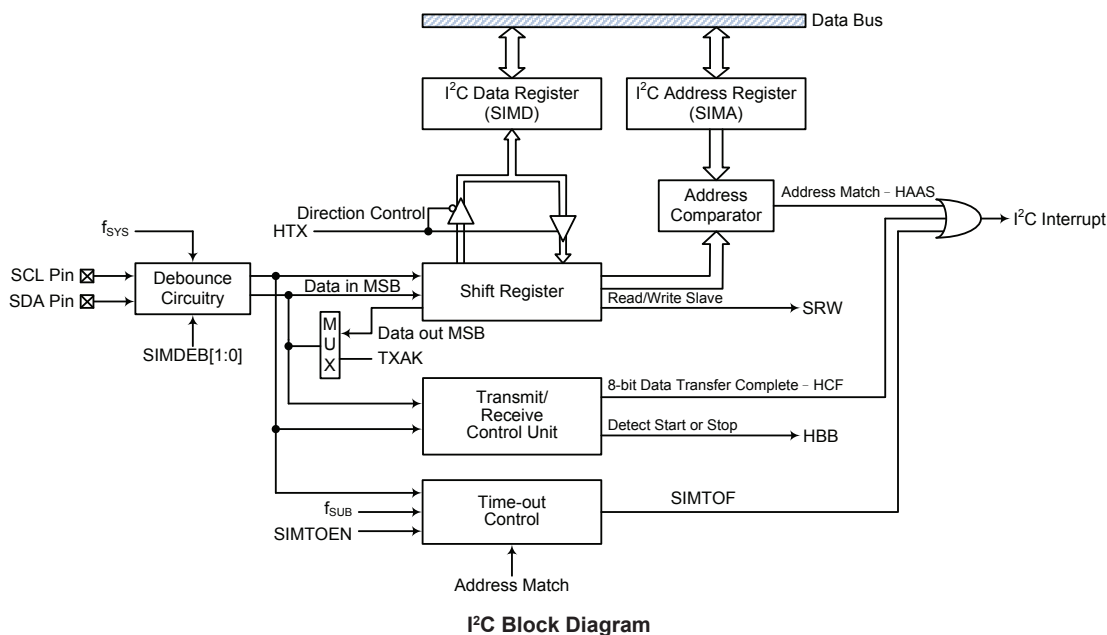

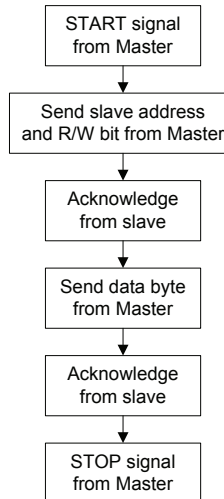

The SIMDEB1 and SIMDEB0 bits determine the debounce time of the I²C interface. This uses the internal clock to in effect add a debounce time to the external clock to reduce the possibility of glitches on the clock line causing erroneous operation. The debounce time, if selected, can be chosen to be either 2 or 4 system clocks. To achieve the required I²C data transfer speed, there exists a relationship between the system clock, f_{SYS} , and the I²C debounce time. For either the I²C Standard or Fast mode operation, users must take care of the selected system clock frequency and the configured debounce time to match the criterion shown in the following table.

I ² C Debounce Time Selection	I ² C Standard Mode (100kHz)	I ² C Fast Mode (400kHz)
No Debounce	$f_{SYS} > 2 \text{ MHz}$	$f_{SYS} > 5 \text{ MHz}$
2 system clock debounce	$f_{SYS} > 4 \text{ MHz}$	$f_{SYS} > 10 \text{ MHz}$
4 system clock debounce	$f_{SYS} > 8 \text{ MHz}$	$f_{SYS} > 20 \text{ MHz}$

I²C Minimum f_{SYS} Frequency

I²C Registers

There are three control registers associated with the I²C bus, SIMC0, SIMC1 and SIMTOC, one address register, SIMA and one data register, SIMD. The SIMD register, which is shown in the above SPI section, is also used to store the data being transmitted and received on the I²C bus. Note that the SIMA register also has the name SIMC2 which is used by the SPI function. Bit SIMEN and bits SIM2~SIM0 in register SIMC0 are used by the I²C interface. The SIMTOC register is used for I²C time-out control.

Register Name	Bit							
	7	6	5	4	3	2	1	0
SIMC0	SIM2	SIM1	SIM0	—	SIMDEB1	SIMDEB0	SIMEN	SIMICF
SIMC1	HCF	HAAS	HBB	HTX	TXAK	SRW	IAMWU	RXAK
SIMD	D7	D6	D5	D4	D3	D2	D1	D0
SIMA	A6	A5	A4	A3	A2	A1	A0	D0
SIMTOC	SIMTOEN	SIMTOF	SIMTOS5	SIMTOS4	SIMTOS3	SIMTOS2	SIMTOS1	SIMTOS0

I²C Register List

• **SIMC0 Register**

Bit	7	6	5	4	3	2	1	0
Name	SIM2	SIM1	SIM0	—	SIMDEB1	SIMDEB0	SIMEN	SIMICF
R/W	R/W	R/W	R/W	—	R/W	R/W	R/W	R/W
POR	1	1	1	—	0	0	0	0

Bit 7~5 **SIM2~SIM0**: SIM Operating Mode Control
 000: SPI master mode; SPI clock is $f_{SYS}/4$
 001: SPI master mode; SPI clock is $f_{SYS}/16$
 010: SPI master mode; SPI clock is $f_{SYS}/64$
 011: SPI master mode; SPI clock is f_{SUB}
 100: SPI master mode; SPI clock is TM0 CCRP match frequency/2
 101: SPI slave mode
 110: I²C slave mode
 111: Unused mode

These bits setup the overall operating mode of the SIM function. As well as selecting if the I²C or SPI function, they are used to control the SPI Master/Slave selection and the SPI Master clock frequency. The SPI clock is a function of the system clock but can also be chosen to be sourced from the TM0 or f_{SUB} . If the SPI Slave Mode is selected then the clock will be supplied by an external Master device.

Bit 4 Unimplemented, read as "0"

Bit 3~2 **SIMDEB1~SIMDEB0**: I²C Debounce Time Selection
 00: No debounce
 01: 2 system clock debounce
 1x: 4 system clock debounce

Bit 1 **SIMEN**: SIM Control
 0: Disable
 1: Enable

The bit is the overall on/off control for the SIM interface. When the SIMEN bit is cleared to zero to disable the SIM interface, the SDI, SDO, SCK and \overline{SCS} , or SDA and SCL lines will be in a floating condition and the SIM operating current will be reduced to a minimum value. When the bit is high the SIM interface is enabled. The SIM configuration option must have first enabled the SIM interface for this bit to be effective. If the SIM is configured to operate as an SPI interface via the SIM2~SIM0 bits, the contents of the SPI control registers will remain at the previous settings when the SIMEN bit changes from low to high and should therefore be first initialised by the application program. If the SIM is configured to operate as an I²C interface via the SIM2~SIM0 bits and the SIMEN bit changes from low to high, the contents of the I²C control bits such as HTX and TXAK will remain at the previous settings and should therefore be first initialised by the application program while the relevant I²C flags such as HCF, HAAS, HBB, SRW and RXAK will be set to their default states.

Bit 0 **SIMICF**: SIM SPI Incomplete Flag
 SIMICF is of no use in I²C mode of SIM, please ignore this flag when operate in I²C mode.

• **SIMC1 Register**

Bit	7	6	5	4	3	2	1	0
Name	HCF	HAAS	HBB	HTX	TXAK	SRW	IAMWU	RXAK
R/W	R	R	R	R/W	R/W	R	R/W	R
POR	1	0	0	0	0	0	0	1

Bit 7 **HCF**: I²C Bus Data Transfer Completion Flag
 0: Data is being transferred
 1: Completion of an 8-bit data transfer

The HCF flag is the data transfer flag. This flag will be zero when data is being transferred. Upon completion of an 8-bit data transfer the flag will go high and an interrupt will be generated.

- Bit 6 **HAAS:** I²C Bus Address Match Flag
 0: Not address match
 1: Address match
 The HAAS flag is the address match flag. This flag is used to determine if the slave device address is the same as the master transmit address. If the addresses match then this bit will be high, if there is no match then the flag will be low.
- Bit 5 **HBB:** I²C Bus Busy Flag
 0: I²C Bus is not busy
 1: I²C Bus is busy
 The HBB flag is the I²C busy flag. This flag will be "1" when the I²C bus is busy which will occur when a START signal is detected. The flag will be cleared to zero when the bus is free which will occur when a STOP signal is detected.
- Bit 4 **HTX:** Select I²C Slave Device is Transmitter or Receiver
 0: Slave device is the receiver
 1: Slave device is the transmitter
- Bit 3 **TXAK:** I²C Bus Transmit Acknowledge Flag
 0: Slave send acknowledge flag
 1: Slave do not send acknowledge flag
 The TXAK bit is the transmit acknowledge flag. After the slave device receipt of 8-bit of data, this bit will be transmitted to the bus on the 9th clock from the slave device. The slave device must always set TXAK bit to "0" before further data is received.
- Bit 2 **SRW:** I²C Slave Read/Write Flag
 0: Slave device should be in receive mode
 1: Slave device should be in transmit mode
 The SRW flag is the I²C Slave Read/Write flag. This flag determines whether the master device wishes to transmit or receive data from the I²C bus. When the transmitted address and slave address is match, that is when the HAAS flag is set high, the slave device will check the SRW flag to determine whether it should be in transmit mode or receive mode. If the SRW flag is high, the master is requesting to read data from the bus, so the slave device should be in transmit mode. When the SRW flag is zero, the master will write data to the bus, therefore the slave device should be in receive mode to read this data.
- Bit 1 **IAMWU:** I²C Address Match Wake Up Function Control
 0: Disable
 1: Enable.
 This bit should be set to 1 to enable the I²C address match wake up from the SLEEP or IDLE Mode. If the IAMWU bit has been set before entering either the SLEEP or IDLE mode to enable the I²C address match wake up, then this bit must be cleared by the application program after wake-up to ensure correct device operation.
- Bit 0 **RXAK:** I²C Bus Receive Acknowledge Flag
 0: Slave receives acknowledge flag
 1: Slave does not receive acknowledge flag
 The RXAK flag is the receiver acknowledge flag. When the RXAK flag is "0", it means that a acknowledge signal has been received at the 9th clock, after 8 bits of data have been transmitted. When the slave device in the transmit mode, the slave device checks the RXAK flag to determine if the master receive wishes to receive the next byte. The slave transmitter will therefore continue sending out data until the RXAK flag is "1". When this occurs, the slave transmitter will release the SDA line to allow the master to send a STOP signal to release the I²C bus.

The SIMD register is used to store the data being transmitted and received. The same register is used by both the SPI and I²C functions. Before the device write data to the I²C bus, the actual data to be transmitted must be placed in the SIMD register. After the data is received from the I²C bus, the device can read it from the SIMD register. Any transmission or reception of data from the I²C bus must be made via the SIMD register.

• **SIMD Register**

Bit	7	6	5	4	3	2	1	0
Name	D7	D6	D5	D4	D3	D2	D1	D0
R/W	R/W	R/W	R/W	R/W	R/W	R/W	R/W	R/W
POR	x	x	x	x	x	x	x	x

"x" unknown

• **SIMA Register**

Bit	7	6	5	4	3	2	1	0
Name	A6	A5	A4	A3	A2	A1	A0	D0
R/W	R/W	R/W	R/W	R/W	R/W	R/W	R/W	R/W
POR	0	0	0	0	0	0	0	0

Bit 7~1 **A6~A0**: I²C Slave address

A6~A0 is the I²C slave address bit 6 ~ bit 0.

The SIMA register is also used by the SPI interface but has the name SIMC2. The SIMA register is the location where the 7-bit slave address of the slave device is stored. Bit 7~Bit 1 of the SIMA register define the device slave address. Bit 0 is not defined.

When a master device, which is connected to the I²C bus, sends out an address, which matches the slave address in the SIMA register, the slave device will be selected. Note that the SIMA register is the same register address as SIMC2 which is used by the SPI interface.

Bit 0 **D0**: Undefined bit

This bit can be read or written by user software program.

• **SIMTOC Register**

Bit	7	6	5	4	3	2	1	0
Name	SIMTOEN	SIMTOF	SIMTOS5	SIMTOS4	SIMTOS3	SIMTOS2	SIMTOS1	SIMTOS0
R/W	R/W	R/W	R/W	R/W	R/W	R/W	R/W	R/W
POR	0	0	0	0	0	0	0	0

Bit 7 **SIMTOEN**: I²C interface Time-out control

0: Disable
 1: Enable

Bit 6 **SIMTOF**: I²C interface Time-out flag

0: No occurred
 1: Occurred

The SIMTOF flag is set by the time-out circuitry when the time-out event occurs and cleared by software program.

Bit 5~0 **SIMTOS5~SIMTOS0**: I²C interface Time-out period selection

The I²C Time-Out clock source is $f_{SUB}/32$.

The I²C Time-Out time is $([SIMTOS5:SIMTOS0] + 1) \times (32/f_{SUB})$

I²C Bus Communication

Communication on the I²C bus requires four separate steps, a START signal, a slave device address transmission, a data transmission and finally a STOP signal. When a START signal is placed on the I²C bus, all devices on the bus will receive this signal and be notified of the imminent arrival of data on the bus. The first seven bits of the data will be the slave address with the first bit being the MSB. If the address of the slave device matches that of the transmitted address, the HAAS bit in the SIMC1 register will be set and an I²C interrupt will be generated. After entering the interrupt service routine, the slave device must first check the condition of the HAAS bit and SIMTOF bit to determine whether the interrupt source originates from an address match or from the completion of an 8-bit data transfer or from the I²C communication time-out. During a data transfer, note that after the 7-bit slave address has been transmitted, the following bit, which is the 8th bit, is the read/write bit whose value will be placed in the SRW bit. This bit will be checked by the slave device to determine whether to go into transmit or receive mode. Before any transfer of data to or from the I²C bus, the microcontroller must initialise the bus, the following are steps to achieve this:

- Step 1
 Set the SIM2~SIM0 bits to "110" and the SIMEN bits to "1" in the SIMC0 register to enable the I²C bus.
- Step 2
 Write the slave address to the I²C bus address register SIMA.
- Step 3
 Set the interrupt enable bit SIME to enable the SIM interrupt.

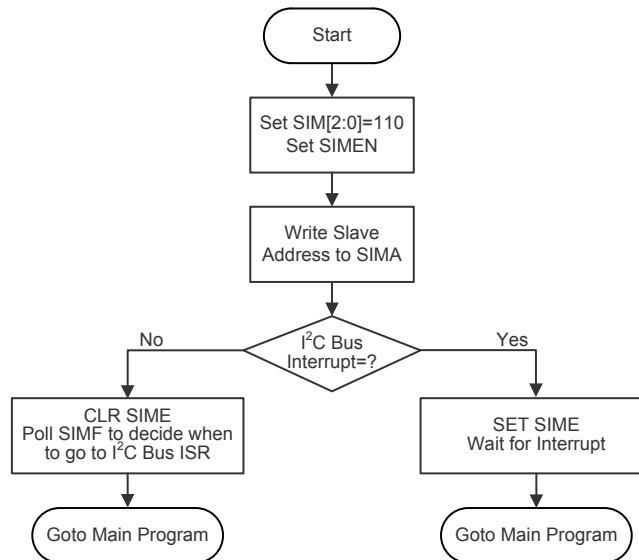

I²C Bus Initialisation Flow Chart

I²C Bus Start Signal

The START signal can only be generated by the master device connected to the I²C bus and not by the slave device. This START signal will be detected by all devices connected to the I²C bus. When detected, this indicates that the I²C bus is busy and therefore the HBB bit will be set. A START condition occurs when a high to low transition on the SDA line takes place when the SCL line remains high.

Slave Address

The transmission of a START signal by the master will be detected by all devices on the I²C bus. To determine which slave device the master wishes to communicate with, the address of the slave device will be sent out immediately following the START signal. All slave devices, after receiving this 7-bit address data, will compare it with their own 7-bit slave address. If the address sent out by the master matches the internal address of the microcontroller slave device, then an internal I²C bus interrupt signal will be generated. The next bit following the address, which is the 8th bit, defines the read/write status and will be saved to the SRW bit of the SIMC1 register. The slave device will then transmit an acknowledge bit, which is a low level, as the 9th bit. The slave device will also set the status flag HAAS when the addresses match.

As an I²C bus interrupt can come from three sources, when the program enters the interrupt subroutine, the HAAS bit and SIMTOF bit should be examined to see whether the interrupt source has come from a matching slave address or from the completion of a data byte transfer or from the I²C communication time-out. When a slave address is matched, the device must be placed in either the transmit mode and then write data to the SIMD register, or in the receive mode where it must implement a dummy read from the SIMD register to release the SCL line.

I²C Bus Read/Write Signal

The SRW bit in the SIMC1 register defines whether the master device wishes to read data from the I²C bus or write data to the I²C bus. The slave device should examine this bit to determine if it is to be a transmitter or a receiver. If the SRW flag is "1" then this indicates that the master device wishes to read data from the I²C bus, therefore the slave device must be setup to send data to the I²C bus as a transmitter. If the SRW flag is "0" then this indicates that the master wishes to send data to the I²C bus, therefore the slave device must be setup to read data from the I²C bus as a receiver.

I²C Bus Slave Address Acknowledge Signal

After the master has transmitted a calling address, any slave device on the I²C bus, whose own internal address matches the calling address, must generate an acknowledge signal. The acknowledge signal will inform the master that a slave device has accepted its calling address. If no acknowledge signal is received by the master then a STOP signal must be transmitted by the master to end the communication. When the HAAS flag is high, the addresses have matched and the slave device must check the SRW flag to determine if it is to be a transmitter or a receiver. If the SRW flag is high, the slave device should be setup to be a transmitter so the HTX bit in the SIMC1 register should be set high. If the SRW flag is low, then the microcontroller slave device should be setup as a receiver and the HTX bit in the SIMC1 register should be cleared to zero.

I²C Bus Data and Acknowledge Signal

The transmitted data is 8-bit wide and is transmitted after the slave device has acknowledged receipt of its slave address. The order of serial bit transmission is the MSB first and the LSB last. After receipt of 8-bit of data, the receiver must transmit an acknowledge signal, level "0", before it can receive the next data byte. If the slave transmitter does not receive an acknowledge bit signal from the master receiver, then the slave transmitter will release the SDA line to allow the master to send a STOP signal to release the I²C Bus. The corresponding data will be stored in the SIMD register. If setup as a transmitter, the slave device must first write the data to be transmitted into the SIMD register. If setup as a receiver, the slave device must read the transmitted data from the SIMD register.

When the slave receiver receives the data byte, it must generate an acknowledge bit, known as TXAK, on the 9th clock. The slave device, which is setup as a transmitter will check the RXAK bit in the SIMC1 register to determine if it is to send another data byte, if not then it will release the SDA line and await the receipt of a STOP signal from the master.

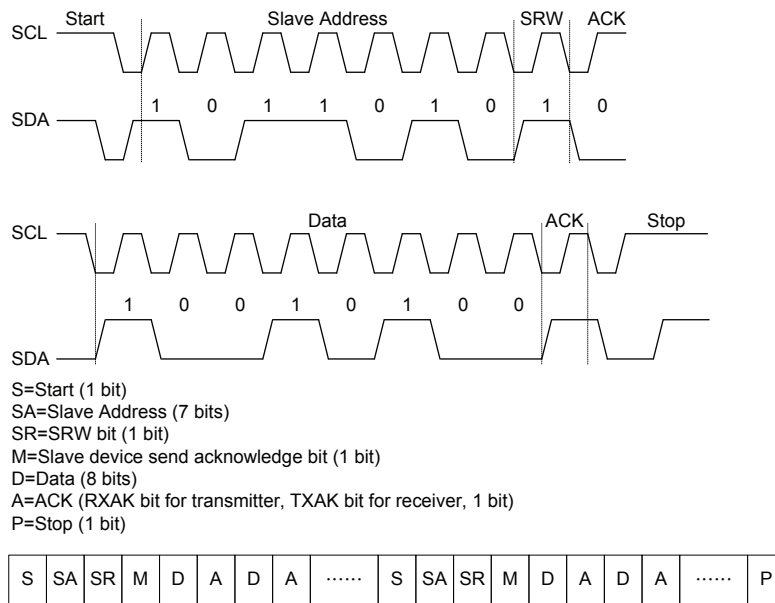

I²C Communication Timing Diagram

Note: *When a slave address is matched, the device must be placed in either the transmit mode and then write data to the SIMD register, or in the receive mode where it must implement a dummy read from the SIMD register to release the SCL line.

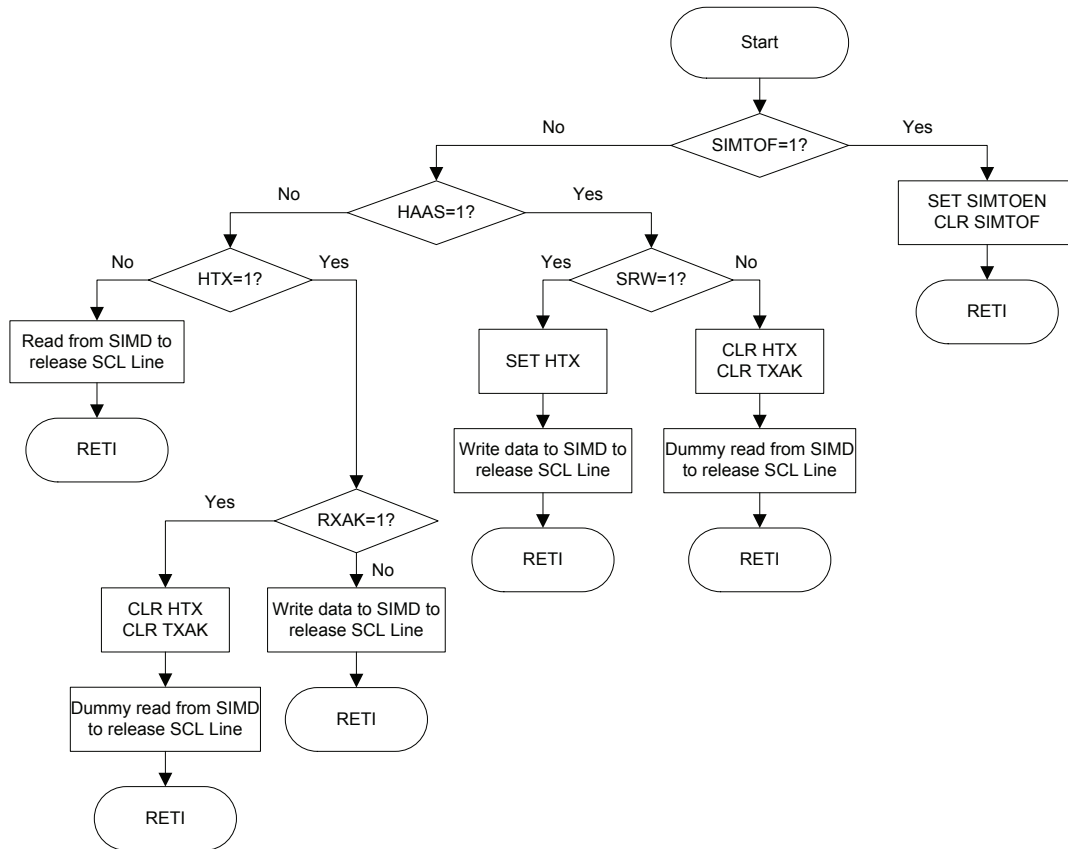

I²C Bus ISR Flow Chart

I²C Time-out Function

In order to reduce the I²C lockup problem due to reception of erroneous clock sources, a time-out function is provided. If the clock source connected to the I²C bus is not received for a while, then the I²C circuitry and the SIMC1 register will be reset, the SIMTOF bit in the SIMTOC register will be set high after a certain time-out period. The Time Out function enable/disable and the time-out period are managed by the SIMTOC register.

I²C Time Out Operation

The time-out counter starts to count on an I²C bus "START" & "address match" condition, and is cleared by an SCL falling edge. Before the next SCL falling edge arrives, if the time elapsed is greater than the time-out period specified by the SIMTOC register, then a time-out condition will occur. The time-out function will stop when an I²C "STOP" condition occurs. There are 64 time-out period selections which can be selected using the SIMTOS0~SIMTOS5 bits in the SIMTOC register.

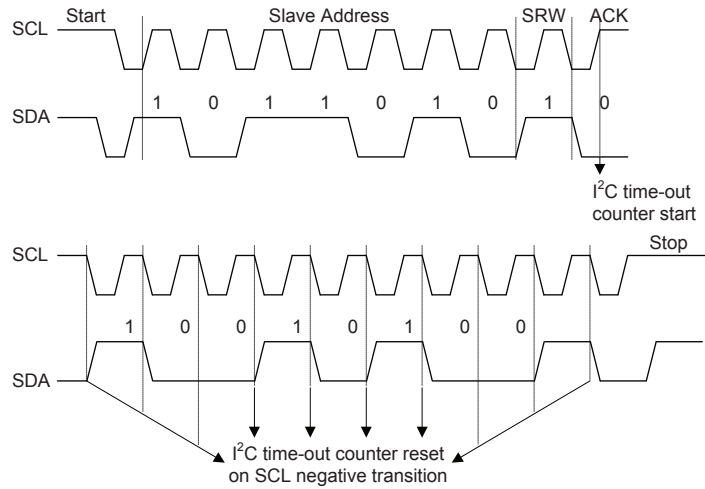

I²C Time-out Diagram

When an I²C time-out counter overflow occurs, the counter will stop and the SIMTOEN bit will be cleared to zero and the SIMTOF bit will be set high to indicate that a time-out condition has occurred. When an I²C time-out occurs, the I²C internal circuitry will be reset and the registers will be reset into the following condition:

Registers	After I ² C Time-out
SIMD, SIMA, SIMC0	No change
SIMC1	Reset to POR condition

I²C Registers after Time-out

LCD Display Memory

The device provides an area of embedded data memory for LCD display. This area is located from 80H to 9FH of the RAM at Sector 1. The Memory Pointer MP1H is the switch between the RAM and the LCD display memory. When the MP1H=01H, data written into 80H~9FH will affect the LCD display. When the MP1H is written with values other than 01H, any data written into 80H~9FH is meant to access the general purpose data memory.

The LCD display memory can be read and written to by indirect addressing mode using MP1L and MP1H. When data is written into the display data area, it is automatically read by the LCD driver which then generates the corresponding LCD driving signals. To turn the display on or off, a "1" or a "0" is written to the corresponding bit of the display memory, respectively. The figure illustrates the mapping between the display memory and LCD pattern for the device.

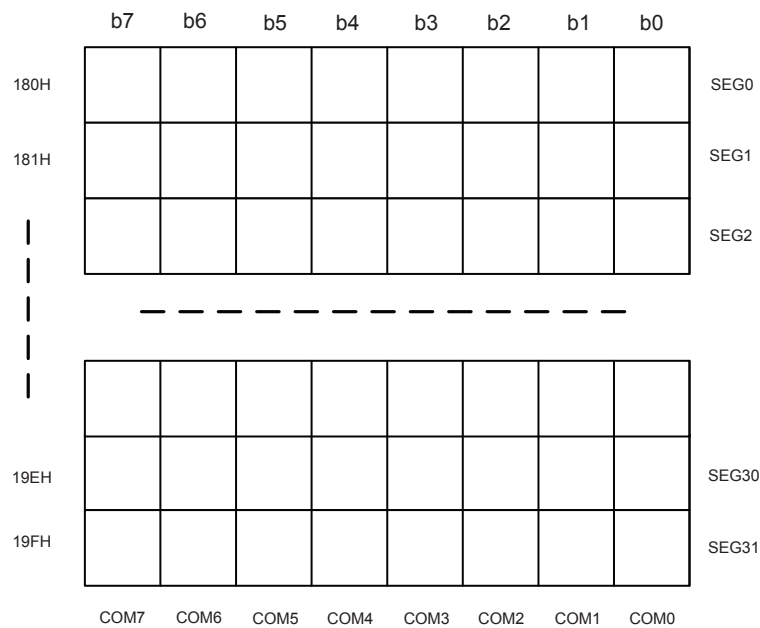

LCD Driver Output

The output number of the device LCD driver can be 32×4/32×8 or 28×4/28×8. The LCD driver is "R" type only. The LCD clock source is from f_{SUB} , which can be either the LXT or LIRC oscillator.

LCD Control Register

LCDC0 Register

Bit	7	6	5	4	3	2	1	0
Name	LCDEN	TYPE	DTYC	BIAS	—	RSEL2	RSEL1	RSEL0
R/W	R/W	R/W	R/W	R/W	—	R/W	R/W	R/W
POR	0	0	0	0	—	0	0	0

- Bit 7 **LCDEN**: LCD enable/disable control
 0: Disable
 1: Enable
 Note that the LCD driver and A/D converter should not be enabled simultaneously when the LCD output and A/D channel are shared with the same pin.
- Bit 6 **TYPE**: LCD Waveform Type selection
 0: Type A
 1: Type B
- Bit 5 **DTYC**: Define LCD Duty
 0: 1/4 Duty (LCD COM: COM0~COM3)
 1: 1/8 Duty (LCD COM: COM0~COM7)
 Note: If DTYC=1, then COM4~COM7 pins will be configured as LCD COM.
 If DTYC=0, then COM4~COM7 pins will be configured as I/O.
- Bit 4 **BIAS**: Define LCD Bias
 0: 1/3 Bias
 1: 1/4 Bias
- Bit 3 Unimplemented, read as "0"
- Bit 2~0 **RSEL2~RSEL0**: Total Bias Resistor R_T selection
 000: 1170K
 001: 225K
 010: 60K
 011: Quick Charging Mode, switch between 60K and 1170K.
 1xx: Quick Charging Mode, switch between 60K and 225K.
 Note: The bias resistor for 1/3 bias is $R_T/3$, 1/4 bias is $R_T/4$.
 The devices provide low power quick charging mode for LCD display. In quick charging mode, the LCD will provide LCD bias current by $R_T=60K$, at beginning of LCD display refreshes (i.e the moment on LCD COM changes). After quick charging time, the bias resistor will change to 225K/1170K.

LCDC1 Register

Bit	7	6	5	4	3	2	1	0
Name	QCT2	QCT1	QCT0	—	VLCD3	VLCD2	VLCD1	VLCD0
R/W	R/W	R/W	R/W	—	R/W	R/W	R/W	R/W
POR	0	0	0	—	0	0	0	0

- Bit 7 **QCT2~QCT0**: Quick charging time selection
 000: $1 \times t_{SUB}$
 001: $2 \times t_{SUB}$
 010: $3 \times t_{SUB}$
 011: $4 \times t_{SUB}$
 100: $5 \times t_{SUB}$
 101: $6 \times t_{SUB}$
 110: $7 \times t_{SUB}$
 111: $8 \times t_{SUB}$
 $t_{SUB}=1/f_{SUB}$
- Bit 6 ~ 4 Unimplemented, read as "0"

Bit 3 ~ 0 **VLCD3~VLCD0**: VLCD selection
 0000: 8/16×V_{DD}
 0001: 9/16×V_{DD}
 0010: 10/16×V_{DD}
 0011: 11/16×V_{DD}
 0100: 12/16×V_{DD}
 0101: 13/16×V_{DD}
 0110: 14/16×V_{DD}
 0111: 15/16×V_{DD}
 1000~1111: 16/16×V_{DD}

SEGCR0 Register

Bit	7	6	5	4	3	2	1	0
Name	SEG7C	SEG6C	SEG5C	SEG4C	SEG3C	SEG2C	SEG1C	SEG0C
R/W	R/W	R/W	R/W	R/W	R/W	R/W	R/W	R/W
POR	1	1	1	1	1	1	1	1

Bit 7 **SEG7C**: Select SEG7 or PD7
 0: SEG7
 1: PD7

Bit 6 **SEG6C**: Select SEG6 or PD6
 0: SEG6
 1: PD6

Bit 5 **SEG5C**: Select SEG5 or PD5
 0: SEG5
 1: PD5

Bit 4 **SEG4C**: Select SEG4 or PD4
 0: SEG4
 1: PD4

Bit 3 **SEG3C**: Select SEG3 or PD3
 0: SEG3
 1: PD3

Bit 2 **SEG2C**: Select SEG2 or PD2
 0: SEG2
 1: PD2

Bit 1 **SEG1C**: Select SEG1 or PD1
 0: SEG1
 1: PD1

Bit 0 **SEG0C**: Select SEG0 or PD0
 0: SEG0
 1: PD0

SEGCR1 Register

Bit	7	6	5	4	3	2	1	0
Name	SEG15C	SEG14C	SEG13C	SEG12C	SEG11C	SEG10C	SEG9C	SEG8C
R/W	R/W	R/W	R/W	R/W	R/W	R/W	R/W	R/W
POR	1	1	1	1	1	1	1	1

Bit 7 **SEG15C**: Select SEG15 or PC7
 0: SEG15
 1: PC7

Bit 6 **SEG14C**: Select SEG14 or PC6
 0: SEG14
 1: PC6

- Bit 5 **SEG13C**: Select SEG13 or PC5
 0: SEG13
 1: PC5
- Bit 4 **SEG12C**: Select SEG12 or PC4
 0: SEG12
 1: PC4
- Bit 3 **SEG11C**: Select SEG11 or PC3
 0: SEG11
 1: PC3
- Bit 2 **SEG10C**: Select SEG10 or PC2
 0: SEG10
 1: PC2
- Bit 1 **SEG9C**: Select SEG9 or PC1
 0: SEG9
 1: PC1
- Bit 0 **SEG8C**: Select SEG8 or PC0
 0: SEG8
 1: PC0

SEGCR2 Register

Bit	7	6	5	4	3	2	1	0
Name	SEG23C	SEG22C	SEG21C	SEG20C	SEG19C	SEG18C	SEG17C	SEG16C
R/W	R/W	R/W	R/W	R/W	R/W	R/W	R/W	R/W
POR	1	1	1	1	1	1	1	1

- Bit 7 **SEG23C**: Select SEG23 or PG1
 0: SEG23
 1: PG1
- Bit 6 **SEG22C**: Select SEG22 or PG0
 0: SEG22
 1: PG0
- Bit 5 **SEG21C**: Select SEG21 or PA2
 0: SEG21
 1: PA2
- Bit 4 **SEG20C**: Select SEG20 or PA0
 0: SEG20
 1: PA0
- Bit 3 **SEG19C**: Select SEG19 or PF7
 0: SEG19
 1: PF7
- Bit 2 **SEG18C**: Select SEG18 or PF6
 0: SEG18
 1: PF6
- Bit 1 **SEG17C**: Select SEG17 or PF5
 0: SEG17
 1: PF5
- Bit 0 **SEG16C**: Select SEG16 or PF4
 0: SEG16
 1: PF4

SEGCR3 Register

Bit	7	6	5	4	3	2	1	0
Name	SEG31C	SEG30C	SEG29C	SEG28C	SEG27C	SEG26C	SEG25C	SEG24C
R/W	R/W	R/W	R/W	R/W	R/W	R/W	R/W	R/W
POR	1	1	1	1	1	1	1	1

- Bit 7 **SEG31C**: Select SEG31 or PG7
 0: SEG31
 1: PG7
- Bit 6 **SEG30C**: Select SEG30 or PG6
 0: SEG30
 1: PG6
- Bit 5 **SEG29C**: Select SEG29 or PG5
 0: SEG29
 1: PG5
- Bit 4 **SEG28C**: Select SEG28 or PG4
 0: SEG28
 1: PG4
- Bit 3 **SEG27C**: Select SEG27 or PA7
 0: SEG27
 1: PA7
- Bit 2 **SEG26C**: Select SEG26 or PG3
 0: SEG26
 1: PG3
- Bit 1 **SEG25C**: Select SEG25 or PG2
 0: SEG25
 1: PG2
- Bit 0 **SEG24C**: Select SEG24 or PA6
 0: SEG24
 1: PA6

LCD Waveform

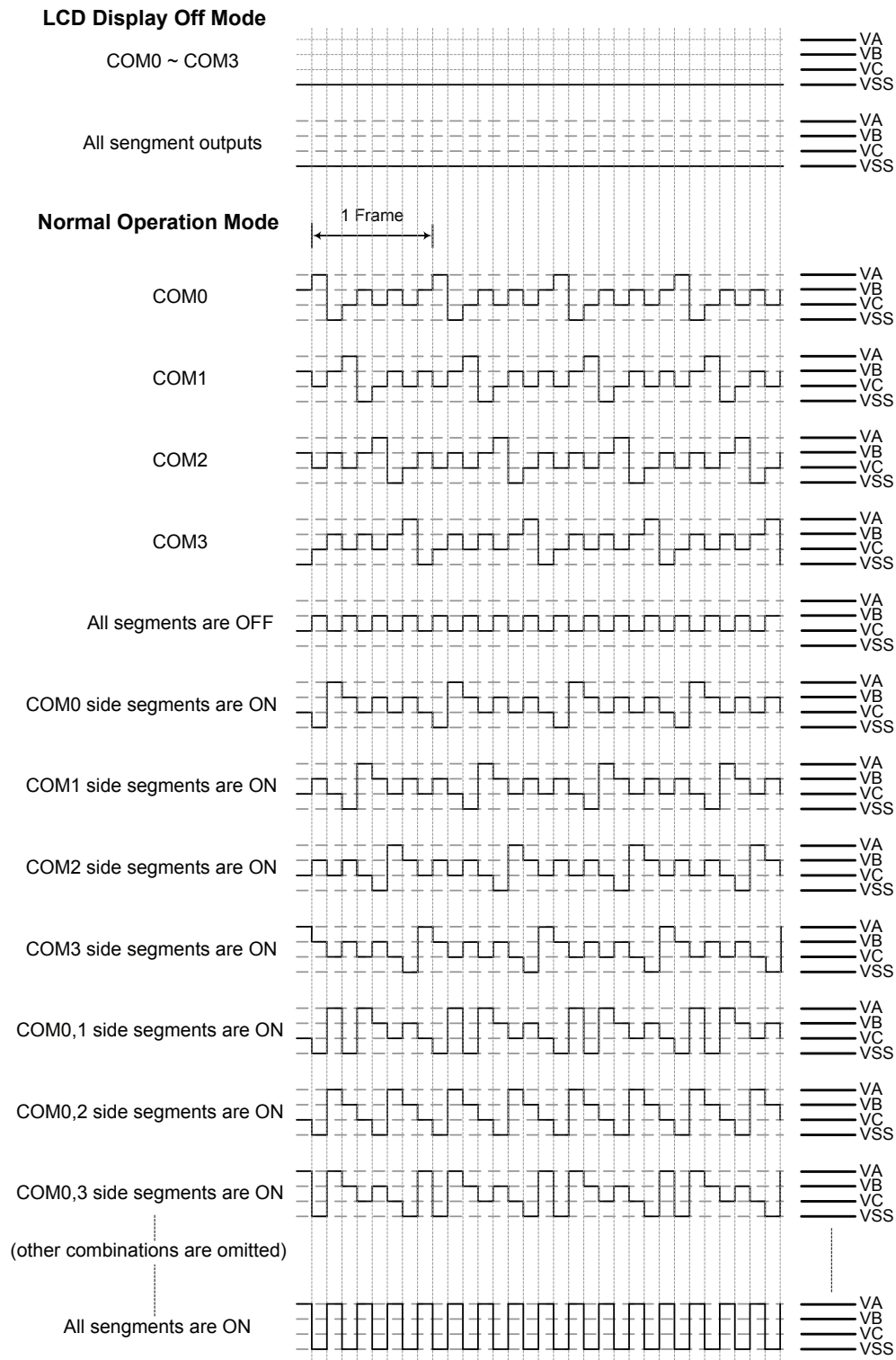

LCD Driver Output – Type A - 1/4 Duty, 1/3 Bias

Note: $V_A = V_{LCD}$, $V_B = V_{LCD} \times 2/3$ and $V_C = V_{LCD} \times 1/3$.

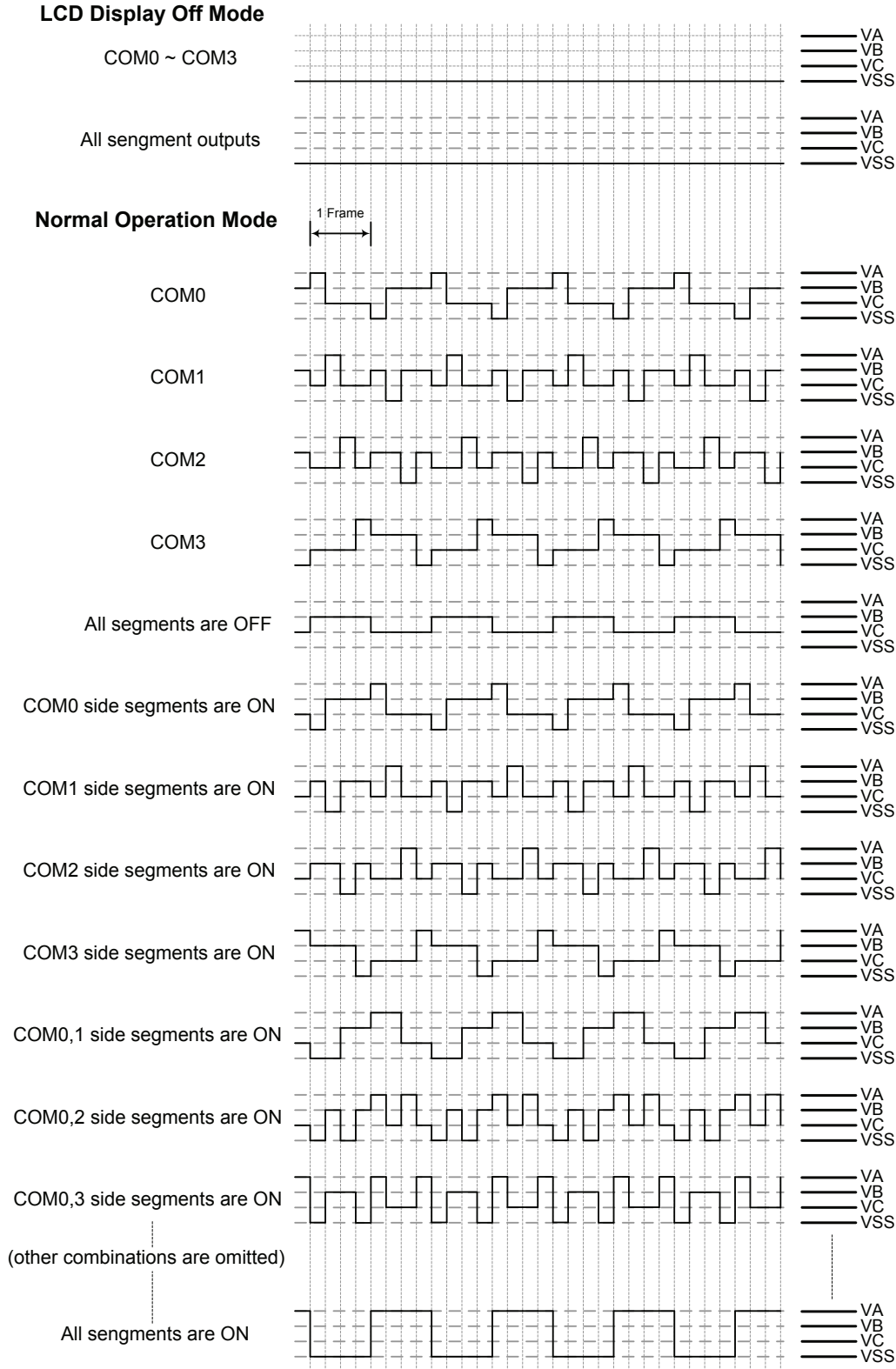

LCD Driver Output – Type B - 1/4 Duty, 1/3 Bias

Note: $V_A = V_{LCD}$, $V_B = V_{LCD} \times 2/3$ and $V_C = V_{LCD} \times 1/3$.

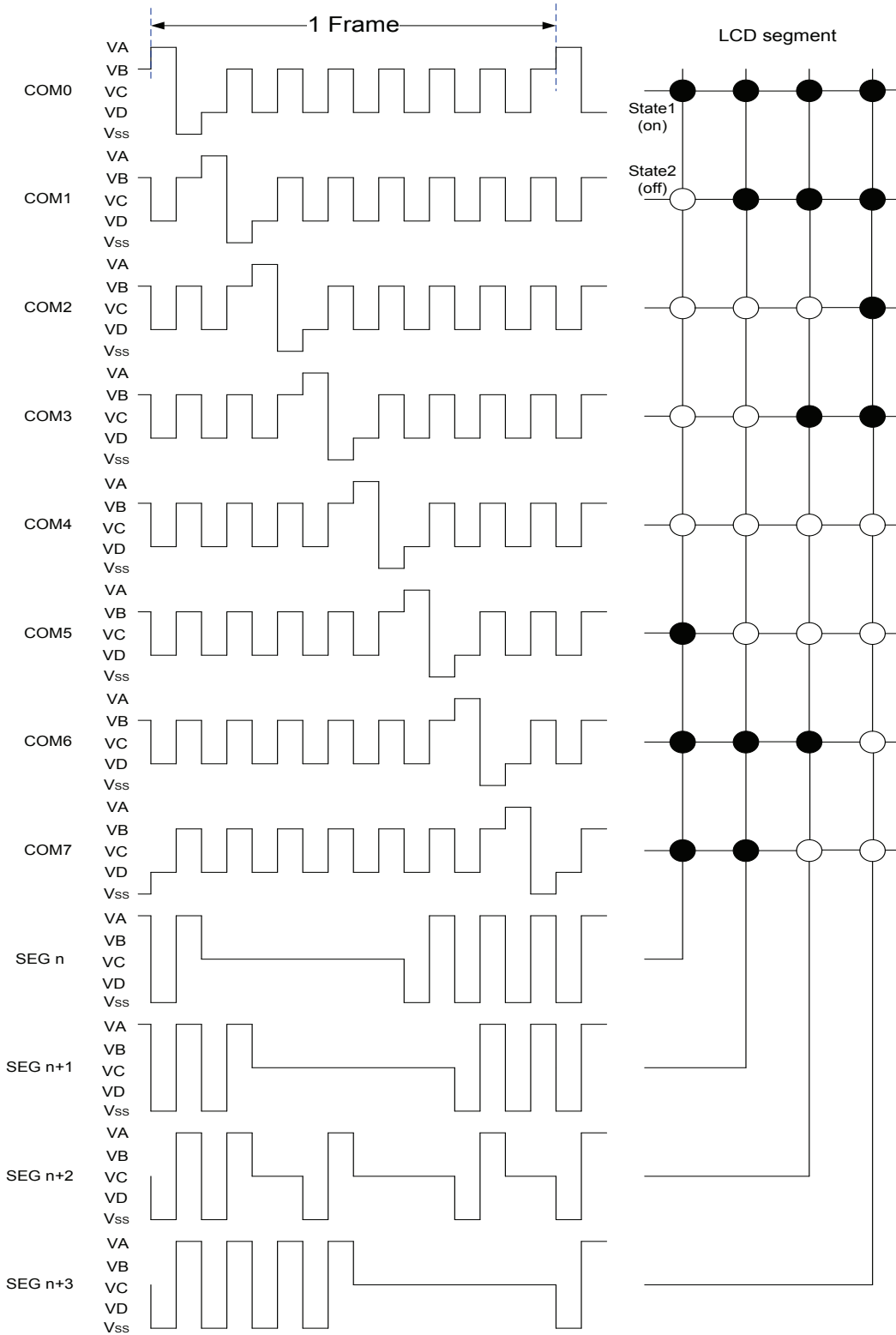

LCD Driver Output – Type A - 1/8 Duty, 1/4 Bias

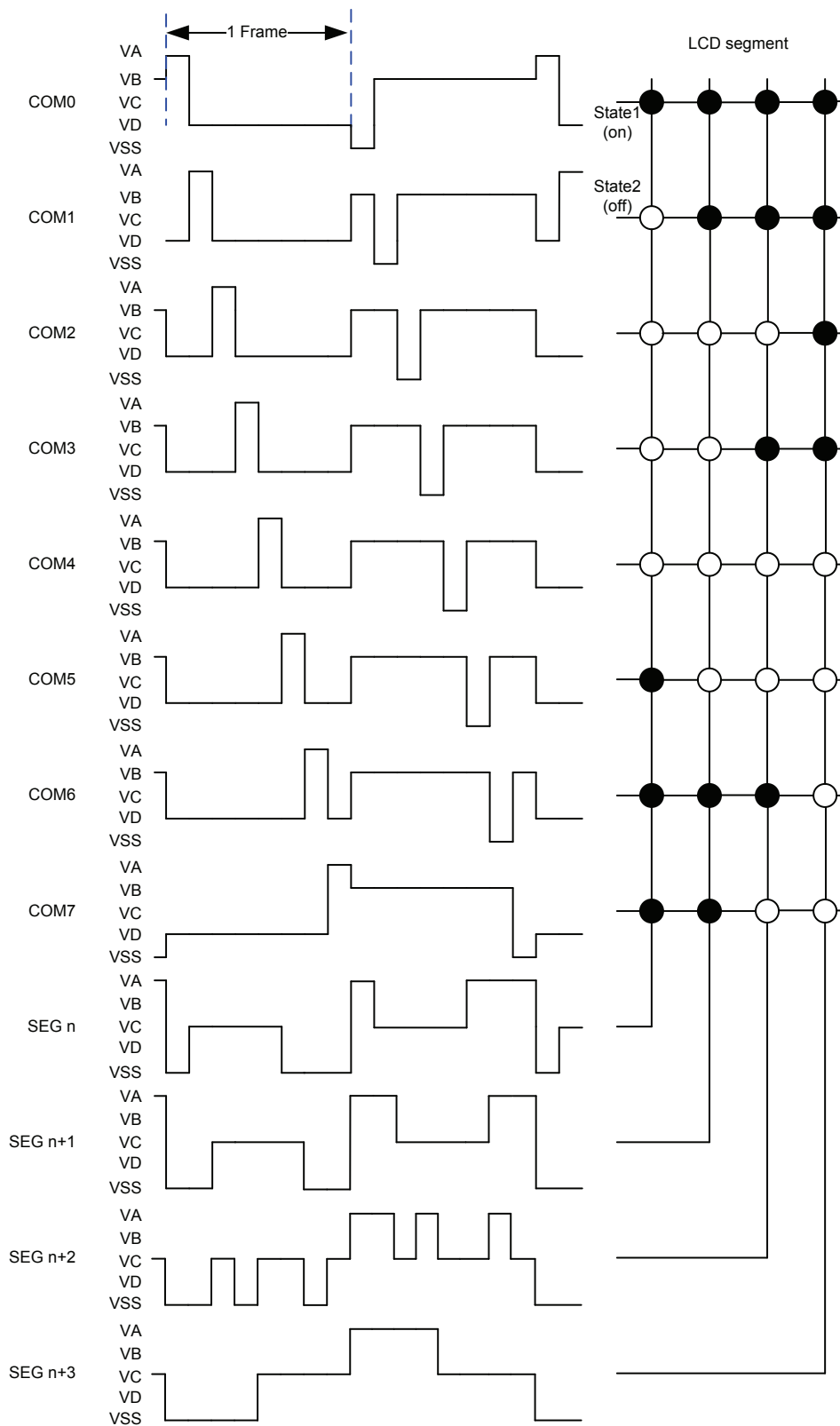

LCD Driver Output – Type B - 1/8 Duty, 1/4 Bias

LED Driver

The device contains an LED driver function offering high current output drive capability which can be used to drive external LEDs.

LED Driver Operation

The various I/O pins of device have a capability of providing LED high current drive outputs, as shown in the accompanying table.

LED Drive Pins
PD0~PD7 (high source current)
PE0~PE7 (high sink current)

LED Driver Register

IOHR0 Register

Bit	7	6	5	4	3	2	1	0
Name	IOHS31	IOHS30	IOHS21	IOHS20	IOHS11	IOHS10	IOHS01	IOHS00
R/W	R/W	R/W	R/W	R/W	R/W	R/W	R/W	R/W
POR	0	0	0	0	0	0	0	0

IOHR1 Register

Bit	7	6	5	4	3	2	1	0
Name	IOHS71	IOHS70	IOHS61	IOHS60	IOHS51	IOHS50	IOHS41	IOHS40
R/W	R/W	R/W	R/W	R/W	R/W	R/W	R/W	R/W
POR	0	0	0	0	0	0	0	0

IOHSn[1:0]: IOH capacity selection for PDn (n=0~7)

- 00: Fully source driving capacity of GPIO
- 01: 1/3 source driving capacity of GPIO
- 10: 1/4 source driving capacity of GPIO
- 11: 1/6 source driving capacity of GPIO

UART Interface

The device contains an integrated full-duplex asynchronous serial communications UART interface that enables communication with external devices that contain a serial interface. The UART function has many features and can transmit and receive data serially by transferring a frame of data with eight or nine data bits per transmission as well as being able to detect errors when the data is overwritten or incorrectly framed. The UART function possesses its own internal interrupt which can be used to indicate when a reception occurs or when a transmission terminates.

The integrated UART function contains the following features:

- Full-duplex, Universal Asynchronous Receiver and Transmitter (UART) communication
- 8 or 9 bits character length
- Even, odd or no parity options
- One or two stop bits
- Baud rate generator with 8-bit prescaler
- Parity, framing, noise and overrun error detection
- Support for interrupt on address detect (last character bit=1)
- Transmitter and receiver enabled independently
- 2-byte Deep FIFO Receive Data Buffer
- Transmit and Receive Multiple Interrupt Generation Sources:
 - ♦ Transmitter Empty
 - ♦ Transmitter Idle
 - ♦ Receiver Full
 - ♦ Receiver Overrun
 - ♦ Address Mode Detect
 - ♦ RX pin wake-up interrupt

UART External Pin Interfacing

To communicate with an external serial interface, the internal UART has two external pins known as TX and RX. The TX and RX pins are the UART transmitter and receiver pins respectively. Along with the UARTEN bit, the TXEN and RXEN bits, if set, will automatically setup these I/O or other pin-shared functional pins to their respective TX output and RX input conditions and disable any pull-high resistor option which may exist on the TX or RX pins. When the TX or RX pin function is disabled by clearing the UARTEN and TXEN or RXEN bit, the TX or RX pin can be used as a general purpose I/O or other pin-shared functional pin.

UART Data Transfer Scheme

The block diagram shows the overall data transfer structure arrangement for the UART interface. The actual data to be transmitted from the MCU is first transferred to the TXR register by the application program. The data will then be transferred to the Transmit Shift Register from where it will be shifted out, LSB first, onto the TX pin at a rate controlled by the Baud Rate Generator. Only the TXR register is mapped onto the MCU Data Memory, the Transmit Shift Register is not mapped and is therefore inaccessible to the application program.

Data to be received by the UART is accepted on the external RX pin, from where it is shifted in, LSB first, to the Receiver Shift Register at a rate controlled by the Baud Rate Generator. When the shift register is full, the data will then be transferred from the shift register to the internal RXR register, where it is buffered and can be manipulated by the application program. Only the RXR register is mapped onto the MCU Data Memory, the Receiver Shift Register is not mapped and is therefore inaccessible to the application program.

It should be noted that the actual register for data transmission and reception, although referred to in the text, and in application programs, as separate TXR and RXR registers, only exists as a single shared register in the Data Memory. This shared register known as the TXR/RXR register is used for both data transmission and data reception.

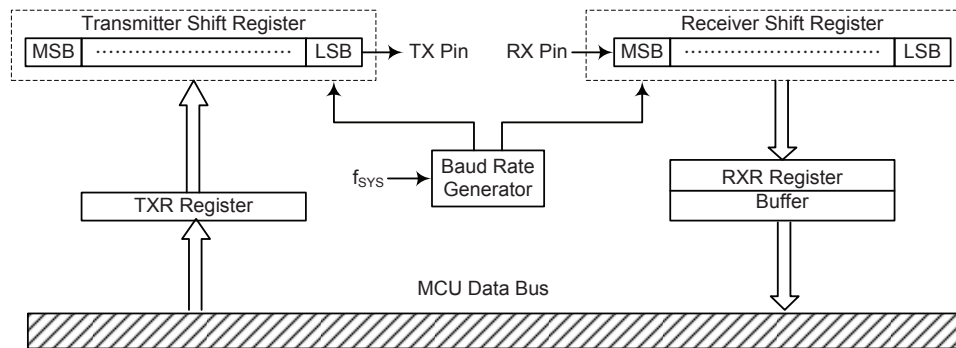

UART Data Transfer Scheme

UART Status and Control Registers

There are five control registers associated with the UART function. The USR, UCR1 and UCR2 registers control the overall function of the UART, while the BRG register controls the Baud rate. The actual data to be transmitted and received on the serial interface is managed through the TXR/RXR data register.

Register Name	Bit							
	7	6	5	4	3	2	1	0
USR	PERR	NF	FERR	OERR	RIDLE	RXIF	TIDLE	TXIF
UCR1	UARTEN	BNO	PREN	PRT	STOPS	TXBRK	RX8	TX8
UCR2	TXEN	RXEN	BRGH	ADDEN	WAKE	RIE	TIIE	TEIE
TXR/RXR	TXRX7	TXRX6	TXRX5	TXRX4	TXRX3	TXRX2	TXRX1	TXRX0
BRG	BRG7	BRG6	BRG5	BRG4	BRG3	BRG2	BRG1	BRG0

UART Register List

USR Register

The USR register is the status register for the UART, which can be read by the program to determine the present status of the UART. All flags within the USR register are read only. Further explanation on each of the flags is given below.

Bit	7	6	5	4	3	2	1	0
Name	PERR	NF	FERR	OERR	RIDLE	RXIF	TIDLE	TXIF
R/W	R	R	R	R	R	R	R	R
POR	0	0	0	0	1	0	1	1

- Bit 7 PERR:** Parity Error Flag
 0: No parity error is detected
 1: Parity error is detected
 The PERR flag is the parity error flag. When this read only flag is "0", it indicates a parity error has not been detected. When the flag is "1", it indicates that the parity of the received word is incorrect. This error flag is applicable only if Parity mode (odd or even) is selected. The flag can also be cleared by a software sequence which involves a read to the status register USR followed by an access to the RXR data register.
- Bit 6 NF:** Noise Flag
 0: No noise is detected
 1: Noise is detected
 The NF flag is the noise flag. When this read only flag is "0", it indicates no noise condition. When the flag is "1", it indicates that the UART has detected noise on the receiver input. The NF flag is set during the same cycle as the RXIF flag but will not be set in the case of an overrun. The NF flag can be cleared by a software sequence which will involve a read to the status register USR followed by an access to the RXR data register.
- Bit 5 FERR:** Framing Error Flag
 0: No framing error is detected
 1: Framing error is detected
 The FERR flag is the framing error flag. When this read only flag is "0", it indicates that there is no framing error. When the flag is "1", it indicates that a framing error has been detected for the current character. The flag can also be cleared by a software sequence which will involve a read to the status register USR followed by an access to the RXR data register.
- Bit 4 OERR:** Overrun Error Flag
 0: No overrun error is detected
 1: Overrun error is detected
 The OERR flag is the overrun error flag which indicates when the receiver buffer has overflowed. When this read only flag is "0", it indicates that there is no overrun error. When the flag is "1", it indicates that an overrun error occurs which will inhibit further transfers to the RXR receive data register. The flag is cleared by a software sequence, which is a read to the status register USR followed by an access to the RXR data register.
- Bit 3 RIDLE:** Receiver Status
 0: Data reception is in progress (data being received)
 1: No data reception is in progress (receiver is idle)
 The RIDLE flag is the receiver status flag. When this read only flag is "0", it indicates that the receiver is between the initial detection of the start bit and the completion of the stop bit. When the flag is "1", it indicates that the receiver is idle. Between the completion of the stop bit and the detection of the next start bit, the RIDLE bit is "1" indicating that the UART receiver is idle and the RX pin stays in logic high condition.

- Bit 2** **RXIF:** Receive RXR Data Register Status
 0: RXR data register is empty
 1: RXR data register has available data
 The RXIF flag is the receive data register status flag. When this read only flag is "0", it indicates that the RXR read data register is empty. When the flag is "1", it indicates that the RXR read data register contains new data. When the contents of the shift register are transferred to the RXR register, an interrupt is generated if RIE=1 in the UCR2 register. If one or more errors are detected in the received word, the appropriate receive-related flags NF, FERR, and/or PERR are set within the same clock cycle. The RXIF flag is cleared when the USR register is read with RXIF set, followed by a read from the RXR register, and if the RXR register has no data available.
- Bit 1** **TIDLE:** Transmission Idle
 0: Data transmission is in progress (data being transmitted)
 1: No data transmission is in progress (transmitter is idle)
 The TIDLE flag is known as the transmission complete flag. When this read only flag is "0", it indicates that a transmission is in progress. This flag will be set to "1" when the TXIF flag is "1" and when there is no transmit data or break character being transmitted. When TIDLE is equal to "1", the TX pin becomes idle with the pin state in logic high condition. The TIDLE flag is cleared by reading the USR register with TIDLE set and then writing to the TXR register. The flag is not generated when a data character or a break is queued and ready to be sent.
- Bit 0** **TXIF:** Transmit TXR Data Register Status
 0: Character is not transferred to the transmit shift register
 1: Character has transferred to the transmit shift register (TXR data register is empty)
 The TXIF flag is the transmit data register empty flag. When this read only flag is "0", it indicates that the character is not transferred to the transmitter shift register. When the flag is "1", it indicates that the transmitter shift register has received a character from the TXR data register. The TXIF flag is cleared by reading the UART status register (USR) with TXIF set and then writing to the TXR data register. Note that when the TXEN bit is set, the TXIF flag bit will also be set since the transmit data register is not yet full.

UCR1 Register

The UCR1 register together with the UCR2 register are the two UART control registers that are used to set the various options for the UART function, such as overall on/off control, parity control, data transfer bit length etc. Further explanation on each of the bits is given below.

Bit	7	6	5	4	3	2	1	0
Name	UARTEN	BNO	PREN	PRT	STOPS	TXBRK	RX8	TX8
R/W	R/W	R/W	R/W	R/W	R/W	R/W	R	W
POR	0	0	0	0	0	0	x	0

"x" unknown

- Bit 7** **UARTEN:** UART Function Enable Control
 0: Disable UART. TX and RX pins are in a floating state
 1: Enable UART. TX and RX pins function as UART pins
 The UARTEN bit is the UART enable bit. When this bit is equal to "0", the UART will be disabled and the RX pin as well as the TX pin will be set in a floating state. When the bit is equal to "1", the UART will be enabled and the TX and RX pins will function as defined by the TXEN and RXEN enable control bits.
 When the UART is disabled, it will empty the buffer so any character remaining in the buffer will be discarded. In addition, the value of the baud rate counter will be reset. If the UART is disabled, all error and status flags will be reset. Also the TXEN, RXEN, TXBRK, RXIF, OERR, FERR, PERR and NF bits will be cleared, while the TIDLE, TXIF and RIDLE bits will be set. Other control bits in UCR1, UCR2 and BRG registers will remain unaffected. If the UART is active and the UARTEN bit is cleared, all pending transmissions and receptions will be terminated and the module will be reset as defined above. When the UART is re-enabled, it will restart in the same configuration.

Bit 6	<p>BNO: Number of Data Transfer Bits Selection 0: 8-bit data transfer 1: 9-bit data transfer</p> <p>This bit is used to select the data length format, which can have a choice of either 8-bit or 9-bit format. When this bit is equal to "1", a 9-bit data length format will be selected. If the bit is equal to "0", then an 8-bit data length format will be selected. If 9-bit data length format is selected, then bits RX8 and TX8 will be used to store the 9th bit of the received and transmitted data respectively.</p> <p>Note: 1. If BNO=1 (9-bit data transfer), parity function is enabled, the 9th bit of data is the parity bit which will not be transferred to RX8. 2. If BNO=0 (8-bit data transfer), parity function is enabled, the 8th bit of data is the parity bit which will not be transferred to RX7.</p>
Bit 5	<p>PREN: Parity Function Enable Control 0: Parity function is disabled 1: Parity function is enabled</p> <p>This is the parity enable bit. When this bit is equal to "1", the parity function will be enabled. If the bit is equal to "0", then the parity function will be disabled.</p>
Bit 4	<p>PRT: Parity Type Selection Bit 0: Even parity for parity generator 1: Odd parity for parity generator</p> <p>This bit is the parity type selection bit. When this bit is equal to "1", odd parity type will be selected. If the bit is equal to "0", then even parity type will be selected.</p>
Bit 3	<p>STOPS: Number of Stop Bits Selection 0: One stop bit format is used 1: Two stop bits format is used</p> <p>This bit determines if one or two stop bits are to be used for the TX pin. When this bit is equal to "1", two stop bits are used. If this bit is equal to "0", then only one stop bit is used.</p>
Bit 2	<p>TXBRK: Transmit Break Character 0: No break character is transmitted 1: Break characters transmit</p> <p>The TXBRK bit is the Transmit Break Character bit. When this bit is "0", there are no break characters and the TX pin operates normally. When the bit is "1", there are transmit break characters and the transmitter will send logic zeros. When this bit is equal to "1", after the buffered data has been transmitted, the transmitter output is held low for a minimum of a 13-bit length and until the TXBRK bit is reset.</p>
Bit 1	<p>RX8: Receive Data Bit 8 for 9-bit Data Transfer Format (read only)</p> <p>This bit is only used if 9-bit data transfers are used, in which case this bit location will store the 9th bit of the received data known as RX8. The BNO bit is used to determine whether data transfers are in 8-bit or 9-bit format.</p>
Bit 0	<p>TX8: Transmit Data Bit 8 for 9-bit Data Transfer Format (write only)</p> <p>This bit is only used if 9-bit data transfers are used, in which case this bit location will store the 9th bit of the transmitted data known as TX8. The BNO bit is used to determine whether data transfers are in 8-bit or 9-bit format.</p>

UCR2 Register

The UCR2 register is the second of the two UART control registers and serves several purposes. One of its main functions is to control the basic enable/disable operation of the UART Transmitter and Receiver as well as enabling the various UART interrupt sources. The register also serves to control the baud rate speed, receiver wake-up enable and the address detect enable. Further explanation on each of the bits is given below.

Bit	7	6	5	4	3	2	1	0
Name	TXEN	RXEN	BRGH	ADDEN	WAKE	RIE	TIIE	TEIE
R/W	R/W	R/W	R/W	R/W	R/W	R/W	R/W	R/W
POR	0	0	0	0	0	0	0	0

Bit 7 TXEN: UART Transmitter Enable Control

- 0: UART transmitter is disabled
- 1: UART transmitter is enabled

The bit named TXEN is the Transmitter Enable Bit. When this bit is equal to "0", the transmitter will be disabled with any pending data transmissions being aborted. In addition the buffers will be reset. In this situation the TX pin will be set in a floating state.

If the TXEN bit is equal to "1" and the UARTEN bit is also equal to "1", the transmitter will be enabled and the TX pin will be controlled by the UART. Clearing the TXEN bit during a transmission will cause the data transmission to be aborted and will reset the transmitter. If this situation occurs, the TX pin will be set in a floating state.

Bit 6 RXEN: UART Receiver Enable Control

- 0: UART receiver is disabled
- 1: UART receiver is enabled

The bit named RXEN is the Receiver Enable Bit. When this bit is equal to "0", the receiver will be disabled with any pending data receptions being aborted. In addition the receive buffers will be reset. In this situation the RX pin will be set in a floating state. If the RXEN bit is equal to "1" and the UARTEN bit is also equal to "1", the receiver will be enabled and the RX pin will be controlled by the UART. Clearing the RXEN bit during a reception will cause the data reception to be aborted and will reset the receiver. If this situation occurs, the RX pin will be set in a floating state.

Bit 5 BRGH: Baud Rate Speed Selection

- 0: Low speed baud rate
- 1: High speed baud rate

The bit named BRGH selects the high or low speed mode of the Baud Rate Generator. This bit, together with the value placed in the baud rate register BRG, controls the Baud Rate of the UART. If this bit is equal to "1", the high speed mode is selected. If the bit is equal to "0", the low speed mode is selected.

Bit 4 ADDEN: Address Detect Function Enable Control

- 0: Address detection function is disabled
- 1: Address detection function is enabled

The bit named ADDEN is the address detect function enable control bit. When this bit is equal to "1", the address detect function is enabled. When it occurs, if the 8th bit, which corresponds to RX7 if BNO=0 or the 9th bit, which corresponds to RX8 if BNO=1, has a value of "1", then the received word will be identified as an address, rather than data. If the corresponding interrupt is enabled, an interrupt request will be generated each time the received word has the address bit set, which is the 8th or 9th bit depending on the value of BNO. If the address bit known as the 8th or 9th bit of the received word is "0" with the address detect function being enabled, an interrupt will not be generated and the received data will be discarded.

- Bit 3 WAKE:** RX Pin Falling Edge Wake-up UART Function Enable Control
 0: RX pin wake-up UART function is disabled
 1: RX pin wake-up UART function is enabled
 This bit is used to control the wake-up UART function when a falling edge on the RX pin occurs. Note that this bit is only available when the UART clock (f_{SYS}) is switched off. There will be no RX pin wake-up UART function if the UART clock (f_{SYS}) exists. If the WAKE bit is set to 1 as the UART clock (f_{SYS}) is switched off, a UART wake-up request will be initiated when a falling edge on the RX pin occurs. When this request happens and the corresponding interrupt is enabled, an RX pin wake-up UART interrupt will be generated to inform the MCU to wake up the UART function by switching on the UART clock (f_{SYS}) via the application program. Otherwise, the UART function can not resume even if there is a falling edge on the RX pin when the WAKE bit is cleared to 0.
- Bit 2 RIE:** Receiver Interrupt Enable Control
 0: Receiver related interrupt is disabled
 1: Receiver related interrupt is enabled
 This bit enables or disables the receiver interrupt. If this bit is equal to "1" and when the receiver overrun flag OERR or receive data available flag RXIF is set, the UART interrupt request flag will be set. If this bit is equal to "0", the UART interrupt request flag will not be influenced by the condition of the OERR or RXIF flags.
- Bit 1 TIE:** Transmitter IdleInterrupt Enable Control
 0: Transmitter idle interrupt is disabled
 1: Transmitter idle interrupt is enabled
 This bit enables or disables the transmitter idle interrupt. If this bit is equal to "1" and when the transmitter idle flag TIDLE is set, due to a transmitter idle condition, the UART interrupt request flag will be set. If this bit is equal to "0", the UART interrupt request flag will not be influenced by the condition of the TIDLE flag.
- Bit 0 TEIE:** Transmitter Empty Interrupt Enable Control
 0: Transmitter empty interrupt is disabled
 1: Transmitter empty interrupt is enabled
 This bit enables or disables the transmitter empty interrupt. If this bit is equal to "1" and when the transmitter empty flag TXIF is set, due to a transmitter empty condition, the UART interrupt request flag will be set. If this bit is equal to "0", the UART interrupt request flag will not be influenced by the condition of the TXIF flag.

TXR/RXR Register

The TXR/RXR register is the data register which is used to store the data to be transmitted on the TX pin or being received from the RX pin.

Bit	7	6	5	4	3	2	1	0
Name	TXRX7	TXRX6	TXRX5	TXRX4	TXRX3	TXRX2	TXRX1	TXRX0
R/W	R/W	R/W	R/W	R/W	R/W	R/W	R/W	R/W
POR	x	x	x	x	x	x	x	x

"x" unknown

- Bit 7~0 TXRX7~TXRX0:** UART Transmit/Receive Data bit 7 ~ bit 0

Baud Rate Generator

To setup the speed of the serial data communication, the UART function contains its own dedicated baud rate generator. The baud rate is controlled by its own internal free running 8-bit timer, the period of which is determined by two factors. The first of these is the value placed in the baud rate register BRG and the second is the value of the BRGH bit with the control register UCR2. The BRGH bit decides if the baud rate generator is to be used in a high speed mode or low speed mode, which in turn determines the formula that is used to calculate the baud rate. The value in the BRG register, N, which is used in the following baud rate calculation formula determines the division factor. Note that N is the decimal value placed in the BRG register and has a range of between 0 and 255.

UCR2 BRGH Bit	0	1
Baud Rate (BR)	$f_{sys} / [64 (N+1)]$	$f_{sys} / [16 (N+1)]$

By programming the BRGH bit which allows selection of the related formula and programming the required value in the BRG register, the required baud rate can be setup. Note that because the actual baud rate is determined using a discrete value, N, placed in the BRG register, there will be an error associated between the actual and requested value. The following example shows how the BRG register value N and the error value can be calculated.

BRG Register

Bit	7	6	5	4	3	2	1	0
Name	BRG7	BRG6	BRG5	BRG4	BRG3	BRG2	BRG1	BRG0
R/W	R/W	R/W	R/W	R/W	R/W	R/W	R/W	R/W
POR	x	x	x	x	x	x	x	x

"x" unknown

Bit 7~0 **BRG7~BRG0**: Baud Rate Values

By programming the BRGH bit in UCR2 Register which allows selection of the related formula described above and programming the required value in the BRG register, the required baud rate can be setup.

Note: 1. Baud rate = $f_{sys} / [64 (N+1)]$ if BRGH=0.

2. Baud rate = $f_{sys} / [16 (N+1)]$ if BRGH=1.

Calculating the Baud Rate and error values

For a clock frequency of 4MHz, and with BRGH set to "0" determine the BRG register value N, the actual baud rate and the error value for a desired baud rate of 4800.

From the above table the desired baud rate $BR = f_{sys} / [64 (N+1)]$

Re-arranging this equation gives $N = [f_{sys} / (BR \times 64)] - 1$

Giving a value for $N = [4000000 / (4800 \times 64)] - 1 = 12.0208$

To obtain the closest value, a decimal value of 12 should be placed into the BRG register. This gives an actual or calculated baud rate value of $BR = 4000000 / [64 \times (12 + 1)] = 4808$

Therefore the error is equal to $(4808 - 4800) / 4800 = 0.16\%$

The following table shows actual values of baud rate and error values for the two values of BRGH.

Baud Rate K/BPS	f _{sys} =8MHz					
	Baud Rates for BRGH=0			Baud Rates for BRGH=1		
	BRG	Kbaud	Error (%)	BRG	Kbaud	Error (%)
0.3	—	—	—	—	—	—
1.2	103	1.202	0.16	—	—	—
2.4	51	2.404	0.16	207	2.404	0.16
4.8	25	4.808	0.16	103	4.808	0.16
9.6	12	9.615	0.16	51	9.615	0.16
19.2	6	17.8857	-6.99	25	19.231	0.16
38.4	2	41.667	8.51	12	38.462	0.16
57.6	1	62.500	8.51	8	55.556	-3.55
115.2	0	125	8.51	3	125	8.51
250	—	—	—	1	250	0

Baud Rates and Error Values

UART Setup and Control

For data transfer, the UART function utilizes a non-return-to-zero, more commonly known as NRZ format. This is composed of one start bit, eight or nine data bits, and one or two stop bits. Parity is supported by the UART hardware, and can be setup to be even, odd or no parity. For the most common data format, 8 data bits along with no parity and one stop bit, denoted as 8, N, 1, is used as the default setting, which is the setting at power-on. The number of data bits and stop bits, along with the parity, are setup by programming the corresponding BNO, PRT, PREN, and STOPS bits in the UCR1 register. The baud rate used to transmit and receive data is setup using the internal 8-bit baud rate generator, while the data is transmitted and received LSB first. Although the UART transmitter and receiver are functionally independent, they both use the same data format and baud rate. In all cases stop bits will be used for data transmission.

Enabling/Disabling the UART Interface

The basic on/off function of the internal UART function is controlled using the UARTEN bit in the UCR1 register. If the UARTEN, TXEN and RXEN bits are set, then these two UART pins will act as normal TX output pin and RX input pin respectively. If no data is being transmitted on the TX pin, then it will default to a logic high value.

Clearing the UARTEN bit will disable the TX and RX pins and allow these two pins to be used as normal I/O or other pin-shared functional pins. When the UART function is disabled the buffer will be reset to an empty condition, at the same time discarding any remaining residual data. Disabling the UART will also reset the error and status flags with bits TXEN, RXEN, TXBRK, RXIF, OERR, FERR, PERR and NF being cleared while bits TIDLE, TXIF and RIDLE will be set. The remaining control bits in the UCR1, UCR2 and BRG registers will remain unaffected. If the UARTEN bit in the UCR1 register is cleared while the UART is active, then all pending transmissions and receptions will be immediately suspended and the UART will be reset to a condition as defined above. If the UART is then subsequently re-enabled, it will restart again in the same configuration.

Data, Parity and Stop Bit Selection

The format of the data to be transferred is composed of various factors such as data bit length, parity on/off, parity type, address bits and the number of stop bits. These factors are determined by the setup of various bits within the UCR1 register. The BNO bit controls the number of data bits which can be set to either 8 or 9, the PRT bit controls the choice of odd or even parity, the PREN bit controls the parity on/off function and the STOPS bit decides whether one or two stop bits are to be used. The following table shows various formats for data transmission. The address bit, which is the MSB of the data byte, identifies the frame as an address character or data if the address detect function is enabled. The number of stop bits, which can be either one or two, is independent of the data length and are only to be used for Transmitter. There is only one stop bit for Receiver.

Start Bit	Data Bits	Address Bits	Parity Bits	Stop Bit
Example of 8-bit Data Formats				
1	8	0	0	1
1	7	0	1	1
1	7	1	0	1
Example of 9-bit Data Formats				
1	9	0	0	1
1	8	0	1	1
1	8	1	0	1

Transmitter Receiver Data Format

The following diagram shows the transmit and receive waveforms for both 8-bit and 9-bit data formats.

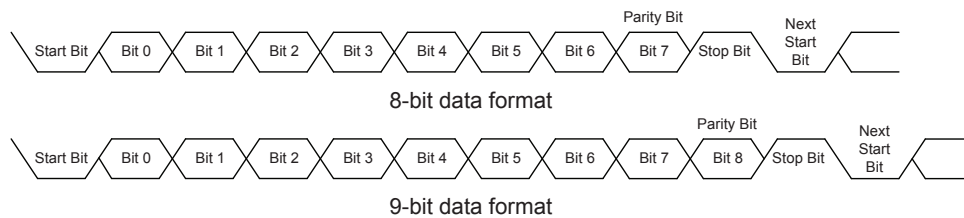

UART Transmitter

Data word lengths of either 8 or 9 bits can be selected by programming the BNO bit in the UCR1 register. When BNO bit is set, the word length will be set to 9 bits. In this case the 9th bit, which is the MSB, needs to be stored in the TX8 bit in the UCR1 register. At the transmitter core lies the Transmitter Shift Register, more commonly known as the TSR, whose data is obtained from the transmit data register, which is known as the TXR register. The data to be transmitted is loaded into this TXR register by the application program. The TSR register is not written to with new data until the stop bit from the previous transmission has been sent out. As soon as this stop bit has been transmitted, the TSR can then be loaded with new data from the TXR register, if it is available. It should be noted that the TSR register, unlike many other registers, is not directly mapped into the Data Memory area and as such is not available to the application program for direct read/write operations. An actual transmission of data will normally be enabled when the TXEN bit is set, but the data will not be transmitted until the TXR register has been loaded with data and the baud rate generator has defined a shift clock source. However, the transmission can also be initiated by first loading data into the TXR register, after which the TXEN bit can be set. When a transmission of data begins, the TSR is normally empty, in which case a transfer to the TXR register will result in an immediate transfer to the TSR. If during a transmission the TXEN bit is cleared, the transmission will immediately cease and the transmitter will be reset. The TX output pin will then return to the I/O or other pin-shared function.

Transmitting Data

When the UART is transmitting data, the data is shifted on the TX pin from the shift register, with the least significant bit first. In the transmit mode, the TXR register forms a buffer between the internal bus and the transmitter shift register. It should be noted that if 9-bit data format has been selected, then the MSB will be taken from the TX8 bit in the UCR1 register. The steps to initiate a data transfer can be summarized as follows:

- Make the correct selection of the BNO, PRT, PREN and STOPS bits to define the required word length, parity type and number of stop bits.
- Setup the BRG register to select the desired baud rate.
- Set the TXEN bit to ensure that the UART transmitter is enabled and the TX pin is used as a UART transmitter pin.
- Access the USR register and write the data that is to be transmitted into the TXR register. Note that this step will clear the TXIF bit.

This sequence of events can now be repeated to send additional data. It should be noted that when TXIF is "0", data will be inhibited from being written to the TXR register. Clearing the TXIF flag is always achieved using the following software sequence:

- A USR register access
- A TXR register write execution

The read-only TXIF flag is set by the UART hardware and if set indicates that the TXR register is empty and that other data can now be written into the TXR register without overwriting the previous data. If the TEIE bit is set then the TXIF flag will generate an interrupt. During a data transmission, a write instruction to the TXR register will place the data into the TXR register, which will be copied to the shift register at the end of the present transmission. When there is no data transmission in progress, a write instruction to the TXR register will place the data directly into the shift register, resulting in the commencement of data transmission, and the TXIF bit being immediately set. When a frame transmission is complete, which happens after stop bits are sent or after the break frame, the TIDLE bit will be set. To clear the TIDLE bit the following software sequence is used:

- A USR register access
- A TXR register write execution

Note that both the TXIF and TIDLE bits are cleared by the same software sequence.

Transmit Break

If the TXBRK bit is set then break characters will be sent on the next transmission. Break character transmission consists of a start bit, followed by $13 \times N$ '0' bits and stop bits, where $N=1, 2$, etc. If a break character is to be transmitted then the TXBRK bit must be first set by the application program and then cleared to generate the stop bits. Transmitting a break character will not generate a transmit interrupt. Note that a break condition length is at least 13 bits long. If the TXBRK bit is continually kept at a logic high level then the transmitter circuitry will transmit continuous break characters. After the application program has cleared the TXBRK bit, the transmitter will finish transmitting the last break character and subsequently send out one or two stop bits. The automatic logic highs at the end of the last break character will ensure that the start bit of the next frame is recognized.

UART Receiver

The UART is capable of receiving word lengths of either 8 or 9 bits can be selected by programming the BNO bit in the UCR register. If the BNO bit is set, the word length will be set to 9 bits with the MSB being stored in the RX8 bit of the UCR1 register. At the receiver core lies the Receive Serial Shift Register, commonly known as the RSR. The data which is received on the RX external input pin is sent to the data recovery block. The data recovery block operating speed is 16 times that of the baud rate, while the main receive serial shifter operates at the baud rate. After the RX pin is sampled for the stop bit, the received data in RSR is transferred to the receive data register, if the register is empty. The data which is received on the external RX input pin is sampled three times by a majority detect circuit to determine the logic level that has been placed onto the RX pin. It should be noted that the RSR register, unlike many other registers, is not directly mapped into the Data Memory area and as such is not available to the application program for direct read/write operations.

Receiving Data

When the UART receiver is receiving data, the data is serially shifted in on the external RX input pin to the shift register, with the least significant bit LSB first. The RXR register is a two byte deep FIFO data buffer, where two bytes can be held in the FIFO while a third byte can continue to be received. Note that the application program must ensure that the data is read from RXR before the third byte has been completely shifted in, otherwise this third byte will be discarded and an overrun error OERR will be subsequently indicated. The steps to initiate a data transfer can be summarized as follows:

- Make the correct selection of BNO, PRT and PREN bits to define the word length and parity type.
- Setup the BRG register to select the desired baud rate.
- Set the RXEN bit to ensure that the UART receiver is enabled and the RX pin is used as a UART receiver pin.

At this point the receiver will be enabled which will begin to look for a start bit.

When a character is received, the following sequence of events will occur:

- The RXIF bit in the USR register will be set when the RXR register has data available. There will be at most one more characters available before an overrun error occurs.
- When the contents of the shift register have been transferred to the RXR register and if the RIE bit is set, then an interrupt will be generated.
- If during reception, a frame error, noise error, parity error, or an overrun error has been detected, then the error flags can be set.

The RXIF bit can be cleared using the following software sequence:

- A USR register access
- An RXR register read execution

Receive Break

Any break character received by the UART will be managed as a framing error. The receiver will count and expect a certain number of bit times as specified by the values programmed into the BNO and plusing one STOP bit. If the break is much longer than 13 bit times, the reception will be considered as complete after the number of bit times specified by BNO and plusing one STOP bit. The RXIF bit is set, FERR is set, zeros are loaded into the receive data register, interrupts are generated if appropriate and the RIDLE bit is set. A break is regarded as a character that contains only zeros with the FERR flag set. If a long break signal has been detected, the receiver will regard it as a data frame including a start bit, data bits and the invalid stop bit and the FERR flag will be set. The receiver must wait for a valid stop bit before looking for the next start bit. The receiver will not make the assumption that the break condition on the line is the next start bit. The break character will be loaded into the buffer and no further data will be received until stop bits are received. It should be noted that the RIDLE read only flag will go high when the stop bits have not yet been received. The reception of a break character on the UART registers will result in the following:

- The framing error flag, FERR, will be set.
- The receive data register, RXR, will be cleared.
- The OERR, NF, PERR, RIDLE or RXIF flags will possibly be set.

Idle Status

When the receiver is reading data, which means it will be in between the detection of a start bit and the reading of a stop bit, the receiver status flag in the USR register, otherwise known as the RIDLE flag, will have a zero value. In between the reception of a stop bit and the detection of the next start bit, the RIDLE flag will have a high value, which indicates the receiver is in an idle condition.

Receiver Interrupt

The read only receive interrupt flag RXIF in the USR register is set by an edge generated by the receiver. An interrupt is generated if RIE bit is "1", when a word is transferred from the Receive Shift Register, RSR, to the Receive Data Register, RXR. An overrun error can also generate an interrupt if RIE is "1".

Managing Receiver Errors

Several types of reception errors can occur within the UART module, the following section describes the various types and how they are managed by the UART.

Overrun Error – OERR Flag

The RXR register is composed of a two byte deep FIFO data buffer, where two bytes can be held in the FIFO register, while a third byte can continue to be received. Before this third byte has been entirely shifted in, the data should be read from the RXR register. If this is not done, the overrun error flag OERR will be consequently indicated.

In the event of an overrun error occurring, the following will happen:

- The OERR flag in the USR register will be set.
- The RXR contents will not be lost.
- The shift register will be overwritten.
- An interrupt will be generated if the RIE bit is set.

The OERR flag can be cleared by an access to the USR register followed by a read to the RXR register.

Noise Error – NF Flag

Over-sampling is used for data recovery to identify valid incoming data and noise. If noise is detected within a frame the following will occur:

- The read only noise flag, NF, in the USR register will be set on the rising edge of the RXIF bit.
- Data will be transferred from the Shift register to the RXR register.
- No interrupt will be generated. However this bit rises at the same time as the RXIF bit which itself generates an interrupt.

Note that the NF flag is reset by a USR register read operation followed by an RXR register read operation.

Framing Error – FERR Flag

The read only framing error flag, FERR, in the USR register, is set if a zero is detected instead of stop bits. If two stop bits are selected, only the first stop bit is detected, it must be high. If the first stop bit is low, the FERR flag will be set. The FERR flag and the received data will be recorded in the USR and RXR registers respectively, and the flag is cleared in any reset.

Parity Error – PERR Flag

The read only parity error flag, PERR, in the USR register, is set if the parity of the received word is incorrect. This error flag is only applicable if the parity is enabled, PREN bit is "1", and if the parity type, odd or even is selected. The read only PERR flag and the received data will be recorded in the USR and RXR registers respectively. It is cleared on any reset, it should be noted that the flags, FERR and PERR, in the USR register should first be read by the application program before reading the data word.

UART Module Interrupt Structure

Several individual UART conditions can generate a UART interrupt. When these conditions exist, a low pulse will be generated to get the attention of the microcontroller. These conditions are a transmitter data register empty, transmitter idle, receiver data available, receiver overrun, address detect and an RX pin wake-up. When any of these conditions are created, if its corresponding interrupt control is enabled and the stack is not full, the program will jump to its corresponding interrupt vector where it can be serviced before returning to the main program. Four of these conditions have the corresponding USR register flags which will generate a UART interrupt if its associated interrupt enable control bit in the UCR2 register is set. The two transmitter interrupt conditions have their own corresponding enable control bits, while the two receiver interrupt conditions have a shared enable control bit. These enable bits can be used to mask out individual UART interrupt sources.

The address detect condition, which is also a UART interrupt source, does not have an associated flag, but will generate a UART interrupt when an address detect condition occurs if its function is enabled by setting the ADDEN bit in the UCR2 register. An RX pin wake-up, which is also a UART interrupt source, does not have an associated flag, but will generate a UART interrupt if the UART clock (f_{SYS}) is switched off and the WAKE and RIE bits in the UCR2 register are set when a falling edge on the RX pin occurs.

Note that the USR register flags are read only and cannot be cleared or set by the application program, neither will they be cleared when the program jumps to the corresponding interrupt servicing routine, as is the case for some of the other interrupts. The flags will be cleared automatically when certain actions are taken by the UART, the details of which are given in the UART register section. The overall UART interrupt can be disabled or enabled by the related interrupt enable control bits in the interrupt control registers of the microcontroller to decide whether the interrupt requested by the UART module is masked out or allowed.

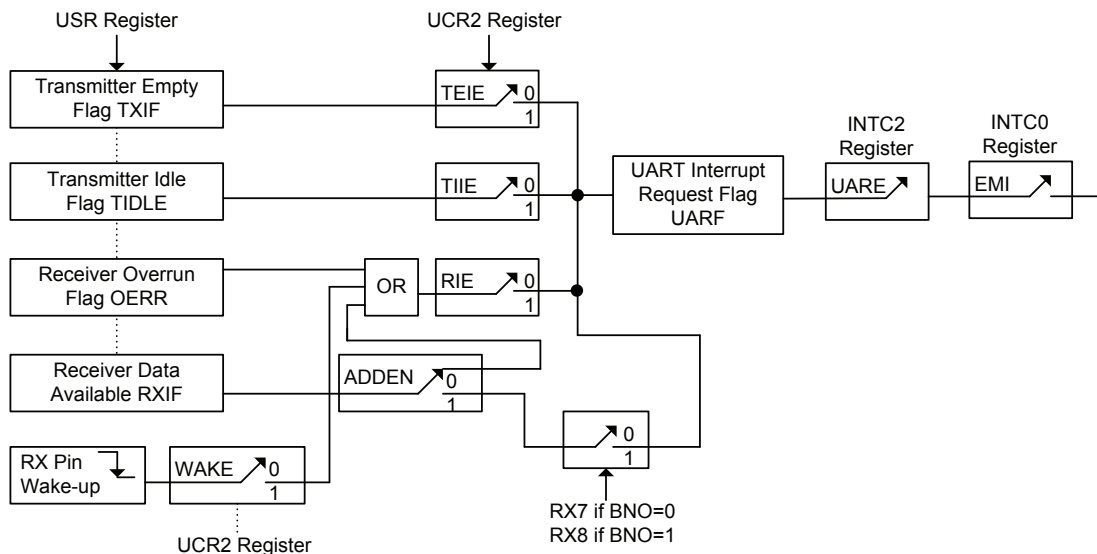

UART Interrupt Scheme

Address Detect Mode

Setting the Address Detect Mode bit, ADDEN, in the UCR2 register, enables this special mode. If this bit is enabled then an additional qualifier will be placed on the generation of a Receiver Data Available interrupt, which is requested by the RXIF flag. If the ADDEN bit is "1", then when data is available, an interrupt will only be generated, if the highest received bit has a high value. Note that the related interrupt enable control bit and the EMI bit must also be enabled for correct interrupt generation. This highest address bit is the 9th bit if BNO bit is "1" or the 8th bit if BNO bit is "0". If this bit is high, then the received word will be defined as an address rather than data. A Data Available interrupt will be generated every time the last bit of the received word is set. If the ADDEN bit is "0", then a Receiver Data Available interrupt will be generated each time the RXIF flag is set, irrespective of the data last bit status. The address detect mode and parity enable are mutually exclusive functions. Therefore if the address detect mode is enabled, then to ensure correct operation, the parity function should be disabled by resetting the parity enable bit PREN to zero.

ADDEN	Bit 9 if BNO=1, Bit 8 if BNO=0	UART Interrupt Generated
0	0	√
	1	√
1	0	×
	1	√

ADDEN Bit Function

UART Power Down and Wake-up

When the UART clock (f_{SYS}) is switched off, the UART will cease to function, all clock sources to the module are shutdown. If the UART clock (f_{SYS}) is off while a transmission is still in progress, then the transmission will be paused until the UART clock (f_{SYS}) source derived from the microcontroller is activated. In a similar way, if the device executes the "HALT" instruction and switches off the system clock while receiving data, then the reception of data will likewise be paused. When the device enters the IDLE or SLEEP Mode, note that the USR, UCR1, UCR2, transmit and receive registers, as well as the BRG register will not be affected. It is recommended to make sure first that the UART data transmission or reception has been finished before the microcontroller enters the IDLE or SLEEP mode.

The UART function contains a receiver RX pin wake-up function, which is enabled or disabled by the WAKE bit in the UCR2 register. If this bit, along with the UART enable bit, UARTEN, the receiver enable bit, RXEN and the receiver interrupt bit, RIE, are all set when the UART clock (f_{SYS}) is off, then a falling edge on the RX pin will trigger an RX pin wake-up UART interrupt. Note that as it takes certain system clock cycles after a wake-up, before normal microcontroller operation resumes, any data received during this time on the RX pin will be ignored.

For a UART wake-up interrupt to occur, in addition to the bits for the wake-up being set, the global interrupt enable bit, EMI, and the UART interrupt enable bit, UARE, must also be set. If these two bits are not set then only a wake up event will occur and no interrupt will be generated. Note also that as it takes certain system clock cycles after a wake-up before normal microcontroller resumes, the UART interrupt will not be generated until after this time has elapsed.

Interrupts

Interrupts are an important part of any microcontroller system. When an external event or an internal function such as a Timer Module or an A/D converter requires microcontroller attention, their corresponding interrupt will enforce a temporary suspension of the main program allowing the microcontroller to direct attention to their respective needs. The device contains several external interrupt and internal interrupt functions. The external interrupts are generated by the action of the external INT0~INT3 pins, while the internal interrupts are generated by various internal functions such as the Timer Modules, Time Bases, Serial Interface Module, Low Voltage Detector, EEPROM, UART and the A/D converter.

Interrupt Registers

Overall interrupt control, which basically means the setting of request flags when certain microcontroller conditions occur and the setting of interrupt enable bits by the application program, is controlled by a series of registers, located in the Special Purpose Data Memory. The registers fall into three categories. The first is the INTC0~INTC3 registers which setup the primary interrupts, the second is the MF10~MF14 registers which setup the Multi-function interrupts. Finally there is an INTEG register to setup the external interrupts trigger edge type.

Each register contains a number of enable bits to enable or disable individual registers as well as interrupt flags to indicate the presence of an interrupt request. The naming convention of these follows a specific pattern. First is listed an abbreviated interrupt type, then the (optional) number of that interrupt followed by either an "E" for enable/disable bit or "F" for request flag.

Function	Enable Bit	Request Flag	Notes
Global	EMI	—	—
INTn Pin	INTnE	INTnF	n=0~3
A/D Converter	ADE	ADF	—
Multi-function	MFnE	MFnF	n=0~4
Time Base	TBnE	TBnF	n=0~1
LVD	LVE	LVF	—
EEPROM	DEE	DEF	—
UART	UARE	UARF	—
SIM	SIME	SIMF	—
TM	TnPE	TnPF	n=0~3
	TnAE	TnAF	

Interrupt Register Bit Naming Conventions

Register Name	Bit							
	7	6	5	4	3	2	1	0
INTEG	INT3S1	INT3S0	INT2S1	INT2S0	INT1S1	INT1S0	INT0S1	INT0S0
INTC0	—	MF0F	INT1F	INT0F	MF0E	INT1E	INT0E	EMI
INTC1	ADF	MF3F	MF2F	MF1F	ADE	MF3E	MF2E	MF1E
INTC2	MF4F	INT3F	INT2F	UARF	MF4E	INT3E	INT2E	UARE
INTC3	—	—	—	SIMF	—	—	—	SIME
MF10	—	—	T0AF	T0PF	—	—	T0AE	T0PE
MF11	—	—	T1AF	T1PF	—	—	T1AE	T1PE
MF12	—	—	T2AF	T2PF	—	—	T2AE	T2PE
MF13	—	—	T3AF	T3PF	—	—	T3AE	T3PE
MF14	TB1F	TB0F	DEF	LVF	TB1E	TB0E	DEE	LVE

Interrupt Register List

INTEG Register

Bit	7	6	5	4	3	2	1	0
Name	INT3S1	INT3S0	INT2S1	INT2S0	INT1S1	INT1S0	INT0S1	INT0S0
R/W	R/W	R/W	R/W	R/W	R/W	R/W	R/W	R/W
POR	0	0	0	0	0	0	0	0

- Bit 7~6 **INT3S1~INT3S0**: Interrupt Edge Control for INT3 Pin
 00: Disable
 01: Rising edge
 10: Falling edge
 11: Rising and falling edges
- Bit 5~4 **INT2S1~INT2S0**: Interrupt Edge Control for INT2 Pin
 00: Disable
 01: Rising edge
 10: Falling edge
 11: Rising and falling edges
- Bit 3~2 **INT1S1~INT1S0**: Interrupt EdgeControl for INT1 Pin
 00: Disable
 01: Rising edge
 10: Falling edge
 11: Rising and falling edges
- Bit 1~0 **INT0S1~INT0S0**: Interrupt Edge Control for INT0 Pin
 00: Disable
 01: Rising edge
 10: Falling edge
 11: Rising and falling edges

INTC0 Register

Bit	7	6	5	4	3	2	1	0
Name	—	MF0F	INT1F	INT0F	MF0E	INT1E	INT0E	EMI
R/W	—	R/W	R/W	R/W	R/W	R/W	R/W	R/W
POR	—	0	0	0	0	0	0	0

- Bit 7 Unimplemented, read as "0"
- Bit 6 **MF0F**: Multi-function Interrupt 0 Request Flag
 0: No request
 1: Interrupt request
- Bit 5 **INT1F**: External Interrupt 1 Request Flag
 0: No request
 1: Interrupt request
- Bit 4 **INT0F**: External Interrupt 0 Request Flag
 0: No request
 1: Interrupt request
- Bit 3 **MF0E**: Multi-function Interrupt 0 Control
 0: Disable
 1: Enable
- Bit 2 **INT1E**: External Interrupt 1 Control
 0: Disable
 1: Enable
- Bit 1 **INT0E**: External Interrupt 0 Control
 0: Disable
 1: Enable
- Bit 0 **EMI**: Global Interrupt Control
 0: Disable
 1: Enable

INTC1 Register

Bit	7	6	5	4	3	2	1	0
Name	ADF	MF3F	MF2F	MF1F	ADE	MF3E	MF2E	MF1E
R/W	R/W	R/W	R/W	R/W	R/W	R/W	R/W	R/W
POR	0	0	0	0	0	0	0	0

- Bit 7 **ADF**: A/D Converter Interrupt Request Flag
 0: No request
 1: Interrupt request
- Bit 6 **MF3F**: Multi-function Interrupt 3 Request Flag
 0: No request
 1: Interrupt request
- Bit 5 **MF2F**: Multi-function Interrupt 2 Request Flag
 0: No request
 1: Interrupt request
- Bit 4 **MF1F**: Multi-function Interrupt 1 Request Flag
 0: No request
 1: Interrupt request
- Bit 3 **ADE**: A/D Converter Interrupt Control
 0: Disable
 1: Enable
- Bit 2 **MF3E**: Multi-function Interrupt 3 Control
 0: Disable
 1: Enable
- Bit 1 **MF2E**: Multi-function Interrupt 2 Control
 0: Disable
 1: Enable
- Bit 0 **MF1E**: Multi-function Interrupt 1 Control
 0: Disable
 1: Enable

INTC2 Register

Bit	7	6	5	4	3	2	1	0
Name	MF4F	INT3F	INT2F	UARF	MF4E	INT3E	INT2E	UARE
R/W	R/W	R/W	R/W	R/W	R/W	R/W	R/W	R/W
POR	0	0	0	0	0	0	0	0

- Bit 7 **MF4F**: Multi-function Interrupt 4 Request Flag
 0: No request
 1: Interrupt request
- Bit 6 **INT3F**: External Interrupt 3 Request Flag
 0: No request
 1: Interrupt request
- Bit 5 **INT2F**: External Interrupt 2 Request Flag
 0: No request
 1: Interrupt request
- Bit 4 **UARF**: UART Interrupt Request Flag
 0: No request
 1: Interrupt request
- Bit 3 **MF4E**: Multi-function Interrupt 4 Control
 0: Disable
 1: Enable

- Bit 2 **INT3E**: External Interrupt 3 Control
 0: Disable
 1: Enable
- Bit 1 **INT2E**: External Interrupt 2 Control
 0: Disable
 1: Enable
- Bit 0 **UARE**: UART Interrupt Control
 0: Disable
 1: Enable

INTC3 Register

Bit	7	6	5	4	3	2	1	0
Name	—	—	—	SIMF	—	—	—	SIME
R/W	—	—	—	R/W	—	—	—	R/W
POR	—	—	—	0	—	—	—	0

- Bit 7~5 Unimplemented, read as "0"
- Bit 4 **SIMF**: Serial Interface Module Interrupt Request Flag
 0: No request
 1: Interrupt request
- Bit 3~1 Unimplemented, read as "0"
- Bit 0 **SIME**: Serial Interface Module Control
 0: Disable
 1: Enable

MFIO Register

Bit	7	6	5	4	3	2	1	0
Name	—	—	T0AF	T0PF	—	—	T0AE	T0PE
R/W	—	—	R/W	R/W	—	—	R/W	R/W
POR	—	—	0	0	—	—	0	0

- Bit 7~6 Unimplemented, read as "0"
- Bit 5 **T0AF**: TM0 CCRA Comparator Interrupt Request Flag
 0: No request
 1: Interrupt request
- Bit 4 **T0PF**: TM0 CCRP Comparator Interrupt Request Flag
 0: No request
 1: Interrupt request
- Bit 3~2 Unimplemented, read as "0"
- Bit 1 **T0AE**: TM0 CCRA Comparator Interrupt Control
 0: Disable
 1: Enable
- Bit 0 **T0PE**: TM0 CCRP Comparator Interrupt Control
 0: Disable
 1: Enable

MF11 Register

Bit	7	6	5	4	3	2	1	0
Name	—	—	T1AF	T1PF	—	—	T1AE	T1PE
R/W	—	—	R/W	R/W	—	—	R/W	R/W
POR	—	—	0	0	—	—	0	0

- Bit 7~6 Unimplemented, read as "0"
- Bit 5 **T1AF**: TM1 CCRA Comparator Interrupt Request Flag
 0: No request
 1: Interrupt request
- Bit 4 **T1PF**: TM1 CCRP Comparator Interrupt Request Flag
 0: No request
 1: Interrupt request
- Bit 3~2 Unimplemented, read as "0"
- Bit 1 **T1AE**: TM1 CCRA Comparator Interrupt Control
 0: Disable
 1: Enable
- Bit 0 **T1PE**: TM1 CCRP Comparator Interrupt Control
 0: Disable
 1: Enable

MF12 Register

Bit	7	6	5	4	3	2	1	0
Name	—	—	T2AF	T2PF	—	—	T2AE	T2PE
R/W	—	—	R/W	R/W	—	—	R/W	R/W
POR	—	—	0	0	—	—	0	0

- Bit 7~6 Unimplemented, read as "0"
- Bit 5 **T2AF**: TM2 CCRA Comparator Interrupt Request Flag
 0: No request
 1: Interrupt request
- Bit 4 **T2PF**: TM2 CCRP Comparator Interrupt Request Flag
 0: No request
 1: Interrupt request
- Bit 3~2 Unimplemented, read as "0"
- Bit 1 **T2AE**: TM2 CCRA Comparator Interrupt Control
 0: Disable
 1: Enable
- Bit 0 **T2PE**: TM2 CCRP Comparator Interrupt Control
 0: Disable
 1: Enable

MFI3 Register

Bit	7	6	5	4	3	2	1	0
Name	—	—	T3AF	T3PF	—	—	T3AE	T3PE
R/W	—	—	R/W	R/W	—	—	R/W	R/W
POR	—	—	0	0	—	—	0	0

- Bit 7~6 Unimplemented, read as "0"
- Bit 5 **T3AF**: TM3 CCRA Comparator Interrupt Request Flag
0: No request
1: Interrupt request
- Bit 4 **T3PF**: TM3 CCRP Comparator Interrupt Request Flag
0: No request
1: Interrupt request
- Bit 3~2 Unimplemented, read as "0"
- Bit 1 **T3AE**: TM3 CCRA Comparator Interrupt Control
0: Disable
1: Enable
- Bit 0 **T3PE**: TM3 CCRP Comparator Interrupt Control
0: Disable
1: Enable

MFI4 Register

Bit	7	6	5	4	3	2	1	0
Name	TB1F	TB0F	DEF	LVF	TB1E	TB0E	DEE	LVE
R/W	R/W	R/W	R/W	R/W	R/W	R/W	R/W	R/W
POR	0	0	0	0	0	0	0	0

- Bit 7 **TB1F**: Timer Base 1 Interrupt Request Flag
0: No request
1: Interrupt request
- Bit 6 **TB0F**: Timer Base 0 Interrupt Request Flag
0: No request
1: Interrupt request
- Bit 5 **DEF**: Data EEPROM Interrupt Request Flag
0: No request
1: Interrupt request
- Bit 4 **LVF**: LVD Interrupt Request Flag
0: No request
1: Interrupt request
- Bit 3 **TB1E**: Timer Base 1 Interrupt Control
0: Disable
1: Enable
- Bit 2 **TB0E**: Timer Base 0 Interrupt Control
0: Disable
1: Enable
- Bit 1 **DEE**: Data EEPROM Interrupt Control
0: Disable
1: Enable
- Bit 0 **LVE**: LVD Interrupt Control
0: Disable
1: Enable

Interrupt Operation

When the conditions for an interrupt event occur, such as a TM Comparator P, Comparator A match or A/D conversion completion etc., the relevant interrupt request flag will be set. Whether the request flag actually generates a program jump to the relevant interrupt vector is determined by the condition of the interrupt enable bit. If the enable bit is set high then the program will jump to its relevant vector; if the enable bit is zero then although the interrupt request flag is set an actual interrupt will not be generated and the program will not jump to the relevant interrupt vector. The global interrupt enable bit, if cleared to zero, will disable all interrupts.

When an interrupt is generated, the Program Counter, which stores the address of the next instruction to be executed, will be transferred onto the stack. The Program Counter will then be loaded with a new address which will be the value of the corresponding interrupt vector. The microcontroller will then fetch its next instruction from this interrupt vector. The instruction at this vector will usually be a "JMP" which will jump to another section of program which is known as the interrupt service routine. Here is located the code to control the appropriate interrupt. The interrupt service routine must be terminated with a "RETI", which retrieves the original Program Counter address from the stack and allows the microcontroller to continue with normal execution at the point where the interrupt occurred.

The various interrupt enable bits, together with their associated request flags, are shown in the accompanying diagrams with their order of priority. Some interrupt sources have their own individual vector while others share the same multi-function interrupt vector. Once an interrupt subroutine is serviced, all the other interrupts will be blocked, as the global interrupt enable bit, EMI bit will be cleared automatically. This will prevent any further interrupt nesting from occurring. However, if other interrupt requests occur during this interval, although the interrupt will not be immediately serviced, the request flag will still be recorded.

If an interrupt requires immediate servicing while the program is already in another interrupt service routine, the EMI bit should be set after entering the routine, to allow interrupt nesting. If the stack is full, the interrupt request will not be acknowledged, even if the related interrupt is enabled, until the Stack Pointer is decremented. If immediate service is desired, the stack must be prevented from becoming full. In case of simultaneous requests, the accompanying diagram shows the priority that is applied. All of the interrupt request flags when set will wake-up the device if it is in SLEEP or IDLE Mode, however to prevent a wake-up from occurring the corresponding flag should be set before the device is in SLEEP or IDLE Mode.

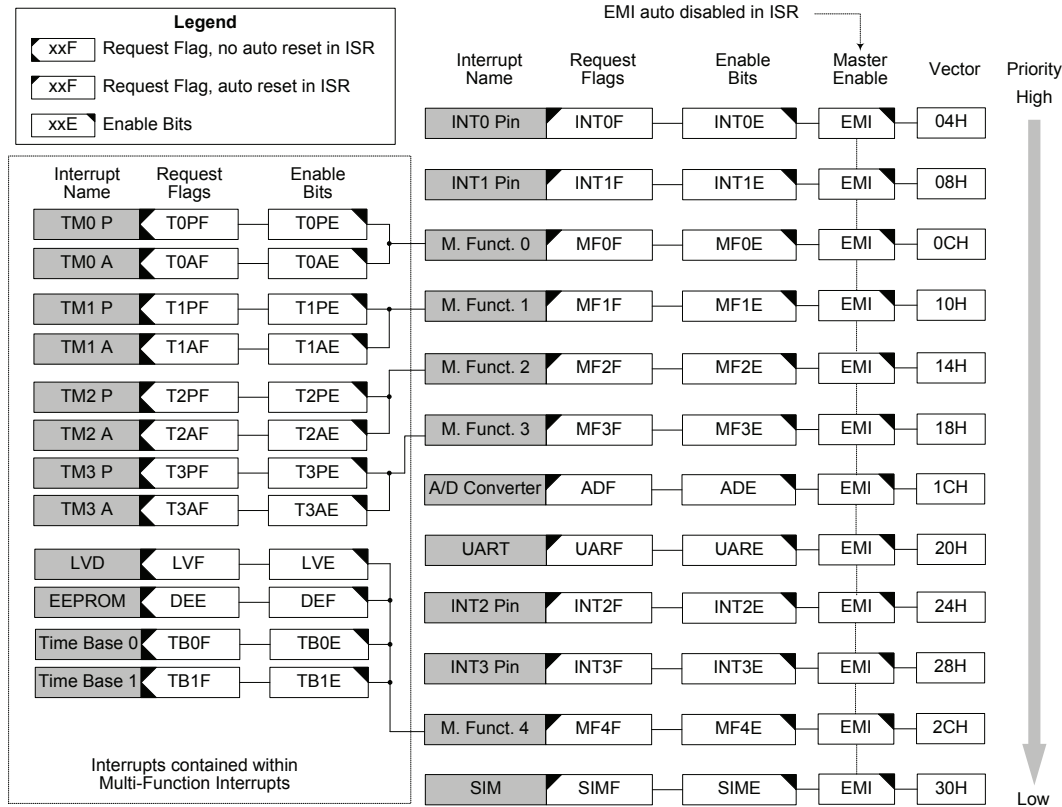

External Interrupt

The external interrupts are controlled by signal transitions on the pins INT0~INT3. An external interrupt request will take place when the external interrupt request flags, INT0F~INT3F, are set, which will occur when a transition, whose type is chosen by the edge select bits, appears on the external interrupt pins. To allow the program to branch to its respective interrupt vector address, the global interrupt enable bit, EMI, and respective external interrupt enable bit, INT0E~INT3E, must first be set. Additionally the correct interrupt edge type must be selected using the INTEG register to enable the external interrupt function and to choose the trigger edge type. As the external interrupt pins are pin-shared with I/O pins, they can only be configured as external interrupt pins if their external interrupt enable bit in the corresponding interrupt register has been set and the external interrupt pin is selected by the corresponding pin-shared function selection bits. The pin must also be setup as an input by setting the corresponding bit in the port control register.

When the interrupt is enabled, the stack is not full and the correct transition type appears on the external interrupt pin, a subroutine call to the external interrupt vector, will take place. When the interrupt is serviced, the external interrupt request flags, INT0F~INT3F, will be automatically reset and the EMI bit will be automatically cleared to disable other interrupts. Note that any pull-high resistor selections on the external interrupt pins will remain valid even if the pin is used as an external interrupt input. The INTEG register is used to select the type of active edge that will trigger the external interrupt. A choice of either rising or falling or both edge types can be chosen to trigger an external interrupt. Note that the INTEG register can also be used to disable the external interrupt function.

A/D Converter Interrupt

The A/D Converter Interrupt is controlled by the termination of an A/D conversion process. An A/D Converter Interrupt request will take place when the A/D Converter Interrupt request flag, ADF, is set, which occurs when the A/D conversion process finishes. To allow the program to branch to its respective interrupt vector address, the global interrupt enable bit, EMI, and A/D Interrupt enable bit, ADE, must first be set. When the interrupt is enabled, the stack is not full and the A/D conversion process has ended, a subroutine call to the A/D Converter Interrupt vector, will take place. When the interrupt is serviced, the A/D Converter Interrupt flag, ADF, will be automatically cleared. The EMI bit will also be automatically cleared to disable other interrupts.

Multi-function Interrupts

Within this device there are three Multi-function interrupts. Unlike the other independent interrupts, these interrupts have no independent source, but rather are formed from other existing interrupt sources, namely the TM Interrupts, EEPROM interrupt LVD interrupt and Time Base interrupts.

A Multi-function interrupt request will take place when any of the Multi-function interrupt request flags, MFnF are set. The Multi-function interrupt flags will be set when any of their included functions generate an interrupt request flag. To allow the program to branch to its respective interrupt vector address, when the Multi-function interrupt is enabled and the stack is not full, and either one of the interrupts contained within each of Multi-function interrupt occurs, a subroutine call to one of the Multi-function interrupt vectors will take place. When the interrupt is serviced, the related Multi-Function request flag will be automatically reset and the EMI bit will be automatically cleared to disable other interrupts.

However, it must be noted that, although the Multi-function Interrupt flags will be automatically reset when the interrupt is serviced, the request flags from the original source of the Multi-function interrupts will not be automatically reset and must be manually reset by the application program.

Serial Interface Module Interrupt

The Serial Interface Module Interrupt is also known as the SIM Interrupt. A SIM Interrupt request will take place when the SIM Interrupt request flag, SIMF, is set, which occurs when a byte of data has been received or transmitted by the SIM interface, an I²C address match or I²C time-out occurrence. To allow the program to branch to its respective interrupt vector address, the global interrupt enable bit, EMI, and the Serial Interface Interrupt enable bit, SIME, must first be set. When the interrupt is enabled, the stack is not full and any of the above described situations occurs, a subroutine call to the SIM interrupt vector, will take place. When the SIM Interface Interrupt is serviced, the interrupt request flag, SIMF, will be automatically reset and the EMI bit will be cleared to disable other interrupts.

UART Interrupt

Several individual UART conditions can generate a UART Interrupt. When these conditions exist, a low pulse will be generated to get the attention of the microcontroller. These conditions are a transmitter data register empty, transmitter idle, receiver data available, receiver overrun, address detect and an RX pin wake-up. To allow the program to branch to the respective interrupt vector addresses, the global interrupt enable bit, EMI, and UART Interrupt enable bit, UARE, must first be set. When the interrupt is enabled, the stack is not full and any of these conditions are created, a subroutine call to the UART Interrupt vector will take place. When the interrupt is serviced, the UART Interrupt flag, UARE, will be automatically cleared. The EMI bit will also be automatically cleared to disable other interrupts. However, the USR register flags will be cleared automatically when certain actions are taken by the UART, the details of which are given in the UART section.

Time Base Interrupts

The Time Base Interrupts are contained within the Multi-function Interrupt. The function of the Time Base Interrupts is to provide regular time signal in the form of an internal interrupt. They are controlled by the overflow signals from their respective timer functions. When these happens their respective interrupt request flags, TB0F or TB1F will be set. To allow the program to branch to their respective interrupt vector addresses, the global interrupt enable bit, EMI and Time Base enable bits, TB0E or TB1E, and associated Multi-function interrupt enable bit, must first be set. When the interrupt is enabled, the stack is not full and the Time Base overflows, a subroutine call to their respective vector locations will take place. When the interrupt is serviced, the EMI bit will be automatically cleared to disable other interrupts, however only the Multi-function interrupt request flag will be also automatically cleared. As the TBnF flag will not be automatically cleared, it has to be cleared by the application program.

The purpose of the Time Base Interrupt is to provide an interrupt signal at fixed time periods. Their clock source originates from the internal clock source f_{TB} , this f_{TB} input clock passes through a divider, the division ratio of which is selected by programming the appropriate bits in the TBC register to obtain longer interrupt periods whose value ranges. The clock source that generates f_{TB} , which in turn controls the Time Base interrupt period, can originate from several different sources, as shown in the System Operating Mode section.

TBC Register

Bit	7	6	5	4	3	2	1	0
Name	TBON	TBCK	TB11	TB10	—	TB02	TB01	TB00
R/W	R/W	R/W	R/W	R/W	—	R/W	R/W	R/W
POR	0	0	1	1	—	1	1	1

Bit 7 **TBON**: Time Base 0 and Time Base 1 Control

0: Disable
1: Enable

Bit 6 **TBCK**: Select f_{TB} Clock

0: f_{TBC}
1: $f_{SYS}/4$

Bit 5~4 **TB11~TB10**: Select Time Base 1 Time-out Period

00: $2^{12}/f_{TB}$
01: $2^{13}/f_{TB}$
10: $2^{14}/f_{TB}$
11: $2^{15}/f_{TB}$

Bit 3 Unimplemented, read as "0"

Bit 2~0 **TB02~TB00**: Select Time Base 0 Time-out Period

000: $2^8/f_{TB}$
001: $2^9/f_{TB}$
010: $2^{10}/f_{TB}$
011: $2^{11}/f_{TB}$
100: $2^{12}/f_{TB}$
101: $2^{13}/f_{TB}$
110: $2^{14}/f_{TB}$
111: $2^{15}/f_{TB}$

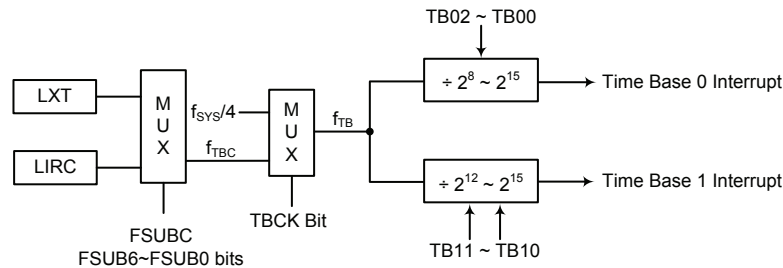

Time Base Interrupt

EEPROM Interrupt

The EEPROM Interrupt is contained within the Multi-function Interrupt. An EEPROM Interrupt request will take place when the EEPROM Interrupt request flag, DEF, is set, which occurs when an EEPROM Write cycle ends. To allow the program to branch to its respective interrupt vector address, the global interrupt enable bit, EMI, and EEPROM Interrupt enable bit, DEE, and associated Multi-function interrupt enable bit, must first be set. When the interrupt is enabled, the stack is not full and an EEPROM Write cycle ends, a subroutine call to the respective EEPROM Interrupt vector will take place. When the EEPROM Interrupt is serviced, the EMI bit will be automatically cleared to disable other interrupts, however only the Multi-function interrupt request flag will be also automatically cleared. As the DEF flag will not be automatically cleared, it has to be cleared by the application program.

LVD Interrupt

The Low Voltage Detector Interrupt is contained within the Multi-function Interrupt. An LVD Interrupt request will take place when the LVD Interrupt request flag, LVF, is set, which occurs when the Low Voltage Detector function detects a low power supply voltage. To allow the program to branch to its respective interrupt vector address, the global interrupt enable bit, EMI, Low Voltage Interrupt enable bit, LVE, and associated Multi-function interrupt enable bit, must first be set. When the interrupt is enabled, the stack is not full and a low voltage condition occurs, a subroutine call to the Multi-function Interrupt vector, will take place. When the Low Voltage Interrupt is serviced, the EMI bit will be automatically cleared to disable other interrupts, however only the Multi-function interrupt request flag will be also automatically cleared. As the LVF flag will not be automatically cleared, it has to be cleared by the application program.

Timer Module Interrupts

Each of the Compact Type TM and Periodic Type TM has two interrupts. All of the TM interrupts are contained within the Multi-function Interrupts. For the Compact Type TM and the Periodic Type TM, each has two interrupt request flags of TnPF and TnAF and two enable bits of TnPE and TnAE. A TM interrupt request will take place when any of the TM request flags are set, a situation which occurs when a TM comparator P or A match situation happens.

To allow the program to branch to its respective interrupt vector address, the global interrupt enable bit, EMI, respective TM Interrupt enable bit, and relevant Multi-function Interrupt enable bit, MFnE, must first be set. When the interrupt is enabled, the stack is not full and a TM comparator match situation occurs, a subroutine call to the relevant Multi-function Interrupt vector locations, will take place. When the TM interrupt is serviced, the EMI bit will be automatically cleared to disable other interrupts, however only the related MFnF flag will be automatically cleared. As the TM interrupt request flags will not be automatically cleared, they have to be cleared by the application program.

Interrupt Wake-up Function

Each of the interrupt functions has the capability of waking up the microcontroller when in the SLEEP or IDLE Mode. A wake-up is generated when an interrupt request flag changes from low to high and is independent of whether the interrupt is enabled or not. Therefore, even though the device is in the SLEEP or IDLE Mode and its system oscillator stopped, situations such as external edge transitions on the external interrupt pins or a low power supply voltage may cause their respective interrupt flag to be set high and consequently generate an interrupt. Care must therefore be taken if spurious wake-up situations are to be avoided. If an interrupt wake-up function is to be disabled then the corresponding interrupt request flag should be set high before the device enters the SLEEP or IDLE Mode. The interrupt enable bits have no effect on the interrupt wake-up function.

Programming Considerations

By disabling the relevant interrupt enable bits, a requested interrupt can be prevented from being serviced, however, once an interrupt request flag is set, it will remain in this condition in the interrupt register until the corresponding interrupt is serviced or until the request flag is cleared by the application program.

Where a certain interrupt is contained within a Multi-function interrupt, then when the interrupt service routine is executed, as only the Multi-function interrupt request flags, MFnF, will be automatically cleared, the individual request flag for the function needs to be cleared by the application program.

It is recommended that programs do not use the "CALL" instruction within the interrupt service subroutine. Interrupts often occur in an unpredictable manner or need to be serviced immediately. If only one stack is left and the interrupt is not well controlled, the original control sequence will be damaged once a CALL subroutine is executed in the interrupt subroutine.

Every interrupt has the capability of waking up the microcontroller when it is in SLEEP or IDLE Mode, the wake up being generated when the interrupt request flag changes from low to high. If it is required to prevent a certain interrupt from waking up the microcontroller then its respective request flag should be first set high before enter SLEEP or IDLE Mode.

As only the Program Counter is pushed onto the stack, then when the interrupt is serviced, if the contents of the accumulator, status register or other registers are altered by the interrupt service program, their contents should be saved to the memory at the beginning of the interrupt service routine. To return from an interrupt subroutine, either a RET or RETI instruction may be executed. The RETI instruction in addition to executing a return to the main program also automatically sets the EMI bit high to allow further interrupts. The RET instruction however only executes a return to the main program leaving the EMI bit in its present zero state and therefore disabling the execution of further interrupts.

Low Voltage Detector – LVD

The device has a Low Voltage Detector function, also known as LVD. This enabled the device to monitor the power supply voltage, V_{DD} , and provide a warning signal should it fall below a certain level. This function may be especially useful in battery applications where the supply voltage will gradually reduce as the battery ages, as it allows an early warning battery low signal to be generated. The Low Voltage Detector also has the capability of generating an interrupt signal.

LVD Register

The Low Voltage Detector function is controlled using a single register with the name LVDC. Three bits in this register, VLVD2~VLVD0, are used to select one of eight fixed voltages below which a low voltage condition will be determined. A low voltage condition is indicated when the LVDO bit is set. If the LVDO bit is low, this indicates that the V_{DD} voltage is above the preset low voltage value. The LVDEN bit is used to control the overall on/off function of the low voltage detector. Setting the bit high will enable the low voltage detector. Clearing the bit to zero will switch off the internal low voltage detector circuits. As the low voltage detector will consume a certain amount of power, it may be desirable to switch off the circuit when not in use, an important consideration in power sensitive battery powered applications.

LVDC Register

Bit	7	6	5	4	3	2	1	0
Name	—	—	LVDO	LVDEN	—	VLVD2	VLVD1	VLVD0
R/W	—	—	R	R/W	—	R/W	R/W	R/W
POR	—	—	0	0	—	0	0	0

- Bit 7~6 Unimplemented, read as "0"
- Bit 5 **LVDO**: LVD Output Flag
 0: No Low Voltage Detect
 1: Low Voltage Detect
- Bit 4 **LVDEN**: Low Voltage Detector Control
 0: Disable
 1: Enable
- Bit 3 Unimplemented, read as "0"
- Bit 2~0 **VLVD2~VLVD0**: Select LVD Voltage
 000: 2.0V
 001: 2.2V
 010: 2.4V
 011: 2.7V
 100: 3.0V
 101: 3.3V
 110: 3.6V
 111: 4.0V

LVD Operation

The Low Voltage Detector function operates by comparing the power supply voltage, V_{DD} voltage with a pre-specified voltage level stored in the LVDC register. This has a range of between 2.0V and 4.0V. When the power supply voltage, V_{DD} voltage falls below this pre-determined value, the LVDO bit will be set high indicating a low power supply voltage condition. The Low Voltage Detector function is supplied by a reference voltage which will be automatically enabled. When the device is powered down, the low voltage detector will remain active if the LVDEN bit is high. After enabling the Low Voltage Detector, a time delay t_{LVDs} should be allowed for the circuitry to stabilise before reading the LVDO bit. Note also that as the V_{DD} voltage may rise and fall rather slowly, at the voltage nears that of V_{LVD} , there may be multiple bit LVDO transitions.

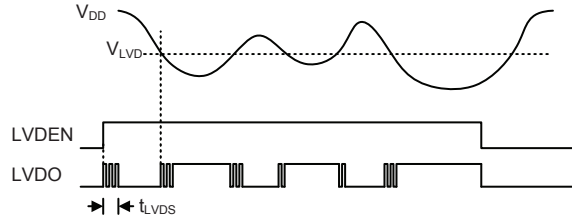

LVD Operation

The Low Voltage Detector interrupt is contained within the Multi-function interrupt, providing an alternative means of low voltage detection, in addition to polling the LVDO bit. The interrupt will only be generated after a delay of t_{LVD} after the LVDO bit has been set high by a low voltage condition. When the device is powered down, the low voltage detector will remain active if the LVDEN bit is high. In this case, the LVF interrupt request flag will be set, causing an interrupt to be generated if V_{DD} voltage falls below the preset LVD voltage. This will cause the device to wake-up from the SLEEP or IDLE Mode, however if the Low Voltage Detector wake up function is not required then the LVF flag should be first set high before the device enters the SLEEP or IDLE Mode. When LVD function is enabled, it is recommended to clear LVD flag first, and then enables interrupt function to avoid mistake action.

Configuration Options

Configuration options refer to certain options within the MCU that are programmed into the device during the programming process. During the development process, these options are selected using the HT-IDE software development tools. As these options are programmed into the device using the hardware programming tools, once they are selected they cannot be changed later using the application program, all options must be defined for proper system function, the details of which are shown in the table.

No.	Options
1	High Speed System Oscillator Selection f_H - HXT or HIRC

Application Circuits

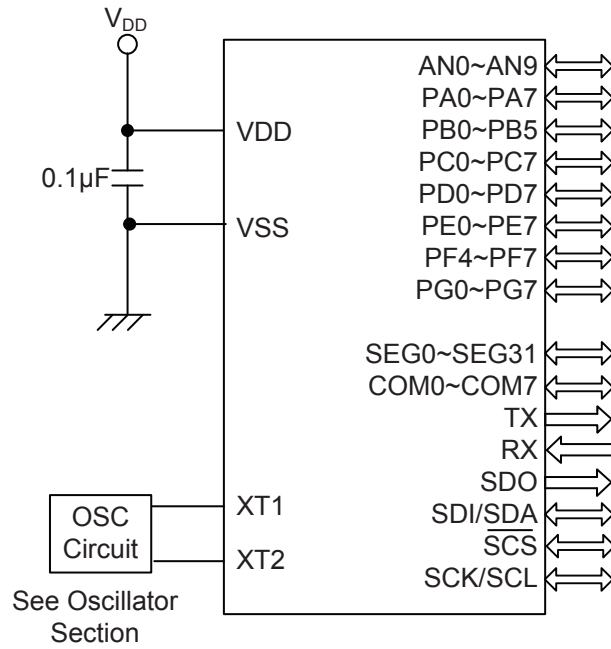

Instruction Set

Introduction

Central to the successful operation of any microcontroller is its instruction set, which is a set of program instruction codes that directs the microcontroller to perform certain operations. In the case of Holtek microcontroller, a comprehensive and flexible set of over 60 instructions is provided to enable programmers to implement their application with the minimum of programming overheads.

For easier understanding of the various instruction codes, they have been subdivided into several functional groupings.

Instruction Timing

Most instructions are implemented within one instruction cycle. The exceptions to this are branch, call, or table read instructions where two instruction cycles are required. One instruction cycle is equal to 4 system clock cycles, therefore in the case of an 8MHz system oscillator, most instructions would be implemented within 0.5 μ s and branch or call instructions would be implemented within 1 μ s. Although instructions which require one more cycle to implement are generally limited to the JMP, CALL, RET, RETI and table read instructions, it is important to realize that any other instructions which involve manipulation of the Program Counter Low register or PCL will also take one more cycle to implement. As instructions which change the contents of the PCL will imply a direct jump to that new address, one more cycle will be required. Examples of such instructions would be "CLR PCL" or "MOV PCL, A". For the case of skip instructions, it must be noted that if the result of the comparison involves a skip operation then this will also take one more cycle, if no skip is involved then only one cycle is required.

Moving and Transferring Data

The transfer of data within the microcontroller program is one of the most frequently used operations. Making use of three kinds of MOV instructions, data can be transferred from registers to the Accumulator and vice-versa as well as being able to move specific immediate data directly into the Accumulator. One of the most important data transfer applications is to receive data from the input ports and transfer data to the output ports.

Arithmetic Operations

The ability to perform certain arithmetic operations and data manipulation is a necessary feature of most microcontroller applications. Within the Holtek microcontroller instruction set are a range of add and subtract instruction mnemonics to enable the necessary arithmetic to be carried out. Care must be taken to ensure correct handling of carry and borrow data when results exceed 255 for addition and less than 0 for subtraction. The increment and decrement instructions INC, INCA, DEC and DECA provide a simple means of increasing or decreasing by a value of one of the values in the destination specified.

Logical and Rotate Operation

The standard logical operations such as AND, OR, XOR and CPL all have their own instruction within the Holtek microcontroller instruction set. As with the case of most instructions involving data manipulation, data must pass through the Accumulator which may involve additional programming steps. In all logical data operations, the zero flag may be set if the result of the operation is zero. Another form of logical data manipulation comes from the rotate instructions such as RR, RL, RRC and RLC which provide a simple means of rotating one Bit right or left. Different rotate instructions exist depending on program requirements. Rotate instructions are useful for serial port programming applications where data can be rotated from an internal register into the Carry Bit from where it can be examined and the necessary serial Bit set high or low. Another application which rotate data operations are used is to implement multiplication and division calculations.

Branches and Control Transfer

Program branching takes the form of either jumps to specified locations using the JMP instruction or to a subroutine using the CALL instruction. They differ in the sense that in the case of a subroutine call, the program must return to the instruction immediately when the subroutine has been carried out. This is done by placing a return instruction "RET" in the subroutine which will cause the program to jump back to the address right after the CALL instruction. In the case of a JMP instruction, the program simply jumps to the desired location. There is no requirement to jump back to the original jumping off point as in the case of the CALL instruction. One special and extremely useful set of branch instructions are the conditional branches. Here a decision is first made regarding the condition of a certain data memory or individual Bits. Depending upon the conditions, the program will continue with the next instruction or skip over it and jump to the following instruction. These instructions are the key to decision making and branching within the program perhaps determined by the condition of certain input switches or by the condition of internal data Bits.

Bit Operations

The ability to provide single Bit operations on Data Memory is an extremely flexible feature of all Holtek microcontrollers. This feature is especially useful for output port Bit programming where individual Bits or port pins can be directly set high or low using either the "SET [m].i" or "CLR [m].i" instructions respectively. The feature removes the need for programmers to first read the 8-Bit output port, manipulate the input data to ensure that other Bits are not changed and then output the port with the correct new data. This read-modify-write process is taken care of automatically when these Bit operation instructions are used.

Table Read Operations

Data storage is normally implemented by using registers. However, when working with large amounts of fixed data, the volume involved often makes it inconvenient to store the fixed data in the Data Memory. To overcome this problem, Holtek microcontrollers allow an area of Program Memory to be set as a table where data can be directly stored. A set of easy to use instructions provides the means by which this fixed data can be referenced and retrieved from the Program Memory.

Other Operations

In addition to the above functional instructions, a range of other instructions also exist such as the "HALT" instruction for Power-down operations and instructions to control the operation of the Watchdog Timer for reliable program operations under extreme electric or electromagnetic environments. For their relevant operations, refer to the functional related sections.

Instruction Set Summary

The instructions related to the data memory access in the following table can be used when the desired data memory is located in Data Memory sector 0.

Table Conventions

x: Bits immediate data
 m: Data Memory address
 A: Accumulator
 i: 0~7 number of bits
 addr: Program memory address

Mnemonic	Description	Cycles	Flag Affected
Arithmetic			
ADD A,[m]	Add Data Memory to ACC	1	Z, C, AC, OV, SC
ADDM A,[m]	Add ACC to Data Memory	1 ^{Note}	Z, C, AC, OV, SC
ADD A,x	Add immediate data to ACC	1	Z, C, AC, OV, SC
ADC A,[m]	Add Data Memory to ACC with Carry	1	Z, C, AC, OV, SC
ADCM A,[m]	Add ACC to Data memory with Carry	1 ^{Note}	Z, C, AC, OV, SC
SUB A,x	Subtract immediate data from the ACC	1	Z, C, AC, OV, SC, CZ
SUB A,[m]	Subtract Data Memory from ACC	1	Z, C, AC, OV, SC, CZ
SUBM A,[m]	Subtract Data Memory from ACC with result in Data Memory	1 ^{Note}	Z, C, AC, OV, SC, CZ
SBC A,x	Subtract immediate data from ACC with Carry	1	Z, C, AC, OV, SC, CZ
SBC A,[m]	Subtract Data Memory from ACC with Carry	1	Z, C, AC, OV, SC, CZ
SBCM A,[m]	Subtract Data Memory from ACC with Carry, result in Data Memory	1 ^{Note}	Z, C, AC, OV, SC, CZ
DAA [m]	Decimal adjust ACC for Addition with result in Data Memory	1 ^{Note}	C
Logic Operation			
AND A,[m]	Logical AND Data Memory to ACC	1	Z
OR A,[m]	Logical OR Data Memory to ACC	1	Z
XOR A,[m]	Logical XOR Data Memory to ACC	1	Z
ANDM A,[m]	Logical AND ACC to Data Memory	1 ^{Note}	Z
ORM A,[m]	Logical OR ACC to Data Memory	1 ^{Note}	Z
XORM A,[m]	Logical XOR ACC to Data Memory	1 ^{Note}	Z
AND A,x	Logical AND immediate Data to ACC	1	Z
OR A,x	Logical OR immediate Data to ACC	1	Z
XOR A,x	Logical XOR immediate Data to ACC	1	Z
CPL [m]	Complement Data Memory	1 ^{Note}	Z
CPLA [m]	Complement Data Memory with result in ACC	1	Z
Increment & Decrement			
INCA [m]	Increment Data Memory with result in ACC	1	Z
INC [m]	Increment Data Memory	1 ^{Note}	Z
DECA [m]	Decrement Data Memory with result in ACC	1	Z
DEC [m]	Decrement Data Memory	1 ^{Note}	Z
Rotate			
RRA [m]	Rotate Data Memory right with result in ACC	1	None
RR [m]	Rotate Data Memory right	1 ^{Note}	None
RRCA [m]	Rotate Data Memory right through Carry with result in ACC	1	C
RRC [m]	Rotate Data Memory right through Carry	1 ^{Note}	C
RLA [m]	Rotate Data Memory left with result in ACC	1	None
RL [m]	Rotate Data Memory left	1 ^{Note}	None
RLCA [m]	Rotate Data Memory left through Carry with result in ACC	1	C
RLC [m]	Rotate Data Memory left through Carry	1 ^{Note}	C

Mnemonic	Description	Cycles	Flag Affected
Data Move			
MOV A,[m]	Move Data Memory to ACC	1	None
MOV [m],A	Move ACC to Data Memory	1 ^{Note}	None
MOV A,x	Move immediate data to ACC	1	None
Bit Operation			
CLR [m].i	Clear bit of Data Memory	1 ^{Note}	None
SET [m].i	Set bit of Data Memory	1 ^{Note}	None
Branch Operation			
JMP addr	Jump unconditionally	2	None
SZ [m]	Skip if Data Memory is zero	1 ^{Note}	None
SZA [m]	Skip if Data Memory is zero with data movement to ACC	1 ^{Note}	None
SZ [m].i	Skip if bit i of Data Memory is zero	1 ^{Note}	None
SNZ [m]	Skip if Data Memory is not zero	1 ^{Note}	None
SNZ [m].i	Skip if bit i of Data Memory is not zero	1 ^{Note}	None
SIZ [m]	Skip if increment Data Memory is zero	1 ^{Note}	None
SDZ [m]	Skip if decrement Data Memory is zero	1 ^{Note}	None
SIZA [m]	Skip if increment Data Memory is zero with result in ACC	1 ^{Note}	None
SDZA [m]	Skip if decrement Data Memory is zero with result in ACC	1 ^{Note}	None
CALL addr	Subroutine call	2	None
RET	Return from subroutine	2	None
RET A,x	Return from subroutine and load immediate data to ACC	2	None
RETI	Return from interrupt	2	None
Table Read Operation			
TABRD [m]	Read table (specific page) to TBLH and Data Memory	2 ^{Note}	None
TABRDL [m]	Read table (last page) to TBLH and Data Memory	2 ^{Note}	None
ITABRD [m]	Increment table pointer TBLP first and Read table to TBLH and Data Memory	2 ^{Note}	None
ITABRDL [m]	Increment table pointer TBLP first and Read table (last page) to TBLH and Data Memory	2 ^{Note}	None
Miscellaneous			
NOP	No operation	1	None
CLR [m]	Clear Data Memory	1 ^{Note}	None
SET [m]	Set Data Memory	1 ^{Note}	None
CLR WDT	Clear Watchdog Timer	1	TO, PDF
SWAP [m]	Swap nibbles of Data Memory	1 ^{Note}	None
SWAPA [m]	Swap nibbles of Data Memory with result in ACC	1	None
HALT	Enter power down mode	1	TO, PDF

Note: 1. For skip instructions, if the result of the comparison involves a skip then up to three cycles are required, if no skip takes place only one cycle is required.

2. Any instruction which changes the contents of the PCL will also require 2 cycles for execution.

3. For the "CLR WDT" instruction the TO and PDF flags may be affected by the execution status. The TO and PDF flags are cleared after the "CLR WDT" instructions is executed. Otherwise the TO and PDF flags remain unchanged.

Extended Instruction Set

The extended instructions are used to support the full range address access for the data memory. When the accessed data memory is located in any data memory sections except sector 0, the extended instruction can be used to access the data memory instead of using the indirect addressing access to improve the CPU firmware performance.

Mnemonic	Description	Cycles	Flag Affected
Arithmetic			
LADD A,[m]	Add Data Memory to ACC	2	Z, C, AC, OV, SC
LADDM A,[m]	Add ACC to Data Memory	2 ^{Note}	Z, C, AC, OV, SC
LADC A,[m]	Add Data Memory to ACC with Carry	2	Z, C, AC, OV, SC
LADCM A,[m]	Add ACC to Data memory with Carry	2 ^{Note}	Z, C, AC, OV, SC
LSUB A,[m]	Subtract Data Memory from ACC	2	Z, C, AC, OV, SC, CZ
LSUBM A,[m]	Subtract Data Memory from ACC with result in Data Memory	2 ^{Note}	Z, C, AC, OV, SC, CZ
LSBC A,[m]	Subtract Data Memory from ACC with Carry	2	Z, C, AC, OV, SC, CZ
LSBCM A,[m]	Subtract Data Memory from ACC with Carry, result in Data Memory	2 ^{Note}	Z, C, AC, OV, SC, CZ
LDAA [m]	Decimal adjust ACC for Addition with result in Data Memory	2 ^{Note}	C
Logic Operation			
LAND A,[m]	Logical AND Data Memory to ACC	2	Z
LOR A,[m]	Logical OR Data Memory to ACC	2	Z
LXOR A,[m]	Logical XOR Data Memory to ACC	2	Z
LANDM A,[m]	Logical AND ACC to Data Memory	2 ^{Note}	Z
LORM A,[m]	Logical OR ACC to Data Memory	2 ^{Note}	Z
LXORM A,[m]	Logical XOR ACC to Data Memory	2 ^{Note}	Z
LCPL [m]	Complement Data Memory	2 ^{Note}	Z
LCPLA [m]	Complement Data Memory with result in ACC	2	Z
Increment & Decrement			
LINCA [m]	Increment Data Memory with result in ACC	2	Z
LINC [m]	Increment Data Memory	2 ^{Note}	Z
LDECA [m]	Decrement Data Memory with result in ACC	2	Z
LDEC [m]	Decrement Data Memory	2 ^{Note}	Z
Rotate			
LRRRA [m]	Rotate Data Memory right with result in ACC	2	None
LRR [m]	Rotate Data Memory right	2 ^{Note}	None
LRRCA [m]	Rotate Data Memory right through Carry with result in ACC	2	C
LRRC [m]	Rotate Data Memory right through Carry	2 ^{Note}	C
LRLA [m]	Rotate Data Memory left with result in ACC	2	None
LRL [m]	Rotate Data Memory left	2 ^{Note}	None
LRLCA [m]	Rotate Data Memory left through Carry with result in ACC	2	C
LRLC [m]	Rotate Data Memory left through Carry	2 ^{Note}	C
Data Move			
LMOV A,[m]	Move Data Memory to ACC	2	None
LMOV [m],A	Move ACC to Data Memory	2 ^{Note}	None
Bit Operation			
LCLR [m].i	Clear bit of Data Memory	2 ^{Note}	None
LSET [m].i	Set bit of Data Memory	2 ^{Note}	None

Mnemonic	Description	Cycles	Flag Affected
Branch			
LSZ [m]	Skip if Data Memory is zero	2 ^{Note}	None
LSZA [m]	Skip if Data Memory is zero with data movement to ACC	2 ^{Note}	None
LSNZ [m]	Skip if Data Memory is not zero	2 ^{Note}	None
LSZ [m].i	Skip if bit i of Data Memory is zero	2 ^{Note}	None
LSNZ [m].i	Skip if bit i of Data Memory is not zero	2 ^{Note}	None
LSIZ [m]	Skip if increment Data Memory is zero	2 ^{Note}	None
LSDZ [m]	Skip if decrement Data Memory is zero	2 ^{Note}	None
LSIZA [m]	Skip if increment Data Memory is zero with result in ACC	2 ^{Note}	None
LSDZA [m]	Skip if decrement Data Memory is zero with result in ACC	2 ^{Note}	None
Table Read			
LTABRD [m]	Read table to TBLH and Data Memory	3 ^{Note}	None
LTABRDL [m]	Read table (last page) to TBLH and Data Memory	3 ^{Note}	None
LITABRD [m]	Increment table pointer TBLP first and Read table to TBLH and Data Memory	3 ^{Note}	None
LITABRDL [m]	Increment table pointer TBLP first and Read table (last page) to TBLH and Data Memory	3 ^{Note}	None
Miscellaneous			
LCLR [m]	Clear Data Memory	2 ^{Note}	None
LSET [m]	Set Data Memory	2 ^{Note}	None
LSWAP [m]	Swap nibbles of Data Memory	2 ^{Note}	None
LSWAPA [m]	Swap nibbles of Data Memory with result in ACC	2	None

Note: 1. For these extended skip instructions, if the result of the comparison involves a skip then up to four cycles are required, if no skip takes place two cycles is required.

2. Any extended instruction which changes the contents of the PCL register will also require three cycles for execution.

Instruction Definition

ADC A,[m]	Add Data Memory to ACC with Carry
Description	The contents of the specified Data Memory, Accumulator and the carry flag are added. The result is stored in the Accumulator.
Operation	$ACC \leftarrow ACC + [m] + C$
Affected flag(s)	OV, Z, AC, C, SC
ADCM A,[m]	Add ACC to Data Memory with Carry
Description	The contents of the specified Data Memory, Accumulator and the carry flag are added. The result is stored in the specified Data Memory.
Operation	$[m] \leftarrow ACC + [m] + C$
Affected flag(s)	OV, Z, AC, C, SC
ADD A,[m]	Add Data Memory to ACC
Description	The contents of the specified Data Memory and the Accumulator are added. The result is stored in the Accumulator.
Operation	$ACC \leftarrow ACC + [m]$
Affected flag(s)	OV, Z, AC, C, SC
ADD A,x	Add immediate data to ACC
Description	The contents of the Accumulator and the specified immediate data are added. The result is stored in the Accumulator.
Operation	$ACC \leftarrow ACC + x$
Affected flag(s)	OV, Z, AC, C, SC
ADDM A,[m]	Add ACC to Data Memory
Description	The contents of the specified Data Memory and the Accumulator are added. The result is stored in the specified Data Memory.
Operation	$[m] \leftarrow ACC + [m]$
Affected flag(s)	OV, Z, AC, C, SC
AND A,[m]	Logical AND Data Memory to ACC
Description	Data in the Accumulator and the specified Data Memory perform a bitwise logical AND operation. The result is stored in the Accumulator.
Operation	$ACC \leftarrow ACC \text{ "AND" } [m]$
Affected flag(s)	Z
AND A,x	Logical AND immediate data to ACC
Description	Data in the Accumulator and the specified immediate data perform a bit wise logical AND operation. The result is stored in the Accumulator.
Operation	$ACC \leftarrow ACC \text{ "AND" } x$
Affected flag(s)	Z
ANDM A,[m]	Logical AND ACC to Data Memory
Description	Data in the specified Data Memory and the Accumulator perform a bitwise logical AND operation. The result is stored in the Data Memory.
Operation	$[m] \leftarrow ACC \text{ "AND" } [m]$
Affected flag(s)	Z

CALL addr	Subroutine call
Description	Unconditionally calls a subroutine at the specified address. The Program Counter then increments by 1 to obtain the address of the next instruction which is then pushed onto the stack. The specified address is then loaded and the program continues execution from this new address. As this instruction requires an additional operation, it is a two cycle instruction.
Operation	Stack ← Program Counter + 1 Program Counter ← addr
Affected flag(s)	None
CLR [m]	Clear Data Memory
Description	Each bit of the specified Data Memory is cleared to 0.
Operation	[m] ← 00H
Affected flag(s)	None
CLR [m].i	Clear bit of Data Memory
Description	Bit i of the specified Data Memory is cleared to 0.
Operation	[m].i ← 0
Affected flag(s)	None
CLR WDT	Clear Watchdog Timer
Description	The TO, PDF flags and the WDT are all cleared.
Operation	WDT cleared TO ← 0 PDF ← 0
Affected flag(s)	TO, PDF
CPL [m]	Complement Data Memory
Description	Each bit of the specified Data Memory is logically complemented (1's complement). Bits which previously contained a 1 are changed to 0 and vice versa.
Operation	[m] ← $\overline{[m]}$
Affected flag(s)	Z
CPLA [m]	Complement Data Memory with result in ACC
Description	Each bit of the specified Data Memory is logically complemented (1's complement). Bits which previously contained a 1 are changed to 0 and vice versa. The complemented result is stored in the Accumulator and the contents of the Data Memory remain unchanged.
Operation	ACC ← $\overline{[m]}$
Affected flag(s)	Z
DAA [m]	Decimal-Adjust ACC for addition with result in Data Memory
Description	Convert the contents of the Accumulator value to a BCD (Binary Coded Decimal) value resulting from the previous addition of two BCD variables. If the low nibble is greater than 9 or if AC flag is set, then a value of 6 will be added to the low nibble. Otherwise the low nibble remains unchanged. If the high nibble is greater than 9 or if the C flag is set, then a value of 6 will be added to the high nibble. Essentially, the decimal conversion is performed by adding 00H, 06H, 60H or 66H depending on the Accumulator and flag conditions. Only the C flag may be affected by this instruction which indicates that if the original BCD sum is greater than 100, it allows multiple precision decimal addition.
Operation	[m] ← ACC + 00H or [m] ← ACC + 06H or [m] ← ACC + 60H or [m] ← ACC + 66H
Affected flag(s)	C

DEC [m]	Decrement Data Memory
Description	Data in the specified Data Memory is decremented by 1.
Operation	$[m] \leftarrow [m] - 1$
Affected flag(s)	Z
DECA [m]	Decrement Data Memory with result in ACC
Description	Data in the specified Data Memory is decremented by 1. The result is stored in the Accumulator. The contents of the Data Memory remain unchanged.
Operation	$ACC \leftarrow [m] - 1$
Affected flag(s)	Z
HALT	Enter power down mode
Description	This instruction stops the program execution and turns off the system clock. The contents of the Data Memory and registers are retained. The WDT and prescaler are cleared. The power down flag PDF is set and the WDT time-out flag TO is cleared.
Operation	$TO \leftarrow 0$ $PDF \leftarrow 1$
Affected flag(s)	TO, PDF
INC [m]	Increment Data Memory
Description	Data in the specified Data Memory is incremented by 1.
Operation	$[m] \leftarrow [m] + 1$
Affected flag(s)	Z
INCA [m]	Increment Data Memory with result in ACC
Description	Data in the specified Data Memory is incremented by 1. The result is stored in the Accumulator. The contents of the Data Memory remain unchanged.
Operation	$ACC \leftarrow [m] + 1$
Affected flag(s)	Z
JMP addr	Jump unconditionally
Description	The contents of the Program Counter are replaced with the specified address. Program execution then continues from this new address. As this requires the insertion of a dummy instruction while the new address is loaded, it is a two cycle instruction.
Operation	Program Counter \leftarrow addr
Affected flag(s)	None
MOV A,[m]	Move Data Memory to ACC
Description	The contents of the specified Data Memory are copied to the Accumulator.
Operation	$ACC \leftarrow [m]$
Affected flag(s)	None
MOV A,x	Move immediate data to ACC
Description	The immediate data specified is loaded into the Accumulator.
Operation	$ACC \leftarrow x$
Affected flag(s)	None
MOV [m],A	Move ACC to Data Memory
Description	The contents of the Accumulator are copied to the specified Data Memory.
Operation	$[m] \leftarrow ACC$
Affected flag(s)	None

NOP	No operation
Description	No operation is performed. Execution continues with the next instruction.
Operation	No operation
Affected flag(s)	None
OR A,[m]	Logical OR Data Memory to ACC
Description	Data in the Accumulator and the specified Data Memory perform a bitwise logical OR operation. The result is stored in the Accumulator.
Operation	ACC ← ACC "OR" [m]
Affected flag(s)	Z
OR A,x	Logical OR immediate data to ACC
Description	Data in the Accumulator and the specified immediate data perform a bitwise logical OR operation. The result is stored in the Accumulator.
Operation	ACC ← ACC "OR" x
Affected flag(s)	Z
ORM A,[m]	Logical OR ACC to Data Memory
Description	Data in the specified Data Memory and the Accumulator perform a bitwise logical OR operation. The result is stored in the Data Memory.
Operation	[m] ← ACC "OR" [m]
Affected flag(s)	Z
RET	Return from subroutine
Description	The Program Counter is restored from the stack. Program execution continues at the restored address.
Operation	Program Counter ← Stack
Affected flag(s)	None
RET A,x	Return from subroutine and load immediate data to ACC
Description	The Program Counter is restored from the stack and the Accumulator loaded with the specified immediate data. Program execution continues at the restored address.
Operation	Program Counter ← Stack ACC ← x
Affected flag(s)	None
RETI	Return from interrupt
Description	The Program Counter is restored from the stack and the interrupts are re-enabled by setting the EMI bit. EMI is the master interrupt global enable bit. If an interrupt was pending when the RETI instruction is executed, the pending Interrupt routine will be processed before returning to the main program.
Operation	Program Counter ← Stack EMI ← 1
Affected flag(s)	None
RL [m]	Rotate Data Memory left
Description	The contents of the specified Data Memory are rotated left by 1 bit with bit 7 rotated into bit 0.
Operation	[m].(i+1) ← [m].i; (i=0~6) [m].0 ← [m].7
Affected flag(s)	None

RLA [m]	Rotate Data Memory left with result in ACC
Description	The contents of the specified Data Memory are rotated left by 1 bit with bit 7 rotated into bit 0. The rotated result is stored in the Accumulator and the contents of the Data Memory remain unchanged.
Operation	$ACC.(i+1) \leftarrow [m].i; (i=0\sim6)$ $ACC.0 \leftarrow [m].7$
Affected flag(s)	None
RLC [m]	Rotate Data Memory left through Carry
Description	The contents of the specified Data Memory and the carry flag are rotated left by 1 bit. Bit 7 replaces the Carry bit and the original carry flag is rotated into bit 0.
Operation	$[m].(i+1) \leftarrow [m].i; (i=0\sim6)$ $[m].0 \leftarrow C$ $C \leftarrow [m].7$
Affected flag(s)	C
RLCA [m]	Rotate Data Memory left through Carry with result in ACC
Description	Data in the specified Data Memory and the carry flag are rotated left by 1 bit. Bit 7 replaces the Carry bit and the original carry flag is rotated into the bit 0. The rotated result is stored in the Accumulator and the contents of the Data Memory remain unchanged.
Operation	$ACC.(i+1) \leftarrow [m].i; (i=0\sim6)$ $ACC.0 \leftarrow C$ $C \leftarrow [m].7$
Affected flag(s)	C
RR [m]	Rotate Data Memory right
Description	The contents of the specified Data Memory are rotated right by 1 bit with bit 0 rotated into bit 7.
Operation	$[m].i \leftarrow [m].(i+1); (i=0\sim6)$ $[m].7 \leftarrow [m].0$
Affected flag(s)	None
RRA [m]	Rotate Data Memory right with result in ACC
Description	Data in the specified Data Memory is rotated right by 1 bit with bit 0 rotated into bit 7. The rotated result is stored in the Accumulator and the contents of the Data Memory remain unchanged.
Operation	$ACC.i \leftarrow [m].(i+1); (i=0\sim6)$ $ACC.7 \leftarrow [m].0$
Affected flag(s)	None
RRC [m]	Rotate Data Memory right through Carry
Description	The contents of the specified Data Memory and the carry flag are rotated right by 1 bit. Bit 0 replaces the Carry bit and the original carry flag is rotated into bit 7.
Operation	$[m].i \leftarrow [m].(i+1); (i=0\sim6)$ $[m].7 \leftarrow C$ $C \leftarrow [m].0$
Affected flag(s)	C

RRCA [m]	Rotate Data Memory right through Carry with result in ACC
Description	Data in the specified Data Memory and the carry flag are rotated right by 1 bit. Bit 0 replaces the Carry bit and the original carry flag is rotated into bit 7. The rotated result is stored in the Accumulator and the contents of the Data Memory remain unchanged.
Operation	$ACC.i \leftarrow [m].(i+1); (i=0\sim6)$ $ACC.7 \leftarrow C$ $C \leftarrow [m].0$
Affected flag(s)	C
SBC A,[m]	Subtract Data Memory from ACC with Carry
Description	The contents of the specified Data Memory and the complement of the carry flag are subtracted from the Accumulator. The result is stored in the Accumulator. Note that if the result of subtraction is negative, the C flag will be cleared to 0, otherwise if the result is positive or zero, the C flag will be set to 1.
Operation	$ACC \leftarrow ACC - [m] - C$
Affected flag(s)	OV, Z, AC, C, SC, CZ
SBC A, x	Subtract immediate data from ACC with Carry
Description	The immediate data and the complement of the carry flag are subtracted from the Accumulator. The result is stored in the Accumulator. Note that if the result of subtraction is negative, the C flag will be cleared to 0, otherwise if the result is positive or zero, the C flag will be set to 1.
Operation	$ACC \leftarrow ACC - [m] - \bar{C}$
Affected flag(s)	OV, Z, AC, C, SC, CZ
SBCM A,[m]	Subtract Data Memory from ACC with Carry and result in Data Memory
Description	The contents of the specified Data Memory and the complement of the carry flag are subtracted from the Accumulator. The result is stored in the Data Memory. Note that if the result of subtraction is negative, the C flag will be cleared to 0, otherwise if the result is positive or zero, the C flag will be set to 1.
Operation	$[m] \leftarrow ACC - [m] - C$
Affected flag(s)	OV, Z, AC, C, SC, CZ
SDZ [m]	Skip if decrement Data Memory is 0
Description	The contents of the specified Data Memory are first decremented by 1. If the result is 0 the following instruction is skipped. As this requires the insertion of a dummy instruction while the next instruction is fetched, it is a two cycle instruction. If the result is not 0 the program proceeds with the following instruction.
Operation	$[m] \leftarrow [m] - 1$ Skip if $[m]=0$
Affected flag(s)	None
SDZA [m]	Skip if decrement Data Memory is zero with result in ACC
Description	The contents of the specified Data Memory are first decremented by 1. If the result is 0, the following instruction is skipped. The result is stored in the Accumulator but the specified Data Memory contents remain unchanged. As this requires the insertion of a dummy instruction while the next instruction is fetched, it is a two cycle instruction. If the result is not 0, the program proceeds with the following instruction.
Operation	$ACC \leftarrow [m] - 1$ Skip if $ACC=0$
Affected flag(s)	None

SET [m]	Set Data Memory
Description	Each bit of the specified Data Memory is set to 1.
Operation	$[m] \leftarrow FFH$
Affected flag(s)	None
SET [m].i	Set bit of Data Memory
Description	Bit i of the specified Data Memory is set to 1.
Operation	$[m].i \leftarrow 1$
Affected flag(s)	None
SIZ [m]	Skip if increment Data Memory is 0
Description	The contents of the specified Data Memory are first incremented by 1. If the result is 0, the following instruction is skipped. As this requires the insertion of a dummy instruction while the next instruction is fetched, it is a two cycle instruction. If the result is not 0 the program proceeds with the following instruction.
Operation	$[m] \leftarrow [m] + 1$ Skip if $[m]=0$
Affected flag(s)	None
SIZA [m]	Skip if increment Data Memory is zero with result in ACC
Description	The contents of the specified Data Memory are first incremented by 1. If the result is 0, the following instruction is skipped. The result is stored in the Accumulator but the specified Data Memory contents remain unchanged. As this requires the insertion of a dummy instruction while the next instruction is fetched, it is a two cycle instruction. If the result is not 0 the program proceeds with the following instruction.
Operation	$ACC \leftarrow [m] + 1$ Skip if $ACC=0$
Affected flag(s)	None
SNZ [m].i	Skip if Data Memory is not 0
Description	If the specified Data Memory is not 0, the following instruction is skipped. As this requires the insertion of a dummy instruction while the next instruction is fetched, it is a two cycle instruction. If the result is 0 the program proceeds with the following instruction.
Operation	Skip if $[m].i \neq 0$
Affected flag(s)	None
SNZ [m]	Skip if Data Memory is not 0
Description	If the specified Data Memory is not 0, the following instruction is skipped. As this requires the insertion of a dummy instruction while the next instruction is fetched, it is a two cycle instruction. If the result is 0 the program proceeds with the following instruction.
Operation	Skip if $[m] \neq 0$
Affected flag(s)	None
SUB A,[m]	Subtract Data Memory from ACC
Description	The specified Data Memory is subtracted from the contents of the Accumulator. The result is stored in the Accumulator. Note that if the result of subtraction is negative, the C flag will be cleared to 0, otherwise if the result is positive or zero, the C flag will be set to 1.
Operation	$ACC \leftarrow ACC - [m]$
Affected flag(s)	OV, Z, AC, C, SC, CZ

SUBM A,[m]	Subtract Data Memory from ACC with result in Data Memory
Description	The specified Data Memory is subtracted from the contents of the Accumulator. The result is stored in the Data Memory. Note that if the result of subtraction is negative, the C flag will be cleared to 0, otherwise if the result is positive or zero, the C flag will be set to 1.
Operation	$[m] \leftarrow ACC - [m]$
Affected flag(s)	OV, Z, AC, C, SC, CZ
SUB A,x	Subtract immediate data from ACC
Description	The immediate data specified by the code is subtracted from the contents of the Accumulator. The result is stored in the Accumulator. Note that if the result of subtraction is negative, the C flag will be cleared to 0, otherwise if the result is positive or zero, the C flag will be set to 1.
Operation	$ACC \leftarrow ACC - x$
Affected flag(s)	OV, Z, AC, C, SC, CZ
SWAP [m]	Swap nibbles of Data Memory
Description	The low-order and high-order nibbles of the specified Data Memory are interchanged.
Operation	$[m].3 \sim [m].0 \leftrightarrow [m].7 \sim [m].4$
Affected flag(s)	None
SWAPA [m]	Swap nibbles of Data Memory with result in ACC
Description	The low-order and high-order nibbles of the specified Data Memory are interchanged. The result is stored in the Accumulator. The contents of the Data Memory remain unchanged.
Operation	$ACC.3 \sim ACC.0 \leftarrow [m].7 \sim [m].4$ $ACC.7 \sim ACC.4 \leftarrow [m].3 \sim [m].0$
Affected flag(s)	None
SZ [m]	Skip if Data Memory is 0
Description	If the contents of the specified Data Memory is 0, the following instruction is skipped. As this requires the insertion of a dummy instruction while the next instruction is fetched, it is a two cycle instruction. If the result is not 0 the program proceeds with the following instruction.
Operation	Skip if $[m]=0$
Affected flag(s)	None
SZA [m]	Skip if Data Memory is 0 with data movement to ACC
Description	The contents of the specified Data Memory are copied to the Accumulator. If the value is zero, the following instruction is skipped. As this requires the insertion of a dummy instruction while the next instruction is fetched, it is a two cycle instruction. If the result is not 0 the program proceeds with the following instruction.
Operation	$ACC \leftarrow [m]$ Skip if $[m]=0$
Affected flag(s)	None
SZ [m].i	Skip if bit i of Data Memory is 0
Description	If bit i of the specified Data Memory is 0, the following instruction is skipped. As this requires the insertion of a dummy instruction while the next instruction is fetched, it is a two cycle instruction. If the result is not 0, the program proceeds with the following instruction.
Operation	Skip if $[m].i=0$
Affected flag(s)	None

TABRD [m]	Read table (specific page) to TBLH and Data Memory
Description	The low byte of the program code (specific page) addressed by the table pointer pair (TBLP and TBHP) is moved to the specified Data Memory and the high byte moved to TBLH.
Operation	[m] ← program code (low byte) TBLH ← program code (high byte)
Affected flag(s)	None
TABRDL [m]	Read table (last page) to TBLH and Data Memory
Description	The low byte of the program code (last page) addressed by the table pointer (TBLP) is moved to the specified Data Memory and the high byte moved to TBLH.
Operation	[m] ← program code (low byte) TBLH ← program code (high byte)
Affected flag(s)	None
ITABRD [m]	Increment table pointer low byte first and read table to TBLH and Data Memory
Description	Increment table pointer low byte, TBLP, first and then the program code addressed by the table pointer (TBHP and TBLP) is moved to the specified Data Memory and the high byte moved to TBLH.
Operation	[m] ← program code (low byte) TBLH ← program code (high byte)
Affected flag(s)	None
ITABRDL [m]	Increment table pointer low byte first and read table (last page) to TBLH and Data Memory
Description	Increment table pointer low byte, TBLP, first and then the low byte of the program code (last page) addressed by the table pointer (TBLP) is moved to the specified Data Memory and the high byte moved to TBLH.
Operation	[m] ← program code (low byte) TBLH ← program code (high byte)
Affected flag(s)	None
XOR A,[m]	Logical XOR Data Memory to ACC
Description	Data in the Accumulator and the specified Data Memory perform a bitwise logical XOR operation. The result is stored in the Accumulator.
Operation	ACC ← ACC "XOR" [m]
Affected flag(s)	Z
XORM A,[m]	Logical XOR ACC to Data Memory
Description	Data in the specified Data Memory and the Accumulator perform a bitwise logical XOR operation. The result is stored in the Data Memory.
Operation	[m] ← ACC "XOR" [m]
Affected flag(s)	Z
XOR A,x	Logical XOR immediate data to ACC
Description	Data in the Accumulator and the specified immediate data perform a bitwise logical XOR operation. The result is stored in the Accumulator.
Operation	ACC ← ACC "XOR" x
Affected flag(s)	Z

Extended Instruction Definition

The extended instructions are used to directly access the data stored in any data memory sections.

LADC A,[m]	Add Data Memory to ACC with Carry
Description	The contents of the specified Data Memory, Accumulator and the carry flag are added. The result is stored in the Accumulator.
Operation	$ACC \leftarrow ACC + [m] + C$
Affected flag(s)	OV, Z, AC, C, SC
LADCM A,[m]	Add ACC to Data Memory with Carry
Description	The contents of the specified Data Memory, Accumulator and the carry flag are added. The result is stored in the specified Data Memory.
Operation	$[m] \leftarrow ACC + [m] + C$
Affected flag(s)	OV, Z, AC, C, SC
LADD A,[m]	Add Data Memory to ACC
Description	The contents of the specified Data Memory and the Accumulator are added. The result is stored in the Accumulator.
Operation	$ACC \leftarrow ACC + [m]$
Affected flag(s)	OV, Z, AC, C, SC
LADDM A,[m]	Add ACC to Data Memory
Description	The contents of the specified Data Memory and the Accumulator are added. The result is stored in the specified Data Memory.
Operation	$[m] \leftarrow ACC + [m]$
Affected flag(s)	OV, Z, AC, C, SC
LAND A,[m]	Logical AND Data Memory to ACC
Description	Data in the Accumulator and the specified Data Memory perform a bitwise logical AND operation. The result is stored in the Accumulator.
Operation	$ACC \leftarrow ACC \text{ "AND" } [m]$
Affected flag(s)	Z
LANDM A,[m]	Logical AND ACC to Data Memory
Description	Data in the specified Data Memory and the Accumulator perform a bitwise logical AND operation. The result is stored in the Data Memory.
Operation	$[m] \leftarrow ACC \text{ "AND" } [m]$
Affected flag(s)	Z
LCLR [m]	Clear Data Memory
Description	Each bit of the specified Data Memory is cleared to 0.
Operation	$[m] \leftarrow 00H$
Affected flag(s)	None
LCLR [m].i	Clear bit of Data Memory
Description	Bit i of the specified Data Memory is cleared to 0.
Operation	$[m].i \leftarrow 0$
Affected flag(s)	None

LCPL [m]	Complement Data Memory
Description	Each bit of the specified Data Memory is logically complemented (1's complement). Bits which previously contained a 1 are changed to 0 and vice versa.
Operation	$[m] \leftarrow \overline{[m]}$
Affected flag(s)	Z
LCPLA [m]	Complement Data Memory with result in ACC
Description	Each bit of the specified Data Memory is logically complemented (1's complement). Bits which previously contained a 1 are changed to 0 and vice versa. The complemented result is stored in the Accumulator and the contents of the Data Memory remain unchanged.
Operation	$ACC \leftarrow \overline{[m]}$
Affected flag(s)	Z
LDAA [m]	Decimal-Adjust ACC for addition with result in Data Memory
Description	Convert the contents of the Accumulator value to a BCD (Binary Coded Decimal) value resulting from the previous addition of two BCD variables. If the low nibble is greater than 9 or if AC flag is set, then a value of 6 will be added to the low nibble. Otherwise the low nibble remains unchanged. If the high nibble is greater than 9 or if the C flag is set, then a value of 6 will be added to the high nibble. Essentially, the decimal conversion is performed by adding 00H, 06H, 60H or 66H depending on the Accumulator and flag conditions. Only the C flag may be affected by this instruction which indicates that if the original BCD sum is greater than 100, it allows multiple precision decimal addition.
Operation	$[m] \leftarrow ACC + 00H$ or $[m] \leftarrow ACC + 06H$ or $[m] \leftarrow ACC + 60H$ or $[m] \leftarrow ACC + 66H$
Affected flag(s)	C
LDEC [m]	Decrement Data Memory
Description	Data in the specified Data Memory is decremented by 1.
Operation	$[m] \leftarrow [m] - 1$
Affected flag(s)	Z
LDECA [m]	Decrement Data Memory with result in ACC
Description	Data in the specified Data Memory is decremented by 1. The result is stored in the Accumulator. The contents of the Data Memory remain unchanged.
Operation	$ACC \leftarrow [m] - 1$
Affected flag(s)	Z
LINC [m]	Increment Data Memory
Description	Data in the specified Data Memory is incremented by 1.
Operation	$[m] \leftarrow [m] + 1$
Affected flag(s)	Z
LINCA [m]	Increment Data Memory with result in ACC
Description	Data in the specified Data Memory is incremented by 1. The result is stored in the Accumulator. The contents of the Data Memory remain unchanged.
Operation	$ACC \leftarrow [m] + 1$
Affected flag(s)	Z

LMOV A,[m]	Move Data Memory to ACC
Description	The contents of the specified Data Memory are copied to the Accumulator.
Operation	$ACC \leftarrow [m]$
Affected flag(s)	None
LMOV [m],A	Move ACC to Data Memory
Description	The contents of the Accumulator are copied to the specified Data Memory.
Operation	$[m] \leftarrow ACC$
Affected flag(s)	None
LOR A,[m]	Logical OR Data Memory to ACC
Description	Data in the Accumulator and the specified Data Memory perform a bitwise logical OR operation. The result is stored in the Accumulator.
Operation	$ACC \leftarrow ACC \text{ "OR" } [m]$
Affected flag(s)	Z
LORM A,[m]	Logical OR ACC to Data Memory
Description	Data in the specified Data Memory and the Accumulator perform a bitwise logical OR operation. The result is stored in the Data Memory.
Operation	$[m] \leftarrow ACC \text{ "OR" } [m]$
Affected flag(s)	Z
LRL [m]	Rotate Data Memory left
Description	The contents of the specified Data Memory are rotated left by 1 bit with bit 7 rotated into bit 0.
Operation	$[m].(i+1) \leftarrow [m].i; (i=0\sim6)$ $[m].0 \leftarrow [m].7$
Affected flag(s)	None
LRLA [m]	Rotate Data Memory left with result in ACC
Description	The contents of the specified Data Memory are rotated left by 1 bit with bit 7 rotated into bit 0. The rotated result is stored in the Accumulator and the contents of the Data Memory remain unchanged.
Operation	$ACC.(i+1) \leftarrow [m].i; (i=0\sim6)$ $ACC.0 \leftarrow [m].7$
Affected flag(s)	None
LRLC [m]	Rotate Data Memory left through Carry
Description	The contents of the specified Data Memory and the carry flag are rotated left by 1 bit. Bit 7 replaces the Carry bit and the original carry flag is rotated into bit 0.
Operation	$[m].(i+1) \leftarrow [m].i; (i=0\sim6)$ $[m].0 \leftarrow C$ $C \leftarrow [m].7$
Affected flag(s)	C
LRLCA [m]	Rotate Data Memory left through Carry with result in ACC
Description	Data in the specified Data Memory and the carry flag are rotated left by 1 bit. Bit 7 replaces the Carry bit and the original carry flag is rotated into the bit 0. The rotated result is stored in the Accumulator and the contents of the Data Memory remain unchanged.
Operation	$ACC.(i+1) \leftarrow [m].i; (i=0\sim6)$ $ACC.0 \leftarrow C$ $C \leftarrow [m].7$
Affected flag(s)	C

LRR [m]	Rotate Data Memory right
Description	The contents of the specified Data Memory are rotated right by 1 bit with bit 0 rotated into bit 7.
Operation	$[m].i \leftarrow [m].(i+1); (i=0\sim6)$ $[m].7 \leftarrow [m].0$
Affected flag(s)	None
LRRRA [m]	Rotate Data Memory right with result in ACC
Description	Data in the specified Data Memory is rotated right by 1 bit with bit 0 rotated into bit 7. The rotated result is stored in the Accumulator and the contents of the Data Memory remain unchanged.
Operation	$ACC.i \leftarrow [m].(i+1); (i=0\sim6)$ $ACC.7 \leftarrow [m].0$
Affected flag(s)	None
LRRC [m]	Rotate Data Memory right through Carry
Description	The contents of the specified Data Memory and the carry flag are rotated right by 1 bit. Bit 0 replaces the Carry bit and the original carry flag is rotated into bit 7.
Operation	$[m].i \leftarrow [m].(i+1); (i=0\sim6)$ $[m].7 \leftarrow C$ $C \leftarrow [m].0$
Affected flag(s)	C
LRRCA [m]	Rotate Data Memory right through Carry with result in ACC
Description	Data in the specified Data Memory and the carry flag are rotated right by 1 bit. Bit 0 replaces the Carry bit and the original carry flag is rotated into bit 7. The rotated result is stored in the Accumulator and the contents of the Data Memory remain unchanged.
Operation	$ACC.i \leftarrow [m].(i+1); (i=0\sim6)$ $ACC.7 \leftarrow C$ $C \leftarrow [m].0$
Affected flag(s)	C
LSBC A,[m]	Subtract Data Memory from ACC with Carry
Description	The contents of the specified Data Memory and the complement of the carry flag are subtracted from the Accumulator. The result is stored in the Accumulator. Note that if the result of subtraction is negative, the C flag will be cleared to 0, otherwise if the result is positive or zero, the C flag will be set to 1.
Operation	$ACC \leftarrow ACC - [m] - C$
Affected flag(s)	OV, Z, AC, C, SC, CZ
LSBCM A,[m]	Subtract Data Memory from ACC with Carry and result in Data Memory
Description	The contents of the specified Data Memory and the complement of the carry flag are subtracted from the Accumulator. The result is stored in the Data Memory. Note that if the result of subtraction is negative, the C flag will be cleared to 0, otherwise if the result is positive or zero, the C flag will be set to 1.
Operation	$[m] \leftarrow ACC - [m] - C$
Affected flag(s)	OV, Z, AC, C, SC, CZ

LSDZ [m]	Skip if decrement Data Memory is 0
Description	The contents of the specified Data Memory are first decremented by 1. If the result is 0 the following instruction is skipped. As this requires the insertion of a dummy instruction while the next instruction is fetched, it is a two cycle instruction. If the result is not 0 the program proceeds with the following instruction.
Operation	$[m] \leftarrow [m] - 1$ Skip if $[m]=0$
Affected flag(s)	None
LSDZA [m]	Skip if decrement Data Memory is zero with result in ACC
Description	The contents of the specified Data Memory are first decremented by 1. If the result is 0, the following instruction is skipped. The result is stored in the Accumulator but the specified Data Memory contents remain unchanged. As this requires the insertion of a dummy instruction while the next instruction is fetched, it is a two cycle instruction. If the result is not 0, the program proceeds with the following instruction.
Operation	$ACC \leftarrow [m] - 1$ Skip if $ACC=0$
Affected flag(s)	None
LSET [m]	Set Data Memory
Description	Each bit of the specified Data Memory is set to 1.
Operation	$[m] \leftarrow FFH$
Affected flag(s)	None
LSET [m].i	Set bit of Data Memory
Description	Bit i of the specified Data Memory is set to 1.
Operation	$[m].i \leftarrow 1$
Affected flag(s)	None
LSIZ [m]	Skip if increment Data Memory is 0
Description	The contents of the specified Data Memory are first incremented by 1. If the result is 0, the following instruction is skipped. As this requires the insertion of a dummy instruction while the next instruction is fetched, it is a two cycle instruction. If the result is not 0 the program proceeds with the following instruction.
Operation	$[m] \leftarrow [m] + 1$ Skip if $[m]=0$
Affected flag(s)	None
LSIZA [m]	Skip if increment Data Memory is zero with result in ACC
Description	The contents of the specified Data Memory are first incremented by 1. If the result is 0, the following instruction is skipped. The result is stored in the Accumulator but the specified Data Memory contents remain unchanged. As this requires the insertion of a dummy instruction while the next instruction is fetched, it is a two cycle instruction. If the result is not 0 the program proceeds with the following instruction.
Operation	$ACC \leftarrow [m] + 1$ Skip if $ACC=0$
Affected flag(s)	None
LSNZ [m].i	Skip if Data Memory is not 0
Description	If the specified Data Memory is not 0, the following instruction is skipped. As this requires the insertion of a dummy instruction while the next instruction is fetched, it is a two cycle instruction. If the result is 0 the program proceeds with the following instruction.
Operation	Skip if $[m].i \neq 0$
Affected flag(s)	None

LSNZ [m]	Skip if Data Memory is not 0
Description	If the content of the specified Data Memory is not 0, the following instruction is skipped. As this requires the insertion of a dummy instruction while the next instruction is fetched, it is a two cycle instruction. If the result is 0 the program proceeds with the following instruction.
Operation	Skip if [m] ≠ 0
Affected flag(s)	None
LSUB A,[m]	Subtract Data Memory from ACC
Description	The specified Data Memory is subtracted from the contents of the Accumulator. The result is stored in the Accumulator. Note that if the result of subtraction is negative, the C flag will be cleared to 0, otherwise if the result is positive or zero, the C flag will be set to 1.
Operation	ACC ← ACC – [m]
Affected flag(s)	OV, Z, AC, C, SC, CZ
LSUBM A,[m]	Subtract Data Memory from ACC with result in Data Memory
Description	The specified Data Memory is subtracted from the contents of the Accumulator. The result is stored in the Data Memory. Note that if the result of subtraction is negative, the C flag will be cleared to 0, otherwise if the result is positive or zero, the C flag will be set to 1.
Operation	[m] ← ACC – [m]
Affected flag(s)	OV, Z, AC, C, SC, CZ
LSWAP [m]	Swap nibbles of Data Memory
Description	The low-order and high-order nibbles of the specified Data Memory are interchanged.
Operation	[m].3~[m].0 ↔ [m].7~[m].4
Affected flag(s)	None
LSWAPA [m]	Swap nibbles of Data Memory with result in ACC
Description	The low-order and high-order nibbles of the specified Data Memory are interchanged. The result is stored in the Accumulator. The contents of the Data Memory remain unchanged.
Operation	ACC.3~ACC.0 ← [m].7~[m].4 ACC.7~ACC.4 ← [m].3~[m].0
Affected flag(s)	None
LSZ [m]	Skip if Data Memory is 0
Description	If the contents of the specified Data Memory is 0, the following instruction is skipped. As this requires the insertion of a dummy instruction while the next instruction is fetched, it is a two cycle instruction. If the result is not 0 the program proceeds with the following instruction.
Operation	Skip if [m]=0
Affected flag(s)	None
LSZA [m]	Skip if Data Memory is 0 with data movement to ACC
Description	The contents of the specified Data Memory are copied to the Accumulator. If the value is zero, the following instruction is skipped. As this requires the insertion of a dummy instruction while the next instruction is fetched, it is a two cycle instruction. If the result is not 0 the program proceeds with the following instruction.
Operation	ACC ← [m] Skip if [m]=0
Affected flag(s)	None

LSZ [m].i	Skip if bit i of Data Memory is 0
Description	If bit i of the specified Data Memory is 0, the following instruction is skipped. As this requires the insertion of a dummy instruction while the next instruction is fetched, it is a two cycle instruction. If the result is not 0, the program proceeds with the following instruction.
Operation	Skip if [m].i=0
Affected flag(s)	None
LTABRD [m]	Read table (current page) to TBLH and Data Memory
Description	The low byte of the program code (current page) addressed by the table pointer (TBLP) is moved to the specified Data Memory and the high byte moved to TBLH.
Operation	[m] ← program code (low byte) TBLH ← program code (high byte)
Affected flag(s)	None
LTABRDL [m]	Read table (last page) to TBLH and Data Memory
Description	The low byte of the program code (last page) addressed by the table pointer (TBLP) is moved to the specified Data Memory and the high byte moved to TBLH.
Operation	[m] ← program code (low byte) TBLH ← program code (high byte)
Affected flag(s)	None
LITABRD [m]	Increment table pointer low byte first and read table to TBLH and Data Memory
Description	Increment table pointer low byte, TBLP, first and then the program code addressed by the table pointer (TBLP and TBLP) is moved to the specified Data Memory and the high byte moved to TBLH.
Operation	[m] ← program code (low byte) TBLH ← program code (high byte)
Affected flag(s)	None
LITABRDL [m]	Increment table pointer low byte first and read table (last page) to TBLH and Data Memory
Description	Increment table pointer low byte, TBLP, first and then the low byte of the program code (last page) addressed by the table pointer (TBLP) is moved to the specified Data Memory and the high byte moved to TBLH.
Operation	[m] ← program code (low byte) TBLH ← program code (high byte)
Affected flag(s)	None
LXOR A,[m]	Logical XOR Data Memory to ACC
Description	Data in the Accumulator and the specified Data Memory perform a bitwise logical XOR operation. The result is stored in the Accumulator.
Operation	ACC ← ACC "XOR" [m]
Affected flag(s)	Z
LXORM A,[m]	Logical XOR ACC to Data Memory
Description	Data in the specified Data Memory and the Accumulator perform a bitwise logical XOR operation. The result is stored in the Data Memory.
Operation	[m] ← ACC "XOR" [m]
Affected flag(s)	Z

Package Information

Note that the package information provided here is for consultation purposes only. As this information may be updated at regular intervals users are reminded to consult the [Holtek website](#) for the latest version of the [package information](#).

Additional supplementary information with regard to packaging is listed below. Click on the relevant section to be transferred to the relevant website page.

- Further Package Information (include Outline Dimensions, Product Tape and Reel Specifications)
- Packing Materials Information
- Carton information

48-pin LQFP (7mm×7mm) Outline Dimensions

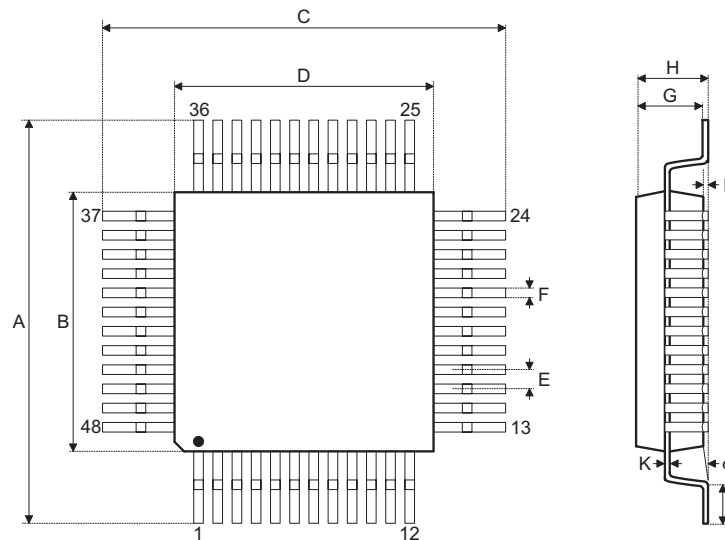

Symbol	Dimensions in inch		
	Min.	Nom.	Max.
A	—	0.354 BSC	—
B	—	0.276 BSC	—
C	—	0.354 BSC	—
D	—	0.276 BSC	—
E	—	0.020 BSC	—
F	0.007	0.009	0.011
G	0.053	0.055	0.057
H	—	—	0.063
I	0.002	—	0.006
J	0.018	0.024	0.030
K	0.004	—	0.008
α	0°	—	7°

Symbol	Dimensions in mm		
	Min.	Nom.	Max.
A	—	9.000 BSC	—
B	—	7.000 BSC	—
C	—	9.000 BSC	—
D	—	7.000 BSC	—
E	—	0.500 BSC	—
F	0.170	0.220	0.270
G	1.350	1.400	1.450
H	—	—	1.600
I	0.050	—	0.150
J	0.450	0.600	0.750
K	0.090	—	0.200
α	0°	—	7°

52-pin LQFP (14mm×14mm) Outline Dimensions

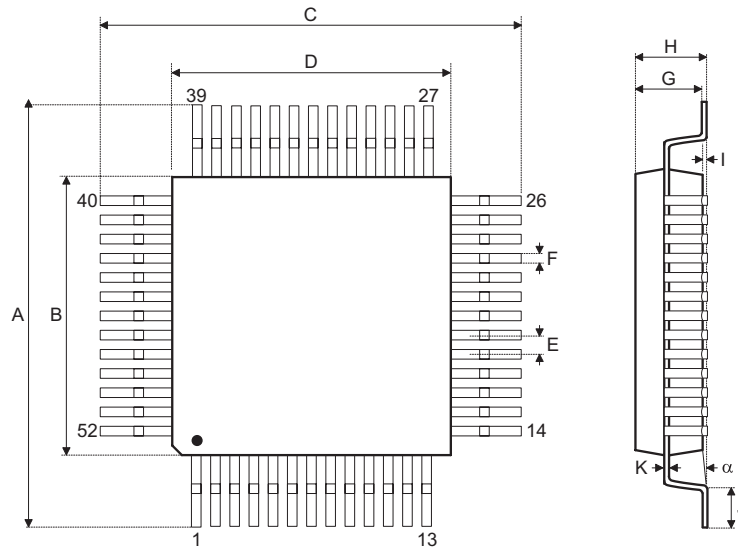

Symbol	Dimensions in inch		
	Min.	Nom.	Max.
A	0.622	0.630	0.638
B	0.547	0.551	0.555
C	0.622	0.630	0.638
D	0.547	0.551	0.555
E	—	0.039 BSC	—
F	0.015	—	0.019
G	0.053	0.055	0.057
H	—	—	0.063
I	0.002	—	0.008
J	0.018	—	0.030
K	0.005	—	0.007
α	0°	—	7°

Symbol	Dimensions in mm		
	Min.	Nom.	Max.
A	15.80	16.00	16.20
B	13.90	14.00	14.10
C	15.80	16.00	16.20
D	13.90	14.00	14.10
E	—	1.00 BSC	—
F	0.39	—	0.48
G	1.35	1.40	1.45
H	—	—	1.60
I	0.05	—	0.20
J	0.45	—	0.75
K	0.13	—	0.18
α	0°	—	7°

Copyright© 2016 by HOLTEK SEMICONDUCTOR INC.

The information appearing in this Data Sheet is believed to be accurate at the time of publication. However, Holtek assumes no responsibility arising from the use of the specifications described. The applications mentioned herein are used solely for the purpose of illustration and Holtek makes no warranty or representation that such applications will be suitable without further modification, nor recommends the use of its products for application that may present a risk to human life due to malfunction or otherwise. Holtek's products are not authorized for use as critical components in life support devices or systems. Holtek reserves the right to alter its products without prior notification. For the most up-to-date information, please visit our web site at <http://www.holtek.com/zh/>.