

3W Ultra Low-EMI Anti-Clipping Stereo Class D Audio Power Amplifier

■ FEATURES

- Anti-Clipping Function (ACF)
- Excellent EMI Suppression Performance
- Optimized PWM Output Stage Eliminating Output Filter
- Maximum Output
 - 3.0 W×2ch ($V_{DD}=5.0V$, $R_L=4\Omega$, THD+N=10%)
 - 1.9 W×2ch ($V_{DD}=5.0V$, $R_L=8\Omega$, THD+N=10%)
- Efficiency
 - 85% @ $V_{DD}=5.0V$, $R_L=4\Omega$, $P_o=1W$
- Low THD+N
 - 0.1% @ $V_{DD}=5.0V$, $R_L=4\Omega$, $P_o=1W$
- Channel separation
 - 80dB @ $f_{IN}=1kHz$, $A_v=18dB$
- High S/N Ratio
 - 90dB @ $V_{DD}=5.0V$, $A_v=18dB$
- Excellent Click-Pop Noise Reduction Function
- MUTE Function
- Independent Channel Power Down Function
- Over-Current Protection Function, Thermal Protection Function
- Low Voltage Malfunction Prevention Function
- Pb-Free Package, TSSOP-20, QFN-20

■ APPLICATIONS

- Portable Speakers, USB Speakers, FM Speakers
- MP3/MP4
- Portable Gamers, Digital Photo Frame
- Mobile Phone, Notebook PC
- Small Size LCD TV/Monitors

■ GENERAL DESCRIPTION

HT6808 is an Ultra Low-EMI Anti-Clipping stereo Class D audio power amplifier IC with maximum output power of 3W, efficiency up to 90%.

HT6808 features Anti-Clipping Function (ACF) which detects output signal clip due to the over input signal and suppresses the output signal clip automatically. Also the ACF function can adapt the output clip caused by power supply voltage down with battery. It can significantly improve the sound quality, creating a very comfortable musical enjoyment, and to protect the speakers from overload damage. In addition Sound quality and output power can be freely set by external resistance or capacitance of ACRC. HT6808 also supply ACF OFF mode.

HT6808 has excellent EMI radiation suppression characteristics, well below the FCC Part15 Class B standards, simplifying system design and lowering system cost.

HT6808 has a "Pure Pulse Direct Speaker Drive Circuit" which directly drives speakers while reducing distortion of pulse output signal and reducing noise on the signal, and realizes the highest standard low distortion rate characteristics and low noise characteristics among digital amplifier ICs for portable use.

HT6808 has the independent Shutdown function which can minimize the power consumption at standby and MUTE function. As for protection function, over current protection function for speaker output terminals, over temperature protection function, and low supply voltage malfunction preventing function are also prepared.

HT6808 is available in Pb-Free TSSOP-20 and QFN-20 package.

■ TYPICAL APPLICATION

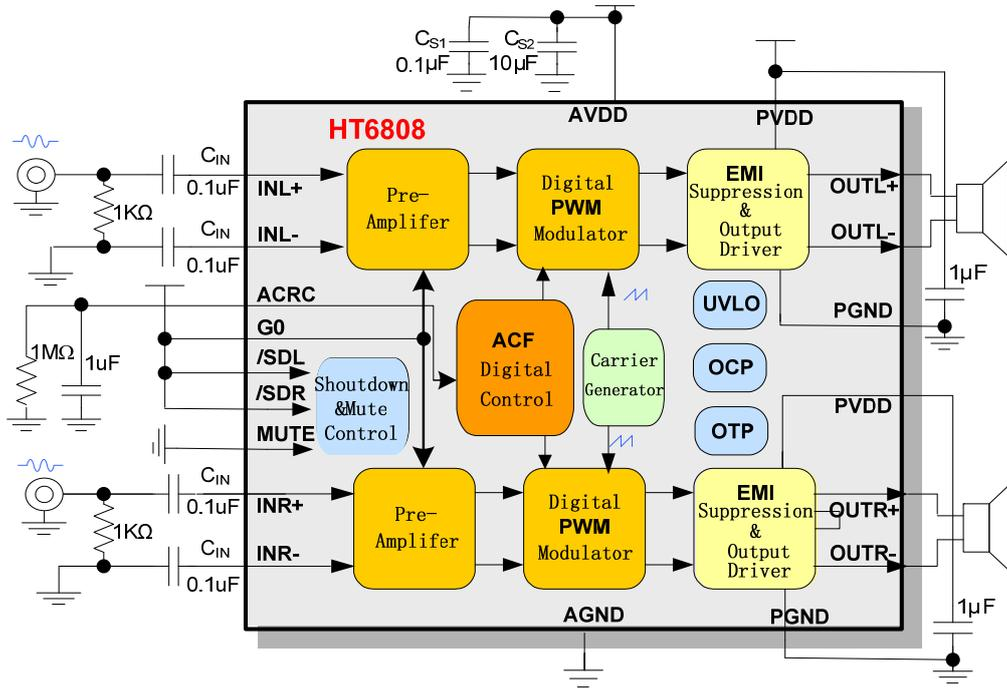

■ **TERMINAL CONFIGURATION**

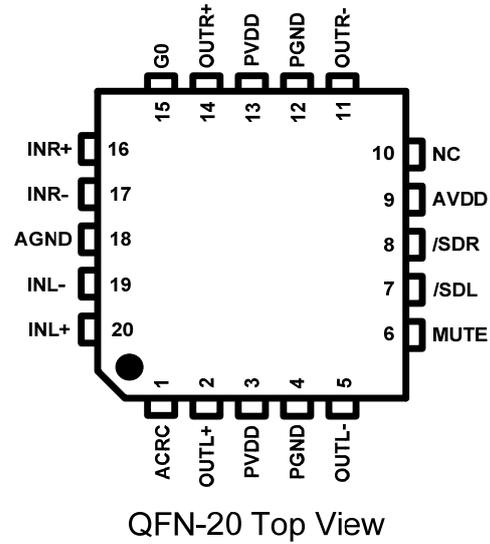
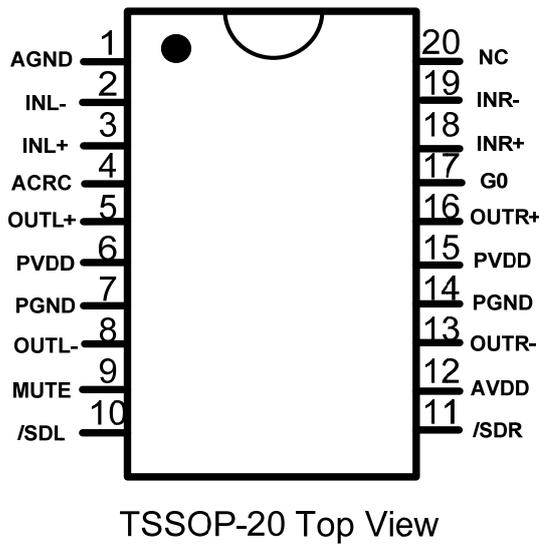

■ **TERMINAL FUNCTION** *1

Terminal No.		Name	I/O	Function
TSSOP20	QFN20			
1	18	AGND	GND	GND for analog circuits
2	19	INL-	A	Negative input terminal (differential -) Lch
3	20	INL+	A	Positive input terminal (differential +) Lch
4	1	ACRC	I/O	Anti-clipping control terminal
5	2	OUTL+	O	Positive output terminal (differential +) Lch
6	3	PVDD	Power	Power supply for output
7	4	PGND	GND	GND for output
8	5	OUTL-	O	Negative output terminal (differential -) Lch
9	6	MUTE	I	Mute control terminal
10	7	/SDL	I	Shut-down terminal for Lch
11	8	/SDR	I	Shut-down terminal for Rch
12	9	AVDD	Power	Power supply for analog circuits
13	11	OUTR-	O	Negative output terminal (differential -) Rch
14	12	PGND	GND	GND for output
15	13	PVDD	Power	Power supply for output
16	14	OUTR+	O	Positive output terminal (differential +) Rch
17	15	GO	I	Gain setting terminal
18	16	INR+	A	Positive input terminal (differential +) Rch
19	17	INR-	A	Negative input terminal (differential -) Rch
20	10	NC	—	Non connection

*1 I: Input terminal O: Output terminal A: Analog terminal

■ BLOCK SCHEME

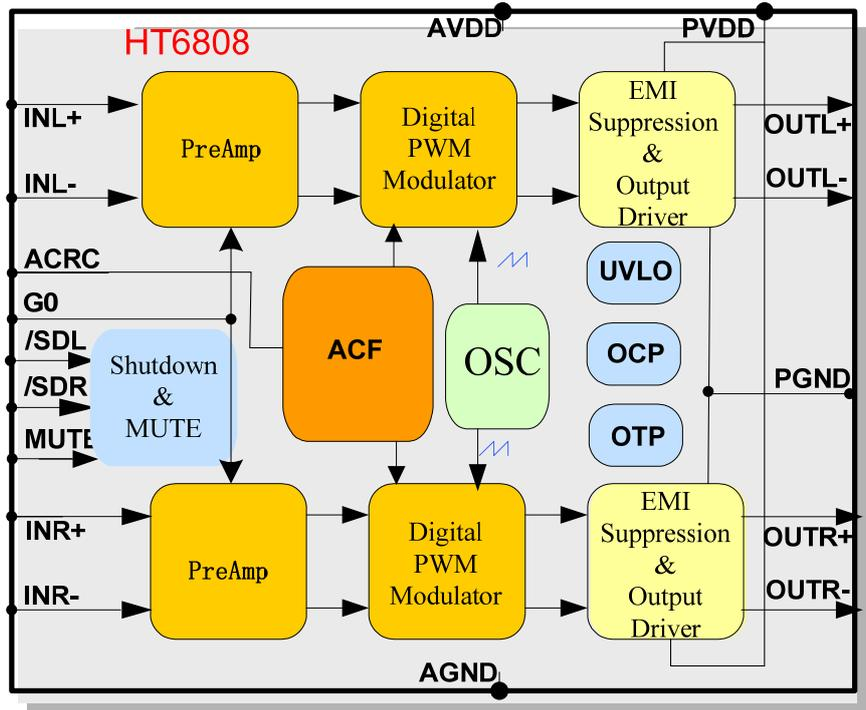

■ Electrical Characteristic

● Absolute Maximum Ratings*1

Item	Symbol	Min.	Max.	Unit
Power supply terminal voltage range	V _{DDP}	-0.3	6.0	V
Analog supply terminal voltage range	V _{DDA}	-0.3	6.0	V
Input terminal voltage range (Analog input terminal: IN+, IN-)	V _{IN}	V _{SS} -0.6	V _{DD} +0.6	V
Input terminal voltage range (Input terminals except IN+, IN-)	V _{IN}	V _{SS} -0.3	V _{DD} +0.3	V
Junction Temperature	T _{JMAX}		125	°C
Storage Temperature	T _{STG}	-50	125	°C

*1: Absolute Maximum Ratings is values which must not be exceeded to guarantee device reliability.

● Recommended Operating Condition

Item	Symbol	Min.	Typ.	Max.	Unit
Power Supply Voltage	V _{DD}	2.7	3.6	5.5	V
Analog Supply Voltage	V _{DDA}	2.7	3.6	5.5	V
Operating Ambient Temperature	T _a	-40	25	85	°C

● DC Characteristics

V_{SS}=0V, V_{DD}=2.7V to 5.5V, T_a= -40°C to 85°C, unless otherwise specified.

Item	Symbol	Conditions	Min.	Typ.	Max.	Unit
AVDD power supply start-up threshold voltage	V _{UVLH}			2.2		V
AVDD power supply shut-down threshold voltage	V _{UVLL}			2.0		V
/SDL,/SDR,MUTE,G0 H level input voltage	V _{IH}		1.35			
/SDL,/SDR,MUTE,G0 L level input voltage	V _{IL}				0.35	V
AVDD consumption current	I _{AVDD}	V _{DDA} =5V, no load		6.0		mA
PVDD consumption current	I _{PVDD}	V _{DD} =5V, no load, no signal input		2.0		mA
consumption current in Mute mode	I _{MUTE}	V _{MUTE} =V _{DDA} =V _{DDP} =5V		6		mA
consumption current in Shutdown mode (AVDD+PVDD)	I _{PD}	/SDL= /SDR=V _{SS} , T _a =25°C		0.01		μA

● AC Characteristics

V_{SS}=0V, V_{DDA}=V_{DDP}=2.7 to 5.5V, T_a=-40°C to 85°C, unless otherwise specified.

Item	Symbol	Conditions	Min.	Typ.	Max.	Unit
Start-up time	t _{STUP}			32		ms
Input cut-off frequency	f _c	C _{IN} =0.1uF, A _v =18dB		36		Hz
Attack time	t _{AT}	V _{DDA} =5V, C _{ex} =1uF, R _{ex} =1MΩ		25		ms
Release time	t _{RL}	V _{DDA} =5V, C _{ex} =1uF, R _{ex} =1MΩ		0.25		ms
Carrier clock frequency	f _{PWM}			250		KHz

● **Analog Characteristics**^{*1}

$V_{SS}=0V$, $V_{DDA}=V_{DDP}=5V$, $R_L=4\Omega$, $T_a=25^\circ C$, ACF Off, unless otherwise specified.

Item	Symbol	Conditions	Min.	Typ.	Max.	Unit
Output Power	P_o	$R_L=4\Omega$		3		W
		$R_L=8\Omega$		1.9		W
Voltage Gain	A_v	G0=L		18		dB
		G0=H		24		
Total Harmonic Distortion plus Noise (BW: 20kHz)	THD+N	$R_L=4\Omega$, $P_o=1W$, $f=1kHz$		0.1		%
		$R_L=8\Omega$, $P_o=0.5W$, $f=1kHz$		0.15		%
Signal /Noise Ratio (BW: 20kHz A-Filter)	SNR	$A_v=18dB$		90		dB
Channel Separation Ratio	CS	1kHz, $A_v=18dB$		80		dB
Power supply rejection ratio	PSRR	$f=1kHz$, 200mVp-p		-50		dB
Efficiency	η	$R_L=4\Omega$, $P_o=1W$		85		%
		$R_L=8\Omega$, $P_o=0.5W$		85		%
Output offset voltage	V_{os}			± 5		mV
Frequency characteristics	f_{RES}	$C_{IN}=0.1\mu F$, , $A_v=18dB$, $f=100Hz$ to 20 kHz	-4	-	0.4	dB
ACF maximum attenuation gain	$A_{a_{max}}$			-10		dB

*1: All the values of analog characteristics were obtained by using our evaluation circumstance;

Depending upon parts and pattern layout to use, characteristics may be changed.

■ APPLICATION INFORMATION

● Operating Mode

HT6808 provides several kinds of operating mode as following (to see Table 1): The typical mode, the ACF mode, the shutdown mode and the mute mode.

Table 1. the working mode

/SDR & /SDL	MUTE	ACRC ^{*1}	Working mode
H	L or Floating	L or H	Typical mode
H	L or Floating	Terminal R _{ex} 、C _{ex} ^{*2}	ACF mode
L	—	—	Shutdown mode
H	H	—	Mute mode

*1: Floating ACRC pin is not allowed;

*2: the connection circuit is shown in Fig. 5.

Note: L and H refer to logic low and logic high.

Typical Mode

In the Typical Mode, HT6808 amplifies the signal with a gain that's already set.

ACF Mode

In this mode, HT6808 can adapt the amplitude of the input signal or the reduction of power supply to realize an output without clipping, which can improve the sound quality, create a very comfortable musical enjoyment and protect the speakers from overload damage.

Shut-down Mode

This is the function to turn Rch into the power-down mode when setting /SDR terminal to a logic Low level and to turn Lch into the power-down mode when setting /SDL terminal to a logic Low level. The power-down mode stops all the functions and minimizes current consumption. At this time, the differential output signal becomes Weak Low state (a state grounded through high resistivity).

HT6808 will start up within the start-up time (T_{stup}) when setting /SDR and /SDL terminals to a logic High state.

Mute Mode^{*3}

This is the function to turn the chip into the mute mode when setting MUTE terminal to a logic High level. At this time, the differential output signal becomes Weak Low state (a state grounded through high resistivity). Once the mute terminal is set from logic high to logic low level, HT6808 can return to the normal working state (the typical mode or ACF mode) immediately. When MUTE terminal is floating, the mute mode will not be triggered.

*3: With a lower priority than the shut-down mode, the mute mode can make the system rapidly turn on/off without a setup time T_{STUP}, and no pop noise occurs.

● Gain setting

G0 terminal can set the Gain of HT6808. When ACF function is disabled, the relation between G0 terminal setting and Gain is as follows. (shown in table 2.)

Table 2. Gain Setting

G0	Gain(dB)	Rin(kΩ)
L	18	44
H	24	28

Note: L and H refer to logic low and logic high.

● **Analog Signal Input Configuration**

Input Lch differential input signals to INL+ terminal and INL- terminal through DC-cut capacitors (C_{IN}),

For single ended operation, input the signal to INL+ pin through the DC-cut capacitor (C_{IN}). At this time, INL- pin must be connected to AVSS pin through a capacitor (C_{REF} : same value as C_{IN}), which is shown in Fig.2. As with Lch, connect input signals to Rch.

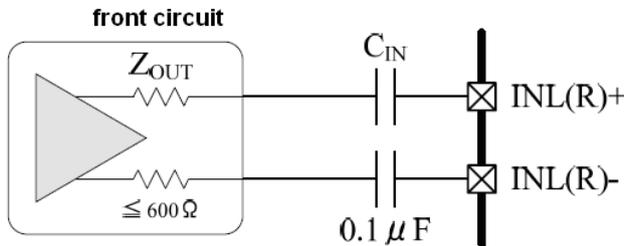

Fig.1 Differential Input

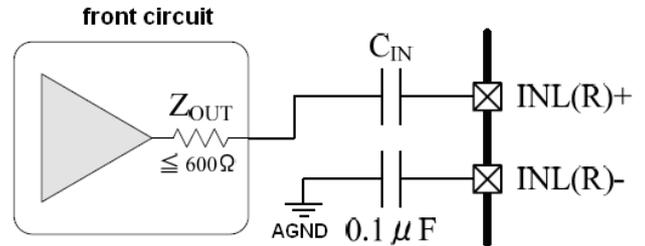

Fig.2 Single-ended Input

In addition, positive (+) and negative (-) sides of differential input pins (INL+ and INL-, or INR+ and INR-), input pins of the unused channel side, should be connected to each other and connected to AVSS through a capacitor, shown as Fig.3.

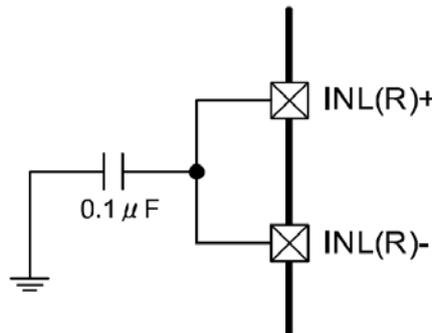

Fig. 3 Input terminal processing of unused channel side

The lower cut-off frequency (f_c) can be found from DC-cut capacitor (C_{IN}) and input impedance (Z_{IN}) as shown below.

$$f_c = 1/(2 * \pi * Z_{IN} * C_{IN}), Z_{IN} \text{ is the input impedance of the amplifier.}$$

In order to reduce pop-noise, impedance in the differential input signal source is arranged. And, DC-cut capacitor (C_{IN}) should be 0.1μF or less.

● **Anti-clipping Function**

When the amplitude of the input signal is over-high, or the power supply voltage is reduced, a clip distortion will come into being and the annoying noise can possibly be appeared without ACF function. The ACF function can adapt the amplitude of the input signal or the reduction of power supply, and adjust the Gain of the digital amplifier to an appropriate value so as not to cause the clipping at the differential signal output, which can improve the sound quality, create a very comfortable musical enjoyment, and protect the speakers from overload damage.

The principle of the ACF function is shown as Fig.4.

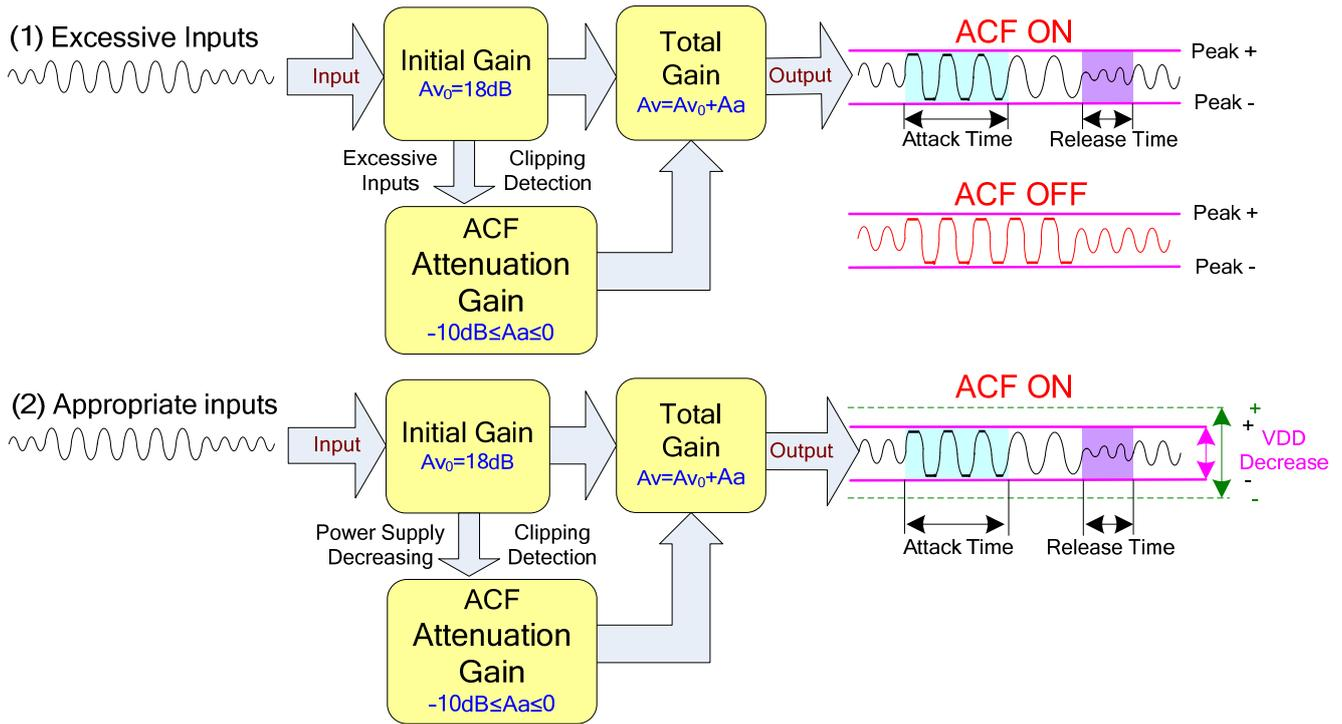

Fig.4 Operation outline of the ACF Function

Connecting a resistor (R_{ex}) and a capacitor (C_{ex}) to ACRC terminal can set Attack Time^{*1} and Release Time^{*2} of the Anti-clipping control, which is shown as Fig.5.

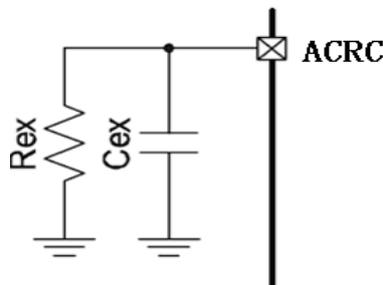

Fig 5. ACF Terminal Control Circuit

*1.The attack time: the time interval until the system gain falls to target attenuation gain -3dB with a big signal input enough.

*2.The release time: the time interval from target attenuation gain (A_a) to not working of ACF.

● Protection Function

HT6808 has the following protection functions for the digital amplifier: Over-current Protection function, Thermal Protection function, and Low voltage Malfunction Prevention function.

Over-current Protection function

This is the function to establish the over-current protection mode when detecting a short circuit between HT6808 differential output pin and V_{SS} , V_{DD} , or another differential output. The function works independently for Lch and Rch. In the over current protection mode, the differential output pin becomes a high impedance state.

Setting /SDR pin to a logic Low state can cancel the Rch over current protection mode. Likewise, when setting /SDL pin to a logic Low level, the over current protection mode applied to Lch can be cancelled. In addition, turning on the power again can cancel the over current protection mode applied to Lch and Rch.

Thermal Protection function

This is the function to establish the thermal protection mode when detecting excessive high temperature of HT6808 itself. In the thermal protection mode, the differential output pin becomes Weak Low state (a state grounded through high resistivity). And, when HT6808 gets out of such condition, the protection mode is cancelled.

Low Voltage Malfunction Prevention function

This is the function to establish the low voltage protection mode when AVDD terminal voltage becomes lower than the detection voltage (VUVLL) for the low voltage malfunction prevention. And the protection mode is canceled when AVDD terminal voltage becomes higher than the threshold voltage (VUVLH). In the low voltage protection mode, the differential output pin becomes Weak Low state (a state grounded through high resistivity). HT6808 will start up within the start-up time (TSTUP) when the low voltage protection mode is cancelled.

● Pop-Click Noise Reduction

The Pop-Click Noise Reduction Function works in the cases of Power-on, Power-off, Shutdown on, and Shutdown off. And the pop-noise can be suppressed according to control the power down by the following procedure.

- /SDR and /SDL terminal are assumed to be H, after power-on.
- /SDR and /SDL terminal are assumed to be L, before Power-off.

■ Application Circuit Examples

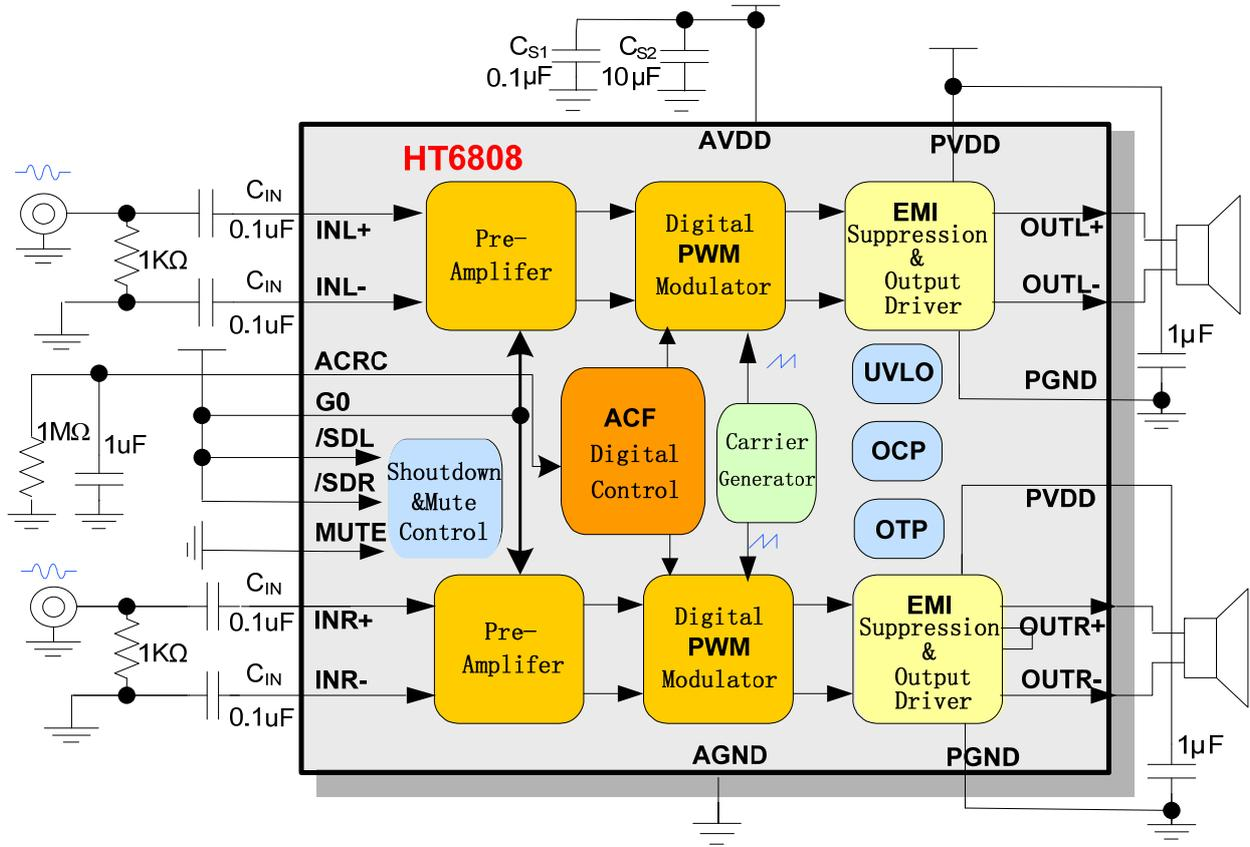

■ PACKAGE OUTLINE

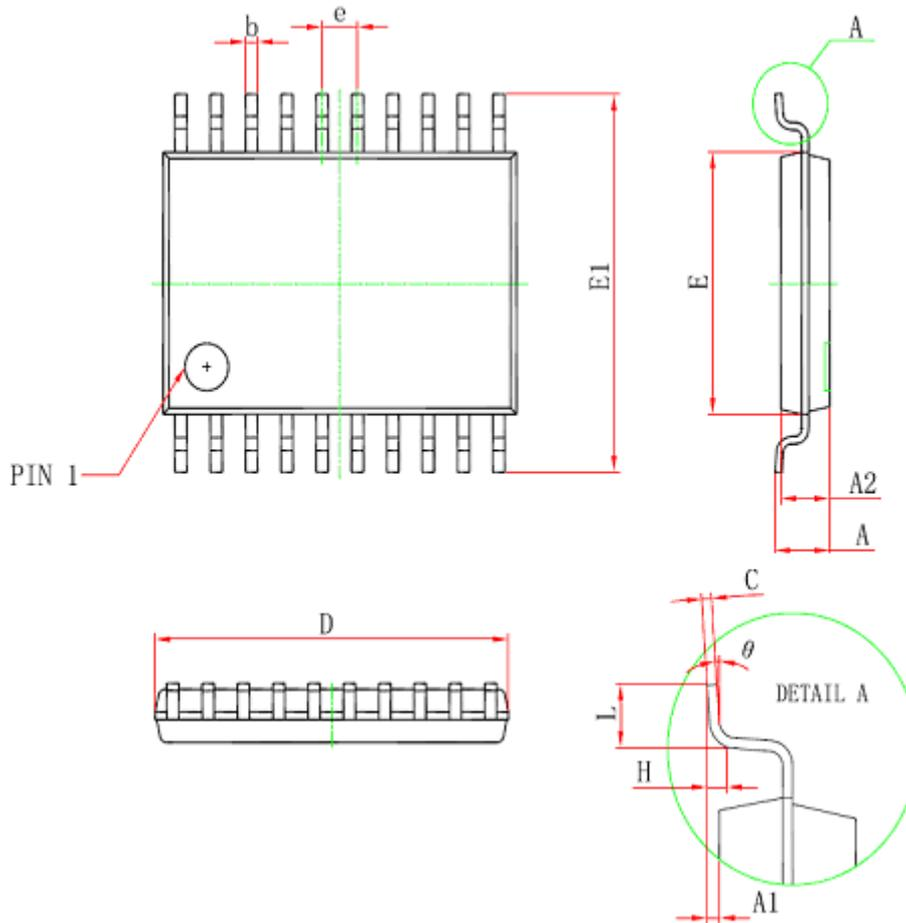
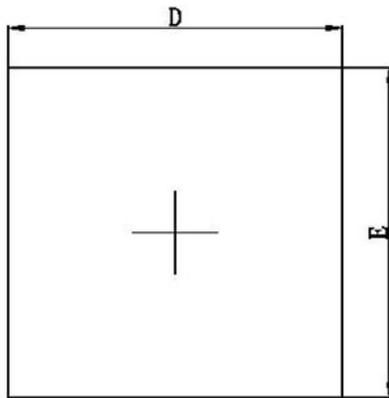

Table 3. TSSOP20 Package standard

Symbol	Size (mm)		Size (inch)	
	MIN	MAX	MIN	MAX
D	6.400	6.600	0.252	0.259
E	4.300	4.500	0.169	0.177
b	0.190	0.300	0.007	0.012
c	0.090	0.200	0.004	0.008
E1	6.250	6.550	0.246	0.258
A		1.100		0.043
A2	0.800	1.000	0.031	0.039
A1	0.020	0.150	0.001	0.006
e	0.65(BSC)		0.026(BSC)	
L	0.500	0.700	0.02	0.028
H	0.25(TYP)		0.01(TYP)	
θ	1°	7°	1°	7°

● QFN20



Top View

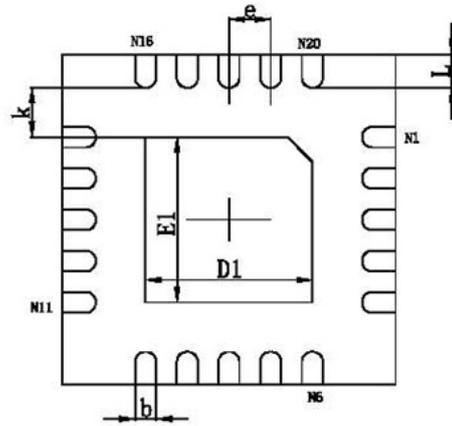

Bottom View

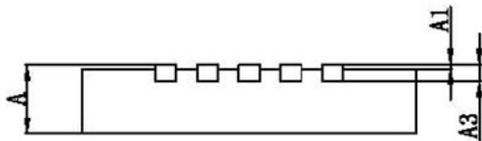

Side View

Table 4. QFN20 Package Standard

Symbol	Size (mm)		Size (inch)	
	MIN	MAX	MIN	MAX
A	0.700/0.800	0.800/0.900	0.028/0.031	0.031/0.035
A1	0.000	0.050	0.000	0.002
A3	0.203REF		0.008REF	
D	3.900	4.100	0.154	0.161
E	3.900	4.100	0.154	0.161
D1	1.900	2.100	0.075	0.083
E1	1.900	2.100	0.075	0.083
k	0.200MIN		0.008MIN	
b	0.180	0.300	0.007	0.012
e	0.500(TYP)		0.020(TYP)	
L	0.300	0.500	0.012	0.020

Jiaxing Heroic Technology Corporation, Limited

Add: A 3rd floor, JRC Building, Yatai Road, Jiaxing, Zhejiang Province

Tel: 0573-82583866 82585565

Fax: 0573-82585078

E-mail: sales@heroic.com.cn

Web: www.heroic.com.cn

HT6808 QFN20 产品封装规范

■ 封装信息

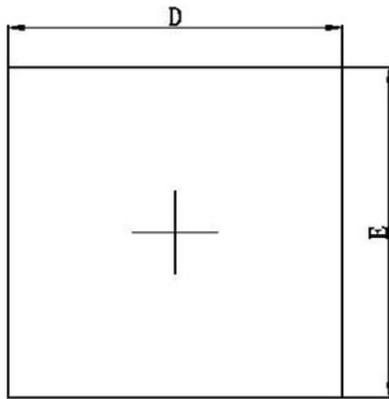

Top View

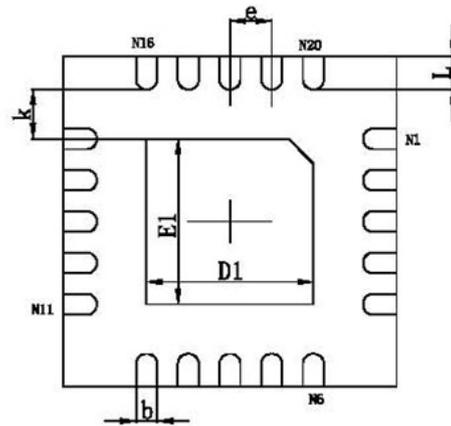

Bottom View

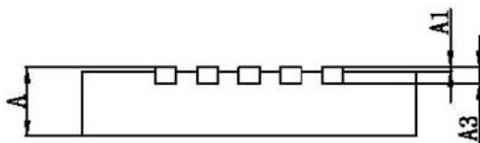

Side View

符号	尺寸 (mm)		尺寸 (inch)	
	最小	最大	最小	最大
A	0.700/0.800	0.800/0.900	0.028/0.031	0.031/0.035
A1	0.000	0.050	0.000	0.002
A3	0.203REF		0.008REF	
D	3.900	4.100	0.154	0.161
E	3.900	4.100	0.154	0.161
D1	1.900	2.100	0.075	0.083
E1	1.900	2.100	0.075	0.083
k	0.200MIN		0.008MIN	
b	0.180	0.300	0.007	0.012
e	0.500(TYP)		0.020(TYP)	
L	0.300	0.500	0.012	0.020

■ 包装流程图及包装规范



封装 PKG	载带/盖带 tape	卷盘 Reel	包装箱 Box	只/盘 pcs/reel	盘/盒 reel/box	只/盒 pcs/box	盒/箱 box/carton	只/箱 pcs/carton
QFN4*4*0.75/0.85	IC-ZD-12	13" (IC-JP-01)	IC14#	5000	1	5000	8	40000

■ 订购信息

产品型号	封装形式	顶面标记	工作温度范围 (扩展工业级)	包装和供货形式
HT6808SQ	QFNWB4*4-20L	HT6808SQ XYMLLA	-40℃~85℃	卷带装 5000颗/盘

H T 6 8 0 8 S Q
X Y M L L A

- 编号定义：1、HT6808 代表芯片名称；
2、SQ 代表芯片封装形式：QFN 封装；
3、X：芯片材质； Y：版本号； M：月份编码，1-9 及 J、Q、K；
LL：生产批次； A：随机编码，一个月内按 A-Z 按批顺编；

嘉兴禾润电子科技有限公司

地址：浙江省嘉兴市凌公塘路 3339 号 JRC 大厦 A 座三层

电话：0573-82583866 82585565

传真：0573-82585078

E-mail: sales@heroic.com.cn

网址：www.heroic.com.cn