

HT6P20B2/D2/F2

Remote Control Encoder



Features

- Operating voltage: 2~12V
- Low power consumption
- Up to 5 data pins
- Up to 2²² address codes
- Fully Integrated Oscillator
- Easy interfacing to RF medium
- CMOS technology
- High noise immunity
- 8-Pin SOP package

Application

- Burglar alarm systems
- Smoke and fire alarm systems
- Personal alarm systems
- Car/Garage door controllers
- Home/office/car security systems
- Cordless telephones
- Other remote control systems

General Description

The HT6P20X2 series of devices are signal encoders designed for remote control system applications. The devices are capable of encoding 24 bits of information and then serially transmitting the data on their output pin. A signal transmission is automatically activated when any of the data input lines change from high to low. The device generates a signal on its output pin which is composed of a pilot signal, address codes, data codes and an end code. This can be sent to RF transmitter circuits for wireless transmission. Various configurations of address and data bits can be chosen according to which device is selected. As all functions are integrated into the device, the simple addition of switches and RF module is that is required to implement a full RF encoder function. All devices are supplied in 8-pin SOP packages.

Selection Table

The devices encodes 24-bits of information however the address/data combination is selected according to which part number is selected.

Part Number	Address	Data
HT6P20B2	22	2
HT6P20D2	20	4
HT6P20F2	19	5

Block Diagram

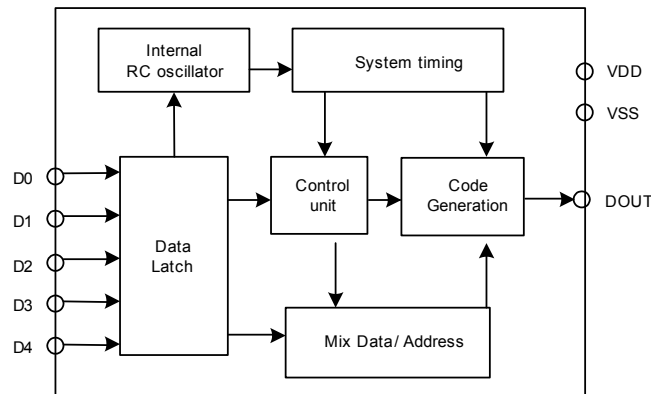

Note: Address and Data combinations are available in various formats.

Pin Assignment

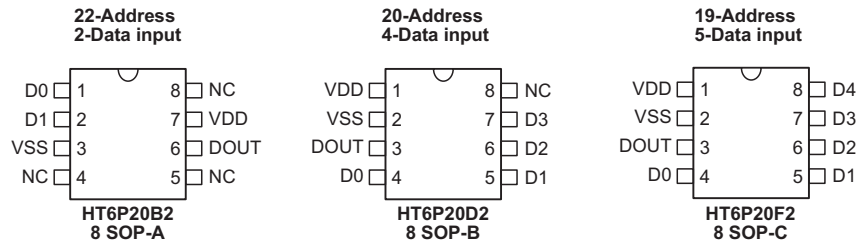

Pin Description

Pin Name	Type	Description
VDD	—	Positive power supply
VSS	—	Negative power supply
D0~D4	I	Data input and transmission enable - active low Connected to internal pull-high resistor Pins can be pulled low or left open
DOUT	O	Data serial transmission output pin Output normally low when not transmitting

Approximate Internal Equivalent Circuits

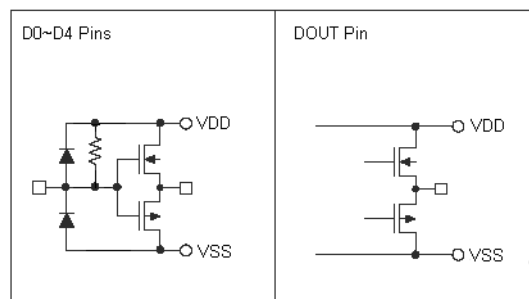

HT6P20B2/D2/F2

Remote Control Encoder



Absolute Maximum Ratings

Supply Voltage	$V_{SS}-0.3V$ to $V_{SS}+15V$
Input Voltage	$V_{SS}-0.3V$ to $V_{DD}+0.3V$
Output Voltage.....	$V_{SS}-0.3V$ to $V_{DD}+0.3V$
Storage Temperature	$-55^{\circ}C$ to $150^{\circ}C$
Operating Temperature	$-40^{\circ}C$ to $85^{\circ}C$

Note: These are stress ratings only. Stresses exceeding the range specified under “Absolute Maximum Ratings” may cause substantial damage to the device. Functional operation of this device at other conditions beyond those listed in the specification is not implied and prolonged exposure to extreme conditions may affect device reliability.

D.C. Characteristics

$T_a=25^{\circ}C$

Symbol	Parameter	Test Conditions		Min.	Typ.	Max.	Unit
		V_{DD}	Conditions				
V_{DD}	Supply Voltage	—	—	2	—	12	V
I_{SB}	Stand-by current	12	No load Input pins floating	—	—	1.0	μA
I_{OP}	Operating current	5	No load Single data input pin “low”	—	30	100	μA
		12		—	300	500	
V_{IH}	“H” Input Voltage	—	—	$0.8V_{DD}$	—	—	V
V_{IL}	“L” Input Voltage	—	—	—	—	$0.2V_{DD}$	V
R_{PH}	Pull-high Resistor	5	D0~D4	—	400	800	K Ω
		12		—	150	300	
I_{OH}	Hi-level output current	5	$V_{OH}=0.9V_{DD}$; DOUT	-2	-2.5	—	mA
		12		-6.5	-15	—	
I_{OL}	Low-level output current	5	$V_{OL}=0.1V_{DD}$; DOUT	2	2.5	—	mA
		12		6.5	15	—	
t_{DW}	Single bit data width	5	—	1.08	1.2	1.32	ms

Note: Single bit data width (t_{DW}) vs. V_{DD} curve is shown as below:

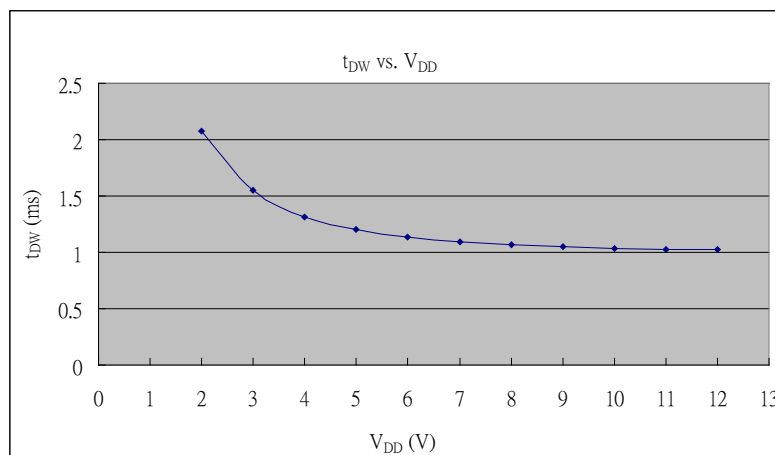

Functional Description

The HT6P20X2 series of remote control devices provide a means for easy remote control signal encoding. As all functions, including the system oscillator, are integrated within the devices, the addition of external switches and an RF transmitter is all that is required to implement a full remote control transmitter function.

The devices will generate an encoded signal on their output pin, DOUT, composed of pilot code, address code, data code and end code. The signal is automatically generated on the DOUT pin when any of the data input pins, D0~D4, change from high to low. Internal pull-high resistors keep these data input pins in a normally high condition. The output signal can be interfaced to RF modules for wireless signal transmission.

Signal Generation

The devices will encode and transmit pilot code, address/data and end code, upon receipt of a trigger signal. The trigger signal is a high to low transition on any of the data input pins, D0~D4. The pins are normally kept at a high level by internal pull-high resistors.

Code Word

What is known in this datasheet as a code word is a packet of information composed of pilot code, address code, data code and end code. The pilot code and end code is the same for all devices. The address and data combinations are shown in the following signal descriptions.

HT6P20B2

Pilot code	A0~A21	D1~D0	End code (0101)
------------	--------	-------	-----------------

HT6P20D2

Pilot code	A0~A19	D3~D0	End code (0101)
------------	--------	-------	-----------------

HT6P20F2

Pilot code	A0~A18	D4~D0	End code (0101)
------------	--------	-------	-----------------

The following shows a complete code word transmission signal. Note that if the Data lines remain low then the signal will be continuously transmitted.

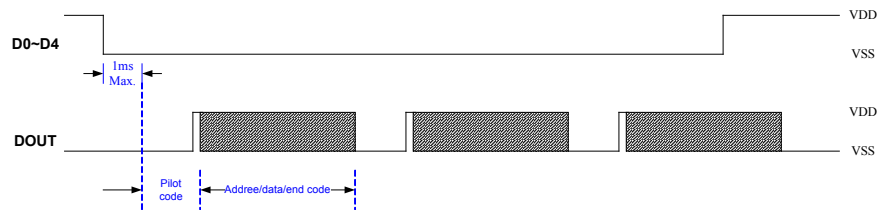

Signal Trigger

Signal transmission is initiated when any of the data input pins change from high to low. Note that the duration of the data input low signals must be greater than the pilot code length for a full signal transmission to occur. If the input low signal is less than the pilot code length then only the pilot code signal will be transmitted and no address, data or end code will be transmitted.

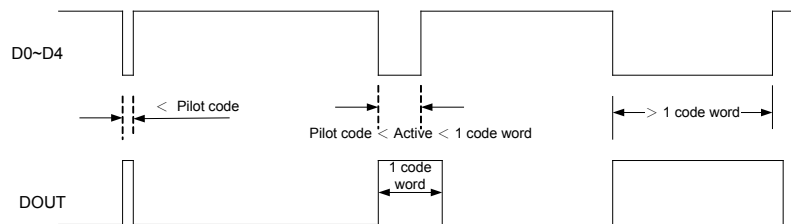

HT6P20B2/D2/F2

Remote Control Encoder



Pilot Code

Each transmission has a pilot code preceding the address and data codes. This is to alert the decoder that address and data bits are about to be transmitted. The pilot code waveform is composed of a low pulse of 23λ duration followed by a high pulse of 1λ duration. Note that a 1λ time unit is equal to 32 internal oscillator time periods.

The pilot code is initiated when any of the data input pins change from high to low. Note that the duration of the data input low signals must be greater than the pilot code length for a full signal transmission to occur. If the input low signal is less than the pilot code length then only the pilot code signal will be transmitted and no address, data or end code will be transmitted.

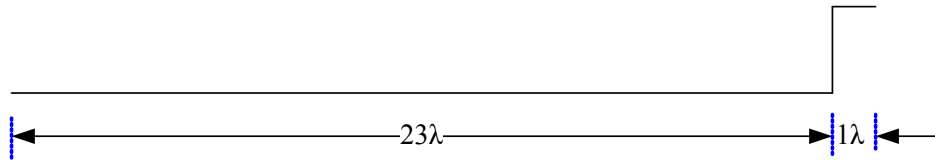

Address/Data Bit Waveform

As address/data bits can be designated as either "0" or "1" they must be encoded in a certain way. One bit consists of one pulse cycle and each pulse cycle has a duration of 96 internal oscillator periods.

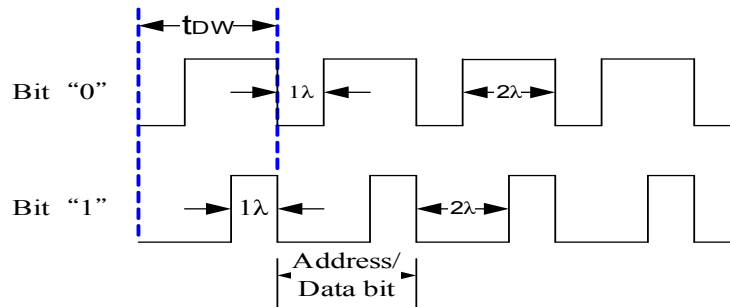

- Note:
- $1\lambda = 32$ internal oscillator time periods.
 - Bit "0" consists of a "low" pulse for 1λ then a "high" pulse for 2λ .
 - Bit "1" consists of a "low" pulse for 2λ then a "high" pulse for 1λ .

End code Waveform

The end code is located after the address/data and consists of 4 bits of data with the bit pattern 0101 as shown below

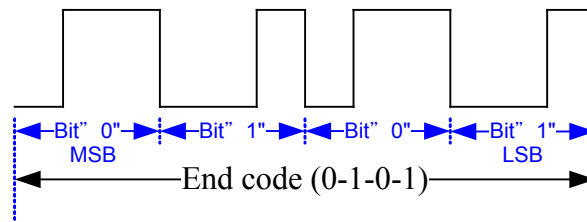

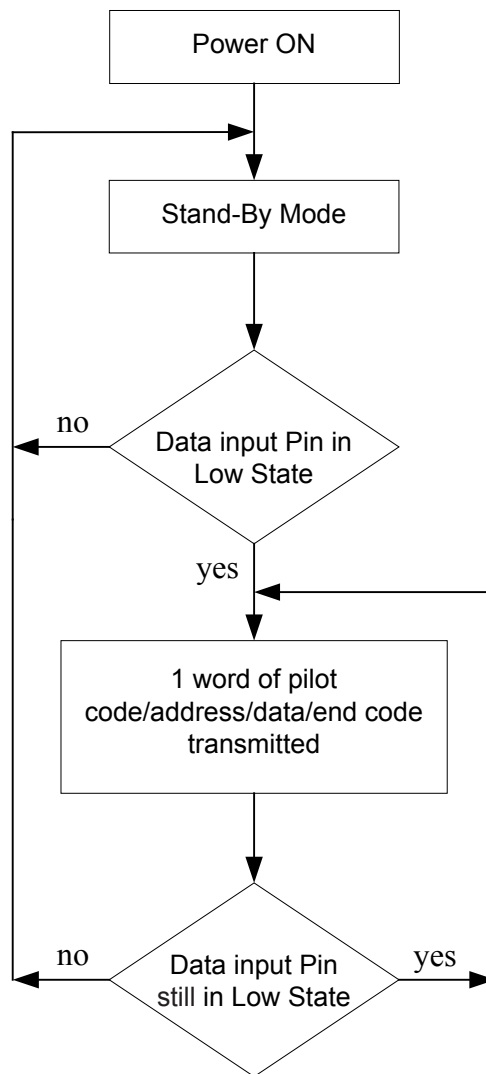
Operation Flowchart

HT6P20B2/D2/F2 Remote Control Encoder



Application Circuit

HT6P20B2

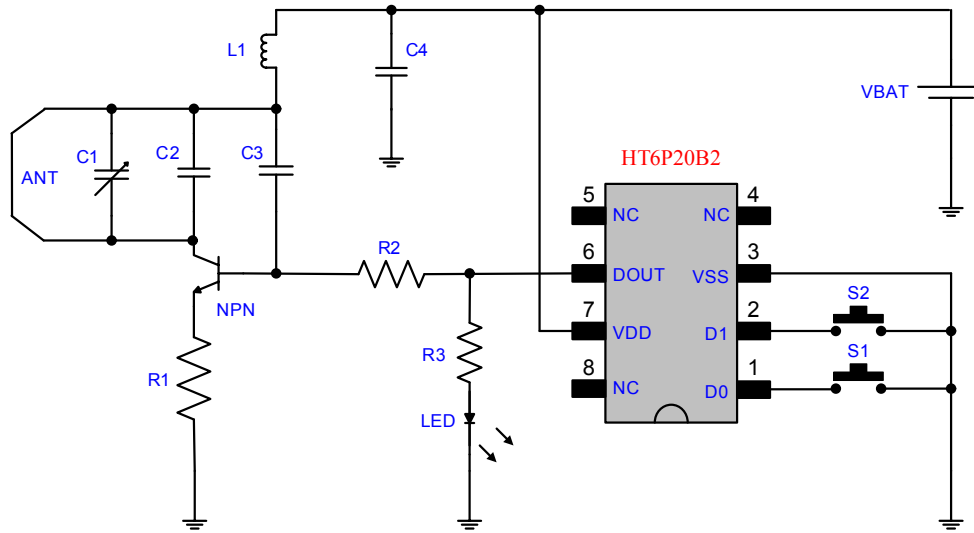

HT6P20D2

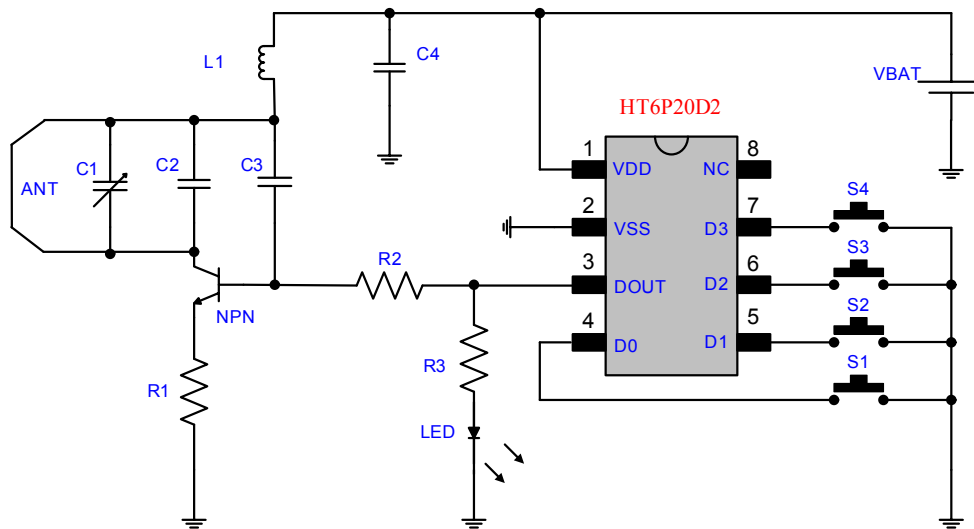

HT6P20F2

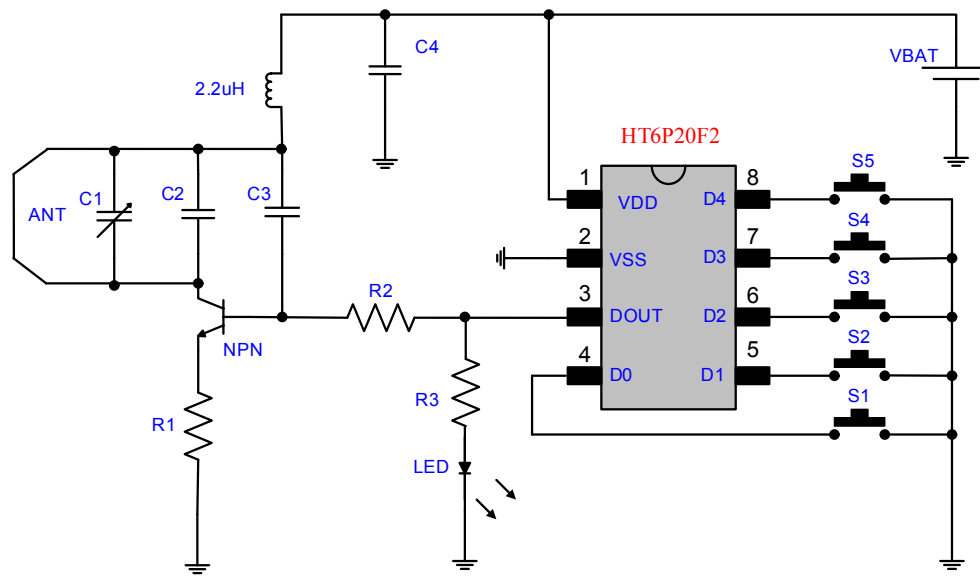

HT6P20B2/D2/F2

Remote Control Encoder



Package Information

8-pin SOP (150mil) Outline Dimensions

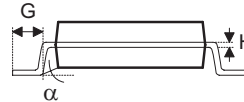
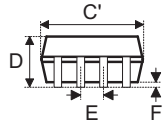
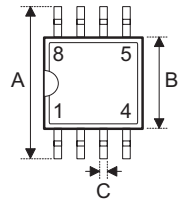

- MS-012

Symbol	Dimensions in inch		
	Min.	Nom.	Max.
A	0.228	—	0.244
B	0.150	—	0.157
C	0.012	—	0.020
C'	0.188	—	0.197
D	—	—	0.069
E	—	0.050	—
F	0.004	—	0.010
G	0.016	—	0.050
H	0.007	—	0.010
α	0°	—	8°

Symbol	Dimensions in mm		
	Min.	Nom.	Max.
A	5.79	—	6.20
B	3.81	—	3.99
C	0.30	—	0.51
C'	4.78	—	5.00
D	—	—	1.75
E	—	1.27	—
F	0.10	—	0.25
G	0.41	—	1.27
H	0.18	—	0.25
α	0°	—	8°

Reel Dimensions

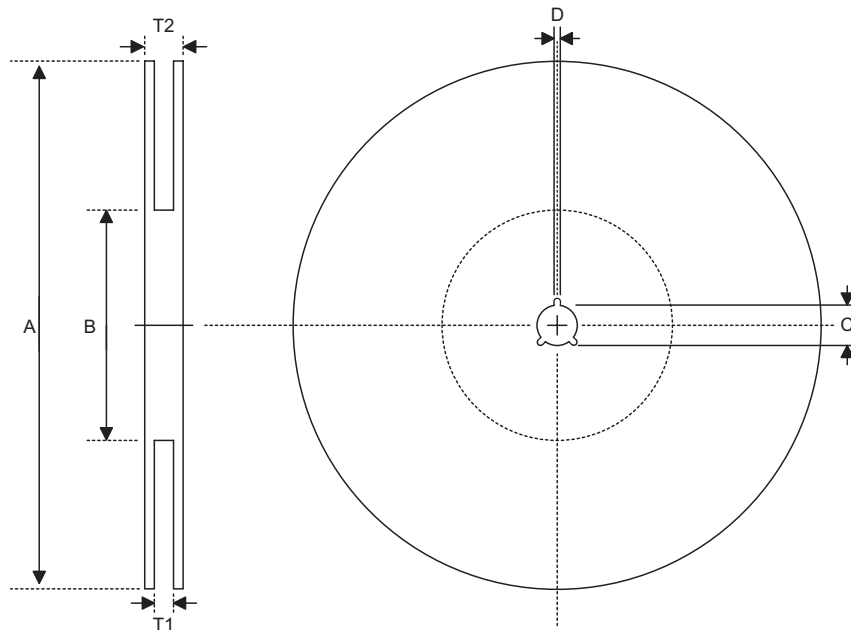

- SOP 8N

Symbol	Description	Dimensions in mm
A	Reel Outer Diameter	330.0±1.0
B	Reel Inner Diameter	100.0±1.5
C	Spindle Hole Diameter	13.0 ^{+0.5/-0.2}
D	Key Slit Width	2.0±0.5
T1	Space Between Flange	12.8 ^{+0.3/-0.2}
T2	Reel Thickness	18.2±0.2

HT6P20B2/D2/F2 Remote Control Encoder



Carrier Tape Dimensions

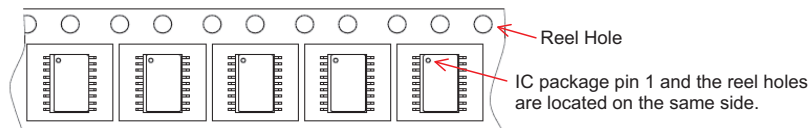
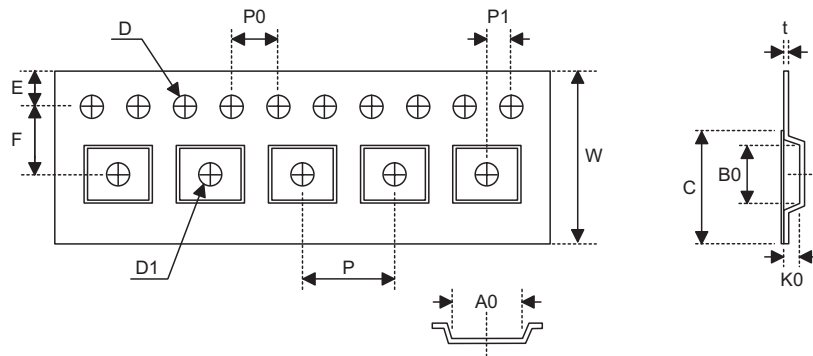

• SOP 8N

Symbol	Description	Dimensions in mm
W	Carrier Tape Width	12.0 ^{+0.3/-0.1}
P	Cavity Pitch	8.0±0.1
E	Perforation Position	1.75±0.1
F	Cavity to Perforation (Width Direction)	5.5±0.1
D	Perforation Diameter	1.55±0.1
D1	Cavity Hole Diameter	1.50 ^{+0.25/-0.00}
P0	Perforation Pitch	4.0±0.1
P1	Cavity to Perforation (Length Direction)	2.0±0.1
A0	Cavity Length	6.4±0.1
B0	Cavity Width	5.2±0.1
K0	Cavity Depth	2.1±0.1
t	Carrier Tape Thickness	0.30±0.05
C	Cover Tape Width	9.3±0.1

Holtek Semiconductor Inc. (Headquarters)

No.3, Creation Rd. II, Science Park, Hsinchu, Taiwan
Tel: 886-3-563-1999
Fax: 886-3-563-1189
<http://www.holtek.com.tw>

Holtek Semiconductor Inc. (Taipei Sales Office)

4F-2, No. 3-2, YuanQu St., Nankang Software Park, Taipei 115, Taiwan
Tel: 886-2-2655-7070
Fax: 886-2-2655-7373
Fax: 886-2-2655-7383 (International sales hotline)

Holtek Semiconductor Inc. (Shenzhen Sales Office)

5F, Unit A, Productivity Building, No.5 Gaoxin M 2nd Road, Nanshan District, Shenzhen, China 518057
Tel: 86-755-8616-9908, 86-755-8616-9308
Fax: 86-755-8616-9722

Holtek Semiconductor (USA), Inc. (North America Sales Office)

46729 Fremont Blvd., Fremont, CA 94538, USA
Tel: 1-510-252-9880
Fax: 1-510-252-9885
<http://www.holtek.com>

Copyright © 2010 by HOLTEK SEMICONDUCTOR INC.

The information appearing in this Data Sheet is believed to be accurate at the time of publication. However, Holtek assumes no responsibility arising from the use of the specifications described. The applications mentioned herein are used solely for the purpose of illustration and Holtek makes no warranty or representation that such applications will be suitable without further modification, nor recommends the use of its products for application that may present a risk to human life due to malfunction or otherwise. Holtek's products are not authorized for use as critical components in life support devices or systems. Holtek reserves the right to alter its products without prior notification. For the most up-to-date information, please visit our web site at <http://www.holtek.com.tw>.