

Features

- Input Voltage from 2.6V to 5.5V
- Adjustable Output Voltage Up to 12V
- Internal 0.2Ω Low Power Switch
- Fixed PWM Switching Frequency: 1MHz
- Precision Feedback Reference Voltage: 0.6V (±2%)
- Ultra Low Shutdown Current: 0.1μA
- Embedded Loop Frequency Compensation
- Programmable OCP Threshold via External Resistor, R_{OC}
- Complete Protections: Soft Start , UVLO, OCP, OTP and OVP
- Package Type: SOT23-6

Applications

- All Single Cell Li or Dual Cell Battery Application
- Portable Equipment/Handheld Devices

General Description

The HT7991 is a current mode asynchronous step-up DC-DC converter. The fully integrated power MOSFET transistor, with its 0.2Ω drain source resistance, ensures a high level of device power efficiency. A fixed 1MHz switching frequency has been chosen to permit smaller inductors to be used in the application circuit. The error amplifier non-inverting input amplifier is connected to an internal precision 0.6V/±2% reference voltage while an integrated soft-start function reduces the inrush current during the converter start up period. The device is available in a SOT23-6 package type.

Application Circuit

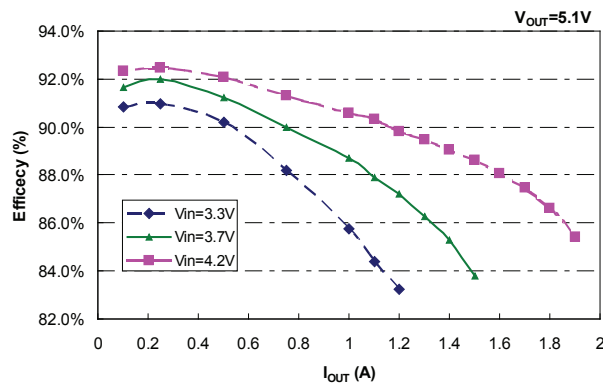
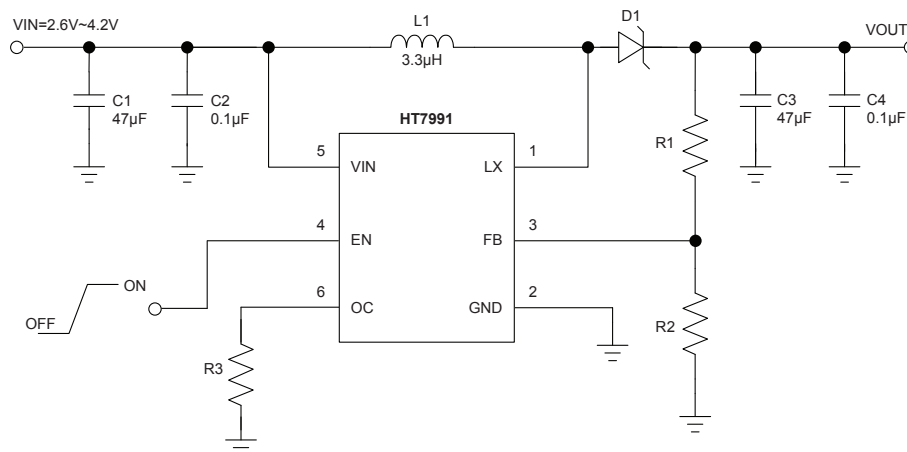

Block Diagram

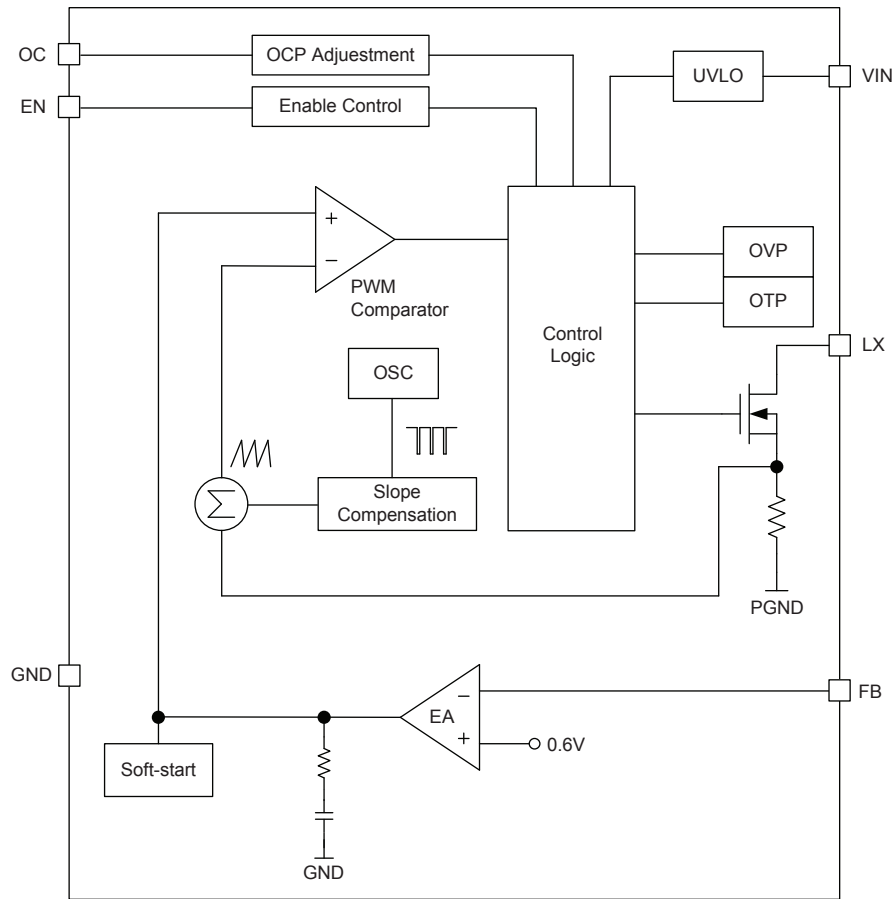

Pin Assignment

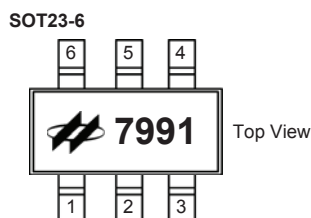

Pin Description

Pin Order	Name	Type	Pin Description
1	LX	O	Power switch output
2	GND	G	Ground terminal
3	FB	I	Error amplifier inverting input
4	EN	I	Enable control - High active
5	VIN	P	Power supply input
6	OC	I	Adjustment current limit via an external resistor to ground

Absolute Maximum Ratings

Parameter	Value	Unit
VIN	-0.3 to +6	V
LX	-0.3 to +17	V
Other Pins	+6	V
Power Dissipation	455	mW
Maximum Junction Temperature	+150	°C
Storage Temperature Range	-65 to +150	°C
Lead Temperature (Soldering 10sec)	+260	°C
ESD Susceptibility	Human Body Model	2000
	Machine Model	200
Junction-to-Ambient Thermal Resistance, θ_{JA}	220	°C/W

Recommended Operating Range

Parameter	Value	Unit
VIN	2.6 to 5.5	V
Operating Temperature Range	-40 to +85	°C

Note that Absolute Maximum Ratings indicate limitations beyond which damage to the device may occur. Recommended Operating Ratings indicate conditions for which the device is intended to be functional, but do not guarantee specified performance limits.

Electrical Characteristics

 (V_{IN}=3.3V and T_A=+25°C, unless otherwise specified)

Symbol	Parameter	Test Condition	Min	Typ	Max	Unit
Supply Voltage						
V _{IN}	Input Voltage Range	—	2.6	—	5.5	V
I _Q	Quiescent Current – Non-switching	V _{FB} =0.66V	—	210	—	μA
I _{IN}	Supply Current – Switching	V _{FB} =0.55V	—	1.5	—	mA
I _{SHDN}	Shutdown Current	V _{IN} =2.4V, V _{EN} =0V	—	0.1	1	μA
Boost Converter						
V _{OUT}	Output Voltage Range	—	3	—	12	V
f _{SW}	Switching Frequency	V _{FB} =0.5V	0.8	1.0	1.2	MHz
	Switching Frequency Variation	V _{IN} =2.6V to 5.5V	—	5	—	%
D _{MAX}	Maximum Duty Cycle	—	—	90	—	%
R _{DS}	Internal Power MOSFET Drain Source Resistance – R _{DS(ON)}	I _{LX} =2A	—	0.2	—	Ω
I _{SWL}	Driver Leakage Current	V _{EN} =0V, V _{LX} =12V	—	0.1	1	μA
V _{FB}	Feedback Voltage	—	0.588	0.6	0.612	V
	Output Voltage Line Regulation	V _{IN} =2.6V to 5.5V	—	0.2	—	%/V
V _{EN}	EN High Voltage Threshold	—	1.2	—	—	V
V _{EN}	EN Low Voltage Threshold	—	—	—	0.4	V
Protections						
V _{UVLO}	Input Supply Turn On Voltage Level	UVLO+	—	2.2	—	V
	UVLO Hysteresis	—	—	100	—	mV
I _{OCP}	Over Current Protection Threshold	OC is floating (default)	—	2.5	—	A
V _{OVP}	Output Over Voltage Threshold	OVP	—	—	17	V
t _{OTP}	Thermal Shutdown Threshold	OTP	—	150	—	°C
t _R	Thermal Recovery Temperature	—	—	125	—	°C

Typical Performance Characteristics

$V_{IN}=3.3V$, $V_{OUT}=5V$, $C_{IN}=22\mu F+22\mu F$, $C_{OUT}=22\mu F+22\mu F$, $L=3.3\mu H$, $T_A=25^\circ C$, unless otherwise noted

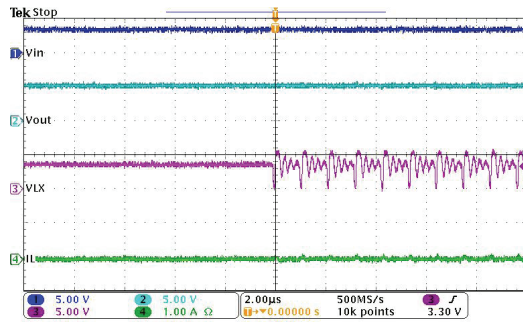

Steady State: $I_{OUT}=0A$

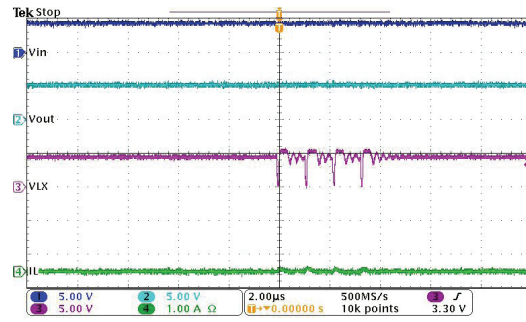

Steady State: $V_{IN}=4.2V$, $I_{OUT}=0A$

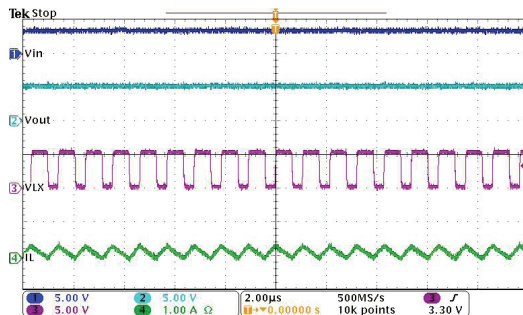

Steady State: $I_{OUT}=0.1A$

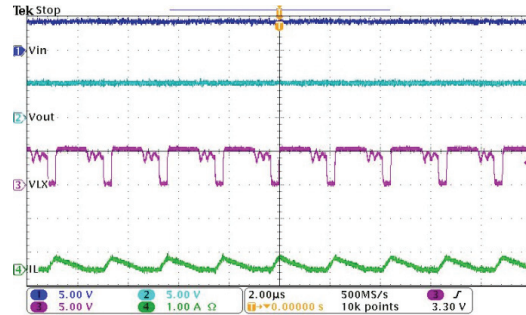

Steady State: $V_{IN}=4.2V$, $I_{OUT}=0.1A$

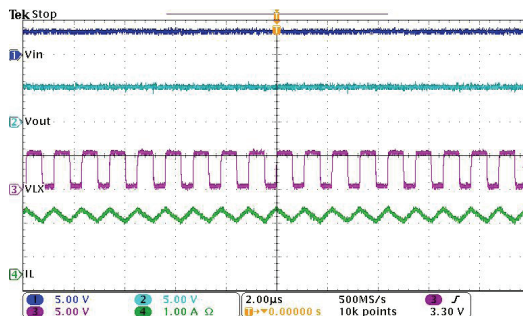

Steady State: $I_{OUT}=1.0A$

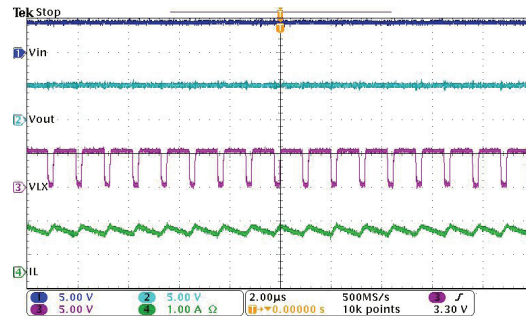

Steady State: $V_{IN}=4.2V$, $I_{OUT}=1.0A$

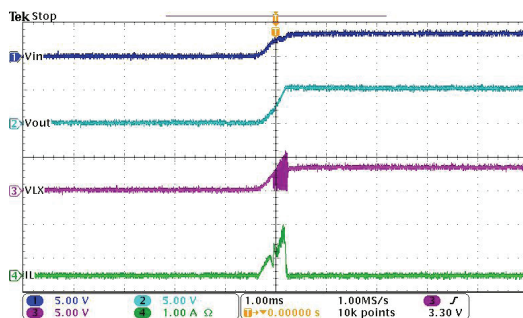

Start Up from V_{IN} : $I_{OUT}=0A$

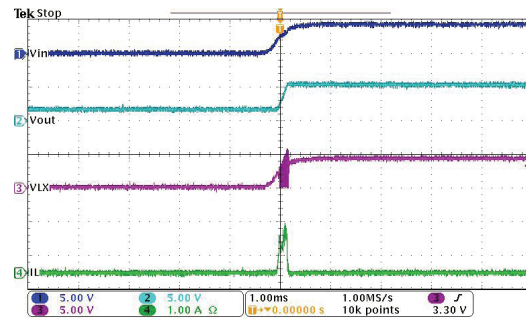

Start Up from V_{IN} : $V_{IN}=4.2V$, $I_{OUT}=0A$

$V_{IN}=3.3V$, $V_{OUT}=5V$, $C_{IN}=22\mu F+22\mu F$, $C_{OUT}=22\mu F+22\mu F$, $L=3.3\mu H$, $T_A=25^\circ C$, unless otherwise noted

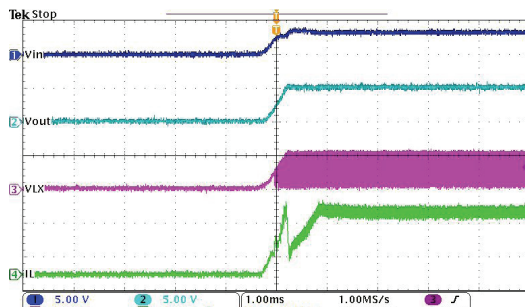

Start Up from V_{IN} : $I_{OUT}=1A$

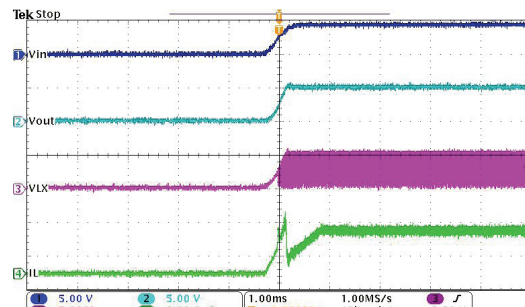

Start Up from V_{IN} : $V_{IN}=4.2V$, $I_{OUT}=1A$

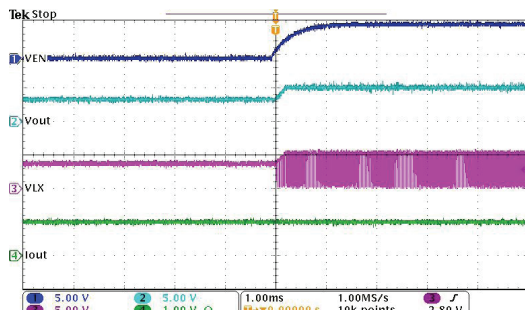

Start Up from EN : $I_{OUT}=1A$

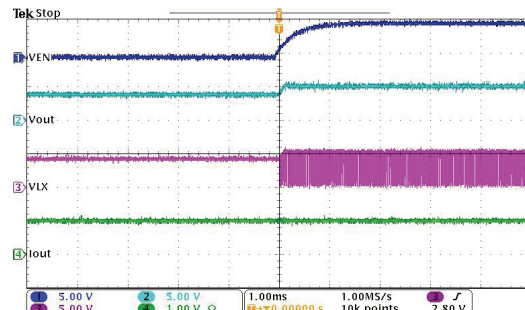

Start Up from EN : $V_{IN}=4.2V$, $I_{OUT}=1A$

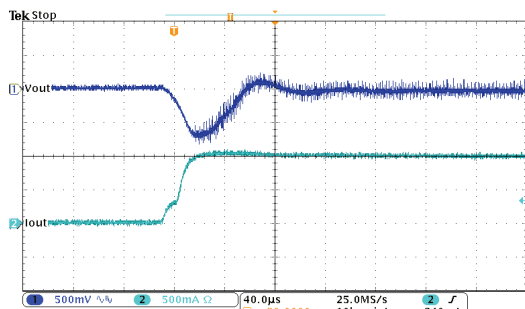

Load Transient: $V_{IN}=3.3V$, $V_{OUT}=5V$

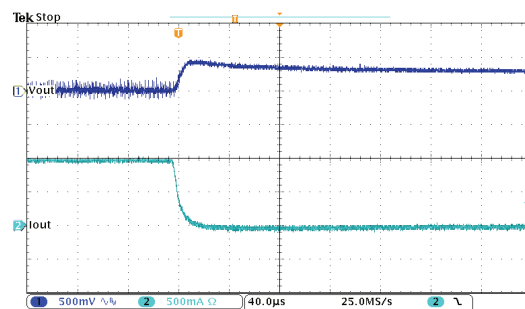

Load Transient: $V_{IN}=3.3V$, $V_{OUT}=5V$

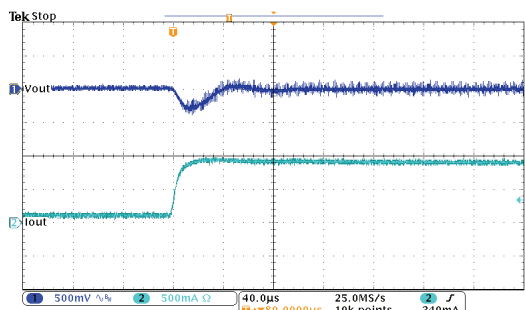

Load Transient: $V_{IN}=4.2V$, $V_{OUT}=5V$

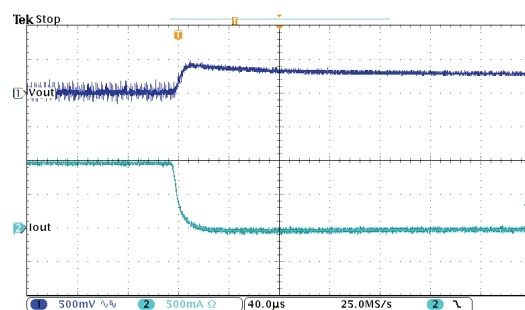

Load Transient: $V_{IN}=4.2V$, $V_{OUT}=5V$

$V_{IN}=3.3V$, $V_{OUT}=5V$, $C_{IN}=22\mu F+22\mu F$, $C_{OUT}=22\mu F+22\mu F$, $L=3.3\mu H$, $T_A=25^\circ C$, unless otherwise noted

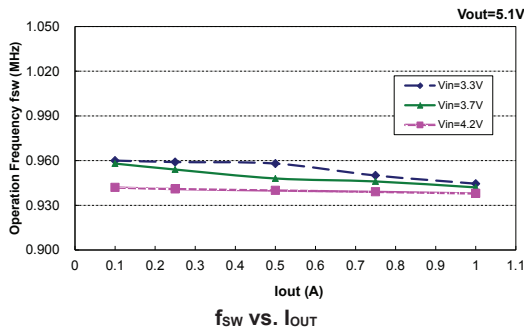
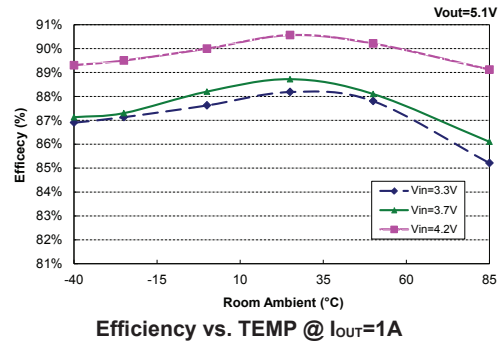
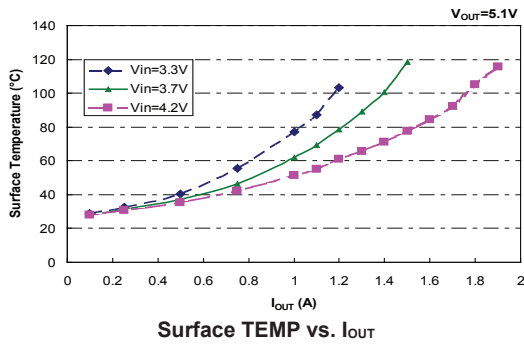
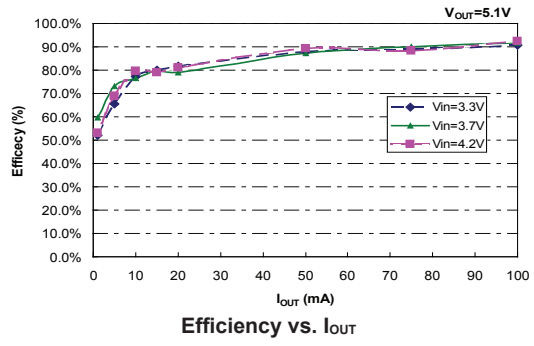
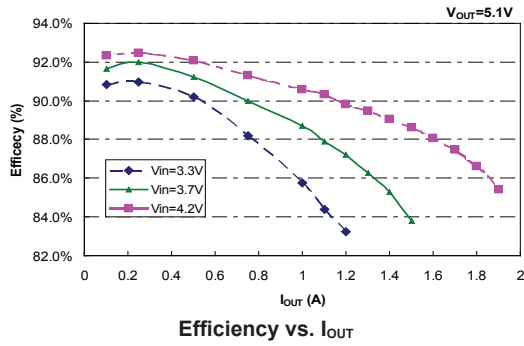

Functional Description

Operation

The HT7991 is an asynchronous step-up dc/dc converter. With a wide input range from 2.6V to 5.5V, the HT7991 is suitable for portable Li-battery based applications such as power banks. Thanks for the high operation switching frequency, 1MHz, the HT7991 allows the use of small external components while still being able to have low output voltage ripple. The embedded loop frequency compensation circuitry simplifies the system design and reduces the external components.

Setting Output Voltage

The external resistor divider sets the output voltage (see Typical Application Circuit). The feedback resistor, R1, also sets the feedback loop bandwidth with the internal compensation capacitor. R1 and R2 are calculated in equation:

$$R2 = R1 / ((V_{OUT} / 0.6V) - 1) \quad (\Omega)$$

Protections

The HT7991 has dedicated protection circuitry running during normal operation to protect the IC. The Soft Start function (SS) is set around 1ms internally to prevent the inrush current during power-on period. The Over Current Protection (OCP) is illustrated in detail below. The Over Temperature Protection (OTP) turns off the power device when the die temperature reaches excessive levels. The Under Voltage Lock-Out comparator (UVLO) protects the power device during supply power startup and shutdown to prevent operation at voltages less than the minimum input voltage. HT7991 restricts 17V maximum output voltage (OVP) to avoid the burn-out of the internal components and the output devices.

Setting Over Current Threshold Via External Resistor

In default, HT7991 sets the maximum peak current passing through the internal power MOSFET restricted to 2.5A when OC pin keeps floating via a resistor. The R_{OC} resistor value is normally set between 19.2kΩ and 30kΩ. The current limit will be set from 1.6A to 2.5A. Do not put the capacitor at this pin. The approximate OCP trip point could be calculated according the equation:

$$I_{OCP} = 48000 / R_{OC} \quad (A)$$

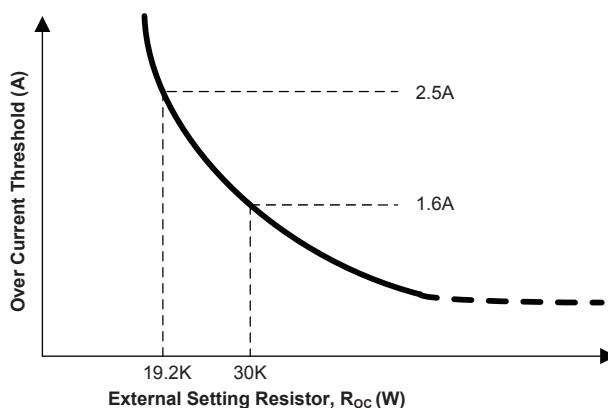

Component Selection Guide

Inductor

The selected inductor should have a saturation current that meets the maximum peak current of the converter. Another important inductor parameter is the dc resistance. The lower the dc resistance gains the higher the efficiency of the converter. For most applications, the inductor value can be calculated from the following equation:

$$L = \left(\frac{V_{in}}{V_{out}}\right)^2 \times \frac{(V_{out} - V_{in})}{I_{ripple} \times f_{sw}}$$

The higher value of ripple current reduces inductance, but the conductance loss, core loss, and current stress of the inductor and switching devices increase. It's suggested that choosing the inductor ripple current to be 30% of the maximum load current.

Diode

The breakdown voltage rating of the diode is preferred to be higher than the maximum input voltage. The current rating for the diode should be equal to the maximum output current for best reliability in most applications. In this case, it is possible to use a diode with a lower average current. However the peak current should be higher than the maximum load current.

Input Capacitor

A low ESR ceramic capacitor is needed between the VIN pin and GND pin. Use ceramic capacitors with X5R or X7R dielectrics for its low ESR and small temperature coefficients. For most applications, the capacitance in the range of 2.2μF to 10μF capacitor is sufficient.

Output Capacitor

The selection of output capacitor is driven by the maximum allowable output voltage ripple. Using ceramic capacitors with X5R or X7R dielectrics for its low ESR characteristic is suggested. The capacitance in the range of 10μF to 100μF is sufficient.

Recommended Component Values

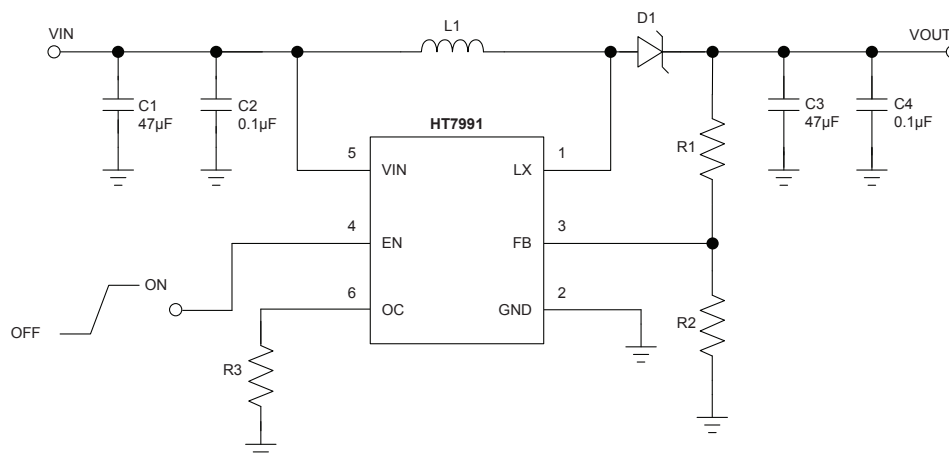

V _{OUT} (V)	R1 (kΩ)	R2 (kΩ)	C3 (μF)	C4 (μF)	L1 (μH)
5.1	75 (1%)	10 (1%)	47	0.1	3.3
12.0	190 (1%)	10 (1%)	47	0.1	6.8

Layout Consideration Guide

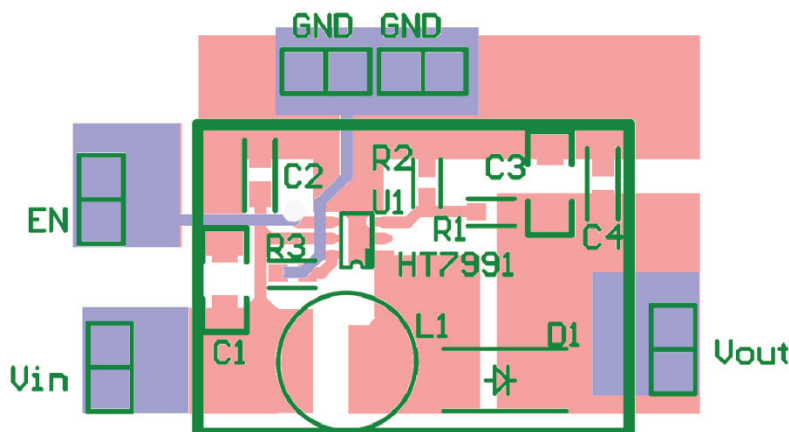

Suggested Layout

To reduce problems with conducted noise, PCB layout is very important to stability. The layout recommendations are listed below:

- (1) The input bypass capacitor must be placed close to the VIN pin.
- (2) The inductor, schottky diode, and output capacitor trace should be as short as possible to reduce conducted and radiated noise and increase overall efficiency.
- (3) Keep the power ground and supply paths as short and wide as possible.

Thermal Considerations

For continuous operation, do not exceed the absolute maximum junction temperature. The maximum power dissipation depends on the thermal resistance of the IC package, PCB layout, rate of surrounding airflow, and the allowed difference between the junction and ambient temperatures. The maximum power dissipation can be calculated by the following formula:

$$P_{D(MAX)} = (T_{J(MAX)} - T_A) / \theta_{JA} \quad (W)$$

Where $T_{J(MAX)}$ is the maximum junction temperature, T_A is the ambient temperature, and θ_{JA} is the junction to ambient thermal resistance.

The recommended operating conditions specify a maximum junction temperature is 125°C. The junction to ambient thermal resistance, θ_{JA} , is layout dependent. On a standard JEDEC 51-7 four-layer thermal test board, the thermal resistance, θ_{JA} , of the QFN-10 package is 50°C/W. The maximum power dissipation at $T_A=25^\circ\text{C}$ can be calculated by the following formula.

$$P_{D(MAX)} = (125^\circ\text{C} - 25^\circ\text{C}) / (220^\circ\text{C/W}) = 455\text{mW}$$

For a fixed $T_{J(MAX)}$ of 125°C, the maximum power dissipation depends on the operating ambient temperature and the package's thermal resistance, θ_{JA} . The de-rating curve below shows the effect of rising ambient temperature on the maximum recommended power dissipation.

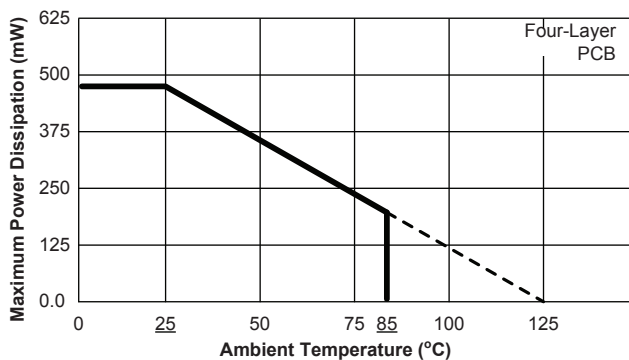

Package Information

Note that the package information provided here is for consultation purposes only. As this information may be updated at regular intervals users are reminded to consult the [Holtek website](#) for the latest version of the [package information](#).

Additional supplementary information with regard to packaging is listed below. Click on the relevant section to be transferred to the relevant website page.

- Further Package Information (include Outline Dimensions, Product Tape and Reel Specifications)
- Packing Materials Information
- Carton information

6-pin SOT23-6 Outline Dimensions

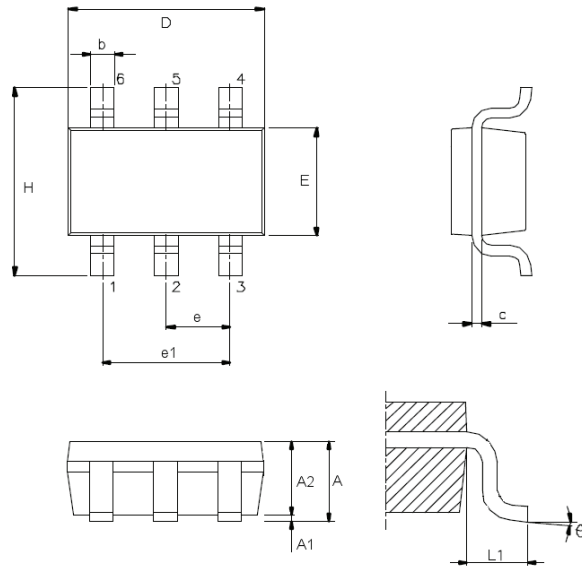

Symbol	Dimensions in inch		
	Min.	Nom.	Max.
A	—	—	0.057
A1	—	—	0.006
A2	0.035	0.045	0.051
b	0.012	—	0.020
C	0.003	—	0.009
D	—	0.114 BSC	—
E	—	0.063 BSC	—
e	—	0.037 BSC	—
e1	—	0.075 BSC	—
H	—	0.110 BSC	—
L	0.012	0.018	0.024
θ	0°	—	8°

Symbol	Dimensions in mm		
	Min.	Nom.	Max.
A	—	—	1.45
A1	—	—	0.15
A2	0.90	1.15	1.30
b	0.30	—	0.50
C	0.08	—	0.22
D	—	2.90 BSC	—
E	—	1.60 BSC	—
e	—	0.95 BSC	—
e1	—	1.90 BSC	—
H	—	2.80 BSC	—
L	0.30	0.45	0.60
θ	0°	—	8°

Copyright© 2018 by HOLTEK SEMICONDUCTOR INC.

The information appearing in this Data Sheet is believed to be accurate at the time of publication. However, Holtek assumes no responsibility arising from the use of the specifications described. The applications mentioned herein are used solely for the purpose of illustration and Holtek makes no warranty or representation that such applications will be suitable without further modification, nor recommends the use of its products for application that may present a risk to human life due to malfunction or otherwise. Holtek's products are not authorized for use as critical components in life support devices or systems. Holtek reserves the right to alter its products without prior notification. For the most up-to-date information, please visit our web site at <http://www.holtek.com.tw>.