

Feature

- High Performance, Low Cost Current Mode PWM Controller especially designed for Energy Star 5.0
- Very Low Startup Current (<math><20\mu\text{A}</math>) and Operating Current
- High-Voltage CMOS Process with Excellent ESD protection (>3KV)
- $\pm 5\%$ Trimmed Oscillator for Precise Frequency Control
- LEB (Leading-Edge Blanking) on CS Pin
- Internal Slope Compensation
- Programmable Switching Frequency
- Internally Trimmed Reference with UVLO (Under Voltage Lockout)
- Cycle-by-Cycle Current Limiting

Applications

- Switching AC-DC Adaptors
- DC-DC Switching Buck/Boost Converters
- LED Backlights for LCD/LED TVs

General Description

The HT7A6005 is a controller IC that includes the necessary features to implement off-line or DC-DC current mode control schemes with a minimal external parts count. Internal circuits include a specially designed Mixed-Mode/Analog Interface for multi-function and multi-topology control schemes (DC-DC Buck/Boost, Off-line AC-DC), a trimmed oscillator for precise duty-cycle control under voltage lockout with a start-up current of less than 0.5mA, a wide temperature range, precise voltage reference, internal Slope Compensation and Leading-Edge Blanking. The HT7A6005 features basic system protection functions such as Cycle-by-Cycle Current Limiting and Under Voltage Lock-Out (UVLO).

A Multi-Function Pin can be used as a dimming function for LED driving, and as a primary feedback control for Primary-Side Feedback AC-DC applications.

Application Circuits

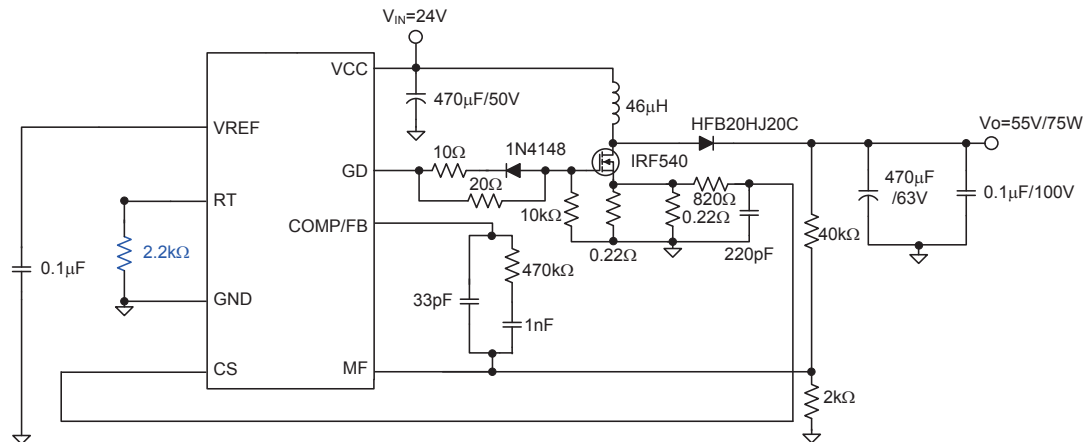

Block Diagram

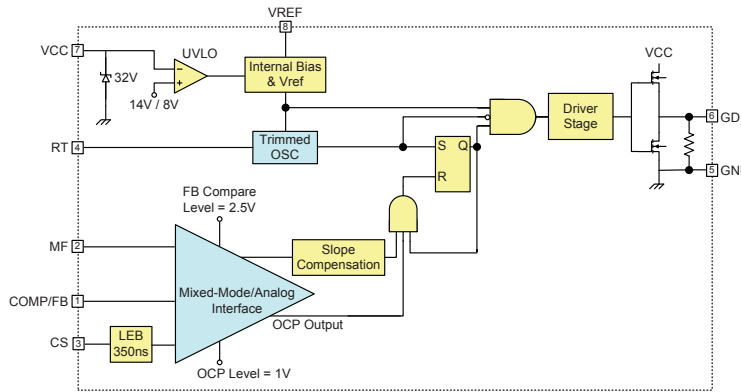

Pin Assignment

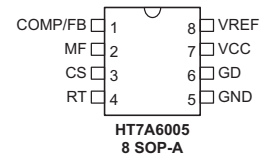

Pin Description

Pin No.	Pin Name	Description
1	COMP/FB	Voltage Feedback Pin, Connected to a system voltage feedback point.
2	MF	Multi-Function Pin. By connecting this pin to different system sensing points, the device can be used for different circuit topologies such as Isolation Flyback or Non-Isolation DC-DC Buck/Boost.
3	CS	A voltage proportional to the inductor current is connected to this input. The PWM generator uses this voltage to terminate output switching.
4	RT	The oscillator frequency is programmed by connecting a resistor, RT, between this pin and ground. A maximum frequency of 500kHz is possible.
5	GND	Combined control circuitry and power ground.
6	GD	Power MOSFET gate driver output.
7	VCC	Positive Supply.
8	VREF	Temperature-independent voltage reference output.

Absolute Maximum Ratings

Supply Voltage VCC	-0.3V~30.0V
COMP/FB, RT, CS, MF Pins	-0.3V~5.0V
Junction Temperature	150°C
Operating Ambient Temperature	-40°C~85°C
Storage Temperature Range	-65°C~150°C
Package Thermal Resistance (8-Pin SOP)	160°C/W
ESD Protection:	
Human Body Model	3kV
Machine Model	200V

Note: These are stress ratings only. Stresses exceeding the range specified under “Absolute Maximum Ratings” may cause substantial damage to the device. Functional operation of this device at other conditions beyond those listed in the specification is not implied and prolonged exposure to extreme conditions may affect device reliability.

Electrical Characteristics

Unless otherwise stated, this specifications apply for $0^{\circ}\text{C} \leq T_a \leq 70^{\circ}\text{C}$, $V_{CC}=15\text{V}$, $RT=10\text{k}\Omega$

Symbol	Parameter	Test Condition	Min.	Typ.	Max.	Unit
Supply Voltage (VCC Pin)						
I_{ST}	Startup Current	$V_{CC}=7.7\text{V}$	—	12	30	μA
I_{CC}	Operating Current	$V_{FB}=V_{CS}=0\text{V}$	—	2.0	3.0	mA
V_{TL}	UVLO (Off)	—	7.0	7.6	8.2	V
V_{TH}	UVLO (On)	—	7.8	8.4	9.0	V
Reference Section						
V_{REF}	Output Voltage	$T_j = 25^{\circ}\text{C}$, $I_o = 1\text{mA}$	4.85	5.00	5.15	V
ΔV_{REF}	Line Regulation	$12\text{V} \leq V_{CC} \leq 25\text{V}$	—	3	20	mV
ΔV_{REF}	Load Regulation	$1\text{mA} \leq I_o \leq 10\text{mA}$	—	4	25	mV
Current Sensing (CS Pin)						
$V_{CS(OFF)}$	Maximum Input Voltage	—	0.9	1.0	1.1	V
t_{LEB}	Leading Edge Blanking Time	—	—	350	—	ns
	Delay to Output	—	—	100	—	ns
Oscillator (RT pin)						
f_{OSC}	Oscillator Frequency	$T_j=25^{\circ}\text{C}$, $RT=10\text{k}\Omega$	47	52	57	kHz
$\frac{\Delta f_{OSC}}{\Delta T_A}$	Tempurature Stability	$-40^{\circ}\text{C} \sim 105^{\circ}\text{C}$	—	5	—	$\%$
$\frac{\Delta f_{OSC}}{\Delta V_{REF}}$	Voltage Stability	$V_{CC}=10\text{V} \sim 25\text{V}$	—	0.2	1.0	$\%$
D_{MAX}	Maximum Duty	—	—	97	—	$\%$
Gate Drive Output (GD Pin)						
V_{OL}	Output Low Level	$V_{CC}=15\text{V}$, $I_{sink}=20\text{mA}$	—	—	1	V
V_{OH}	Output High Level	$V_{CC}=15\text{V}$, $I_{source}=20\text{mA}$	9	—	—	V
t_r	Rising Time	$T_j=25^{\circ}\text{C}$, Load Capacitance=1nF	—	50	150	ns
t_f	Falling Time	$T_j=25^{\circ}\text{C}$, Load Capacitance=1nF	—	50	150	ns
Voltage Feedback (COMP/FB Pin)						
V_{COMP}	Open Loop Voltage	COMP/FB pin open	—	5	—	V
V_{REFA}	Reference Voltage	$V_{FB/PDM}=2.5\text{V}$	2.42	2.50	2.58	V
I_{SINKA}	Output Sink Current	$V_{FB}=2.7\text{V}$, $V_{FB/PDM}=1.1\text{V}$	2	7	—	mA
$I_{SOURCEA}$	Output Source Current	$V_{FB}=2.3\text{V}$, $V_{FB/PDM}=4.8\text{V}$	-0.5	-1.0	—	mA
V_{OHA}	$V_{COMP/FB}$ High Voltage	$V_{FB}=2.3\text{V}$, $RL=15\text{k}\Omega$ to GND	4.8	5.0	—	V
V_{OLA}	$V_{COMP/FB}$ Low Voltage	$V_{FB}=2.7\text{V}$, $RL=15\text{k}\Omega$ to Vref	—	0.8	1.1	V
A_{VO}	DC Gain	—	—	150	—	dB

Note: These Parameters, although guaranteed, are not 100% tested in production.

Typical Performance Characteristics

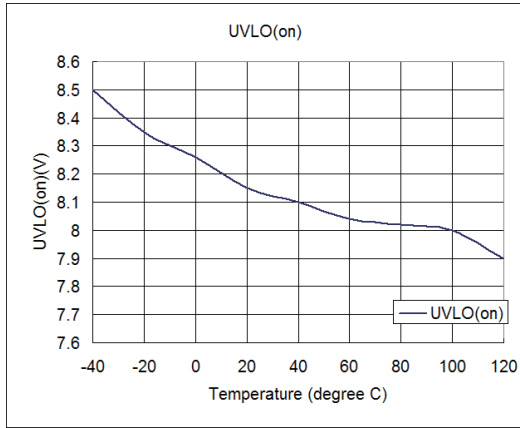

Figure 1. UVLO (on) (V) vs Temperature

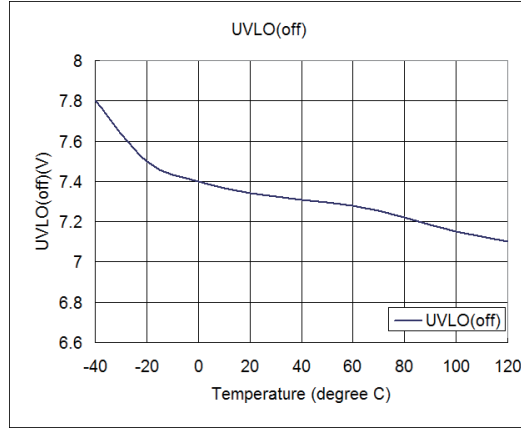

Figure 2. UVLO (off)(V) vs Temperature

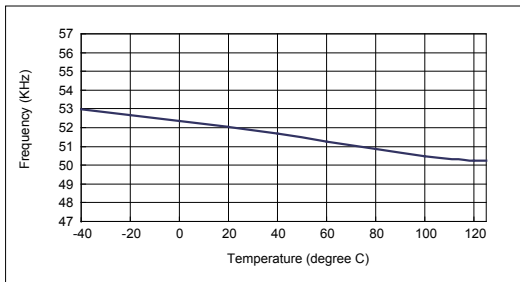

Figure 3. Frequency vs Temperature

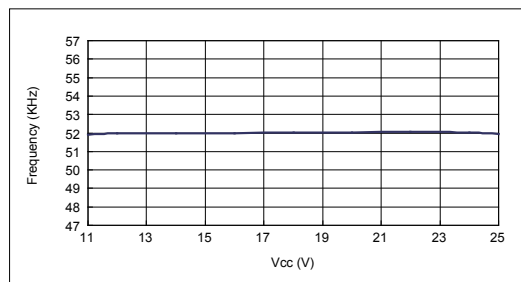

Figure 4. Frequency vs Vcc

Application Information

Operation Overview

The HT7A6005 is a low power, wide temperature range general purpose current mode PWM Controller. The device is designed to require a minimum of external components for different power circuit topologies such as Primary-Side Feedback Flyback and DC-DC Buck/Boost. The device can be used for LED driving applications such as LED backlights and LED lighting. To meet LED constant current requirements, the device can maintain a low current tolerance of $\pm 1\%$ for LED driving applications.

Under Voltage Lockout (UVLO)

A UVLO comparator is provided to ensure that the device is fully functional before the output stage is enabled. As shown in Figure 5, hysteresis is provided to prevent the PWM Controller from shutting down during any voltage dips which might occur during the startup process. The turn-on and turn-off threshold levels are set at 8.4V and 7.6V, respectively.

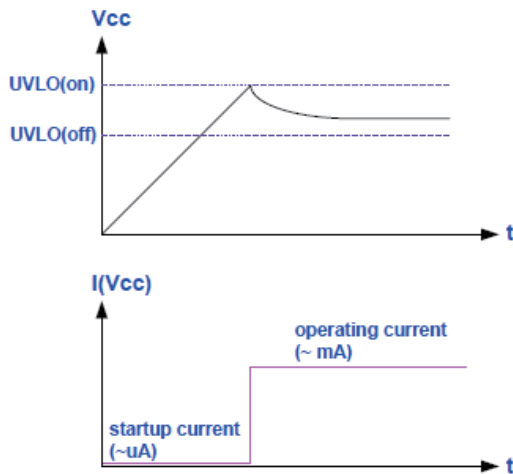

Figure 5. UVLO Scheme and Start-Up Current

Current Sense and Leading-Edge Blanking (LEB)

For Isolation Flyback applications, a Leading-Edge Blanking Scheme is necessary. A Leading-Edge Blanking Scheme is integrated in the device to prevent false triggering due to feedback current spikes which may appear on the CS pin. This eliminates the need for the usual R-C filter which is normally a requirement in typical current mode PWM Controller applications.

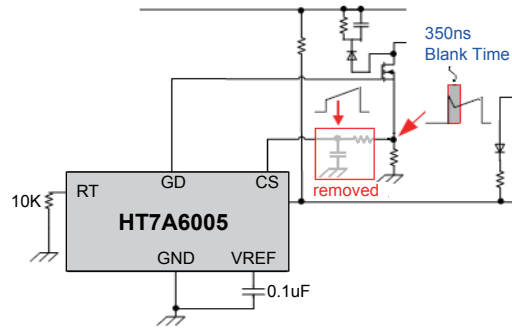

Figure 6. LEB with R-C Filter Removed

Internal Slope-Compensation

An important issue with current mode control schemes is instability due to sub-harmonic oscillation when the Duty-Cycle $> 50\%$. To prevent this problem from occurring, a Slope-Compensation function is always necessary. In traditional current mode controller applications, many external components are necessary to implement a Slope-Compensation function. However in the HT7A6005 the internal Slope-Compensation function eliminates the need for these external components resulting in a simplified application circuit design.

Oscillator Frequency Tuning

By choosing an appropriate value of external resistor between the RT Pin and GND, a suitable operating frequency can be generated. The relationship between the RT value and the operating frequency is provided in Figure 7.

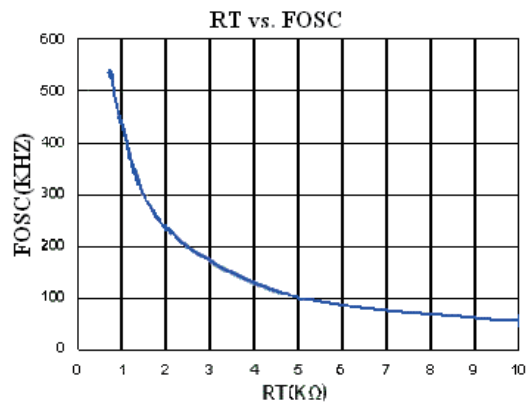

Figure 7. RT Resistor Value vs. Operating Frequency

Multi-Function Pin

A specially designed Mixed-Signal/Analog Interface is provided in the HT7A6005. By connecting the Multi-Function (MF) pin to different system sensing points, the HT7A6005 can be used for different circuit topologies such as Isolation Flyback or Non-Isolation DC-DC Buck/Boost. The MF pin can also be used as an LED dimming pin for Buck LED driving. Some application circuit examples are introduced in the following pages.

Constant Voltage Boost Application

A Constant Voltage (CV) Boost application circuit is shown in Figure 8. This circuit can be used with DC inputs of 16~24V and provides a DC output of 55V \pm 5% with 75W output power. The output power level can be changed by choosing a suitable inductor value and power MOSFET, while the output voltage can be changed by choosing a suitable feedback resistor ratio.

Boost Constant Current (CC) LED Driver for Back-light

A Boost CC LED Driver shown in Figure 9 is designed for LED backlight applications. The topology is similar to Boost topologies, but the feedback point is changed from the Voltage Output terminal to the Current Sense Resistor. This circuit can be used with a DC input of 16~24V and provides a DC output of 55V with 75W output power. This circuit's constant current capability is more than that required by backlights and also good enough for LED lighting applications.

Buck Constant Current LED Lighting Driver

A low cost Buck Constant Current LED Lighting driver is introduced in Figure 10. Unlike the usual LED drives which have a fixed-voltage range and constant current control, this circuit can support very high output voltages, perhaps for high LED count serial configurations, with no maximum voltage limitations. Here the MF pin can be used as a PWM dimming pin.

Constant Voltage Buck Application

A Constant Voltage (CV) Buck (High-Side Buck) application circuit is shown in Figure 11. This circuit can be used with DC inputs of 24V or higher voltage and provides a Constant DC voltage output. The output power level can be changed by choosing a suitable inductor value, Transformer's turn ratio and power MOSFET, while the output voltage can be changed by choosing a suitable feedback resistor ratio.

Primary Side Feedback, Isolation Flyback AC-DC Converter

The device can also be used for isolation AC-DC applications. A typical primary side feedback, isolation Flyback AC-DC converter is shown in Figure 12.

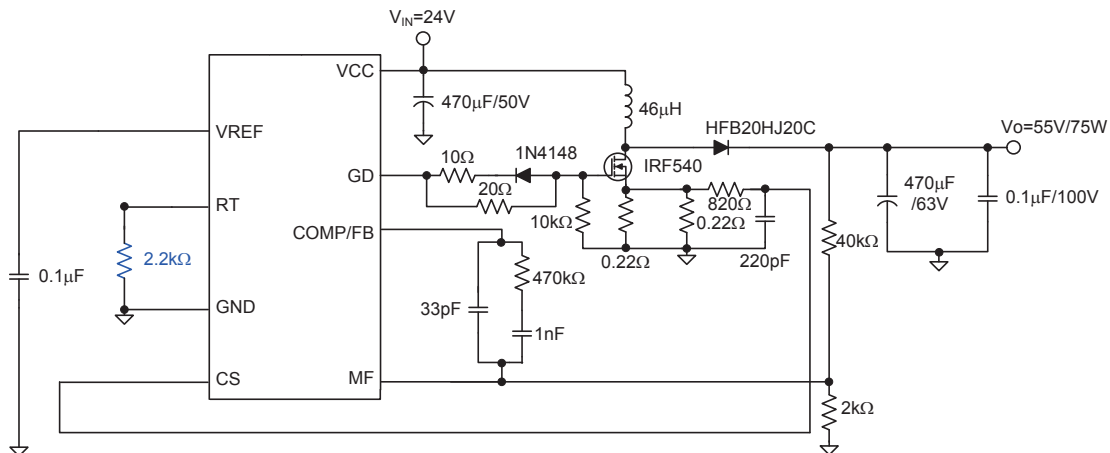

Figure 8. Constant Voltage Boost Application (DC-DC Boost)

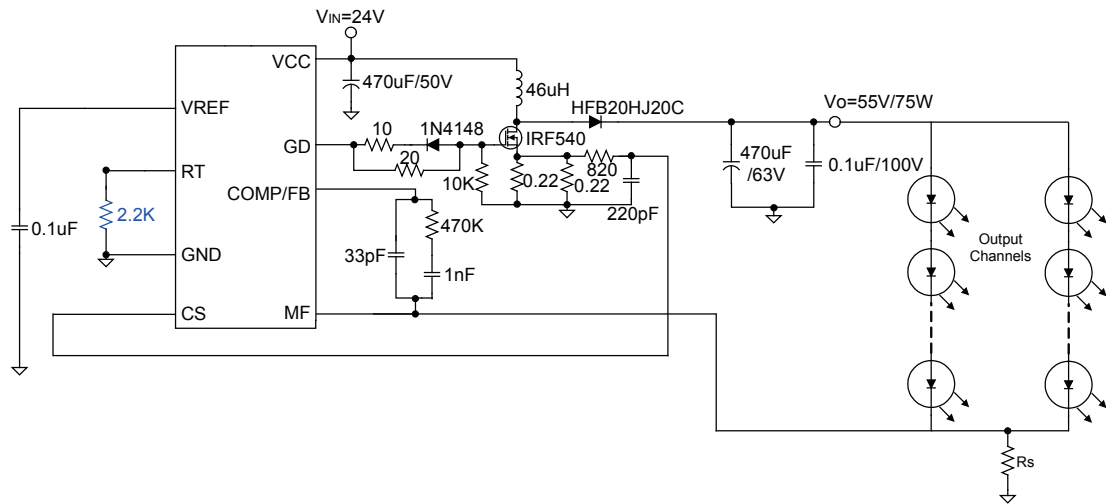

Figure 9. DC-DC Boost Constant Current (CC) LED Driver for Back-light

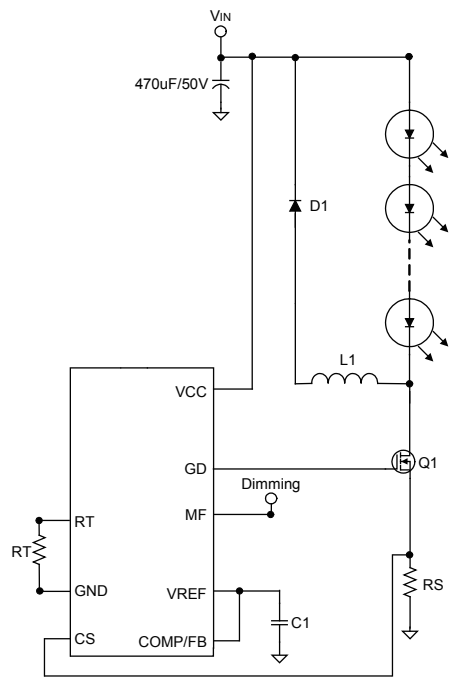

Figure 10. Buck Constant Current LED Lighting Driver

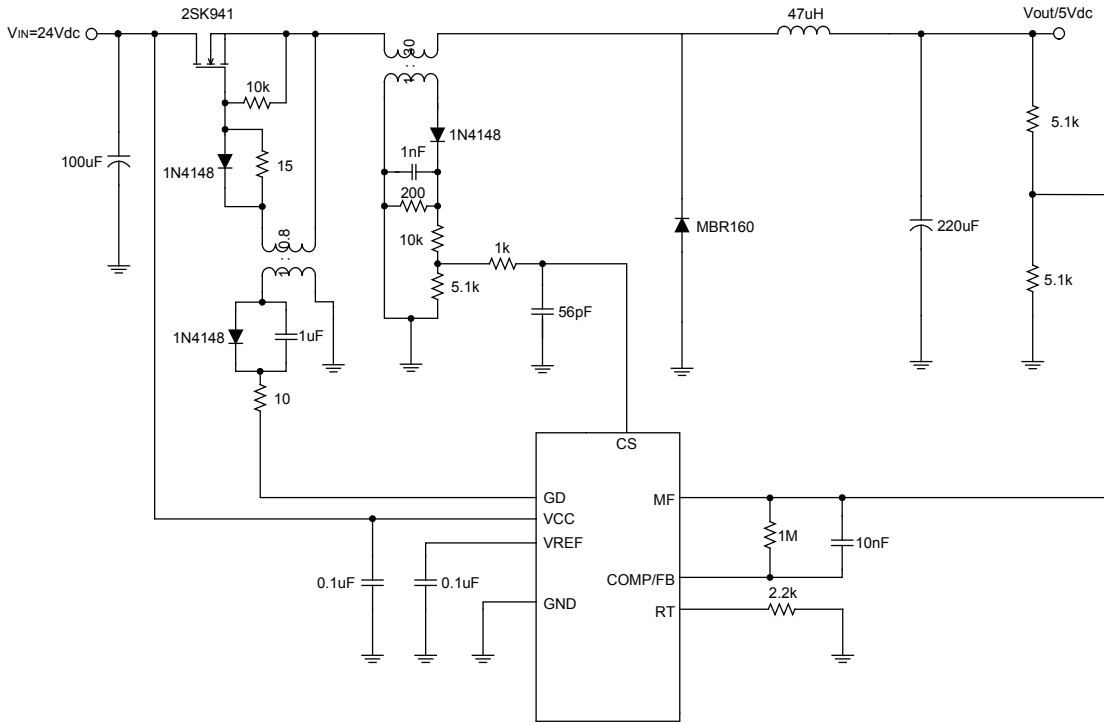

Figure 11. Constant Voltage Buck Regulator (High-Side Buck)

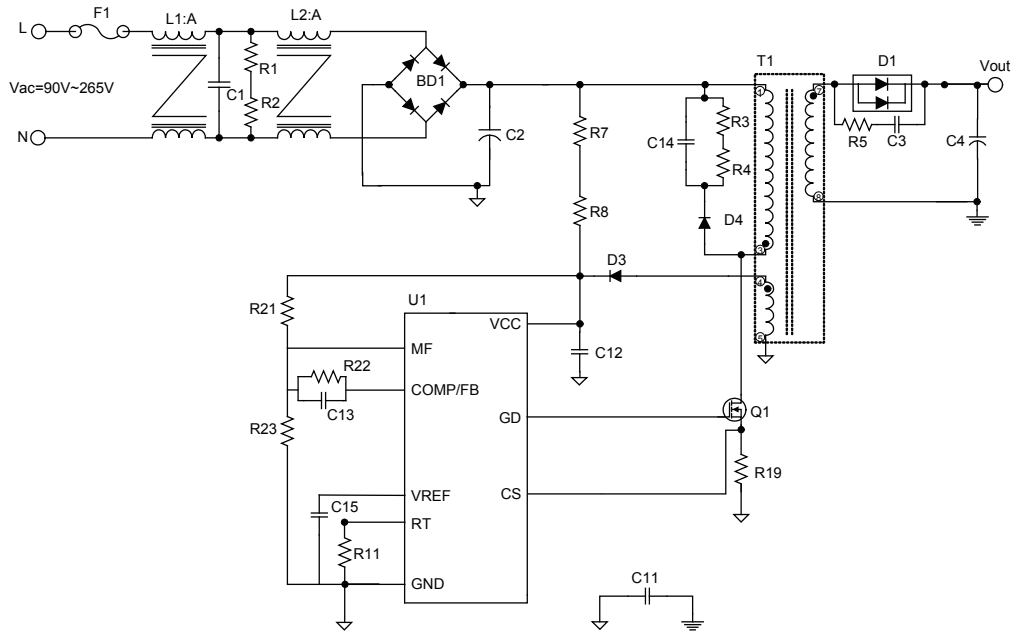

Figure 12. Primary Side Feedback, Isolation Flyback AC-DC Converter

Package Information

Note that the package information provided here is for consultation purposes only. As this information may be updated at regular intervals users are reminded to consult the [Holtek website](#) for the latest version of the [Package/ Carton Information](#).

Additional supplementary information with regard to packaging is listed below. Click on the relevant section to be transferred to the relevant website page.

- Package Information (include Outline Dimensions, Product Tape and Reel Specifications)
- The Operation Instruction of Packing Materials
- Carton information

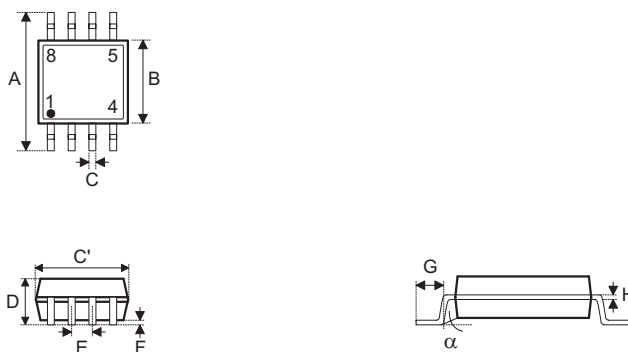
8-pin SOP (150mil) Outline Dimensions

Symbol	Dimensions in inch		
	Min.	Nom.	Max.
A	0.228	—	0.244
B	0.150	—	0.157
C	0.012	—	0.020
C'	0.188	—	0.197
D	—	—	0.069
E	—	0.050	—
F	0.004	—	0.010
G	0.016	—	0.050
H	0.007	—	0.010
α	0°	—	8°

Symbol	Dimensions in mm		
	Min.	Nom.	Max.
A	5.79	—	6.20
B	3.81	—	3.99
C	0.30	—	0.51
C'	4.78	—	5.00
D	—	—	1.75
E	—	1.27	—
F	0.10	—	0.25
G	0.41	—	1.27
H	0.18	—	0.25
α	0°	—	8°

Copyright© 2013 by HOLTEK SEMICONDUCTOR INC.

The information appearing in this Data Sheet is believed to be accurate at the time of publication. However, Holtek assumes no responsibility arising from the use of the specifications described. The applications mentioned herein are used solely for the purpose of illustration and Holtek makes no warranty or representation that such applications will be suitable without further modification, nor recommends the use of its products for application that may present a risk to human life due to malfunction or otherwise. Holtek's products are not authorized for use as critical components in life support devices or systems. Holtek reserves the right to alter its products without prior notification. For the most up-to-date information, please visit our web site at <http://www.holtek.com>.