

Features

- Fixed 60kHz switching frequency
- 9V to 38V wide range V_{CC} voltage
- Wide AC input range from $85V_{AC}$ to $265V_{AC}$
- PWM with current mode control
- Auxiliary Under Voltage Lock Out with hysteresis
- High voltage start-up current source
- Excellent standby low power consumption
- Over-temperature, Over-current and Over-voltage protection with auto-restart
- Integrated 730V MOSFET
- Burst mode under low load conditions

Applications

- Off line power supply for battery charger adapters
- Standby power supply for TV or monitors
- Auxiliary supply for motor control
- Air conditioner power supply
- Electromagnetic oven power supply

General Description

The HT7A6312 is highly functionally integrated device which combines an integrated PWM controller with current mode control and a high voltage power MOSFET on the same silicon chip.

Typical Power Capability

Type	8SOP	8DIP
European ($195\sim 265V_{AC}$)	8W	13W
US ($85\sim 265V_{AC}$)	5W	8W

Typical Performance Characteristics Application Circuit

Isolation Flyback Topology

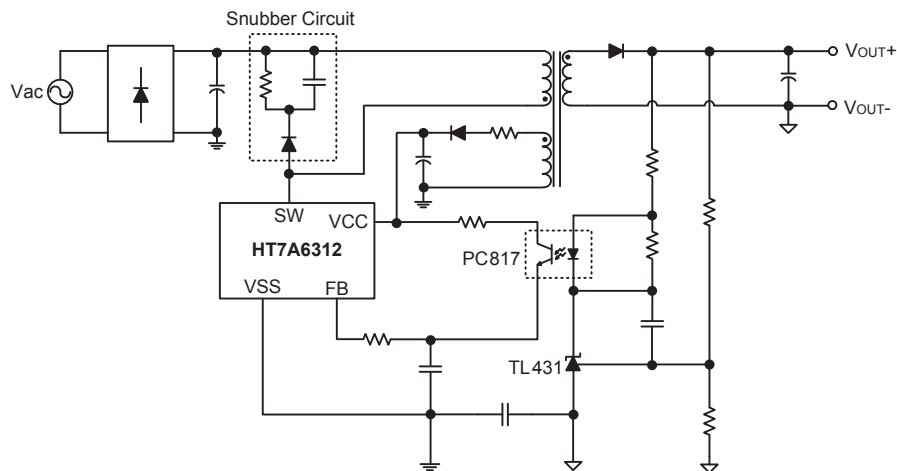

Block Diagram

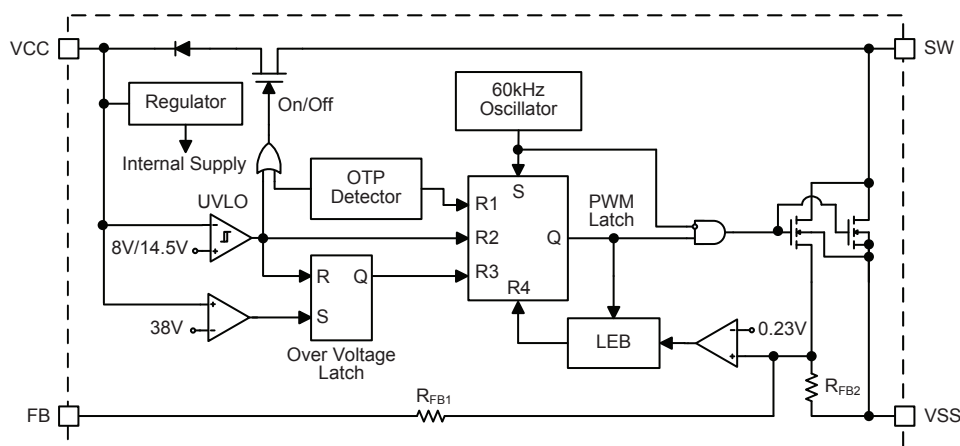

Pin Assignment

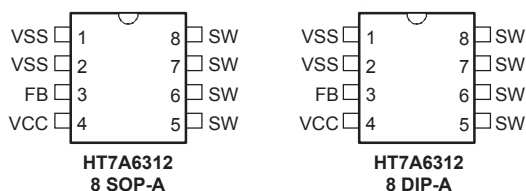

Pin Description

Pin No.		Pin Name	Description
8SOP	8DIP		
1, 2	1, 2	VSS	Power MOSFET source and circuit ground reference.
3	3	FB	Feedback input. The useful voltage range extends from 0V to 1V, and defines the peak drain MOSFET current. The current limitation, which corresponds to the maximum drain current, is obtained for when the FB pin is shorted to the VSS pin.
4	4	VCC	Control circuits power supply. Also provides a charging current during start up thanks to a high voltage current source connected to SW. For this purpose, a hysteresis comparator monitors the V _{CC} voltage and provides two thresholds: V _{CCON} : Voltage value (typically 14.5V) at which the device starts switching and turns off the start up current source. V _{CCOFF} : Voltage value (typically 8V) at which the device stops switching and turns on the start up current source.
5, 6, 7, 8	5, 6, 7, 8	SW	Power MOSFET drain. Also used by the internal high voltage current source during the start up phase to charge the external V _{CC} capacitor.

Absolute Maximum Ratings

Symbol	Parameter	Value	Unit
$V_{DS(sw)}$	Switching Drain Source Voltage ($T_J=25$ to $125^{\circ}C$) ⁽¹⁾	-0.3 to 730	V
$V_{DS(st)}$	Start-up Drain Source Voltage ($T_J=25$ to $125^{\circ}C$) ⁽²⁾	-0.3 to 400	V
I_D	Continuous Drain Current	Internally limited	A
V_{CC}	Supply Voltage	0 to 41	V
I_{FB}	Feedback Current	3	mA
V_{ESD}	Electrostatic Discharge: Machine mode	400	V
	Electrostatic Discharge: Human body mode	3	kV
T_C	Operating Temperature Range	-40 to 150	$^{\circ}C$
T_{STG}	Storage Temperature Range	-55 to 150	$^{\circ}C$
T_J	Junction Operating Temperature	Internally limited	$^{\circ}C$

Note: 1. This parameter applies when the start-up current source is off. This is the case when the V_{CC} voltage has reached V_{CCON} and remains above V_{CCOFF} .

2. This parameter applies when the start up current source is on. This is the case when the V_{CC} voltage has not yet reached V_{CCON} or has fallen below V_{CCOFF} .

Thermal Data

Symbol	Parameter	8SOP	8DIP	Unit
R_{THJC}	Thermal resistance junction-case	25	15	$^{\circ}C/W$
R_{THJA}	Thermal resistance ambient-case ^(Note)	55	45	$^{\circ}C/W$

Note: When mounted on a standard single-sided FR4 board with $200mm^2$ of Cu (at least $35\mu m$ thick) connected to all SW pins.

Electrical Characteristics

 Ta=25°C, V_{CC}=18V, unless otherwise specified

Symbol	Parameter	Test Conditions	Min.	Typ.	Max.	Unit
Power Section						
BV _{DSS}	Drain-Source Voltage	I _D =1mA; V _{FB} =2V	730	—	—	V
I _{DSS}	Off State Drain Current	V _{DS} =500V; V _{FB} =2V; T _J =125°C	—	—	0.1	mA
r _{DS(ON)}	Static Drain-Source On State Resistance	I _D =0.2A	—	19	22	Ω
t _F	Fall Time	I _D =0.1A; V _{IN} =300V ⁽¹⁾	—	100	—	nS
t _R	Rise Time	I _D =0.2A; V _{IN} =300V ⁽¹⁾	—	50	—	nS
C _{OSS}	Drain Capacitance	V _{DS} =25V	—	20	—	pF
Supply Section						
I _{CCCH}	Start-Up Charging Current	V _{DS} =100V; V _{CC} =0V to V _{CCON}	—	-1	—	mA
I _{CCOFF}	Start-Up Charging Current In Thermal Shutdown	V _{CC} =5V; V _{DS} =100V T _J > T _{SD} - T _{HYST}	0	—	—	mA
I _{CC}	Operating Supply Current Not Switching	I _{FB} =2mA	—	0.65	0.8	mA
	Operating Supply Current Switching	I _{FB} =0.5mA; I _D =50mA ⁽²⁾	—	0.7	0.9	mA
D _{RST}	Restart Duty-Cycle	—	—	16	—	%
V _{CCOFF}	V _{CC} Under-voltage Shutdown Threshold	—	7	8	9	V
V _{CCON}	V _{CC} Start-Up Threshold	—	13	14.5	16	V
V _{CCHYST}	V _{CC} Threshold Hysteresis	—	5.8	6.5	7.2	V
V _{CCOVP}	V _{CC} Over-voltage Threshold	—	35	38	41	V
Oscillation Section						
f _{OSC}	Oscillator Frequency Total Variation	V _{CC} =V _{CCOFF} to 35V; T _J =0 to 100°C	54	60	66	kHz
PWM Comparator Section						
G _{ID}	I _{FB} to I _D Current Gain	—	—	320	—	—
I _{DLIM}	Peak Current Limitation	V _{FB} =0V	0.32	0.4	0.48	A
I _{FBSD}	I _{FB} Shutdown Current	—	—	0.9	—	mA
R _{FB}	FB Pin Input Impedance	I _D =0mA	—	1.2	—	kΩ
t _D	Current Sense Delay to Turn-Off	I _D =0.2A	—	200	—	nS
t _B	Blanking Time	—	—	350	—	nS
t _{ONMIN}	Minimum Turn-On Time	—	—	550	—	nS
Over-temperature Section						
T _{SD}	Thermal Shutdown Temperature	—	140	170	—	°C
T _{HYST}	Thermal Shutdown Hysteresis	—	—	40	—	°C

Note: Absolute maximum ratings indicate limits beyond which damage to the device may occur. Operating Ratings indicate conditions for which the device is intended to be functional, but do not guarantee specific performance limits. The guaranteed specifications apply only for the test conditions listed.

1. For clamped inductive load
2. These test conditions are obtained with a resistive load which permit the maximum conduction time of the device.

Functional Description

The HT7A6312 is highly functionally integrated device which combines an integrated PWM controller with current mode control and a high voltage power MOSFET on the same silicon chip. The secondary side feedback signal passes through a photo-coupler on the primary side while the output voltage is regulated by the device according to the feedback signal. The device has a small quiescent current and low power consumption when operating in the standby mode. It also has a range of protection features to protect the controller from fault conditions.

High Voltage Start up

The SW pin in the device is a high voltage start up current source. This current source will generate a current which is regulated from a high voltage and which will charge the VCC pin until the UVLO is triggered when an AC voltage is applied on the converter input. When the VCC voltage is larger than the UVLO trigger voltage, the high voltage start up current source will be cut off by UVLO and the device will start operation by switching the power MOSFET on and off.

Feedback

The FB pin determines the device operation. The power MOSFET current will be sensed by the current sensing resistor which is connected between the source terminal of the power MOSFET and the ground terminal. In addition, this sensing resistor also senses the current coming from the FB pin. The voltage across the resistor will be compared to a fixed reference voltage (0.23V). The power MOSFET is turned off when the sensing resistor voltage is larger than 0.23V. The R_{FB} resistor (R_{FB}=100Ω) is used to increase the reliability in the worst working environment as shown below.

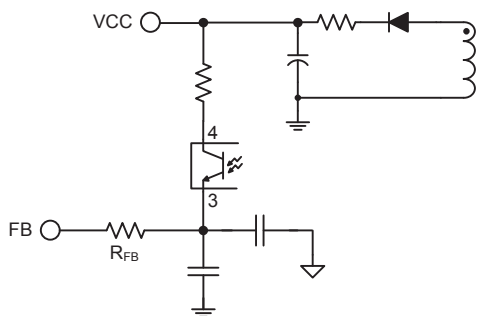

Leading Edge Blanking – LEB

When the power MOSFET is turned on, there is usually a high current spike which is generated by the primary side capacitor and the secondary side rectifier diode reverse recovery. This spike will be sensed by the sensing resistor to indicate an excessive voltage which will in turn lead to false feedback operation in the current mode PWM control circuit. In order to avoid this problem, the device includes a leading edge blanking circuit which inhibits the comparator for a short time after the power MOSFET is turned on.

Under Voltage Lock Out – UVLO

When the fault condition happens, the device will shut down the power MOSFET and cause the V_{CC} voltage to fall. When the V_{CC} voltage is lower than the UVLO lower voltage (8V), the protection circuits will be reset and the internal high voltage start up current source will charge the V_{CC} capacitor. Not until the V_{CC} voltage reaches the UVLO higher voltage (14.5V), the device will resume normal operation. In this way, the auto-restart function can enable and disable the power MOSFET switching alternately until the fault condition is eliminated.

Thermal Shutdown – TSD

Because the device integrates the controller and the power MOSFET on the same chip, the temperature of the device including the power MOSFET can be easily detected. When the temperature is over 170°C, the thermal shutdown protection function will be active to turn off the power MOSFET. The device will resume normal operation when the device temperature is lower than the recovery temperature of about 130°C and when the V_{CC} voltage is lower than 2V.

Over Voltage Protection – OVP

When a malfunction occurs in the secondary side feedback circuit, or if a wiring defect allows the feedback loop to be open, the current through the opto-coupler will be near to zero. At this time, as the excess energy will be supplied to the output, the output voltage may be higher than the regulated voltage and may damage the components in the secondary side. The device includes an over voltage protection function to avoid this condition happening. If the V_{CC} voltage is higher than 38V, the device will be shut down by the OVP protection function to prevent the malfunctions from damaging components.

Application Circuits

Buck Topology

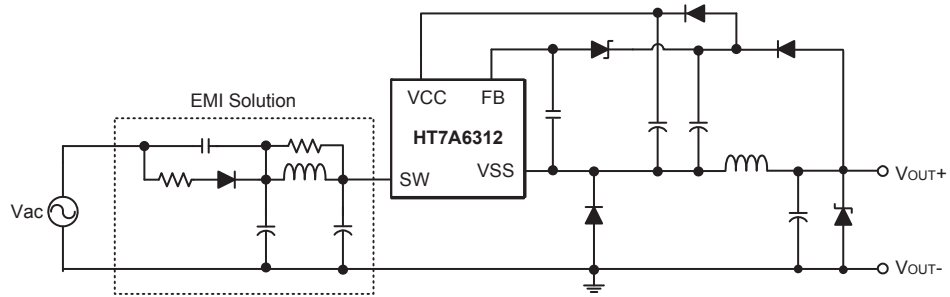

Buck - Boost Topology

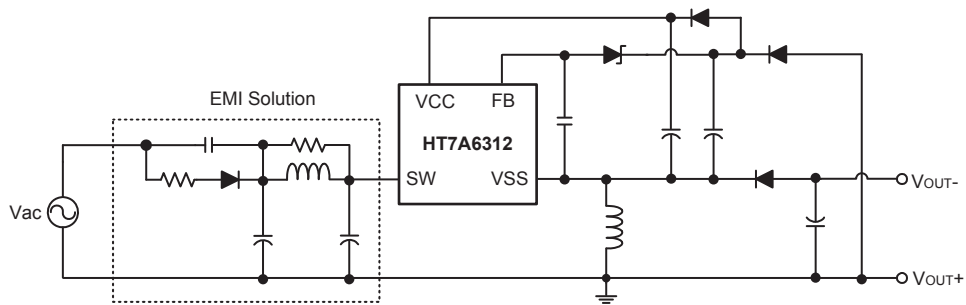

Non-Isolation Flyback Topology

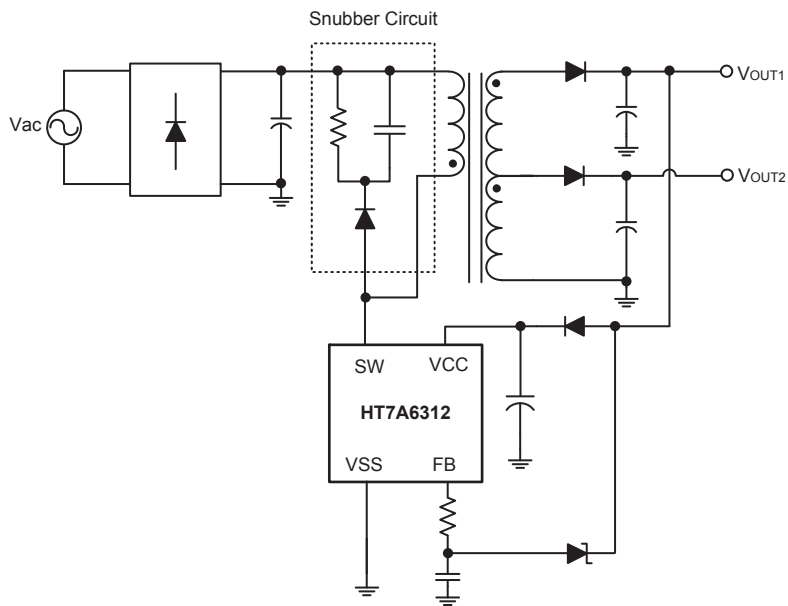

Package Information

Note that the package information provided here is for consultation purposes only. As this information may be updated at regular intervals users are reminded to consult the [Holtek website](#) for the latest version of the [Package/ Carton Information](#).

Additional supplementary information with regard to packaging is listed below. Click on the relevant section to be transferred to the relevant website page.

- Package Information (include Outline Dimensions, Product Tape and Reel Specifications)
- The Operation Instruction of Packing Materials
- Carton information

8-pin DIP (300mil) Outline Dimensions

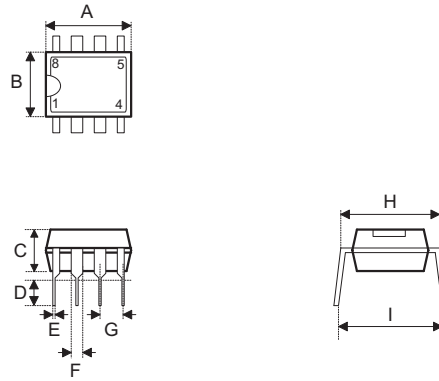

Symbol	Dimensions in inch		
	Min.	Nom.	Max.
A	0.355	0.365	0.400
B	0.240	0.250	0.280
C	0.115	0.130	0.195
D	0.115	0.130	0.150
E	0.014	0.018	0.022
F	0.045	0.060	0.070
G	—	0.100 BSC	—
H	0.300	0.310	0.325
I	—	—	0.430

Symbol	Dimensions in mm		
	Min.	Nom.	Max.
A	9.02	9.27	10.16
B	6.10	6.35	7.11
C	2.92	3.30	4.95
D	2.92	3.30	3.81
E	0.36	0.46	0.56
F	1.14	1.52	1.78
G	—	2.54 BSC	—
H	7.26	7.87	8.26
I	—	—	10.92

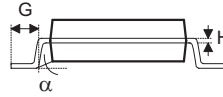
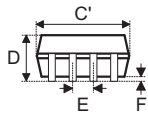
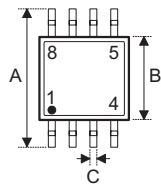
8-pin SOP (150mil) Outline Dimensions

Symbol	Dimensions in inch		
	Min.	Nom.	Max.
A	—	0.236 BSC	—
B	—	0.154 BSC	—
C	0.012	—	0.020
C'	—	0.193 BSC	—
D	—	—	0.069
E	—	0.050 BSC	—
F	0.004	—	0.010
G	0.016	—	0.050
H	0.004	—	0.010
α	0°	—	8°

Symbol	Dimensions in mm		
	Min.	Nom.	Max.
A	—	6.00 BSC	—
B	—	3.90 BSC	—
C	0.31	—	0.51
C'	—	4.90 BSC	—
D	—	—	1.75
E	—	1.27 BSC	—
F	0.10	—	0.25
G	0.40	—	1.27
H	0.10	—	0.25
α	0°	—	8°

Copyright© 2018 by HOLTEK SEMICONDUCTOR INC.

The information appearing in this Data Sheet is believed to be accurate at the time of publication. However, Holtek assumes no responsibility arising from the use of the specifications described. The applications mentioned herein are used solely for the purpose of illustration and Holtek makes no warranty or representation that such applications will be suitable without further modification, nor recommends the use of its products for application that may present a risk to human life due to malfunction or otherwise. Holtek's products are not authorized for use as critical components in life support devices or systems. Holtek reserves the right to alter its products without prior notification. For the most up-to-date information, please visit our web site at <http://www.holtek.com.tw>.