

### Features

- 1.8V to 6V Single Supply
- Output Power:
  - 3W/channel at 5V and 4Ω speaker
  - 4.45W/channel at 6V and, 4Ω speaker
- Up to 90% power efficiency
- Automatic output power control – APC
- 2.8mA quiescent current at 5V
- Less than 0.2μA shutdown current
- Pop noise elimination during power on/off
- Mute and Shutdown function
- Output pin short circuit protection with auto recovery
- Over-temperature and over-current protection with auto recovery
- Integrated hard limiter function
- Limiter time and gain control on the fly
- Differential 250kHz PWM allows Bridge-Tied-Load to increase output power and eliminate LC output filter
- Differential signal processing for improved CMRR
- 20-pin TSSOP-EP package

### Applications

- Portable audio products
- Battery powered audio products
- MP3 players
- Bluetooth speakers
- Notebook/Tablet PCs
- Smartphones

### Description

The HT82V7534 is a filter-less stereo Class D audio power amplifier IC. The device can deliver up to 3 watts per channel into a 4Ω load at a 5V operating voltage. The advantage of using class D amplifiers is that they offer superior efficiency over the traditional linear amplifiers. This advantage results in less heat generation thus eliminating the need for heat sinking making them ideal for use in small outline products.

One special feature of the device is its ability to operate over a wide voltage range, from 1.8V to 6V. Additional features include automatic power level control, wherein the output power remains consistent for different voltages. A function to reduce the annoying "pop" sound which could be generated during power on/off operations is also included. The device contains a range of protection features, such as output short circuit protection, over current/thermal shutoff and auto recovery functions which restores the device to normal operation once the source of the problem has been resolved.

The superior efficiency of this Holtek class D audio amplifier together with its wide operating voltage and ability to directly drive speakers make it excellent for use in compact portable battery operated equipment where battery life will be an important consideration.

### Block Diagram

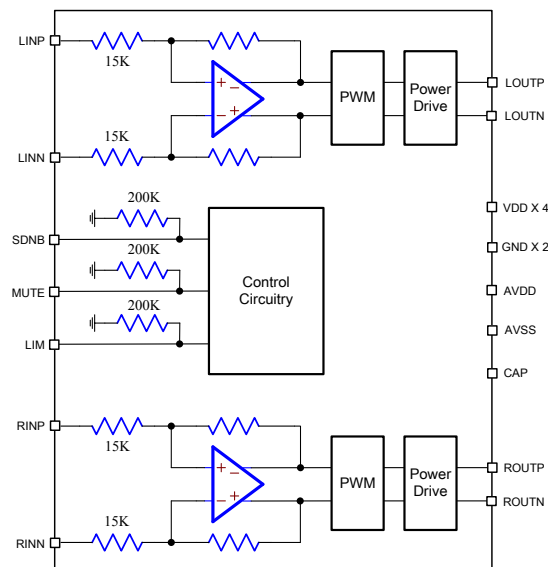

## Pin Assignment

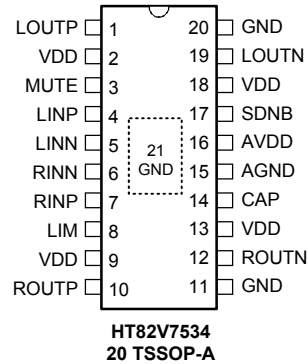

## Pin Description

Pin Number	Pin Name	Type	Description
1	LOUDP	AO	Left Channel Positive Output
2	VDD	PWR	Digital Power Supply
3	MUTE	DI	Audio Mute Function – active high
4	LINP	AI	Left Channel Positive Differential Input
5	LINN	AI	Left Channel Negative Differential Input
6	RINN	AI	Right Channel Negative Differential Input
7	RINP	AI	Right Channel Positive Differential Input
8	LIM	DI	Limiter Enable – active high
9	VDD	PWR	Digital Power Supply
10	ROUDP	AO	Right Channel Positive Output
11	GND	PWR	Digital Ground
12	ROUTN	AO	Right Channel Negative Output
13	VDD	PWR	Digital Power Supply
14	CAP	AO	Limiter Operation Capacitor
15	AGND	PWR	Analog Ground
16	AVDD	PWR	Analog Power Supply
17	SDNB	DI	Shutdown Control – active low
18	VDD	PWR	Digital Power Supply
19	LOUDN	AO	Left Channel Negative Output
20	GND	PWR	Digital Ground
21	GND	PWR	Exposed Ground Pad

\*\* AO: Analog Output; AI: Analog Input; DI: Digital Input; PWR: Power Pin

## Absolute Maximum Ratings

Supply Voltage .....	$V_{SS}-0.3V$ to $6.5V$	Input Voltage.....	$V_{SS}-0.3V$ to $V_{DD}+0.3V$
Storage Temperature .....	$-50^{\circ}C$ to $125^{\circ}C$	Operating Temperature.....	$-40^{\circ}C$ to $85^{\circ}C$

Note: These are stress ratings only. Stresses exceeding the range specified under "Absolute Maximum Ratings" may cause substantial damage to the device. Functional operation of this device at other conditions beyond those listed in the specification is not implied and prolonged exposure to extreme conditions may affect device reliability.

## Package Dissipation Ratings

Package	Derating Factor	T <sub>A</sub> ≤25°C Power Rating	T <sub>A</sub> =70°C Power Rating	T <sub>A</sub> =85°C Power Rating
TSSOP20	26mW/°C	3.25W	2.08W	1.69W

## DC Characteristics

V<sub>DD</sub>=AV<sub>DD</sub>=2.5V-6.0V, T<sub>A</sub>=25°C, (unless otherwise noted)

Symbol	Parameter	Test Conditions		Min.	Typ.	Max.	Unit
		V <sub>DD</sub>	Conditions				
V <sub>DD</sub> /AV <sub>DD</sub>	Supply Voltage	—	—	1.8	—	6.0	V
I <sub>Q</sub>	Quiescent Current Per Channel	5V	No load	—	2.8	3.2	mA
		3.6V		—	2.2	2.6	mA
		2V		—	1.1	1.5	mA
I <sub>STB</sub>	Standby Current	—	SDNB=0.5V	—	0.2	0.5	μA
V <sub>IH</sub>	SDNB, MUTE, LIM High Level Logic Level	5V	—	2.0	—	V <sub>DD</sub>	V
V <sub>IL</sub>	SDNB, MUTE, LIM Low Level Logic Level	5V	—	0	—	0.8	V
I <sub>IH</sub>	SDNB, MUTE, LIM High-level Input Current	5V	SDNB/MUTE/LIM=5V	—	—	30	μA
I <sub>IL</sub>	SDNB, MUTE, LIM Low-level Input Current	5V	SDNB/MUTE/LIM=0V	—	—	1	μA
V <sub>OS</sub>	Differential Output Offset Voltage	—	All inputs are AC grounded, AV=25	—	±25	—	mV
R <sub>DSON</sub>	Static drain-source on-state Resistance	5V	R <sub>L</sub> =8Ω	—	400	—	mΩ
R <sub>IN</sub>	RINN/RINP/LINN/LINP Input Resistance	—	RINN/RINP/LINN/LINP=0V	—	15	—	kΩ
R <sub>SDNB</sub>	SDNB/MUTE/LIM Input Resistance	—	SDNB/MUTE/LIM=0V	—	200	—	kΩ
A <sub>V</sub>	BTL Gain	—	R <sub>L</sub> =8Ω	—	25	—	V/V
I <sub>OC</sub>	Over-current Protection Threshold	V <sub>DD</sub> =AV <sub>DD</sub> =5V	Vo+ shorted to VDD	—	2.5	—	A
			Vo- shorted to VDD	—	2.5	—	
			Vo+ shorted to GND	—	1.4	—	
			Vo- shorted to GND	—	1.4	—	
			Vo+ shorted to Vo-	—	1.8	—	
TAR	Over-current Detection Time (Time from Overcurrent Detected to Retrial)	V <sub>DD</sub> =AV <sub>DD</sub> =5V	Vo+/Vo- shorted to VDD/GND, Vo+ shorted to Vo-	—	16	—	mS
I <sub>Q(OC)</sub>	Supply Current under Over-current Protection			—	2	—	mA
T <sub>A</sub>	Operating Temperature	—	—	-40	—	85	°C

## AC Characteristics

 $V_{DD}=AV_{DD}=2.5V-6.0V$ ,  $T_A=25^{\circ}C$ , (unless otherwise noted)

Symbol	Parameter	Test Conditions	Min.	Typ.	Max.	Unit
LIM	THD (%) of Limiter Enable Point	$V_{DD}=3.6V-6.0V$	—	1	—	%
$f_{sw}$	Switching Frequency		200	250	300	kHz
PSRR	Common Mode Rejection Ratio		—	-70	—	dB
SNR	Signal-to-noise Ratio	$P_o=1W$ , $R_L=8\Omega$	—	100	—	dB
CMRR	Common Mode Rejection Ratio	$V_{ic}=1V_{pp}$ , $R_L=8\Omega$	—	-70	—	dB

Note: When supply voltage is below 2.2V and 4Ω speaker is used, the protection will be triggered if total harmonic distortion of the output is greater than 1%, To prevent this protection from happening an 8Ω speaker should be used instead.

## Operating Characteristics

 $V_{DD}=AV_{DD}=5V$ , Power Supply Capacitance=470μF,  $T_A=25^{\circ}C$ , (unless otherwise noted)

Symbol	Parameter	Test Conditions		Min.	Typ.	Max.	Unit	
		$V_{DD}$	Conditions					
$P_o$	Output Power	3.6V	THD=1%	4Ω	—	1.04	—	W
				8Ω	—	0.7	—	
			THD=10%	4Ω	—	1.55	—	
				8Ω	—	0.88	—	
		5.0V	THD=1%	4Ω	—	2.44	—	
				8Ω	—	1.39	—	
			THD=10%	4Ω	—	3.02	—	
				8Ω	—	1.72	—	
		5.5V	THD=1%	4Ω	—	2.98	—	
				8Ω	—	1.69	—	
			THD=10%	4Ω	—	3.67	—	
				8Ω	—	2.09	—	
6.0V	THD=1%	4Ω	—	3.02	—			
		8Ω	—	1.73	—			
	THD=10%	4Ω	—	4.45	—			
		8Ω	—	2.53	—			

### Typical Performance Characteristic

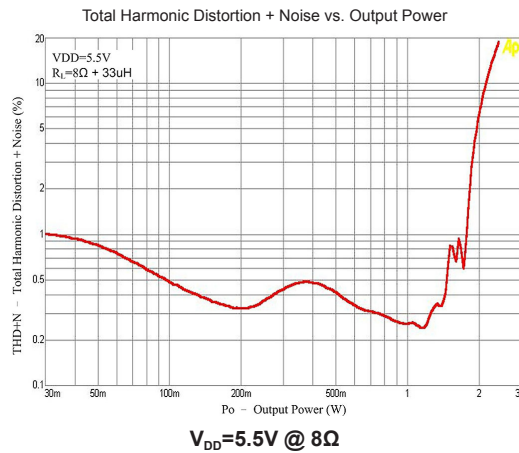
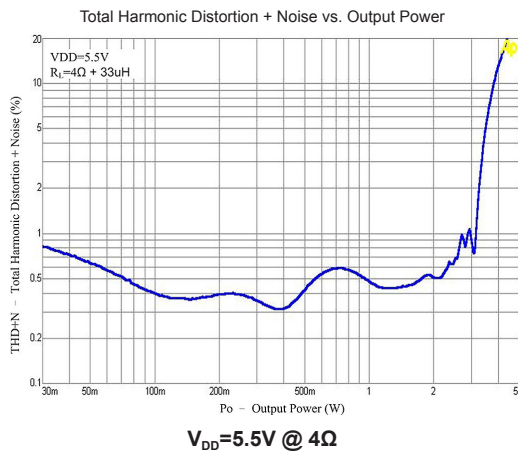
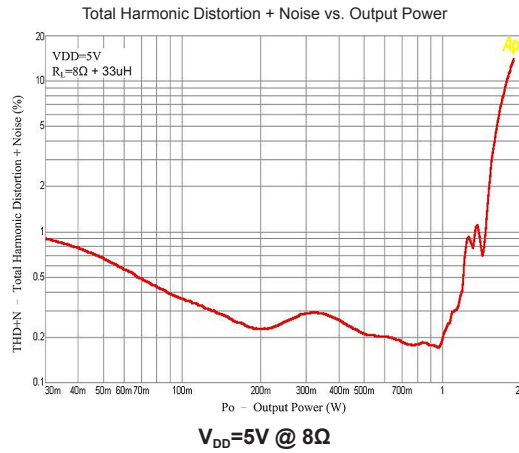
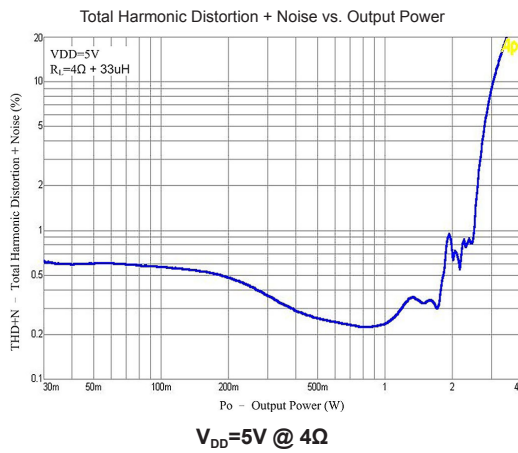
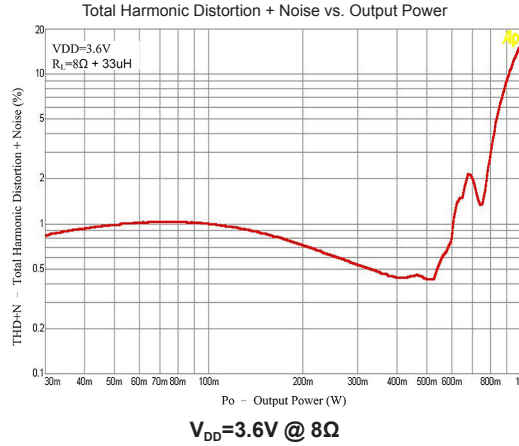
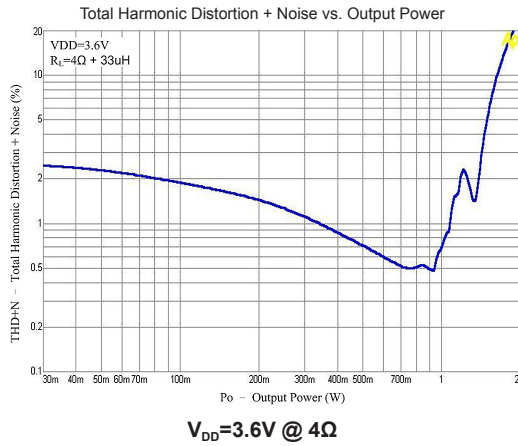

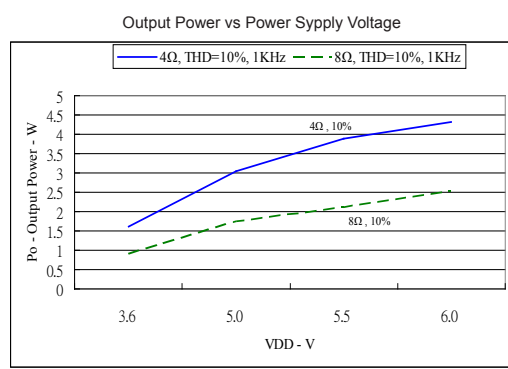
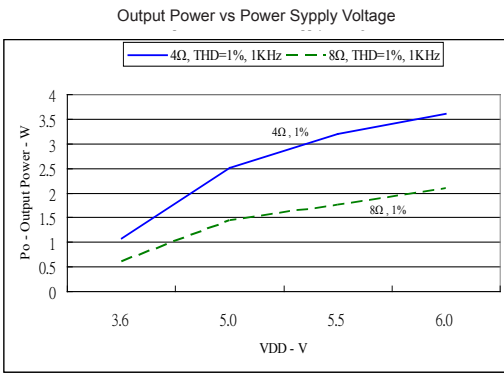
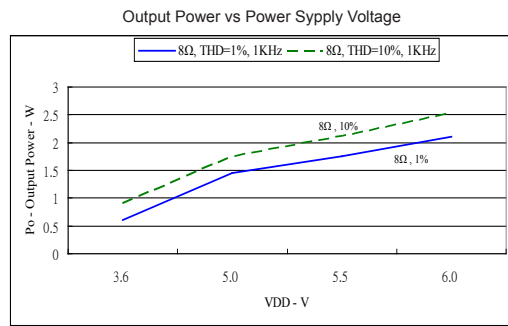
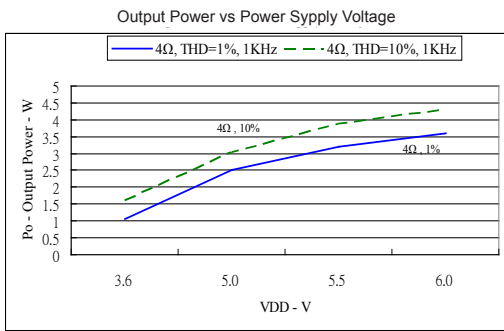
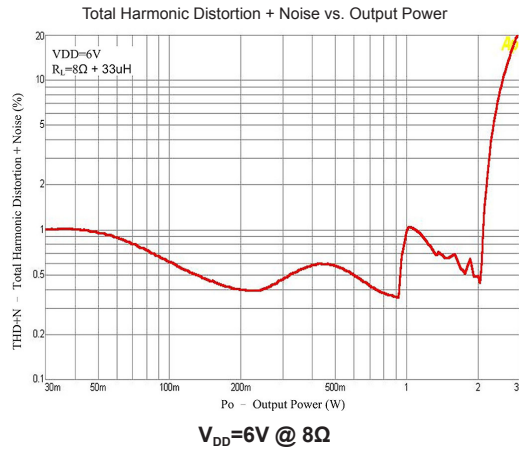
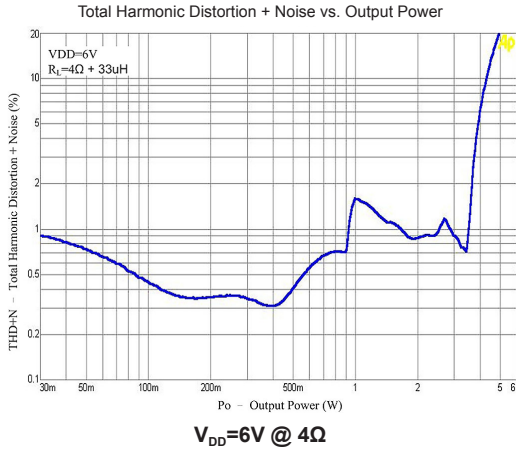

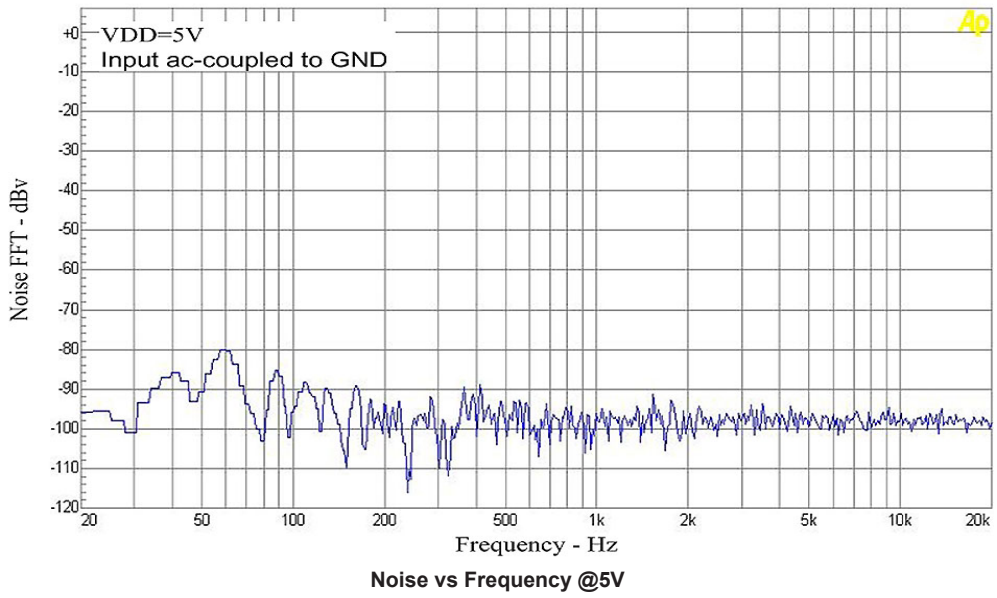
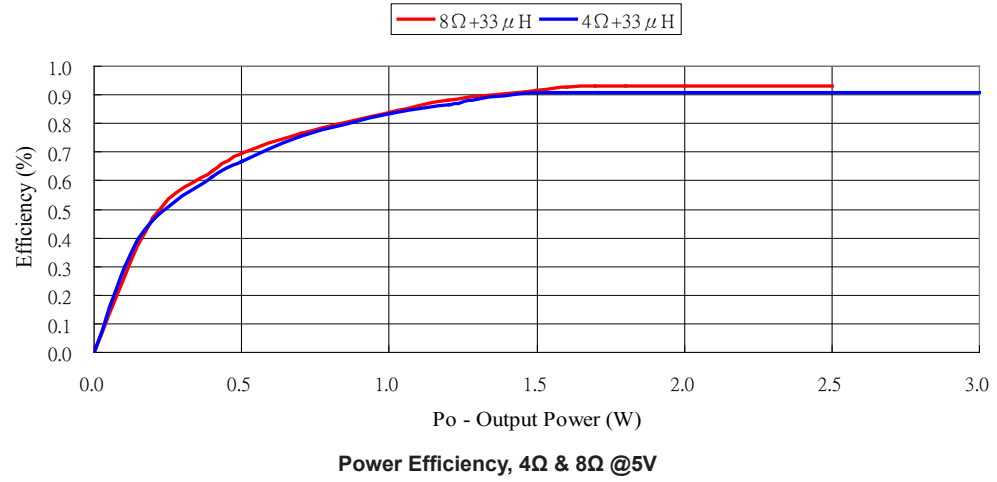

## Functional Description

The HT82V7534 is a Class D type stereo audio amplifier. Offering the advantages of fully digital operation this Class D audio amplifier has the advantages of low power losses resulting in higher efficiencies and reducing the need for heat sinking. Power down and Mute functions along with several protection features provide a highly functionally integrated audio amplifier solution.

### Amplifier Input Stage

Looking into any of the audio pins will see a resistance of 15KΩ. The following diagram shows a typical input stage circuit.

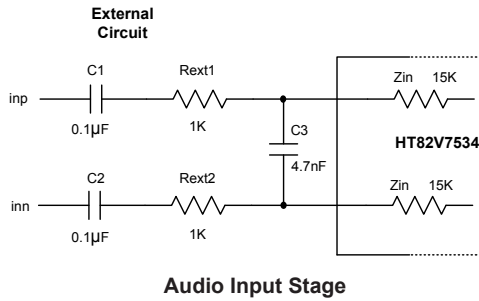

Here external resistors have been connected between the amplifier audio inputs and the external audio signal source to setup the gain value. As the external signal needs to be ac coupled to the amplifier using capacitors this will form a high pass filter with these resistors. The -3db frequency of this input high pass filter will be given by.

$$f_{-3db} = 1 / (2\pi RC) \quad (1)$$

Where C is the ac coupling capacitance, C1 or C2, and R is the total resistance in series with the capacitor. So here C=0.1µF and R=Zin + Rext, in the example of the diagram which gives a value of 1K + 15K. Putting these numbers into the above equation gives a -3db frequency of about 100Hz. A bypass capacitor, C3, is also connected across the input pins to attenuate any high frequencies. This capacitor will form a low pass filter with the resistors. In this example Rext=1KΩ, Zin=15K and C=4.7nF. Thus the - 3db frequency on the high frequency side is about 18kHz.

It is important to ensure that any external input pin related components are well matched. Not ensuring good matching of these differential input components may create an annoying pop noise during operation.

### Low Voltage Detection

A power supply voltage monitoring circuit is integrated into the device. Should the supply voltage fall below a value of about 1.7V then the outputs will be disabled. When the supply voltage is maintained above 1.8V then the device will operate normally.

### Pop-Free

The device includes a pop-free function. However to fully eliminate any annoying "pop" sounds being generated when the device is powered on or off, switching in the mute mode, switching in the shutdown mode, recovery from temperature protection or recovery from over-current protection it is important to ensure that the differential inputs are fully balanced.

### Automatic Output Power Control – APC

The voltage gain of the amplifier will automatically adjust itself over the full voltage range. This means that, regardless of changes to the supply voltage, the output power will remain at approximately the same level for a given input level for a supply voltage range of 2.5v to 6.0v. This feature could be important in battery powered applications where the supply voltage will drop as the batteries lose their charge.

### Amplifier Gain

The voltage gain of the amplifier is determined by a resistance ratio. The formula for calculating the voltage gain over the supply voltage range of VDD=AVDD=2.5V to 6.0V, is given by the following formula:

$$A_v = \frac{375K}{15K + R_{ext}} \quad (2)$$

Where Rext is the external series resistance at the input pin which can be seen in the application circuits. Note that these gain setting external resistors must be well matched to avoid the creation of any pop noise during operation.



### Shutdown Function – SDNB

The device can be shut down to conserve power during times when the audio output function of the product is not required. The shutdown function is executed by pulling the SDNB pin low. When the SDNB pin is high the device will operate normally. There is an internal pull down resistor of 200KΩ between the SDNB pin and ground.

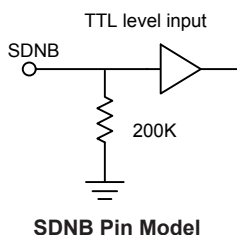

### Mute Function – MUTE

The device includes a mute function which will disable any output signal generation but while still keeping the device active with a PWM duty cycle of 50%. The mute function is executed by pulling the MUTE pin high. When the MUTE pin is low the audio output will operate normally. There is an internal pull down resistor of 200KΩ between the MUTE pin and ground.

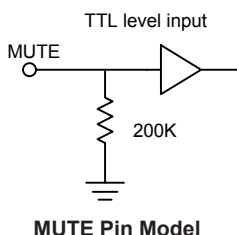

### Hard Limiter and Control – LIM

The device includes a hard limiter function. The hard limiter detects the THD of the output signals and if it is below approximately 1% takes no action. However should the THD of the output signal be above 1% the hard limiter will immediately reduce the magnitude of the output signal by 6dB. This prevents the output signals from being clipped, avoiding the generation of high order harmonic signals which create unpleasant distorted sound effects. The hard limiter function is enabled by pulling the LIM pin high. Keeping the LIM pin low will disable the limiter. When the limiter is disabled the amplifier will have a fixed gain as described elsewhere. There is an internal pull down resistor of 200KΩ between the LIM pin and ground.

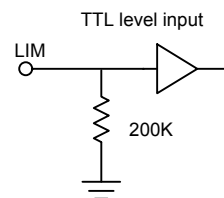

LIM Pin Model

This audio signal magnitude reduction will be maintained for a certain period of time which is determined by the size of an external capacitor connected to the CAP pin. After this time period has elapsed the output audio signal will return to its normal magnitude. For a capacitor value of 0.22uF, the magnitude reduction time period is 8.5 seconds. This time period changes with the capacitor value in a linear manner. Therefore for a capacitor value of 0.1uF the time period will be 3.8 seconds. An internal current source is connected to the CAP pin which charges the external capacitor in a linear manner.

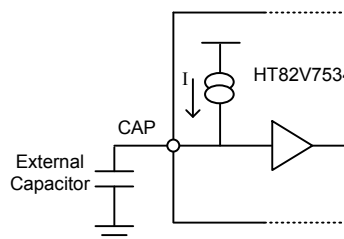

CAP Pin Configuration

An external control signal connected to the CAP pin can be used as a gain control signal as it can overwrite the limiter operation and behave like a gain control. If an external control signal is connected to the CAP pin, then when this signal is high, the amplifier will maintain its normal gain setting. However driving this pin low will force the amplifier to have a reduced gain down to 6dB from the original value. The voltage gain can be changed on the fly and there is no delay when the control signal switches in between the low and high values.

### Differential Input versus Single Ended Input

Using a differential input type will result in better noise immunity over a single ended input. The common mode rejection characteristics of the device's internal differential input amplifier will reject any noise which appears on both pins and will only amplify the differential audio signal on the input pins. If a single ended input structure is required, then the negative input should be connected to ground. If external series input resistors are used, then the negative input has to be grounded using a series resistor of the same value as the positive input to keep the input stage balanced to reduce common mode noise

### EMI and LC Output Filter Design

To reduce EMI interference ferrite bead filters can be used. A ferrite filter will reduce EMI frequencies of around 1 MHz and higher. Note that FCC and CE only test radiated emissions greater than 30 MHz. When selecting a ferrite bead, choose one with a high impedance at high frequencies but with a low impedance at low frequencies or high impedance at the interfering frequencies.

Use an LC output filter if there are any low frequency (< 1 MHz) EMI sensitive circuits and if there are any long wires from the amplifier to the speaker. Note that EMI is also affected by PCB layout and the placement of the surrounding components therefore care must be taken in this regard.

The suggested LC configuration for EMI filters are shown as follows.

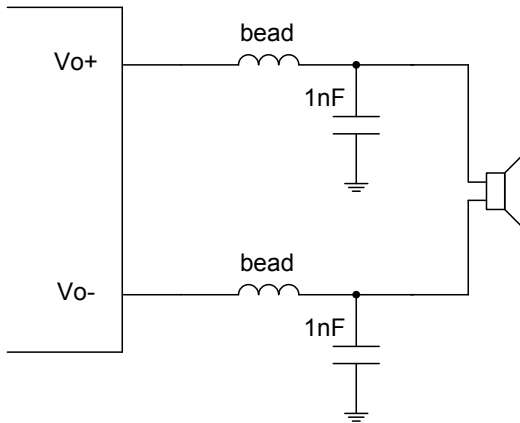

Filter-less BTL Output Configuration – 1

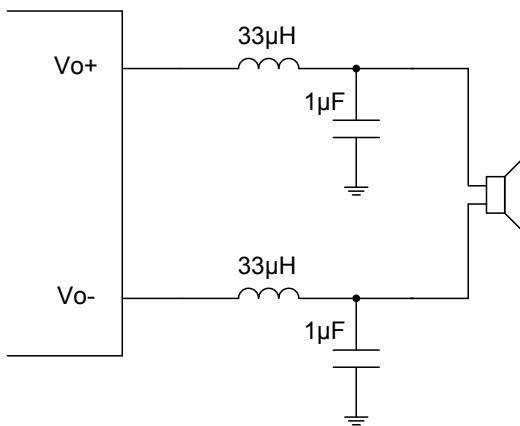

Typical BTL Output LC Filter – 2

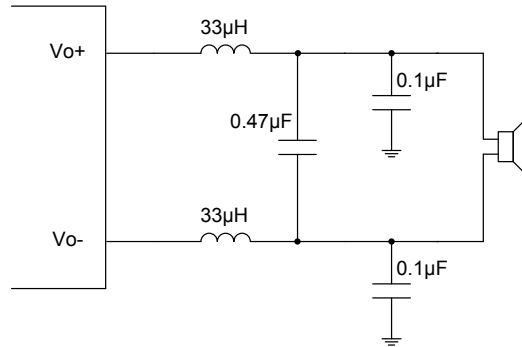

Typical BTL Output LC Filter – 3

### Over Temperature Protection

The device includes an integrated temperature sensor. When this detects an internal temperature about 120°C or above, the output signals will be disabled to protect the device from any damage. An automatic recovery circuit enables the device to return to normal operation when the internal temperature of the device returns to below around 100°C.

### Over Current Protection

A current detection circuit is integrated into the device to detect the switching current of the output stages of the device. It disables the device when the current is beyond the current limits specified in the operating characteristics. This protects the device when there is an accidental short circuit between the outputs or between the output pins and power/ground pins. An automatic recovery circuit returns the device to normal operation when the problem source is removed. The delay time between protection and recovery is about 16ms. If the short circuit condition is not removed the after auto-recovery time the protection circuit will disable the output transistors again. The protection circuit will switch the output transistors on and off until the source of the short circuit condition is removed.

## Application Circuits

### Differential Input Configuration

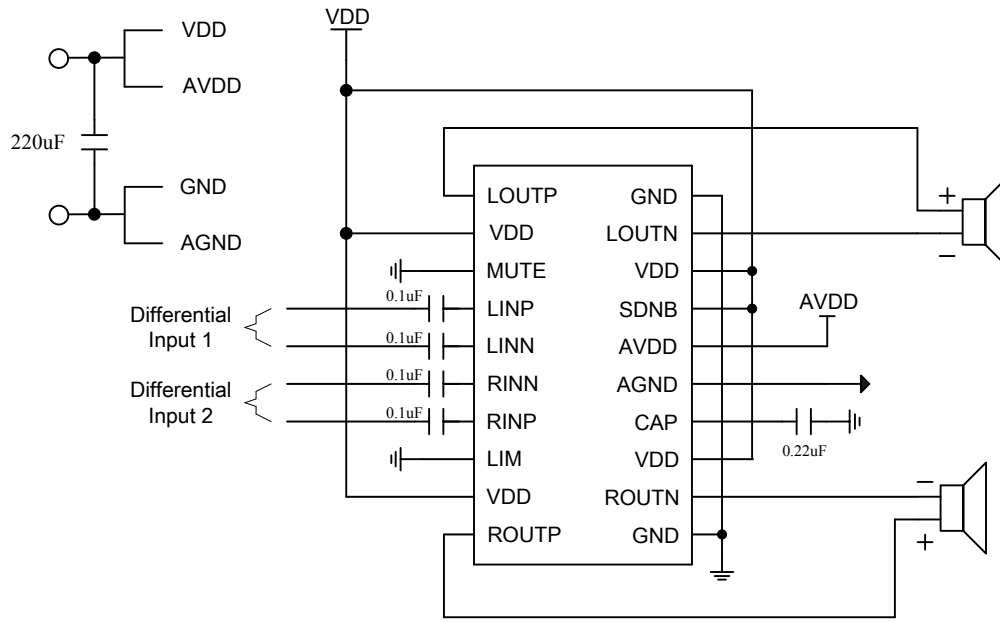

Differential Input Application

### Single Ended Input Configuration

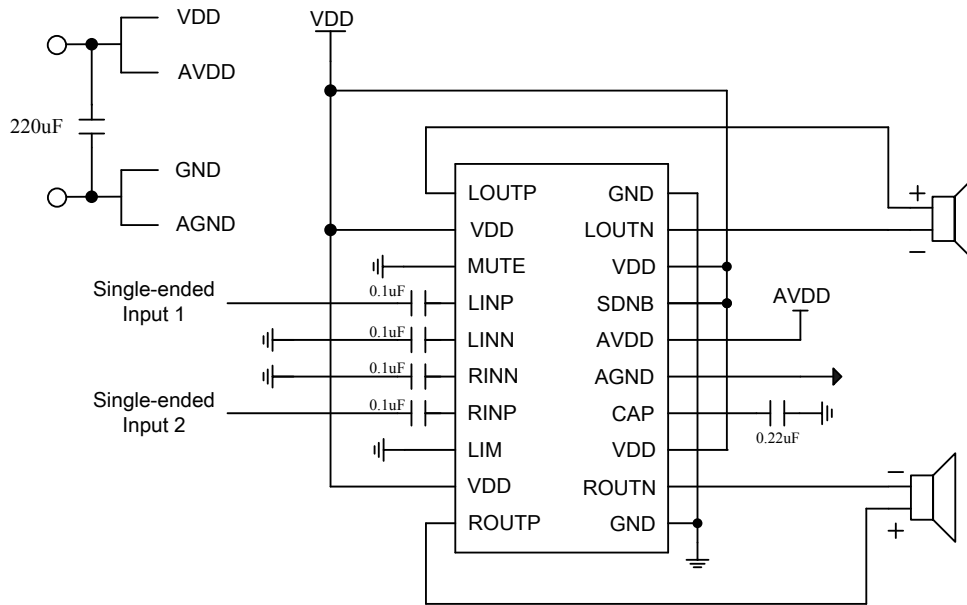

Single Ended Input Application

Differential Input with Gain=375K/(15K+Ri)

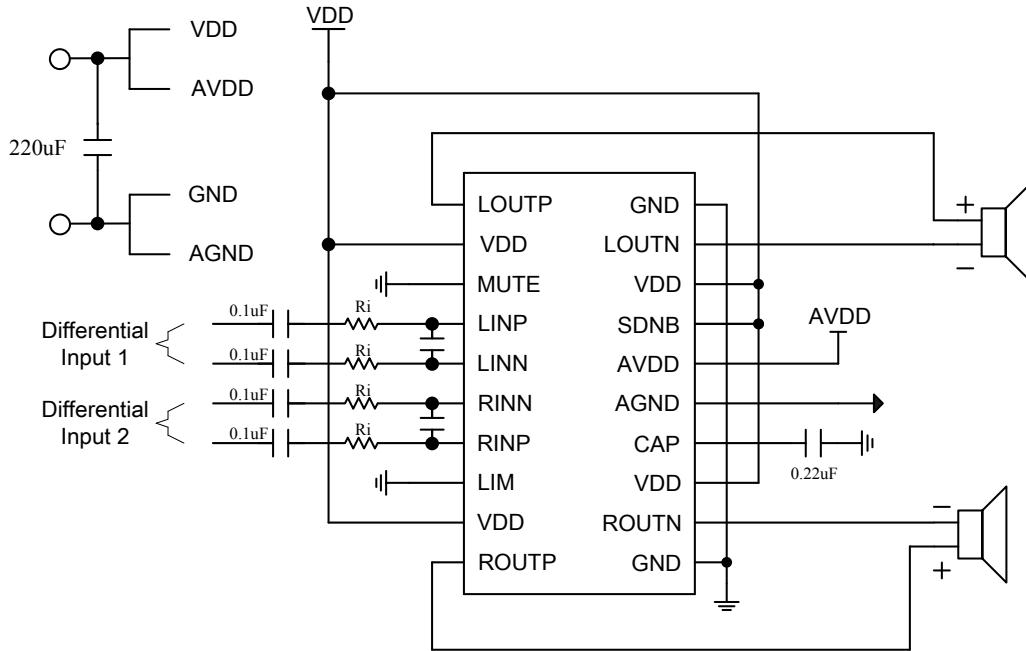

Differential Input with Fixed R<sub>EXT</sub> Gain Control Application

Differential Input with Gain Control

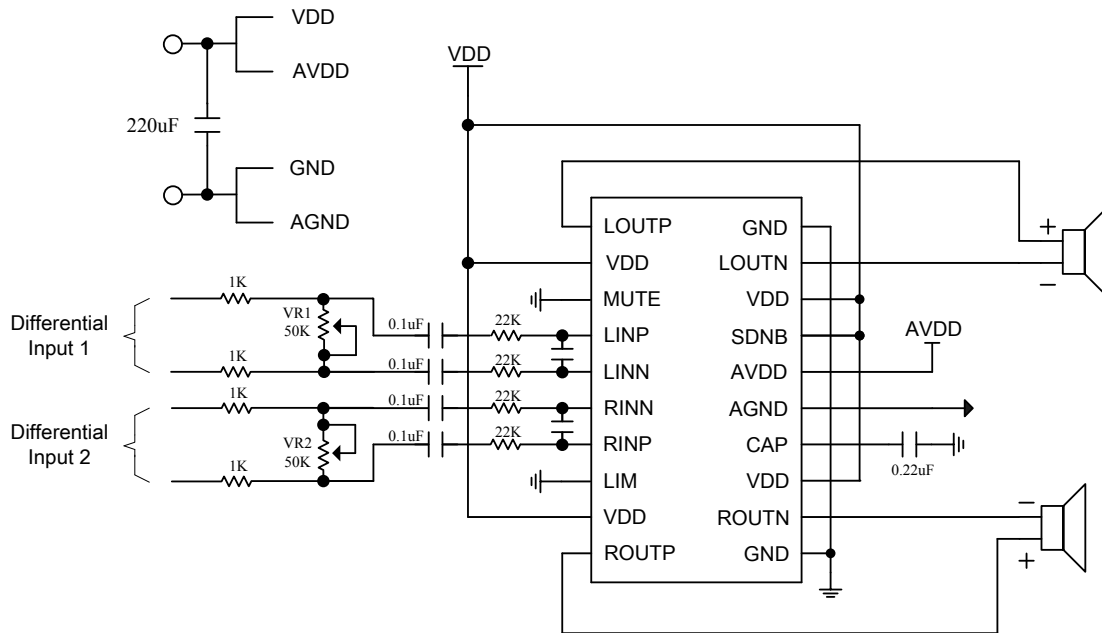

Differential Input with Adjustable Gain Control Application

Single Ended Input with Gain Control

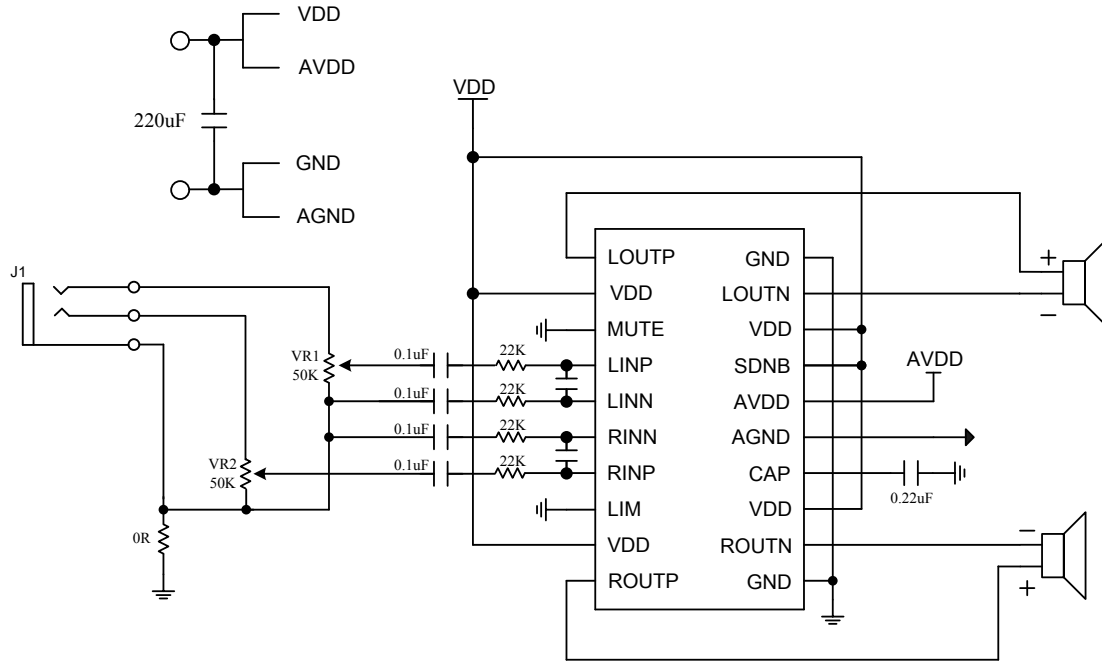

Single Ended Input with Fixed  $R_{EXT}$  Gain Control Application

## Package Information

Note that the package information provided here is for consultation purposes only. As this information may be updated at regular intervals users are reminded to consult the [Holtek website](#) for the latest version of the [Package/Carton Information](#).

Additional supplementary information with regard to packaging is listed below. Click on the relevant section to be transferred to the relevant website page.

- Further Package Information (include Outline Dimensions, Product Tape and Reel Specifications)
- Packing Materials Information
- Carton information

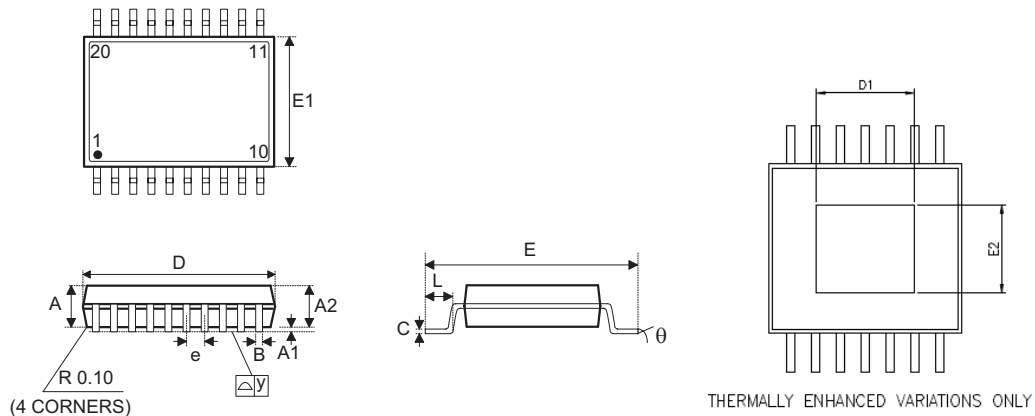
**20-pin TSSOP Outline Dimensions (Exposed Pad)**

Symbol	Dimensions in inch		
	Min.	Nom.	Max.
A	—	—	0.047
A1	0.002	—	0.006
A2	0.031	0.039	0.041
B	0.007	—	0.012
C	0.004	—	0.006
D	0.252	0.256	0.260
D1	0.087	—	—
E	—	0.252 BSC	—
E1	0.169	0.173	0.177
E2	0.059	—	—
e	—	0.026 BSC	—
L	0.018	0.024	0.030
L1	—	0.039 BSC	—
y	—	0.004	—
θ	0°	—	8°

Symbol	Dimensions in mm		
	Min.	Nom.	Max.
A	—	—	1.20
A1	0.05	—	0.15
A2	0.80	1.00	1.05
B	0.19	—	0.30
C	0.09	—	0.16
D	6.40	6.50	6.60
D1	2.20	—	—
E	—	6.40 BSC	—
E1	4.30	4.40	4.50
E2	1.50	—	—
e	—	0.65 BSC	—
L	0.45	0.60	0.75
L1	—	1.0 BSC	—
y	—	0.10	—
θ	0°	—	8°

Copyright© 2016 by HOLTEK SEMICONDUCTOR INC.

The information appearing in this Data Sheet is believed to be accurate at the time of publication. However, Holtek assumes no responsibility arising from the use of the specifications described. The applications mentioned herein are used solely for the purpose of illustration and Holtek makes no warranty or representation that such applications will be suitable without further modification, nor recommends the use of its products for application that may present a risk to human life due to malfunction or otherwise. Holtek's products are not authorized for use as critical components in life support devices or systems. Holtek reserves the right to alter its products without prior notification. For the most up-to-date information, please visit our web site at <http://www.holtek.com.tw>.