

## Remote 8-bit I/O expander for I<sup>2</sup>C-bus

### 1 FEATURES

- Operating supply voltage 2.5 to 6 V
- Low standby current consumption of 10  $\mu$ A maximum
- I<sup>2</sup>C-bus to parallel port expander
- Open-drain interrupt output
- 8-bit remote I/O port for the I<sup>2</sup>C-bus
- Compatible with most microcontrollers
- Latched outputs with high current drive capability for directly driving LEDs
- Address by 3 hardware address pins for use of up to 8 devices (up to 16 with HT8574A)
- DIP16, or space-saving SO16 or SSOP20 packages.

The device consists of an 8-bit quasi-bidirectional port and an I<sup>2</sup>C-bus interface. The HT8574B has a low current consumption and includes latched outputs with high current drive capability for directly driving LEDs. It also possesses an interrupt line ( $\overline{\text{INT}}$ ) which can be connected to the interrupt logic of the microcontroller. By sending an interrupt signal on this line, the remote I/O can inform the microcontroller if there is incoming data on its ports without having to communicate via the I<sup>2</sup>C-bus. This means that the HT8574B can remain a simple slave device.

The HT8574B and HT8574A versions differ only in their slave address as shown in Fig.10.

### 2 GENERAL DESCRIPTION

The HT8574B is a silicon CMOS circuit. It provides general purpose remote I/O expansion for most microcontroller families via the two-line bidirectional bus (I<sup>2</sup>C-bus).

### 3 ORDERING INFORMATION

TYPE NUMBER	PACKAGE		
	NAME	DESCRIPTION	VERSION
HT8574BNZ; HT8574ANZ	DIP16	plastic dual in-line package; 16 leads (300 mil)	SOT38-4
HT8574BRWZ; HT8574ARWZ	SO16	plastic small outline package; 16 leads; body width 7.5 mm	SOT162-1
HT8574BRTZ HT8574ARTZ	SSOP20	plastic shrink small outline package; 20 leads; body width 4.4 mm	SOT266-1

4 BLOCK DIAGRAM

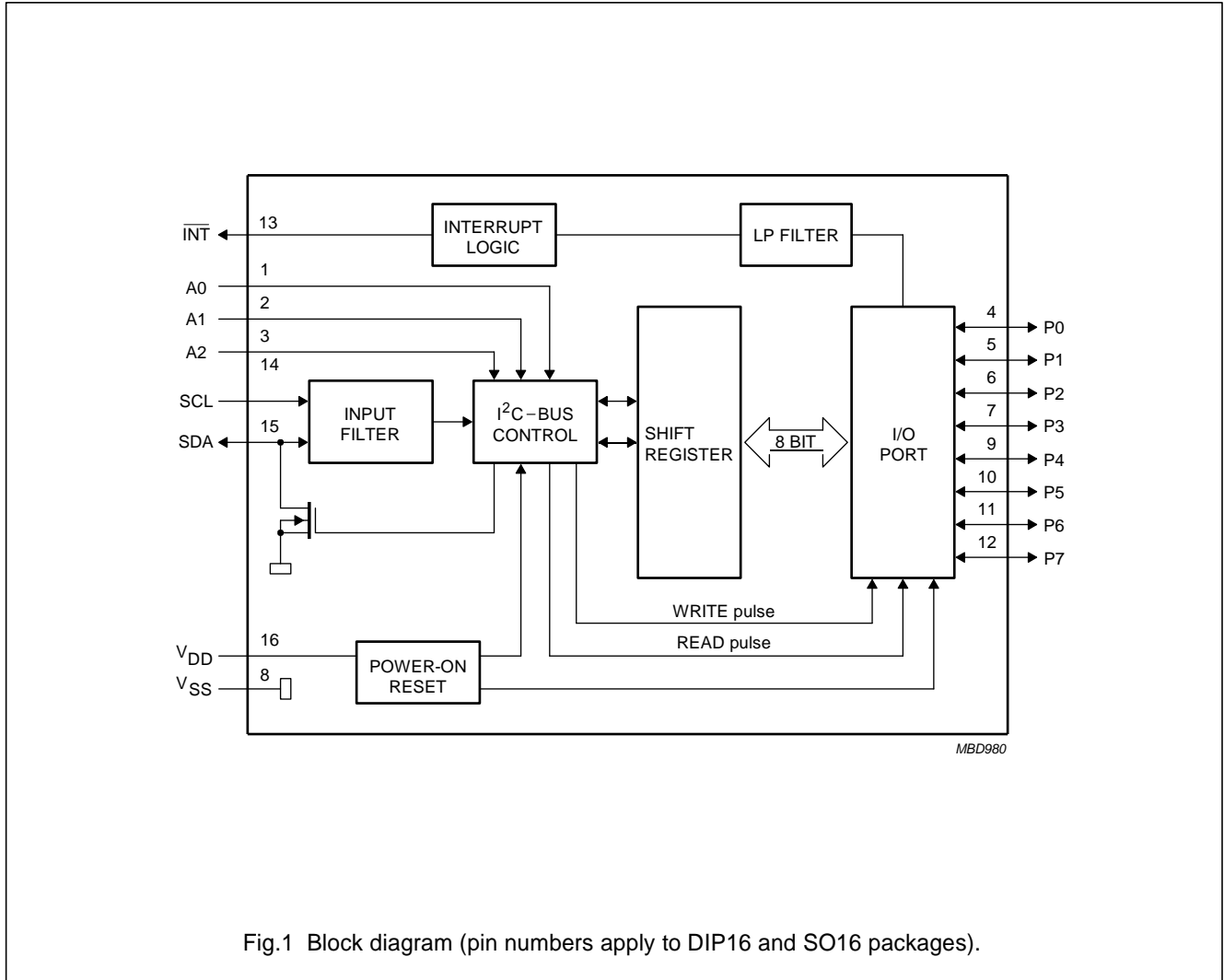

Fig.1 Block diagram (pin numbers apply to DIP16 and SO16 packages).

**5 PINNING**
**5.1 DIP16 and SO16 packages**

SYMBOL	PIN	DESCRIPTION
A0	1	address input 0
A1	2	address input 1
A2	3	address input 2
P0	4	quasi-bidirectional I/O 0
P1	5	quasi-bidirectional I/O 1
P2	6	quasi-bidirectional I/O 2
P3	7	quasi-bidirectional I/O 3
V <sub>SS</sub>	8	supply ground
P4	9	quasi-bidirectional I/O 4
P5	10	quasi-bidirectional I/O 5
P6	11	quasi-bidirectional I/O 6
P7	12	quasi-bidirectional I/O 7
INT	13	interrupt output (active LOW)
SCL	14	serial clock line
SDA	15	serial data line
V <sub>DD</sub>	16	supply voltage

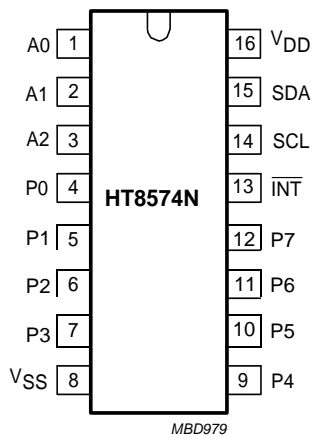

Fig.2 Pin configuration (DIP16).

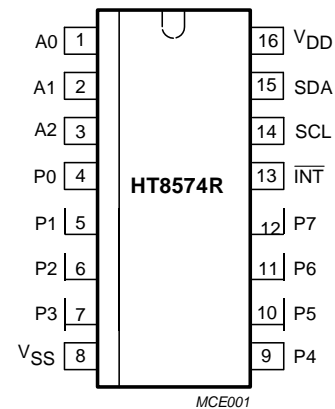
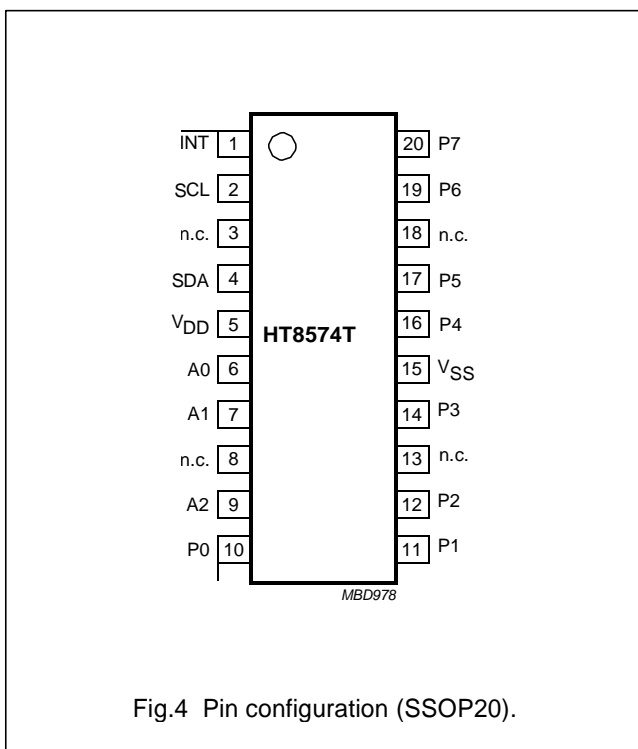

Fig.3 Pin configuration (SO16).

**5.2 SSOP20 package**

SYMBOL	PIN	DESCRIPTION
INT	1	interrupt output (active LOW)
SCL	2	serial clock line
n.c.	3	not connected
SDA	4	serial data line
V <sub>DD</sub>	5	supply voltage
A0	6	address input 0
A1	7	address input 1
n.c.	8	not connected
A2	9	address input 2
P0	10	quasi-bidirectional I/O 0
P1	11	quasi-bidirectional I/O 1
P2	12	quasi-bidirectional I/O 2
n.c.	13	not connected
P3	14	quasi-bidirectional I/O 3
V <sub>SS</sub>	15	supply ground
P4	16	quasi-bidirectional I/O 4
P5	17	quasi-bidirectional I/O 5
n.c.	18	not connected
P6	19	quasi-bidirectional I/O 6
P7	20	quasi-bidirectional I/O 7



## 6 CHARACTERISTICS OF THE I<sup>2</sup>C-BUS

The I<sup>2</sup>C-bus is for 2-way, 2-line communication between different ICs or modules. The two lines are a serial data line (SDA) and a serial clock line (SCL). Both lines must be connected to a positive supply via a pull-up resistor when connected to the output stages of a device. Data transfer may be initiated only when the bus is not busy.

### 6.1 Bit transfer

One data bit is transferred during each clock pulse. The data on the SDA line must remain stable during the HIGH period of the clock pulse as changes in the data line at this time will be interpreted as control signals (see Fig.5).

### 6.2 Start and stop conditions

Both data and clock lines remain HIGH when the bus is not busy. A HIGH-to-LOW transition of the data line, while the clock is HIGH is defined as the start condition (S). A LOW-to-HIGH transition of the data line while the clock is HIGH is defined as the stop condition (P) (see Fig.6).

### 6.3 System configuration

A device generating a message is a 'transmitter', a device receiving is the 'receiver'. The device that controls the message is the 'master' and the devices which are controlled by the master are the 'slaves' (see Fig.7).

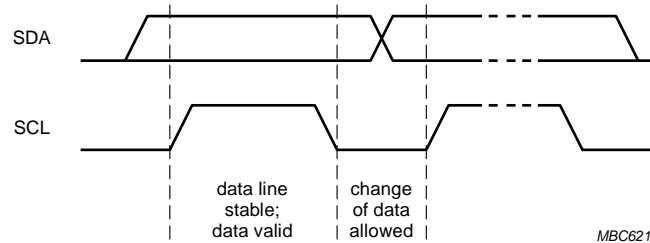

Fig.5 Bit transfer.

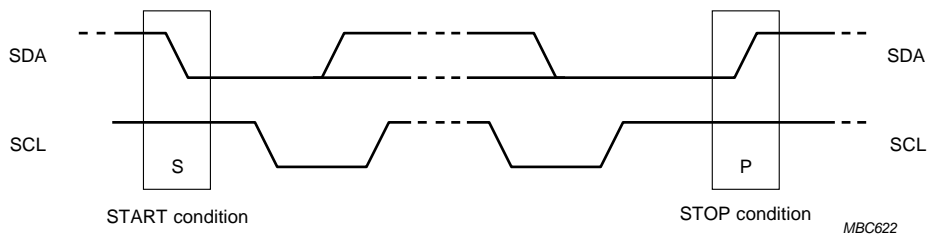

Fig.6 Definition of start and stop conditions.

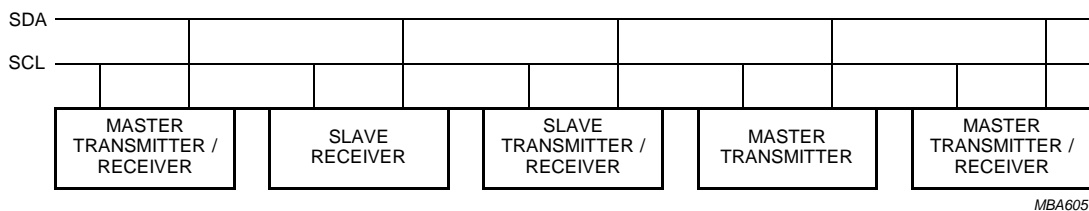

Fig.7 System configuration.

### 6.4 Acknowledge

The number of data bytes transferred between the start and the stop conditions from transmitter to receiver is not limited. Each byte of eight bits is followed by one acknowledge bit (see Fig.8). The acknowledge bit is a HIGH level put on the bus by the transmitter whereas the master generates an extra acknowledge related clock pulse.

A slave receiver which is addressed must generate an acknowledge after the reception of each byte. Also a master must generate an acknowledge after the reception

of each byte that has been clocked out of the slave transmitter. The device that acknowledges has to pull down the SDA line during the acknowledge clock pulse, so that the SDA line is stable LOW during the HIGH period of the acknowledge related clock pulse, set-up and hold times must be taken into account.

A master receiver must signal an end of data to the transmitter by **not** generating an acknowledge on the last byte that has been clocked out of the slave. In this event the transmitter must leave the data line HIGH to enable the master to generate a stop condition.

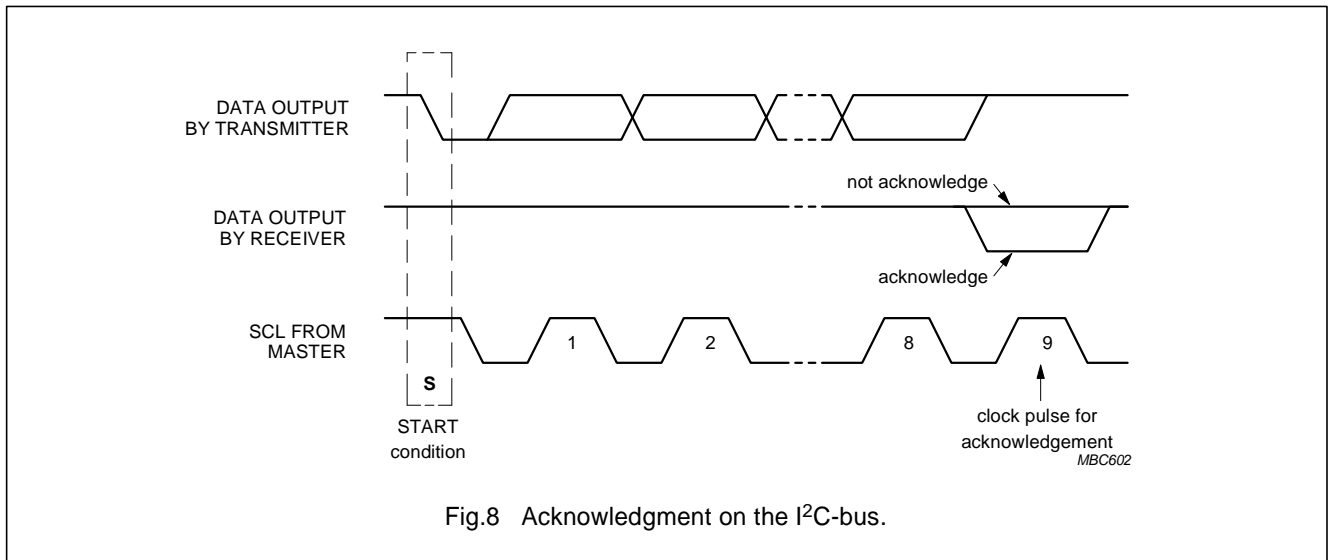

**7 FUNCTIONAL DESCRIPTION**

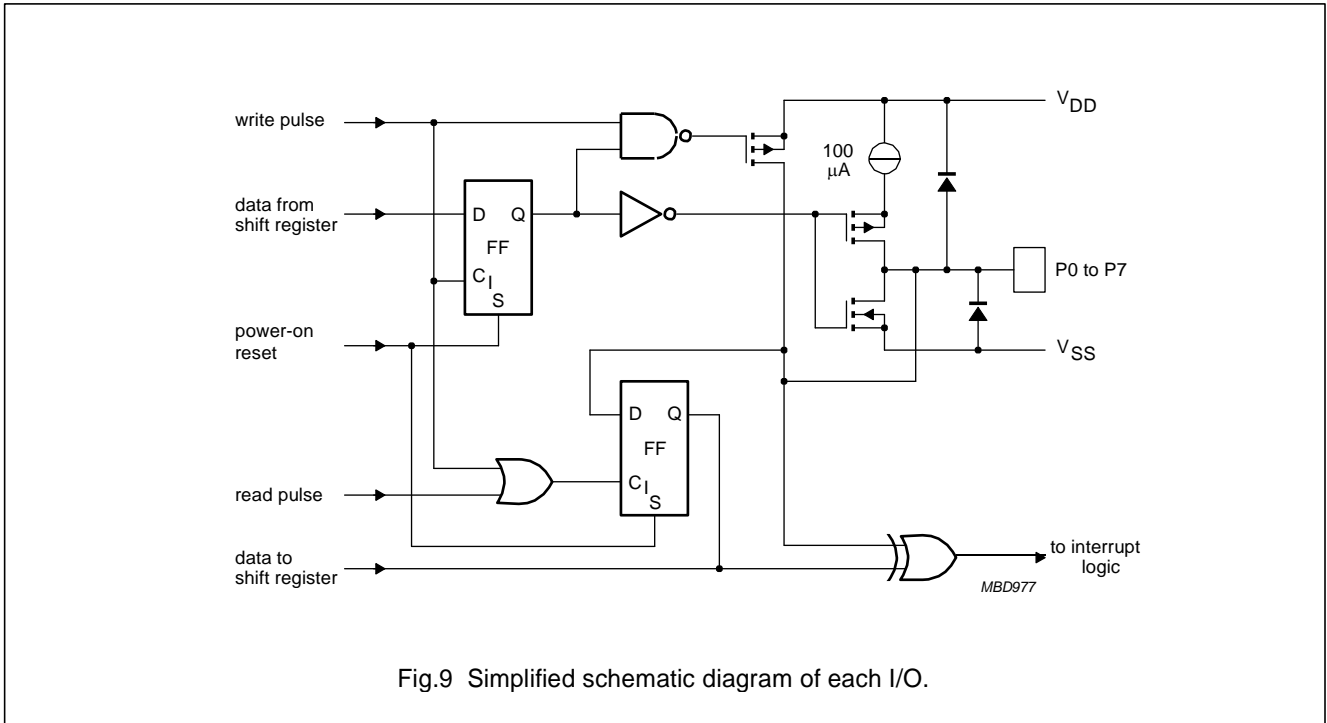

**7.1 Addressing**

For addressing see Figs 10, 11 and 12.

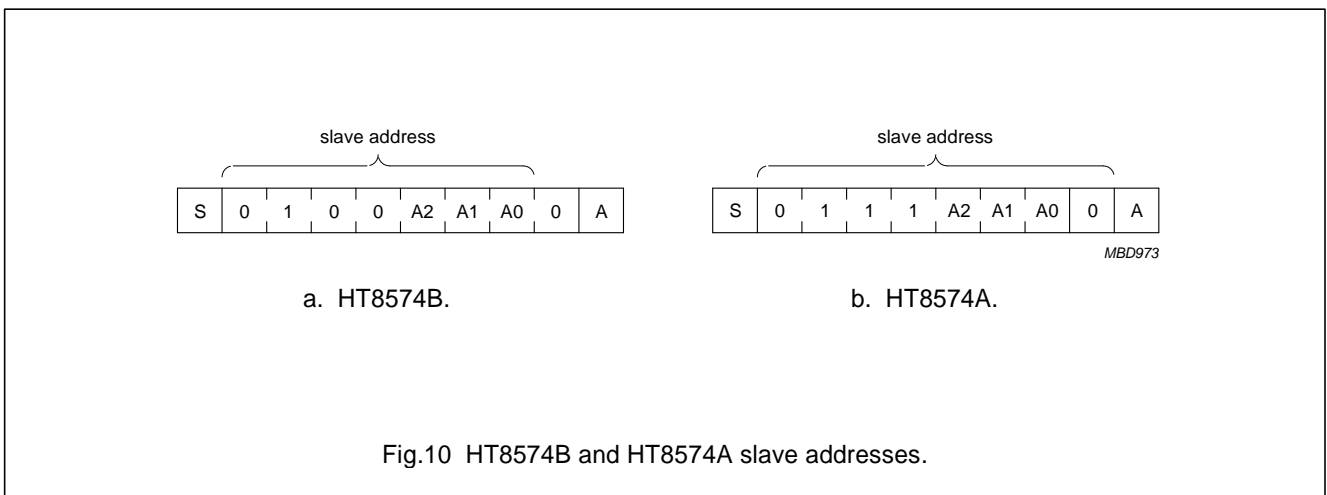

Each of the HT8574B's eight I/Os can be independently used as an input or output. Input data is transferred from the port to the microcontroller by the READ mode (see Fig.12). Output data is transmitted to the port by the WRITE mode (see Fig.11).

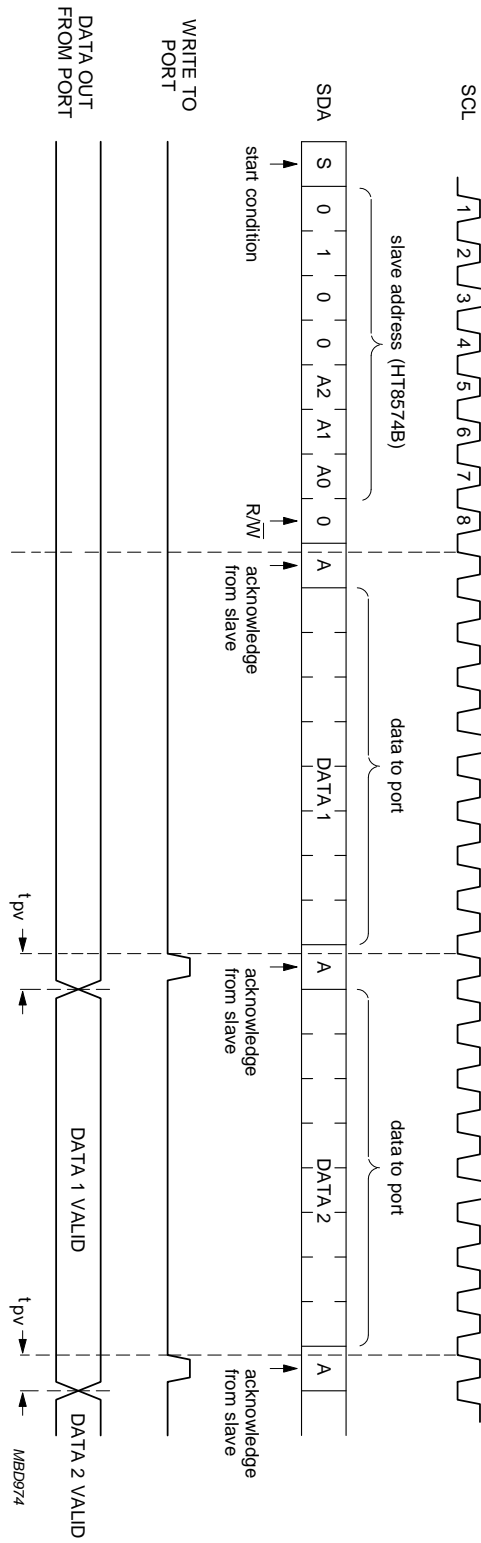
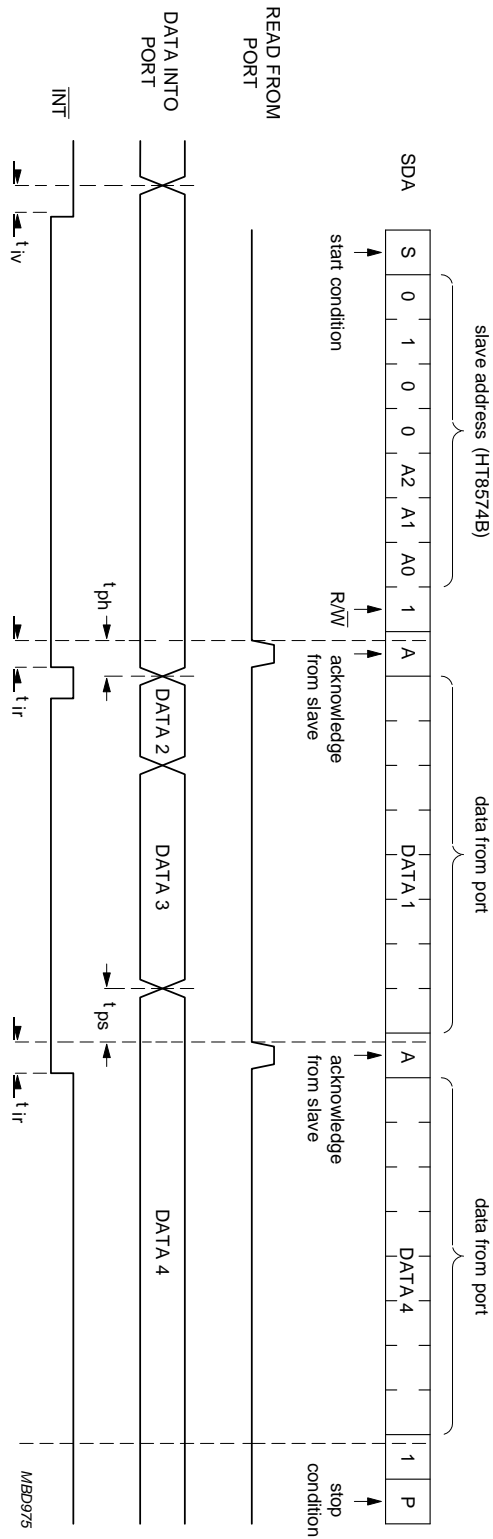

Fig. 11 WRITE mode (output).





A LOW-to-HIGH transition of SDA, while SCL is HIGH is defined as the stop condition (P). Transfer of data can be stopped at any moment by a stop condition. When this occurs, data present at the last acknowledge phase is valid (output mode). Input data is lost.

Fig. 12 READ mode (input).

## 7.2 Interrupt output

The HT8574B provides an open-drain output ( $\overline{\text{INT}}$ ) which can be fed to a corresponding input of the microcontroller (see Figs 13 and 14). This gives these chips a type of master function which can initiate an action elsewhere in the system.

An interrupt is generated by any rising or falling edge of the port inputs in the input mode. After time  $t_{iv}$  the signal  $\overline{\text{INT}}$  is valid.

Resetting and reactivating the interrupt circuit is achieved when data on the port is changed to the original setting or data is read from or written to the port which has generated the interrupt.

Resetting occurs as follows:

- In the READ mode at the acknowledge bit after the rising edge of the SCL signal
- In the WRITE mode at the acknowledge bit after the HIGH-to-LOW transition of the SCL signal

- Interrupts which occur during the acknowledge clock pulse may be lost (or very short) due to the resetting of the interrupt during this pulse.

Each change of the I/Os after resetting will be detected and, after the next rising clock edge, will be transmitted as  $\overline{\text{INT}}$ . Reading from or writing to another device does not affect the interrupt circuit.

## 7.3 Quasi-bidirectional I/Os

A quasi-bidirectional I/O can be used as an input or output without the use of a control signal for data direction (see Fig. 15). At power-on the I/Os are HIGH. In this mode only a current source to  $V_{DD}$  is active. An additional strong pull-up to  $V_{DD}$  allows fast rising edges into heavily loaded outputs. These devices turn on when an output is written HIGH, and are switched off by the negative edge of SCL. The I/Os should be HIGH before being used as inputs.

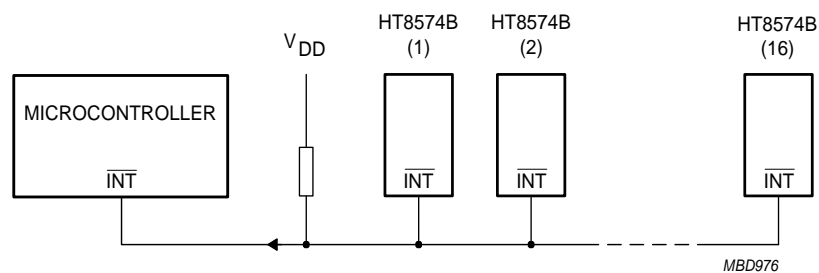

Fig.13 Application of multiple HT8574Bs with interrupt.

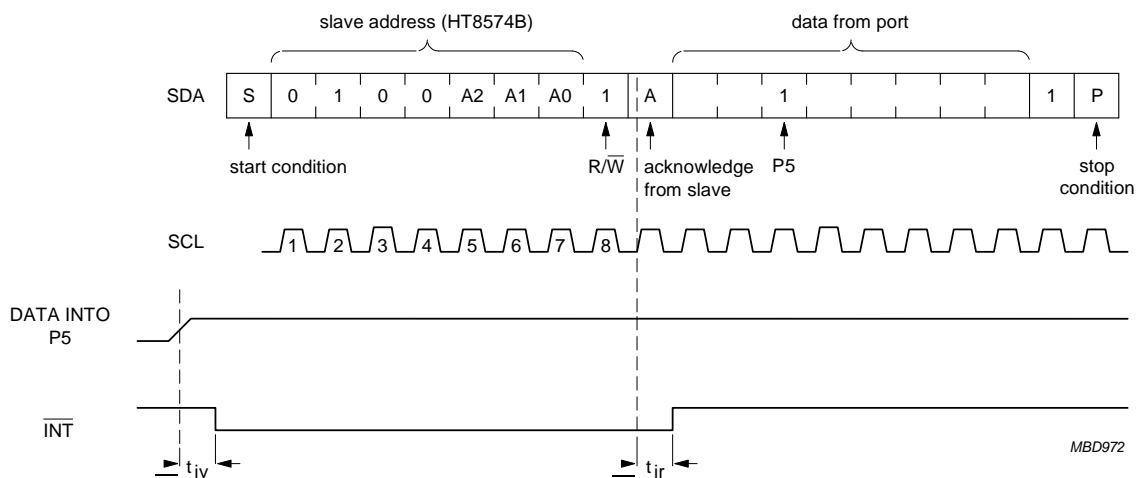

Fig.14 Interrupt generated by a change of input to I/O P5.

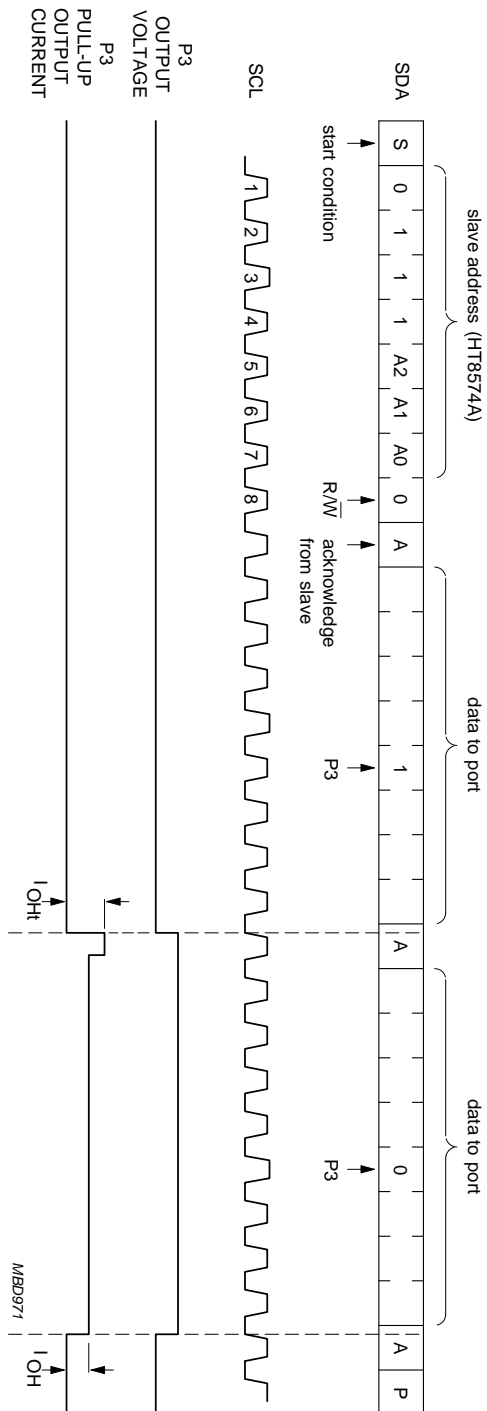

Fig. 15 Transient pull-up current  $I_{OH}$  while P3 changes from LOW-to-HIGH and back to LOW.

## 8 LIMITING VALUES

In accordance with the Absolute Maximum Rating System (IEC 60134).

SYMBOL	PARAMETER	MIN.	MAX.	UNIT
$V_{DD}$	supply voltage	-0.5	+7.0	V
$V_I$	input voltage	$V_{SS} - 0.5$	$V_{DD} + 0.5$	V
$I_I$	DC input current	-	±20	mA
$I_O$	DC output current	-	±25	mA
$I_{DD}$	supply current	-	±100	mA
$I_{SS}$	supply current	-	±100	mA
$P_{tot}$	total power dissipation	-	400	mW
$P_O$	power dissipation per output	-	100	mW
$T_{stg}$	storage temperature	-65	+150	°C
$T_{amb}$	ambient temperature	-40	+85	°C

## 9 HANDLING

Inputs and outputs are protected against electrostatic discharge in normal handling. However it is good practice to take normal precautions appropriate to handling MOS devices (see "Handling MOS devices").

## 10 DC CHARACTERISTICS

$V_{DD} = 2.5$  to  $6$  V;  $V_{SS} = 0$  V;  $T_{amb} = -40$  to  $+85$  °C; unless otherwise specified.

SYMBOL	PARAMETER	CONDITIONS	MIN.	TYP.	MAX.	UNIT
<b>Supply</b>						
$V_{DD}$	supply voltage		2.5	-	6.0	V
$I_{DD}$	supply current	operating mode; $V_{DD} = 6$ V; no load; $V_I = V_{DD}$ or $V_{SS}$ ; $f_{SCL} = 100$ kHz	-	40	100	μA
$I_{stb}$	standby current	standby mode; $V_{DD} = 6$ V; no load; $V_I = V_{DD}$ or $V_{SS}$	-	2.5	10	μA
$V_{POR}$	Power-on reset voltage	$V_{DD} = 6$ V; no load; $V_I = V_{DD}$ or $V_{SS}$ ; note 1	-	1.3	2.4	V
<b>Input SCL; input/output SDA</b>						
$V_{IL}$	LOW level input voltage		-0.5	-	+0.3 $V_{DD}$	V
$V_{IH}$	HIGH level input voltage		0.7 $V_{DD}$	-	$V_{DD} + 0.5$	V
$I_{OL}$	LOW level output current	$V_{OL} = 0.4$ V	3	-	-	mA
$I_L$	leakage current	$V_I = V_{DD}$ or $V_{SS}$	-1	-	+1	μA
$C_i$	input capacitance	$V_I = V_{SS}$	-	-	7	pF

SYMBOL	PARAMETER	CONDITIONS	MIN.	TYP.	MAX.	UNIT
<b>I/Os</b>						
$V_{IL}$	LOW level input voltage		-0.5	-	+0.3 $V_{DD}$	V
$V_{IH}$	HIGH level input voltage		0.7 $V_{DD}$	-	$V_{DD} + 0.5$	V
$I_{IHL(max)}$	maximum allowed input current through protection diode	$V_I \geq V_{DD}$ or $V_I \leq V_{SS}$	-	-	$\pm 400$	$\mu A$
$I_{OL}$	LOW level output current	$V_{OL} = 1\text{ V}; V_{DD} = 5\text{ V}$	10	25	-	mA
$I_{OH}$	HIGH level output current	$V_{OH} = V_{SS}$	30	-	300	$\mu A$
$I_{Oht}$	transient pull-up current	HIGH during acknowledge (see Fig.15); $V_{OH} = V_{SS}$ ; $V_{DD} = 2.5\text{ V}$	-	-1	-	mA
$C_i$	input capacitance		-	-	10	pF
$C_o$	output capacitance		-	-	10	pF
<b>Port timing; <math>C_L \leq 100\text{ pF}</math> (see Figs 11 and 12)</b>						
$t_{pv}$	output data valid		-	-	4	$\mu s$
$t_{su}$	input data set-up time		0	-	-	$\mu s$
$t_h$	input data hold time		4	-	-	$\mu s$
<b>Interrupt INT (see Fig.14)</b>						
$I_{OL}$	LOW level output current	$V_{OL} = 0.4\text{ V}$	1.6	-	-	mA
$I_L$	leakage current	$V_I = V_{DD}$ or $V_{SS}$	-1	-	+1	$\mu A$
<b>TIMING; <math>C_L \leq 100\text{ pF}</math></b>						
$t_{iv}$	input data valid time		-	-	4	$\mu s$
$t_{ir}$	reset delay time		-	-	4	$\mu s$
<b>Select inputs A0 to A2</b>						
$V_{IL}$	LOW level input voltage		-0.5	-	+0.3 $V_{DD}$	V
$V_{IH}$	HIGH level input voltage		0.7 $V_{DD}$	-	$V_{DD} + 0.5$	V
$I_{LI}$	input leakage current	pin at $V_{DD}$ or $V_{SS}$	-250	-	+250	nA

**Note**

1. The Power-on reset circuit resets the I<sup>2</sup>C-bus logic at  $V_{DD} < V_{POR}$  and sets all I/Os to logic 1 (with current source to  $V_{DD}$ ).

**11 I<sup>2</sup>C-BUS TIMING CHARACTERISTICS**

SYMBOL	PARAMETER	MIN.	TYP.	MAX.	UNIT
<b>I<sup>2</sup>C-bus timing</b> (see Fig.16; note 1)					
f <sub>SCL</sub>	SCL clock frequency	–	–	100	kHz
t <sub>SW</sub>	tolerable spike width on bus	–	–	100	ns
t <sub>BUF</sub>	bus free time	4.7	–	–	μs
t <sub>SU;STA</sub>	START condition set-up time	4.7	–	–	μs
t <sub>HD;STA</sub>	START condition hold time	4.0	–	–	μs
t <sub>LOW</sub>	SCL LOW time	4.7	–	–	μs
t <sub>HIGH</sub>	SCL HIGH time	4.0	–	–	μs
t <sub>r</sub>	SCL and SDA rise time	–	–	1.0	μs
t <sub>f</sub>	SCL and SDA fall time	–	–	0.3	μs
t <sub>SU;DAT</sub>	data set-up time	250	–	–	ns
t <sub>HD;DAT</sub>	data hold time	0	–	–	ns
t <sub>VD;DAT</sub>	SCL LOW to data out valid	–	–	3.4	μs
t <sub>SU;STO</sub>	STOP condition set-up time	4.0	–	–	μs

**Note**

- All the timing values are valid within the operating supply voltage and ambient temperature range and refer to V<sub>IL</sub> and V<sub>IH</sub> with an input voltage swing of V<sub>SS</sub> to V<sub>DD</sub>.

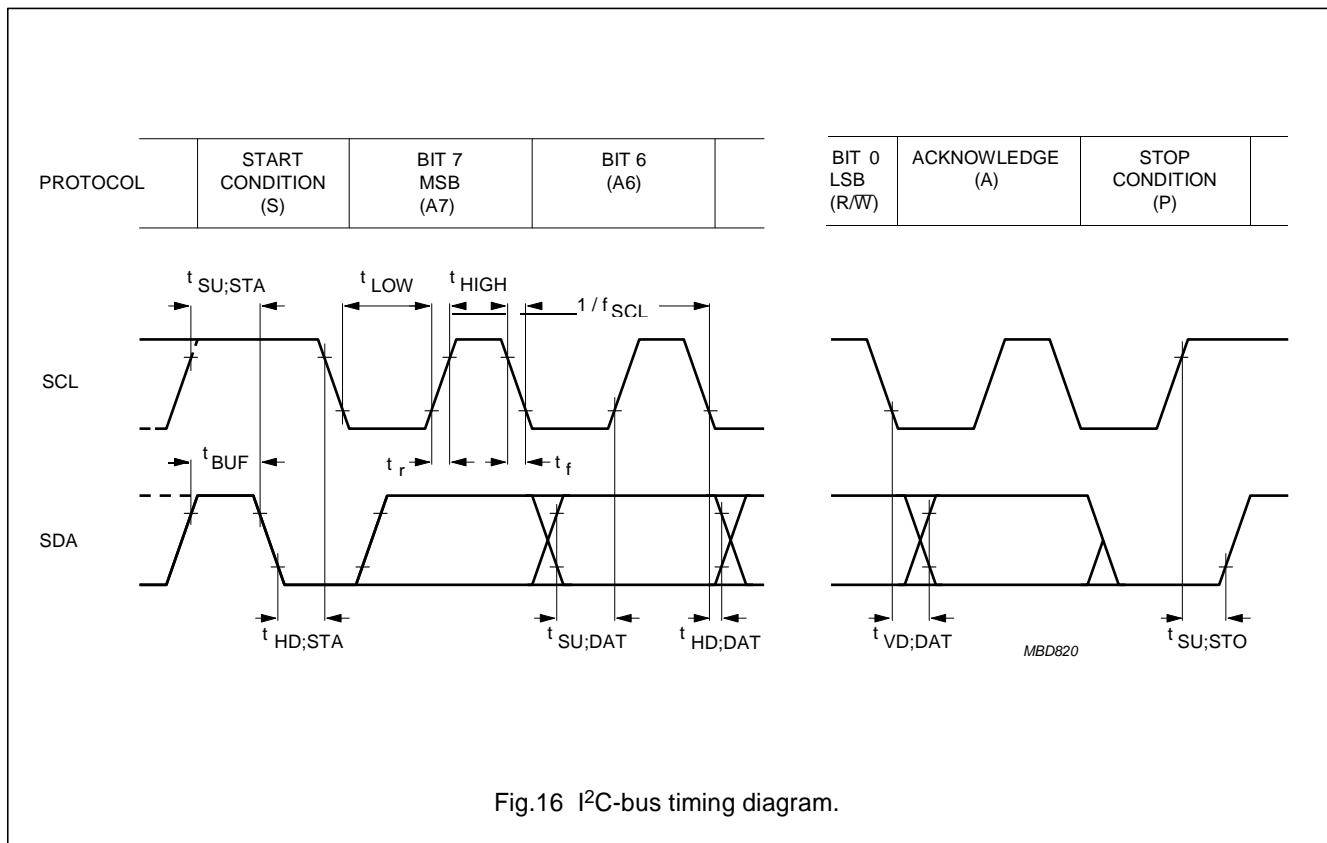

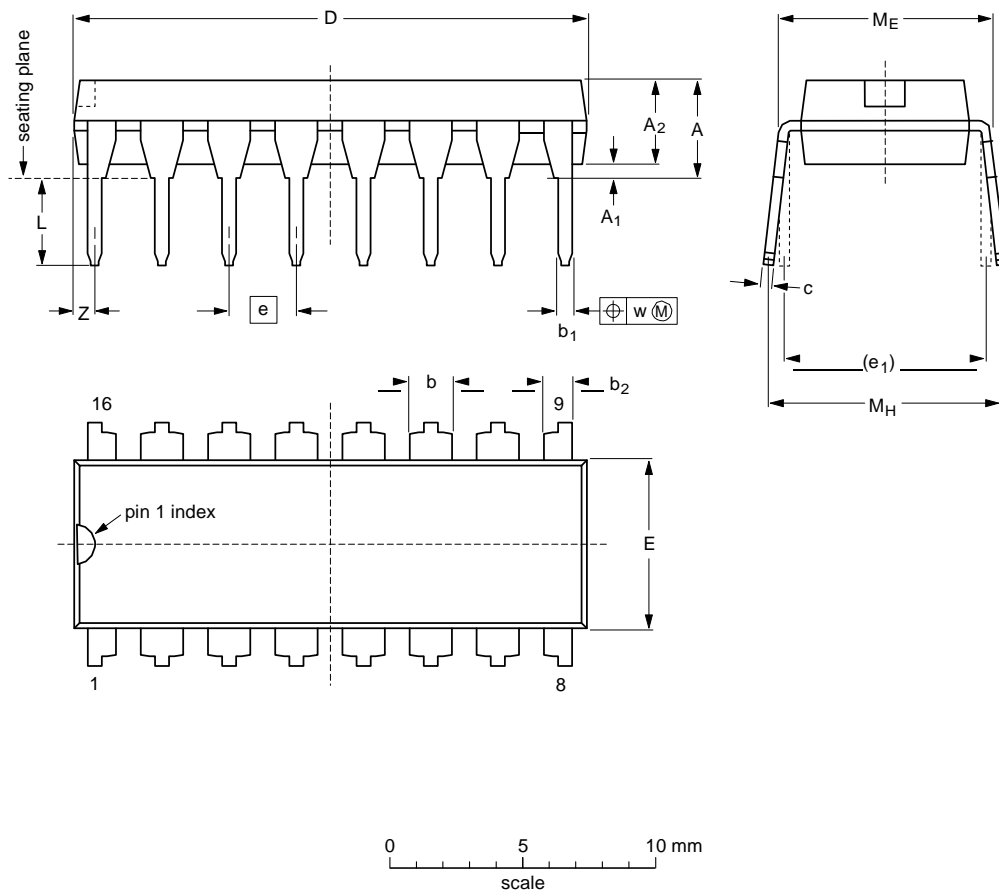
 Fig.16 I<sup>2</sup>C-bus timing diagram.

**12 PACKAGE OUTLINES**
**DIP16: plastic dual in-line package; 16 leads (300 mil)**
**SOT38-4**

**DIMENSIONS (inch dimensions are derived from the original mm dimensions)**

UNIT	A max.	A <sub>1</sub> min.	A <sub>2</sub> max.	b	b <sub>1</sub>	b <sub>2</sub>	c	D <sup>(1)</sup>	E <sup>(1)</sup>	e	e <sub>1</sub>	L	M <sub>E</sub>	M <sub>H</sub>	w	z <sup>(1)</sup> max.
mm	4.2	0.51	3.2	1.73 1.30	0.53 0.38	1.25 0.85	0.36 0.23	19.50 18.55	6.48 6.20	2.54	7.62	3.60 3.05	8.25 7.80	10.0 8.3	0.254	0.76
inches	0.17	0.020	0.13	0.068 0.051	0.021 0.015	0.049 0.033	0.014 0.009	0.77 0.73	0.26 0.24	0.10	0.30	0.14 0.12	0.32 0.31	0.39 0.33	0.01	0.030

**Note**

1. Plastic or metal protrusions of 0.25 mm maximum per side are not included.

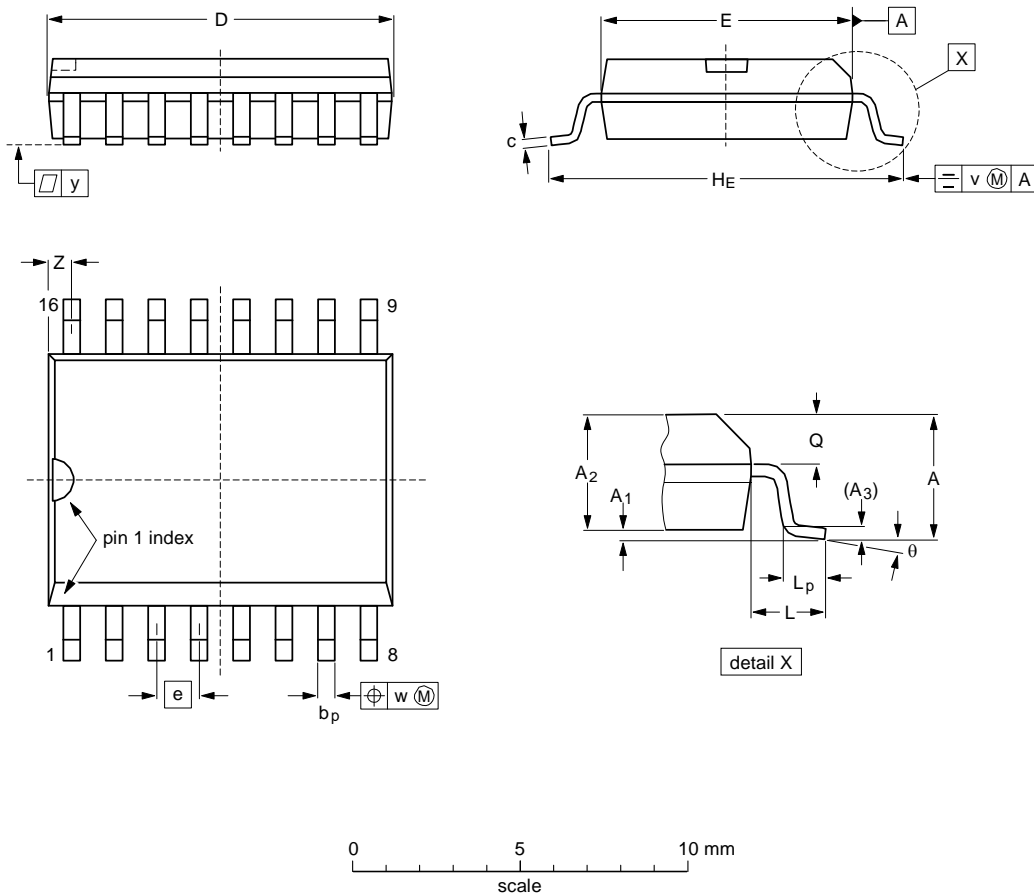
OUTLINE VERSION	REFERENCES				EUROPEAN PROJECTION	ISSUE DATE
	IEC	JEDEC	EIAJ			
SOT38-4						92-11-17 95-01-14

**SO16: plastic small outline package; 16 leads; body width 7.5 mm**
**SOT162-1**

**DIMENSIONS (inch dimensions are derived from the original mm dimensions)**

UNIT	A max.	A <sub>1</sub>	A <sub>2</sub>	A <sub>3</sub>	b <sub>p</sub>	c	D <sup>(1)</sup>	E <sup>(1)</sup>	e	H <sub>E</sub>	L	L <sub>p</sub>	Q	v	w	y	Z <sup>(1)</sup>	θ
mm	2.65	0.30 0.10	2.45 2.25	0.25	0.49 0.36	0.32 0.23	10.5 10.1	7.6 7.4	1.27	10.65 10.00	1.4	1.1 0.4	1.1 1.0	0.25	0.25	0.1	0.9 0.4	8° 0°
inches	0.10	0.012 0.004	0.096 0.089	0.01	0.019 0.014	0.013 0.009	0.41 0.40	0.30 0.29	0.050	0.419 0.394	0.055	0.043 0.016	0.043 0.039	0.01	0.01	0.004	0.035 0.016	

**Note**

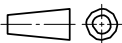
1. Plastic or metal protrusions of 0.15 mm maximum per side are not included.

OUTLINE VERSION	REFERENCES				EUROPEAN PROJECTION	ISSUE DATE
	IEC	JEDEC	EIAJ			
SOT162-1	075E03	MS-013				97-05-22 99-12-27



SSOP20: plastic shrink small outline package; 20 leads; body width 4.4 mm

SOT266-1

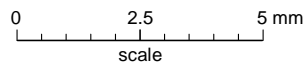
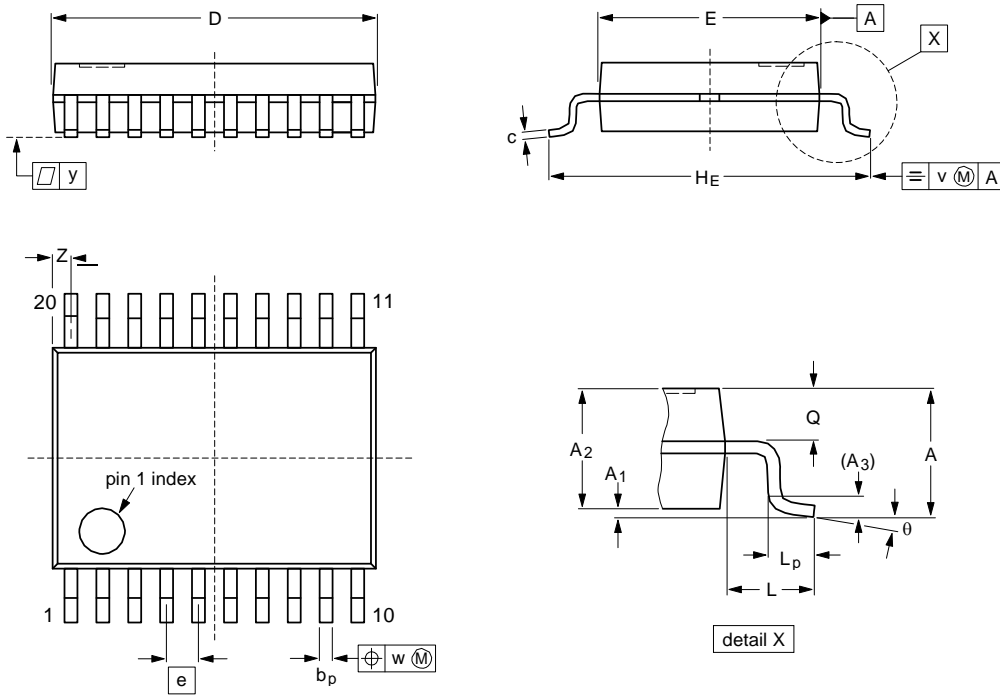

**DIMENSIONS (mm are the original dimensions)**

UNIT	A max.	A <sub>1</sub>	A <sub>2</sub>	A <sub>3</sub>	b <sub>p</sub>	c	D <sup>(1)</sup>	E <sup>(1)</sup>	e	HE	L	L <sub>p</sub>	Q	v	w	y	Z <sup>(1)</sup>	θ
mm	1.5	0.15 0	1.4 1.2	0.25	0.32 0.20	0.20 0.13	6.6 6.4	4.5 4.3	0.65	6.6 6.2	1.0	0.75 0.45	0.65 0.45	0.2	0.13	0.1	0.48 0.18	10° 0°

**Note**

1. Plastic or metal protrusions of 0.20 mm maximum per side are not included.

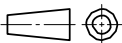
OUTLINE VERSION	REFERENCES				EUROPEAN PROJECTION	ISSUE DATE
	IEC	JEDEC	EIAJ			
SOT266-1		MO-152				95-02-22 99-12-27

## 13 SOLDERING

### 13.1 Introduction

This text gives a very brief insight to a complex technology. A more in-depth account of soldering ICs can be found in our “*Data Handbook IC26; Integrated Circuit Packages*” (document order number 9398 652 90011).

There is no soldering method that is ideal for all IC packages. Wave soldering is often preferred when through-hole and surface mount components are mixed on one printed-circuit board. Wave soldering can still be used for certain surface mount ICs, but it is not suitable for fine pitch SMDs. In these situations reflow soldering is recommended.

### 13.2 Through-hole mount packages

#### 13.2.1 SOLDERING BY DIPPING OR BY SOLDER WAVE

The maximum permissible temperature of the solder is 260 °C; solder at this temperature must not be in contact with the joints for more than 5 seconds. The total contact time of successive solder waves must not exceed 5 seconds.

The device may be mounted up to the seating plane, but the temperature of the plastic body must not exceed the specified maximum storage temperature ( $T_{stg(max)}$ ). If the printed-circuit board has been pre-heated, forced cooling may be necessary immediately after soldering to keep the temperature within the permissible limit.

#### 13.2.2 MANUAL SOLDERING

Apply the soldering iron (24 V or less) to the lead(s) of the package, either below the seating plane or not more than 2 mm above it. If the temperature of the soldering iron bit is less than 300 °C it may remain in contact for up to 10 seconds. If the bit temperature is between 300 and 400 °C, contact may be up to 5 seconds.

### 13.3 Surface mount packages

#### 13.3.1 REFLOW SOLDERING

Reflow soldering requires solder paste (a suspension of fine solder particles, flux and binding agent) to be applied to the printed-circuit board by screen printing, stencilling or pressure-syringe dispensing before package placement.

Several methods exist for reflowing; for example, convection or convection/infrared heating in a conveyor type oven. Throughput times (preheating, soldering and cooling) vary between 100 and 200 seconds depending on heating method.

Typical reflow peak temperatures range from 215 to 250 °C. The top-surface temperature of the packages should preferably be kept below 220 °C for thick/large packages, and below 235 °C for small/thin packages.

#### 13.3.2 WAVE SOLDERING

Conventional single wave soldering is not recommended for surface mount devices (SMDs) or printed-circuit boards with a high component density, as solder bridging and non-wetting can present major problems.

To overcome these problems the double-wave soldering method was specifically developed.

If wave soldering is used the following conditions must be observed for optimal results:

- Use a double-wave soldering method comprising a turbulent wave with high upward pressure followed by a smooth laminar wave.
- For packages with leads on two sides and a pitch (e):
  - larger than or equal to 1.27 mm, the footprint longitudinal axis is **preferred** to be parallel to the transport direction of the printed-circuit board;
  - smaller than 1.27 mm, the footprint longitudinal axis **must** be parallel to the transport direction of the printed-circuit board.

The footprint must incorporate solder thieves at the downstream end.

- For packages with leads on four sides, the footprint must be placed at a 45° angle to the transport direction of the printed-circuit board. The footprint must incorporate solder thieves downstream and at the side corners.

During placement and before soldering, the package must be fixed with a droplet of adhesive. The adhesive can be applied by screen printing, pin transfer or syringe dispensing. The package can be soldered after the adhesive is cured.

Typical dwell time is 4 seconds at 250 °C.

A mildly-activated flux will eliminate the need for removal of corrosive residues in most applications.

#### 13.3.3 MANUAL SOLDERING

Fix the component by first soldering two diagonally-opposite end leads. Use a low voltage (24 V or less) soldering iron applied to the flat part of the lead. Contact time must be limited to 10 seconds at up to 300 °C. When using a dedicated tool, all other leads can be soldered in one operation within 2 to 5 seconds between 270 and 320 °C.

**14 DATA SHEET STATUS**

LEVEL	DATA SHEET STATUS <sup>(1)</sup>	PRODUCT STATUS <sup>(2)(3)</sup>	DEFINITION
I	Objective data	Development	This data sheet contains data from the objective specification for product development. Philips Semiconductors reserves the right to change the specification in any manner without notice.
II	Preliminary data	Qualification	This data sheet contains data from the preliminary specification. Supplementary data will be published at a later date. Philips Semiconductors reserves the right to change the specification without notice, in order to improve the design and supply the best possible product.
III	Product data	Production	This data sheet contains data from the product specification. Philips Semiconductors reserves the right to make changes at any time in order to improve the design, manufacturing and supply. Relevant changes will be communicated via a Customer Product/Process Change Notification (CPCN).

**Notes**

1. Please consult the most recently issued data sheet before initiating or completing a design.
2. The product status of the device(s) described in this data sheet may have changed since this data sheet was published. The latest information is available on the Internet at URL <http://www.semiconductors.philips.com>.
3. For data sheets describing multiple type numbers, the highest-level product status determines the data sheet status.

**15 DEFINITIONS**

**Short-form specification** — The data in a short-form specification is extracted from a full data sheet with the same type number and title. For detailed information see the relevant data sheet or data handbook.

**Limiting values definition** — Limiting values given are in accordance with the Absolute Maximum Rating System (IEC 60134). Stress above one or more of the limiting values may cause permanent damage to the device.

These are stress ratings only and operation of the device at these or at any other conditions above those given in the Characteristics sections of the specification is not implied. Exposure to limiting values for extended periods may affect device reliability.

**Application information** — Applications that are described herein for any of these products are for illustrative purposes only. Philips Semiconductors make no representation or warranty that such applications will be suitable for the specified use without further testing or modification.

**16 DISCLAIMERS**

**Life support applications** — These products are not designed for use in life support appliances, devices, or systems where malfunction of these products can reasonably be expected to result in personal injury. Philips Semiconductors customers using or selling these products for use in such applications do so at their own risk and agree to fully indemnify Philips Semiconductors for any damages resulting from such application.

**Right to make changes** — Philips Semiconductors reserves the right to make changes in the products - including circuits, standard cells, and/or software - described or contained herein in order to improve design and/or performance. When the product is in full production (status 'Production'), relevant changes will be communicated via a Customer Product/Process Change Notification (CPCN). Philips Semiconductors assumes no responsibility or liability for the use of any of these products, conveys no licence or title under any patent, copyright, or mask work right to these products, and makes no representations or warranties that these products are free from patent, copyright, or mask work right infringement, unless otherwise specified.