

Micropower Programmable Operator Amplifier

(compatible to TLC251&TLC271 (TI USA))

This extremely versatile operational amplifier features low power consumption and high input impedance. In addition, the quiescent currents within the device may be programmed by the choice of an external resistor value or current source applied to the I_{set} input. This allows the amplifier's characteristics to be optimized for input current and power consumption despite wide variations in operating power supply voltages.

- $\pm 1.2\text{ V}$ to $\pm 18\text{ V}$ Operation
- Wide Programming Range
- Offset Null Capability
- No Frequency Compensation Required
- Low Input Bias Currents
- Short Circuit Protection

Resistive Programming

(See Figure 1)

R_{set} to Ground

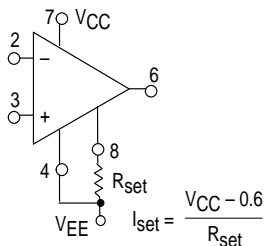

R_{set} to Negative Supply

(Recommended for supply voltage less than $\pm 6.0\text{ V}$)

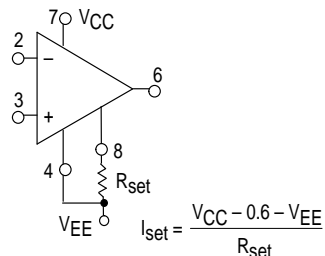

Typical R_{set} Values		
V_{CC}, V_{EE}	$I_{set} = 1.5\ \mu\text{A}$	$I_{set} = 15\ \mu\text{A}$
$\pm 6.0\text{ V}$	3.6 M Ω	360 k Ω
$\pm 10\text{ V}$	6.2 M Ω	620 k Ω
$\pm 12\text{ V}$	7.5 M Ω	750 k Ω
$\pm 15\text{ V}$	10 M Ω	1.0 M Ω

Typical R_{set} Values		
V_{CC}, V_{EE}	$I_{set} = 1.5\ \mu\text{A}$	$I_{set} = 15\ \mu\text{A}$
$\pm 1.5\text{ V}$	1.6 M Ω	160 k Ω
$\pm 3.0\text{ V}$	3.6 M Ω	360 k Ω
$\pm 6.0\text{ V}$	7.5 M Ω	750 k Ω
$\pm 15\text{ V}$	20 M Ω	2.0 M Ω

Active Programming

FET Current Source

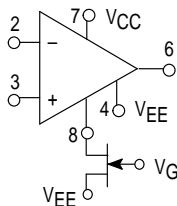

Bipolar Current Source

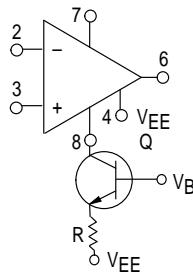

Pins not shown are not connected.

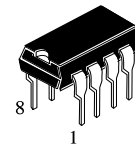

DIP8-8 N SUFFIX
HT8776BNZ

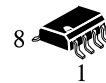

SOP-8 R SUFFIX
HT8776BRZ



MSOP-8 M SUFFIX
HT8776BRMZ

$T_A = 0^\circ$ to 70°C for all packages.

NOTE: suffix B is version, suffix R is roll tape, suffix Z environmental protection.

PIN CONNECTIONS

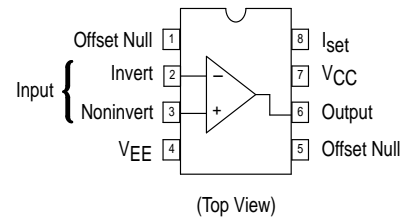

MAXIMUM RATINGS ($T_A = +25^\circ\text{C}$, unless otherwise noted.)

Rating	Symbol	Value	Unit
Power Supply Voltages	V_{CC}, V_{EE}	± 18	Vdc
Differential Input Voltage	V_{ID}	± 30	Vdc
Common Mode Input Voltage V_{CC} and $ V_{EE} < 15\text{ V}$ V_{CC} and $ V_{EE} \geq 15\text{ V}$	V_{ICM}	V_{CC}, V_{EE} ± 15	Vdc
Offset Null to V_{EE} Voltage	$V_{off-V_{EE}}$	± 0.5	Vdc
Programming Current	I_{set}	500	μA
Programming Voltage (Voltage from I_{set} Terminal to Ground)	V_{set}	$(V_{CC} - 2.0\text{ V})$ to V_{CC}	Vdc
Output Short Circuit Duration (Note 1)	t_{SC}	Indefinite	sec
Operating Temperature Range	T_A	0 to $+70$	$^\circ\text{C}$
Storage Temperature Range	T_{stg}	-65 to $+150$	$^\circ\text{C}$
Junction Temperature	T_J	150	$^\circ\text{C}$

NOTE 1. May be to ground or either supply voltage. Rating applies up to a case temperature of $+125^\circ\text{C}$ or ambient temperature of $+70^\circ\text{C}$ and $I_{set} \leq 30\ \mu\text{A}$.

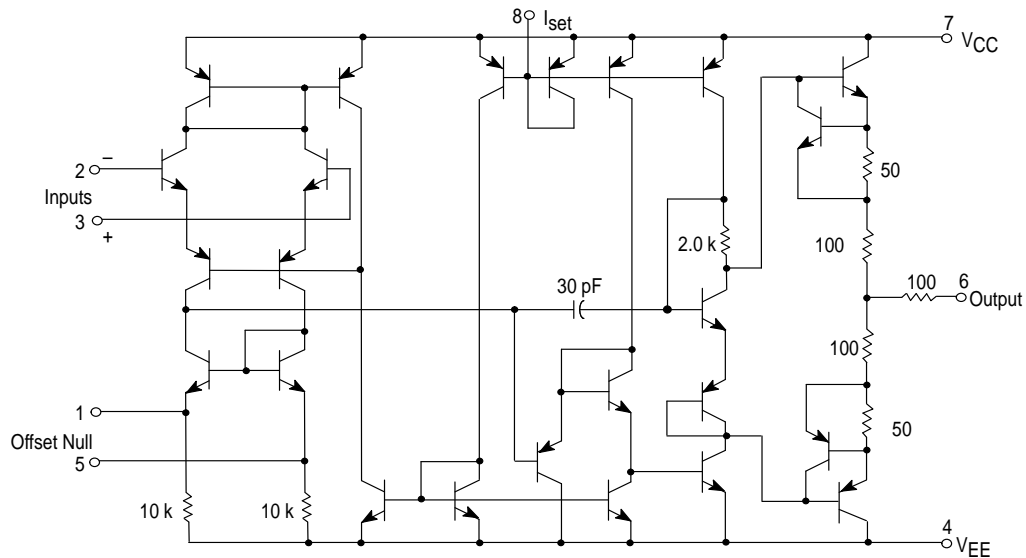
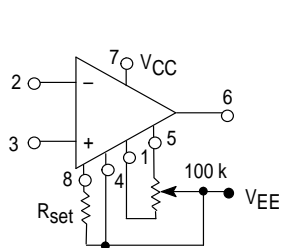
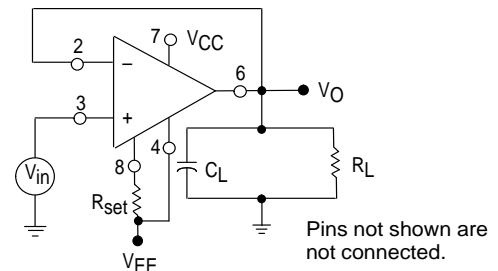
Representative Schematic Diagram

Voltage Offset Null Circuit

Transient Response Test Circuit

ELECTRICAL CHARACTERISTICS ($V_{CC} = +3.0\text{ V}$, $V_{EE} = -3.0\text{ V}$, $I_{set} = 1.5\text{ }\mu\text{A}$, $T_A = +25^\circ\text{C}$, unless otherwise noted.)

Characteristic	Symbol	Min	Typ	Max	Unit
Input Offset Voltage ($R_S \leq 10\text{ k}\Omega$) $T_A = +25^\circ\text{C}$ $T_{low}^* \leq T_A \leq T_{high}^*$	V_{IO}	–	2.0	6.0	mV
Offset Voltage Adjustment Range	V_{IOR}	–	9.0	–	mV
Input Offset Current $T_A = +25^\circ\text{C}$ $T_A = T_{high}$ $T_A = T_{low}$	I_{IO}	–	0.7	6.0	nA
Input Bias Current $T_A = +25^\circ\text{C}$ $T_A = T_{high}$ $T_A = T_{low}$	I_{IB}	–	2.0	10	nA
Input Resistance	r_i	–	50	–	M Ω
Input Capacitance	c_i	–	2.0	–	pF
Input Voltage Range $T_{low} \leq T_A \leq T_{high}$	V_{ID}	+1.0	–	–	V
Large Signal Voltage Gain $R_L \geq 75\text{ k}\Omega$, $V_O = \pm 1.0\text{ V}$, $T_A = +25^\circ\text{C}$ $R_L \geq 75\text{ k}\Omega$, $V_O = \pm 1.0\text{ V}$, $T_{low} \leq T_A \leq T_{high}$	A_{VOL}	25 k 25 k	200 k –	– –	V/V
Output Voltage Swing $R_L \geq 75\text{ k}\Omega$, $T_{low} \leq T_A \leq T_{high}$	V_O	± 2.0	± 2.4	–	V
Output Resistance	r_o	–	5.0	–	k Ω
Output Short Circuit Current	I_{SC}	–	3.0	–	mA
Common Mode Rejection $R_S \leq 10\text{ k}\Omega$, $T_{low} \leq T_A \leq T_{high}$	CMR	70	86	–	dB
Supply Voltage Rejection Ratio $R_S \leq 10\text{ k}\Omega$, $T_{low} \leq T_A \leq T_{high}$	PSRR	–	25	200	$\mu\text{V/V}$
Supply Current $T_A = +25^\circ\text{C}$ $T_{low} \leq T_A \leq T_{high}$	I_{CC} , I_{EE}	–	13	20	μA
Power Dissipation $T_A = +25^\circ\text{C}$ $T_{low} \leq T_A \leq T_{high}$	P_D	–	78	120	μW
Transient Response (Unity Gain) $V_{in} = 20\text{ mV}$, $R_L \geq 5.0\text{ k}\Omega$, $C_L = 100\text{ pF}$ Rise Time Overshoot	t_{TLH} t_{os}	–	3.0 0	–	μs %
Slew Rate ($R_L \geq 5.0\text{ k}\Omega$)	SR	–	0.03	–	V/ μs

ELECTRICAL CHARACTERISTICS ($V_{CC} = +3.0\text{ V}$, $V_{EE} = -3.0\text{ V}$, $I_{set} = 15\ \mu\text{A}$, $T_A = +25^\circ\text{C}$, unless otherwise noted.)

Characteristic	Symbol	Min	Typ	Max	Unit
Input Offset Voltage ($R_S \leq 10\text{ k}\Omega$) $T_A = +25^\circ\text{C}$ $T_{low}^* \leq T_A \leq T_{high}^*$	V_{IO}	–	2.0	6.0	mV
Offset Voltage Adjustment Range	V_{IOR}	–	18	–	mV
Input Offset Current $T_A = +25^\circ\text{C}$ $T_A = T_{high}$ $T_A = T_{low}$	I_{IO}	–	2.0	25	nA
Input Bias Current $T_A = +25^\circ\text{C}$ $T_A = T_{high}$ $T_A = T_{low}$	I_{IB}	–	15	50	nA
Input Resistance	r_i	–	5.0	–	$M\Omega$
Input Capacitance	c_i	–	2.0	–	pF
Input Voltage Range $T_{low} \leq T_A \leq T_{high}$	V_{ID}	± 1.0	–	–	V
Large Signal Voltage Gain $R_L \geq 5.0\text{ k}\Omega$, $V_O = \pm 1.0\text{ V}$, $T_A = +25^\circ\text{C}$ $R_L \geq 5.0\text{ k}\Omega$, $V_O = \pm 1.0\text{ V}$, $T_{low} \leq T_A \leq T_{high}$	A_{VOL}	25 k 25 k	200 k –	– –	V/V
Output Voltage Swing $R_L \geq 5.0\text{ k}\Omega$, $T_{low} \leq T_A \leq T_{high}$	V_O	± 2.0	± 2.1	–	V
Output Resistance	r_o	–	1.0	–	$k\Omega$
Output Short Circuit Current	I_{SC}	–	5.0	–	mA
Common Mode Rejection $R_S \leq 10\text{ k}\Omega$, $T_{low} \leq T_A \leq T_{high}$	CMR	70	86	–	dB
Supply Voltage Rejection Ratio $R_S \leq 10\text{ k}\Omega$, $T_{low} \leq T_A \leq T_{high}$	PSRR	–	25	200	$\mu\text{V/V}$
Supply Current $T_A = +25^\circ\text{C}$ $T_{low} \leq T_A \leq T_{high}$	I_{CC} , I_{EE}	–	130	170	μA
Power Dissipation $T_A = +25^\circ\text{C}$ $T_{low} \leq T_A \leq T_{high}$	P_D	–	780	1020	μW
Transient Response (Unity Gain) $V_{in} = 20\text{ mV}$, $R_L \geq 5.0\text{ k}\Omega$, $C_L = 100\text{ pF}$ Rise Time Overshoot	t_{TLH} t_{os}	–	0.6	–	μs %
Slew Rate ($R_L \geq 5.0\text{ k}\Omega$)	S_R	–	0.35	–	$\text{V}/\mu\text{s}$

ELECTRICAL CHARACTERISTICS ($V_{CC} = +15\text{ V}$, $V_{EE} = -15\text{ V}$, $I_{set} = 1.5\text{ }\mu\text{A}$, $T_A = +25^\circ\text{C}$, unless otherwise noted.*)

Characteristic	Symbol	Min	Typ	Max	Unit
Input Offset Voltage ($R_S \leq 10\text{ k}\Omega$) $T_A = +25^\circ\text{C}$ $T_{low}^* \leq T_A \leq T_{high}^*$	V_{IO}	–	2.0	6.0	mV
Offset Voltage Adjustment Range	V_{IOR}	–	9.0	–	mV
Input Offset Current $T_A = +25^\circ\text{C}$ $T_A = T_{high}$ $T_A = T_{low}$	I_{IO}	–	0.7	6.0	nA
Input Bias Current $T_A = +25^\circ\text{C}$ $T_A = T_{high}$ $T_A = T_{low}$	I_{IB}	–	2.0	10	nA
Input Resistance	r_i	–	50	–	M Ω
Input Capacitance	c_i	–	2.0	–	pF
Input Voltage Range $T_{low} \leq T_A \leq T_{high}$	V_{ID}	± 10	–	–	V
Large Signal Voltage Gain $R_L \geq 75\text{ k}\Omega$, $V_O = \pm 10\text{ V}$, $T_A = +25^\circ\text{C}$ $R_L \geq 75\text{ k}\Omega$, $V_O = \pm 10\text{ V}$, $T_{low} \leq T_A \leq T_{high}$	A_{VOL}	50 k 50 k	400 k –	– –	V/V
Output Voltage Swing $R_L \geq 75\text{ k}\Omega$, $T_A = +25^\circ\text{C}$ $R_L \geq 75\text{ k}\Omega$, $T_{low} \leq T_A \leq T_{high}$	V_O	± 12 ± 10	± 14 –	– –	V
Output Resistance	r_o	–	5.0	–	k Ω
Output Short Circuit Current	I_{SC}	–	3.0	–	mA
Common Mode Rejection $R_S \leq 10\text{ k}\Omega$, $T_{low} \leq T_A \leq T_{high}$	CMR	70	90	–	dB
Supply Voltage Rejection Ratio $R_S \leq 10\text{ k}\Omega$, $T_{low} \leq T_A \leq T_{high}$	PSRR	–	25	200	$\mu\text{V/V}$
Supply Current $T_A = +25^\circ\text{C}$ $T_{low} \leq T_A \leq T_{high}$	I_{CC} , I_{EE}	– –	20 –	30 35	μA
Power Dissipation $T_A = +25^\circ\text{C}$ $T_{low} \leq T_A \leq T_{high}$	P_D	– –	780 –	0.9 1.05	mW
Transient Response (Unity Gain) $V_{in} = 20\text{ mV}$, $R_L \geq 5.0\text{ k}\Omega$, $C_L = 100\text{ pF}$ Rise Time Overshoot	t_{TLH} os	– –	1.6 0	– –	μs %
Slew Rate ($R_L \geq 5.0\text{ k}\Omega$)	S_R	–	0.1	–	V/ μs

ELECTRICAL CHARACTERISTICS ($V_{CC} = +15\text{ V}$, $V_{EE} = -15\text{ V}$, $I_{set} = 15\ \mu\text{A}$, $T_A = +25^\circ\text{C}$, unless otherwise noted.)

Characteristic	Symbol	Min	Typ	Max	Unit
Input Offset Voltage ($R_S \leq 10\ \text{k}\Omega$) $T_A = +25^\circ\text{C}$ $T_{low}^* \leq T_A \leq T_{high}^*$	V_{IO}	– –	2.0 –	6.0 7.5	mV
Offset Voltage Adjustment Range	V_{IOR}	–	18	–	mV
Input Offset Current $T_A = +25^\circ\text{C}$ $T_A = T_{high}$ $T_A = T_{low}$	I_{IO}	– – –	2.0 – –	25 25 40	nA
Input Bias Current $T_A = +25^\circ\text{C}$ $T_A = T_{high}$ $T_A = T_{low}$	I_{IB}	– – –	15 – –	50 50 100	nA
Input Resistance	r_i	–	5.0	–	M Ω
Input Capacitance	c_i	–	2.0	–	pF
Input Voltage Range $T_{low} \leq T_A \leq T_{high}$	V_{ID}	± 10	–	–	V
Large Signal Voltage Gain $R_L \geq 5.0\ \text{k}\Omega$, $V_O = \pm 10\ \text{V}$, $T_A = +25^\circ\text{C}$ $R_L \geq 75\ \text{k}\Omega$, $V_O = \pm 10\ \text{V}$, $T_{low} \leq T_A \leq T_{high}$	A_{VOL}	50 k 50 k	400 k –	– –	V/V
Output Voltage Swing $R_L \geq 5.0\ \text{k}\Omega$, $T_A = +25^\circ\text{C}$ $R_L \geq 75\ \text{k}\Omega$, $T_{low} \leq T_A \leq T_{high}$	V_O	± 10 ± 10	± 13 –	– –	V
Output Resistance	r_o	–	1.0	–	k Ω
Output Short Circuit Current	I_{SC}	–	12	–	mA
Common Mode Rejection $R_S \leq 10\ \text{k}\Omega$, $T_{low} \leq T_A \leq T_{high}$	CMR	70	90	–	dB
Supply Voltage Rejection Ratio $R_S \leq 10\ \text{k}\Omega$, $T_{low} \leq T_A \leq T_{high}$	PSRR	–	25	200	$\mu\text{V/V}$
Supply Current $T_A = +25^\circ\text{C}$ $T_{low} \leq T_A \leq T_{high}$	I_{CC} , I_{EE}	– –	160 –	190 200	μA
Power Dissipation $T_A = +25^\circ\text{C}$ $T_{low} \leq T_A \leq T_{high}$	P_D	– –	– –	5.7 6.0	μW
Transient Response (Unity Gain) $V_{in} = 20\ \text{mV}$, $R_L \geq 5.0\ \text{k}\Omega$, $C_L = 100\ \text{pF}$ Rise Time Overshoot	t_{TLH} os	– –	0.35 10	– –	μs %
Slew Rate ($R_L \geq 5.0\ \text{k}\Omega$)	S_R	–	0.8	–	V/ μs

Figure 1. Set Current versus Set Resistor

Figure 2. Positive Standby Supply Current versus Set Current

Figure 3. Open Loop Gain versus Set Current

Figure 4. Input Bias Current versus Set Current

Figure 5. Input Bias Current versus Ambient Temperature

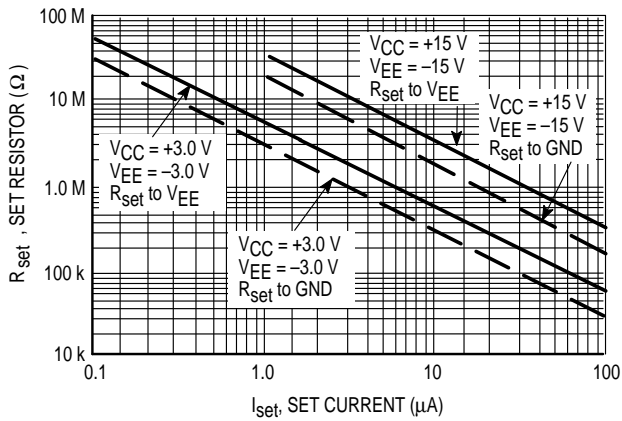
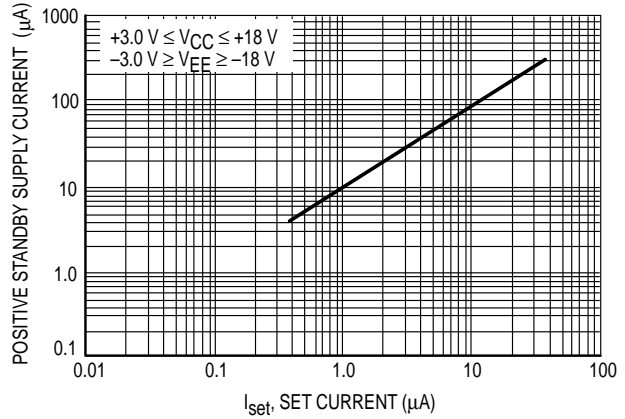
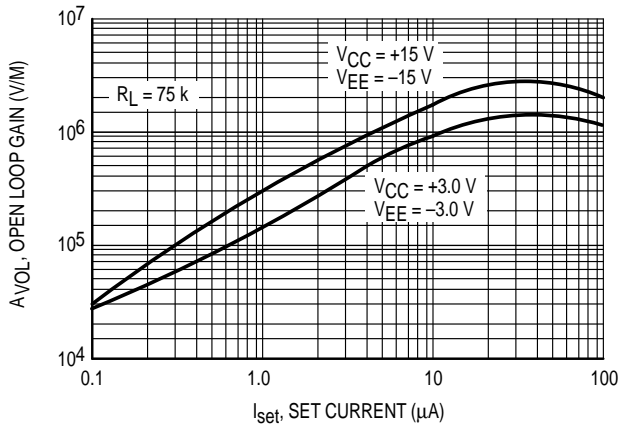
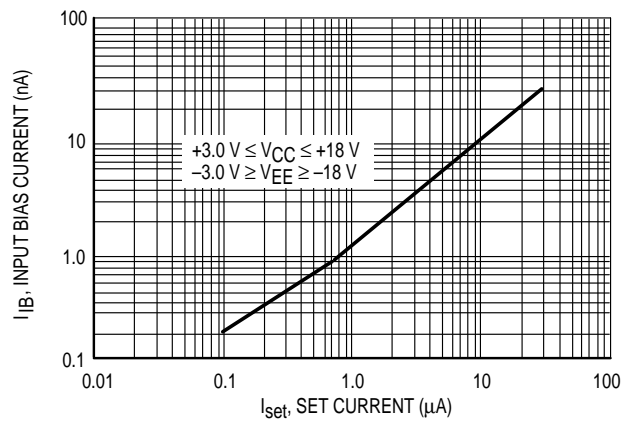
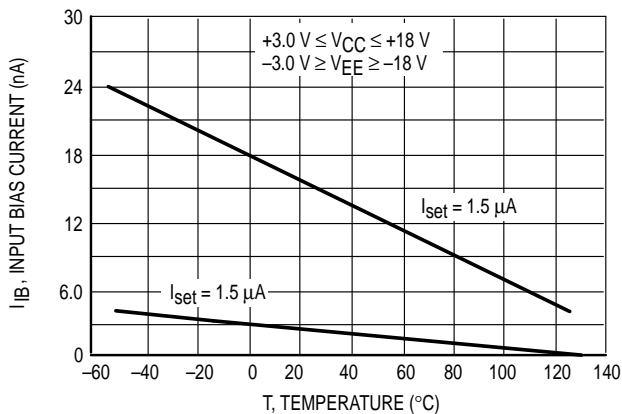
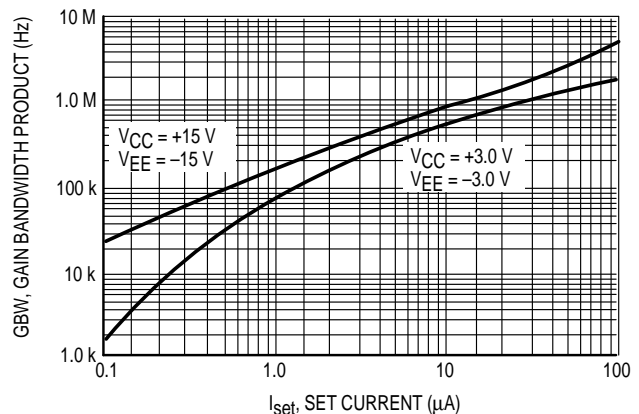
Figure 6. Gain Bandwidth Product versus Set Current

Figure 7. Output Voltage Swing versus Load Resistance

Figure 8. Supply Current versus Ambient Temperature

Figure 9. Output Voltage Swing versus Supply Voltage

Figure 10. Slew Rate versus Set Current

Figure 11. Input Noise Voltage versus Set Current

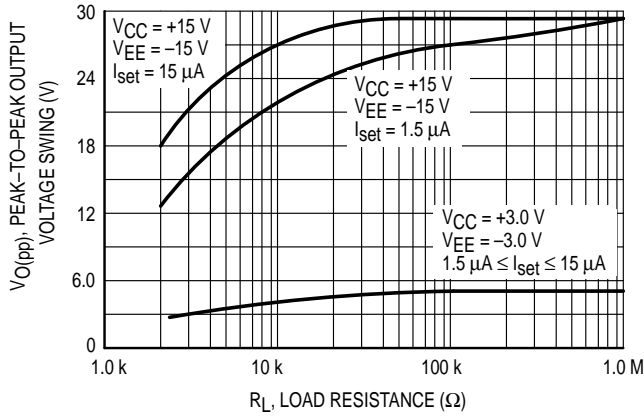
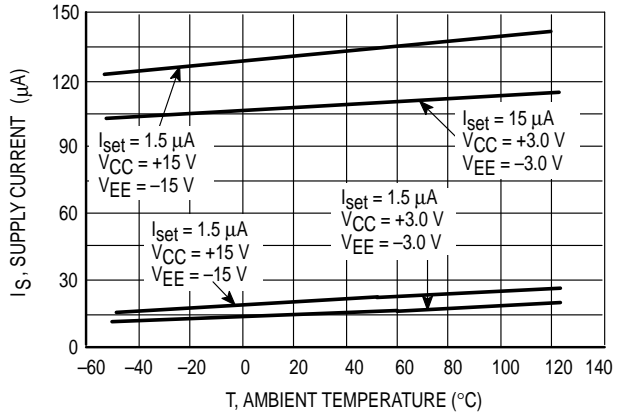
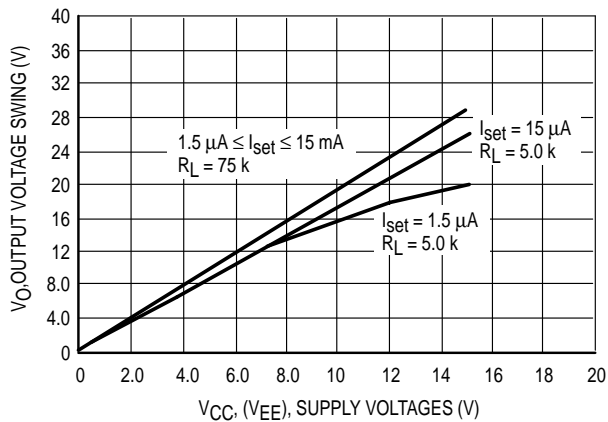
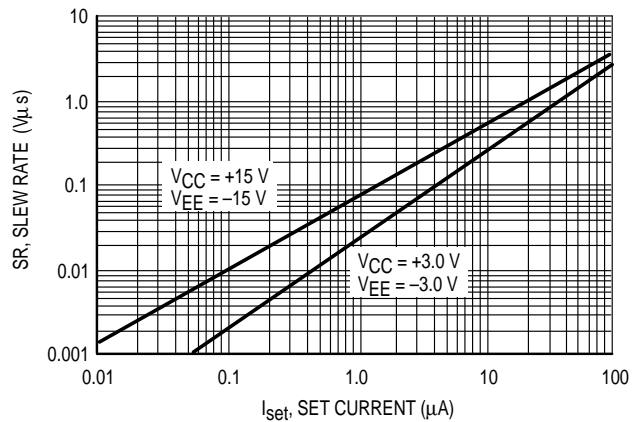
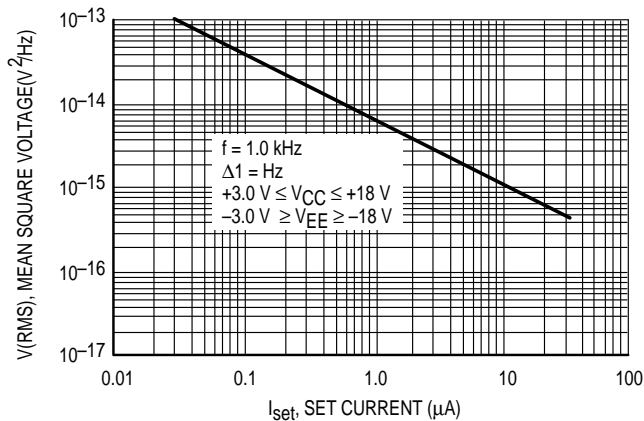
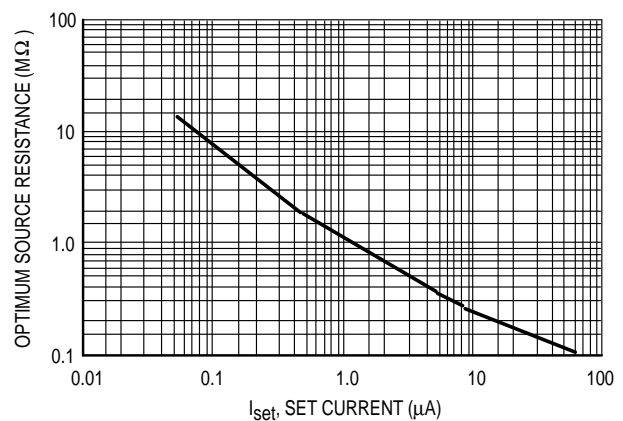
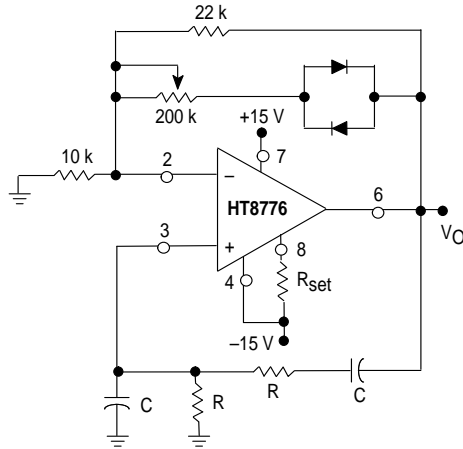
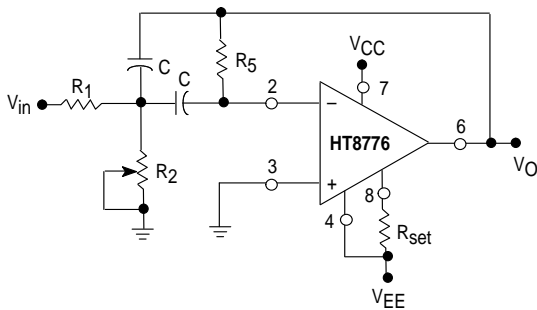
Figure 12. Optimum Source Resistance for Minimum Noise versus Set Current

Figure 13. Wien Bridge Oscillator

$$f_0 = \frac{1}{2\pi RC} \quad (\text{for } f_0 = 1.0 \text{ kHz})$$

$$R = 16 \text{ k}\Omega$$

$$C = 0.01 \mu\text{F}$$

Figure 14. Multiple Feedback Bandpass Filter

For a given:

f_0 = center frequency
 $A(f_0)$ = Gain at center frequency
 Q = quality factor

Choose a value for C, then

$$R_5 = \frac{Q}{\pi f_0 C}$$

$$R_1 = \frac{R_5}{2A(f_0)}$$

$$R_2 = \frac{R_1 R_5}{4Q^2 R_1 - R_5}$$

To obtain less than 10% error from the operational amplifier:

$$\frac{Q_0 f_0}{\text{GBW}} \leq 0.1$$

where f_0 and GBW are expressed in Hz. GBW is available from Figure 6 as a function of Set Current, I_{set} .

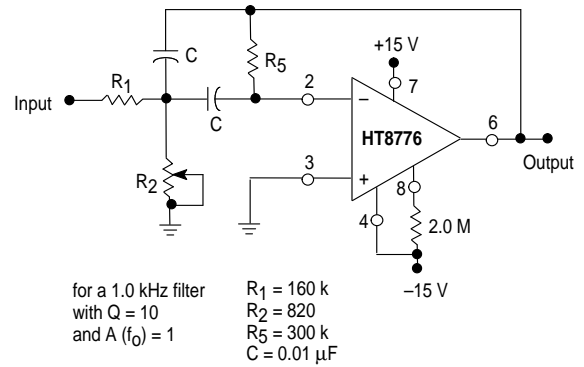
Figure 15. Multiple Feedback Bandpass Filter (1.0 kHz)

for a 1.0 kHz filter
 with $Q = 10$
 and $A(f_0) = 1$

$$R_1 = 160 \text{ k}$$

$$R_2 = 820$$

$$R_5 = 300 \text{ k}$$

$$C = 0.01 \mu\text{F}$$

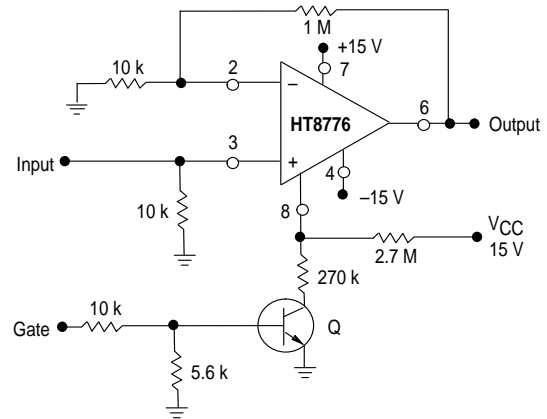
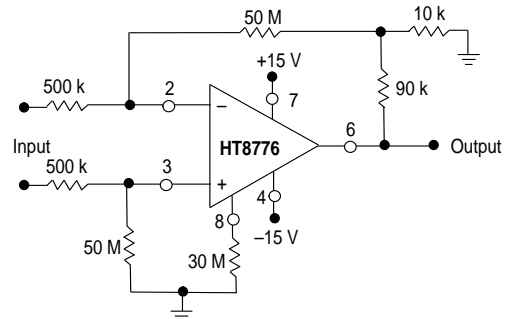
Figure 16. Gated Amplifier

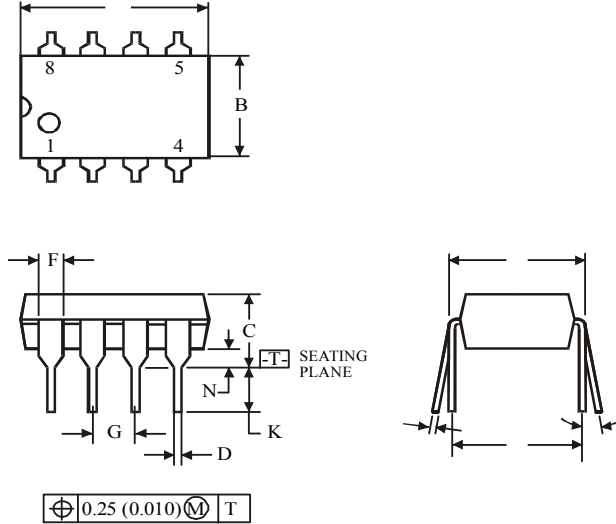
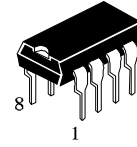
Figure 17. High Input Impedance Amplifier

(DIP8)

NOTES:

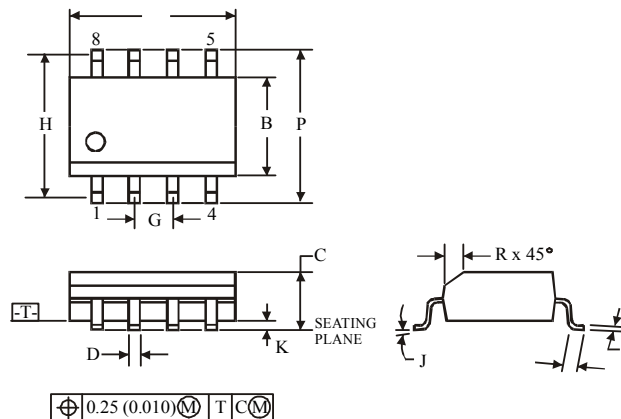
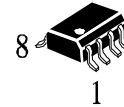
- Dimensions "A", "B" do not include mold flash or protrusions.
Maximum mold flash or protrusions 0.25 mm (0.010) per side.

Symbol	Dimension, mm	
	MIN	MAX
A	8.51	10.16
B	6.1	7.11
C		5.33
D	0.36	0.56
F	1.14	1.78
G	2.54	
H	7.62	
J	0°	10°
K	2.92	3.81
L	7.62	8.26
M	0.2	0.36
N	0.38	

(SOP8)

NOTES:

- Dimensions A and B do not include mold flash or protrusion.
- Maximum mold flash or protrusion 0.15 mm (0.006) per side for A; for B - 0.25 mm (0.010) per side.

Symbol	Dimension, mm	
	MIN	MAX
A	4.8	5
B	3.8	4
C	1.35	1.75
D	0.33	0.51
F	0.4	1.27
G	1.27	
H	5.72	
J	0°	8°
K	0.1	0.25
M	0.19	0.25
P	5.8	6.2
R	0.25	0.5