

5V 1A三相无感正弦波电机驱动

5V, 1A Three-Phase Sensor-Less Sine-wave Motor Driver

■ FEATURES

- Power Supply: 2V~6V
- Output Current: 1A peak; 0.4A average
- Three-Phase, Sensor-Less, PWM Sine-Wave Driver
- Adjustable Startup Commutation Time
- External PWM or VSP Speed Control
- Quick Start Function
- FG, 1/2FG or RD Output
- Power Saving Function
- Lock Protection, Auto Restart Function, Over Temperature Shutdown Protection
- VCC电压: 2~6V
- 输出电流: 1A峰值, 0.4A均值
- 三相、无感、PWM正弦波驱动
- 启动换向时间可调
- 外部PWM或VSP速率控制
- 快速启动功能
- FG, 1/2FG或RD输出
- 支持节能功能
- 锁定保护、自动重启功能、过温关断保护功能

■ APPLICATIONS

- Silent fans
- Variable Speed Control Fans
- 静音风扇
- 变速风扇

■ DESCRIPTION

The HTD9300 is a sensor-less, PWM sine-wave driver for three-phase brushless DC motor.

A sine-wave method usually delivers a more silent driving.

The device include start-up circuit, back-EMF commutation control, PWM speed control, voltage speed control, lock protection, and over temperature shutdown protection circuit.

The device can be widely used in applications with silent fans driving demand, such as CPU coolers and game machines.

The device is available in DFN3x3-10L package with lead free.

HTD9300是一款用于三相无刷直流电机的无传感器 PWM 正弦波驱动器。

正弦波方式通常能带来更安静的驱动。

该器件集成了启动电路、反电动势检测、PWM速度控制、电压速度控制、锁定保护和过温关断保护电路。

该器件可广泛用于有静音风扇驱动需求的应用, 例如CPU散热器和游戏机。

该器件采用无铅 DFN3x3-10L 封装。

■ ORDERING INFORMATION

Part Number	Package Type	Shipping Package / MOQ
HTD9300DNE	DFN3x3-10L	Taping, 5000 pcs/reel



TYPICAL APPLICATION

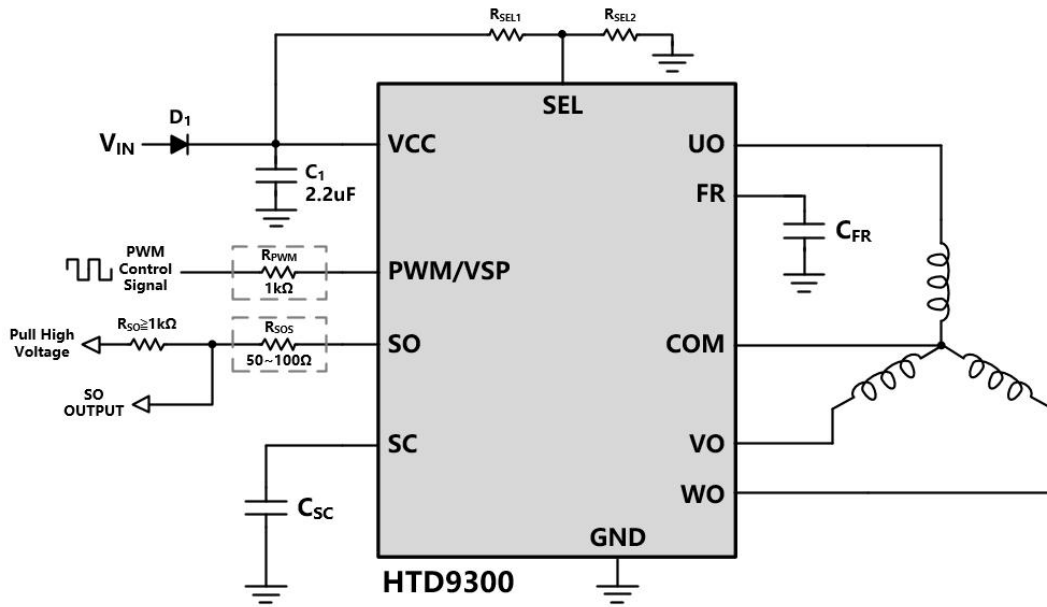

Note: 1. R_{PWM} and R_{SOS} are optional to protect internal circuit for abnormal voltage stress.
2. C_{FR} is to set the time of reverse rotation after every power on.

Figure 1 Application Example of PWM Speed Control

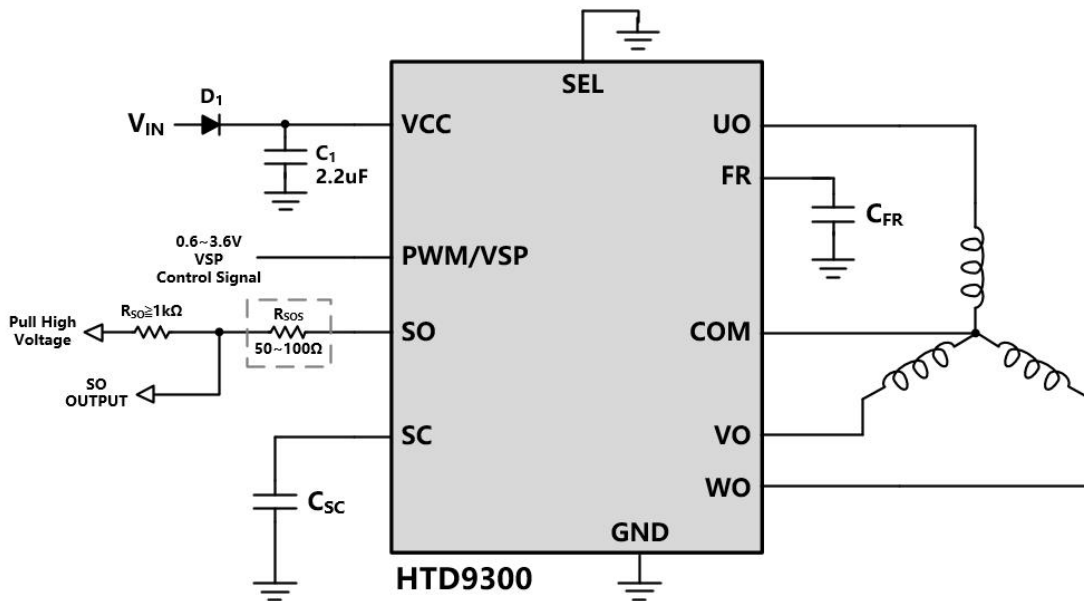

Note: 1. R_{SOS} is optional to protect internal circuit for abnormal voltage stress.
2. C_{FR} is to set the time of reverse rotation after every power on.

Figure 2 Application Example of VSP Speed Control

■ TERMINAL CONFIGURATION

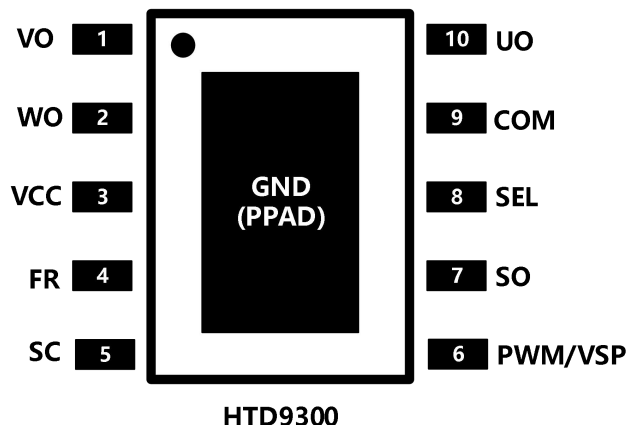

■ TERMINAL FUNCTION

Terminal No. 管脚编号	Name 管脚名	Function 功能说明
1	VO	Driver output signal for motor phase V 驱动输出，接电机V相
2	WO	Driver output signal for motor phase W. 驱动输出，接电机W相
3	VCC	Power supply. 电源。
4	FR	Motor rotating direction control. 电机转动方向控制 FR=VCC: U-> V -> W FR=GND: U -> W ->V Connect a capacitor to GND: U -> W -> V after T _{FR} (time of reverse rotation after power on) 接电容到地时，启动后经T _{FR} 的反转后，U -> W -> V
5	SC	Start-up commutation time setting. Connect a capacitor to GND to set start-up commutation time. 启动换向时间设置。接电容到地设置建立时间。
6	PWM/VSP	PWM or VSP signal input, to control rotation speed. PWM/VSP输入，控制转速
7	SO	Rotation speed output or rotation detection output, open drain. 转速监测输出，开漏结构
8	SEL	Mode Setting. Use a voltage divider from VCC to set SEL pin voltage for setting. 模式设置，VCC分压可设置不同模式
9	COM	Motor Neutral Point Input 接电机中间抽头端子
10	UO	Driver Output signal for motor phase U. 驱动输出，接电机U相
PPAD	GND	Ground. 地

SPECIFICATIONS¹
Absolute Maximum Ratings at $T_A = 25^\circ\text{C}$ ²

PARAMETER	Symbol	MIN	TYP	MAX	UNIT
Power Supply	VCC	-0.3		7	V
UO, VO, WO Output Current	I _{OUT}		1		A
UO, VO, WO Output Voltage	V _{OUT}	-0.3		7	V
SO Output Voltage	V _{SO}	-0.3		7	V
SO Sink Current	I _{SO}			10	mA
PWM/VSP, FR Input Voltage	V _{IN}	-0.3		7	V
Sense Voltage	V _{SENSE}	-0.3		0.5	V
Maximum Junction Temperature	T _{J(max)}	-40		150	°C
Storage Temperature	T _{stg}	-55		150	°C
Maximum Lead Soldering Temperature (10 Seconds)	T _{SDR}			260	°C

Thermal Information

PARAMETER	Symbol	DFN3×3	UNIT
Junction-to-ambient thermal resistance ³	R _{θJA}	120	°C/W

Recommended Operating Conditions

PARAMETER	Symbol	CONDITION	MIN	TYP	MAX	UNIT
Power Supply	VCC		2	-	6	V
PWM/VSP Input Voltage	V _{IN_PWM/VSP}		0	-	VCC	V
Working Temperature	T _A		-40	-	105	°C
UO, VO, WO Average Output Current	I _{OUT}		0	-	0.4	A

Electrical Characteristics at $T_A = 25^\circ\text{C}$, VCC = 5 V

PARAMETER	Symbol	CONDITION	MIN	TYP	MAX	UNIT
Supply Current						
Working current	I _{CC}	Rotating	-	3	5	mA
Standby current	I _{Standby}	Standby (PWM = 0)	-	100	150	uA
PWM Input						
Low voltage	V _{IL}		-0.3	-	0.8	V
High voltage	V _{IH}		2.5	-	VCC+0.3	V
Input current_low level	I _{IL}	PWM = GND	-	0	-	uA
Input current_high level	I _{IH}	PWM = VCC	-	-10	-	uA
Input frequency	f _{PWM}		2	-	50	kHz
Output switch frequency	f _{OUT}		26	31	36	kHz
Output Drivers						
Saturation Voltage	V _O	I _O = 0.25A, upper and lower total	-	0.3	0.45	V
SO Low Voltage	V _{OL_SO}	I _{SO} = 5mA	-	0.1	0.3	V
SO Leakage Current	I _{LK_SO}	V _{SO} = 5V	-	<0.1	1	uA
Oscillator						
SC High Level Voltage	V _{H_SC}		1	1.2	1.4	V
SC Low Level Voltage	V _{L_SC}		0.5	0.6	0.7	V
SC Charge Current	I _{CH_SC}	V _{SC} =0V	-	15	-	uA
SC Discharge Current	I _{DCH_SC}	V _{SC} =1.2V	-	15	-	uA
FR High Level Voltage	V _{H_FR}		1	1.2	1.4	V

¹ Depending on parts and PCB layout, characteristics may be changed.

² Stresses beyond those listed under absolute maximum ratings may cause permanent damage to the device. These are stress ratings only, and functional operation of the device at these or any other conditions beyond those indicated under recommended operating conditions is not implied. Exposure to absolute-maximum-rated conditions for extended periods may affect device reliability.

³ It is obtained by test on a JEDEC standard high-K board specified in JESD51-7 under environmental conditions described in JESD51-2a.

FR Low Level Voltage	V_{L_FR}		0.5	0.6	0.7	V
FR Charge Current	I_{CH_FR}	$V_{FR}=0V$	-	5	-	uA
FR Discharge Current	I_{DCH_FR}	$V_{FR}=1.2V$	-	5	-	uA
FR						
FR High Level Voltage	V_{FRH}		2.5	-	VCC	V
FR Low Level Voltage	V_{FRL}		0	-	0.8	V
ZC Comparator						
Floating Node Zero Crossing Hysteresis	V_{ZC}		1	7	15	mV
Quick Start						
Quick Start Enable Time	t_{QS}		-	10	-	ms
Protection Circuit						
Lock protection detection on time	I_{ON_Lock}		0.705	0.75	0.795	s
Lock protection detection off time	I_{OFF_Lock}		4.25	5	5.75	s
Over temperature shutdown threshold	T_{SD}	Junction temperature	-	150	-	°C
Over temperature shutdown hysteresis	T_{HYS}		-	30	-	°C

APPLICATION INFORMATION

1 Block Diagram

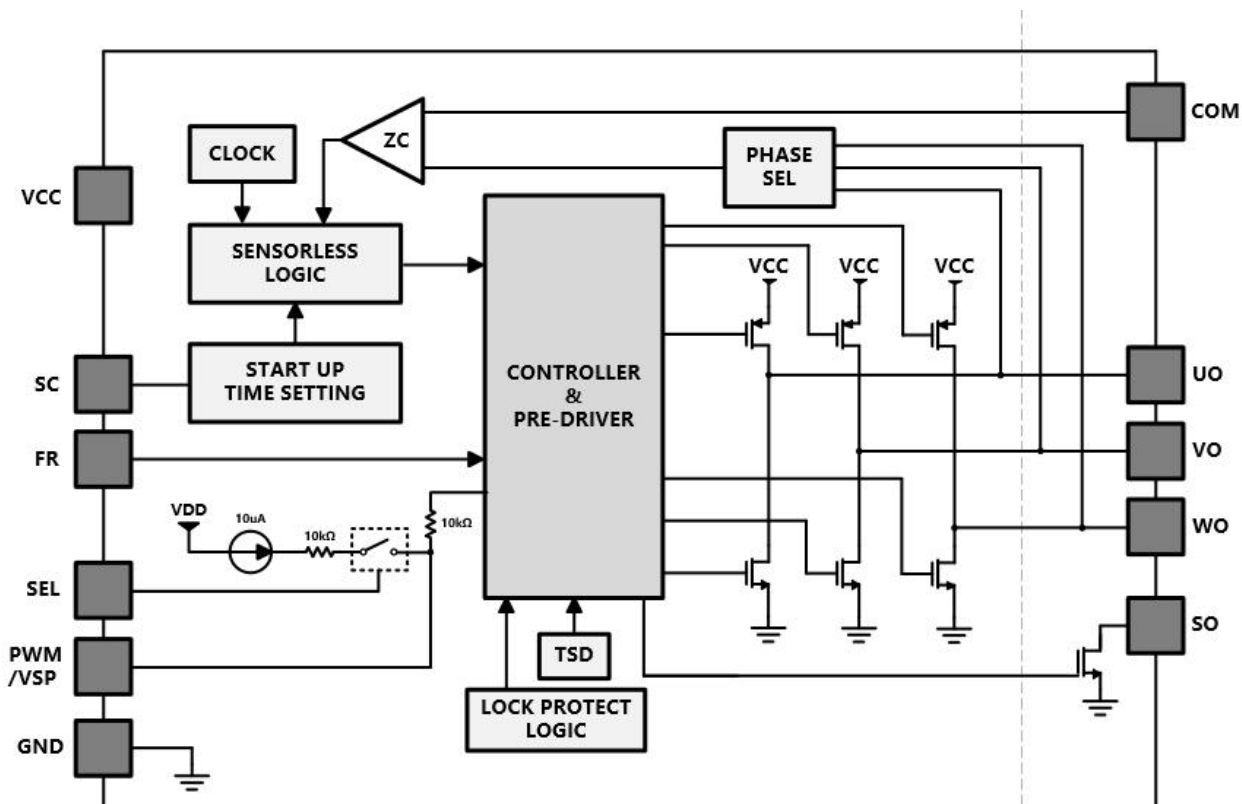

Figure 3 Block Diagram

2 PWM Speed Control (fixed output frequency)

The rotation speed of the motor can be controlled by the duty cycle of input PWM. The output PWM frequency is fixed to 31kHz typically.

3 VSP Speed Control

When SEL is pulled to GND, the VSP input voltage can directly control the output PWM duty cycle so that the rotation speed of the motor can be adjusted.

电机的转速可通过输入 PWM 的占空比调节。输出 PWM 频率为固定的 31kHz (典型值)。

当 SEL 被拉到 GND 时, VSP 输入电压可以直接控制输出 PWM 占空比, 从而可以调节电机的转速。

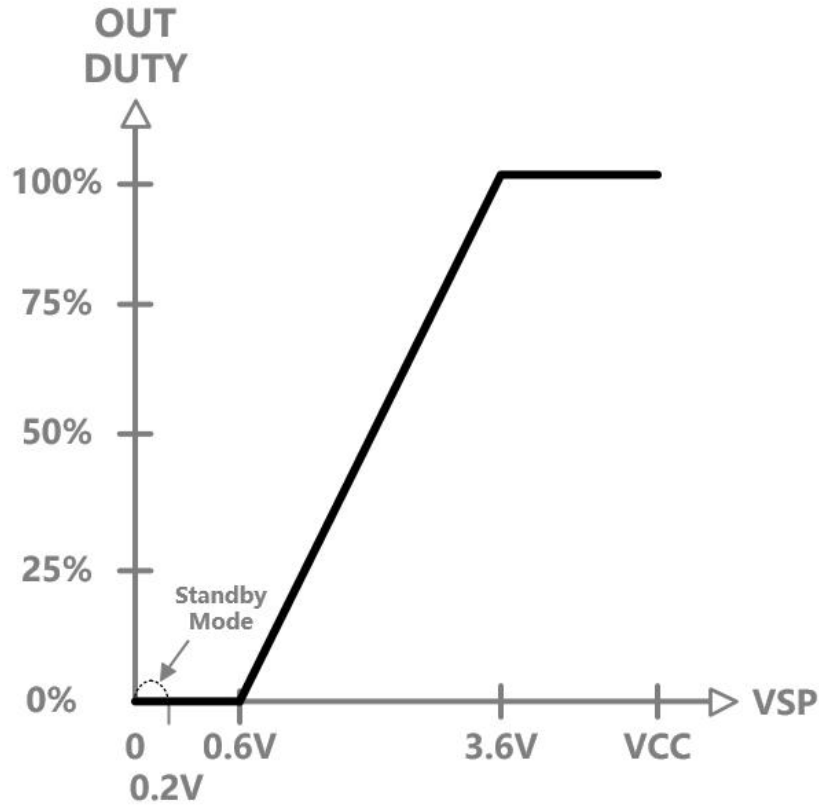

Figure 4 VSP Control

4 Sine-Wave Switch Control

A sine-wave switch control is a soft PWM duty-cycle control to simulate a sine wave output current, it can make the phase current smoother and reduce the noise of motor rotation.

正弦波开关控制是一种 PWM 占空比控制，用于模拟正弦波输出电流，它可以使相电流更平滑，降低电机旋转的噪音。

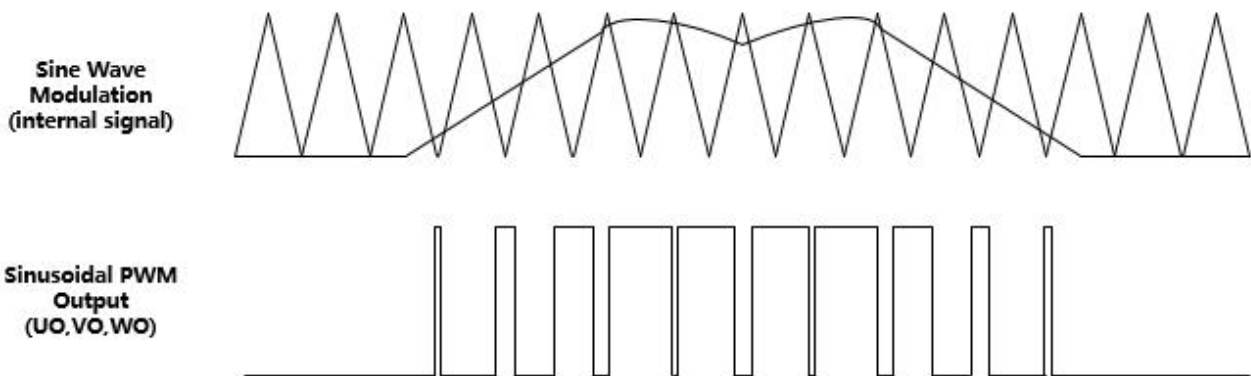

Figure 5 Sine-Wave Switch Control

5 Quick Start and Standby Mode

The device will enter into standby mode once the PWM input keeps low level for more than 10ms (typ.). In standby mode, the supply current is around 100uA and the lock protection function doesn't work, therefore, the fan will directly work without delay when releasing standby mode.

一旦 PWM 输入保持低电平超过 10ms (典型值), 器件将进入待机模式。在待机模式下, 电源电流约为 100uA, 锁定保护功能不起作用, 因此, 在解除待机模式时, 风扇可不经延时直接启动。

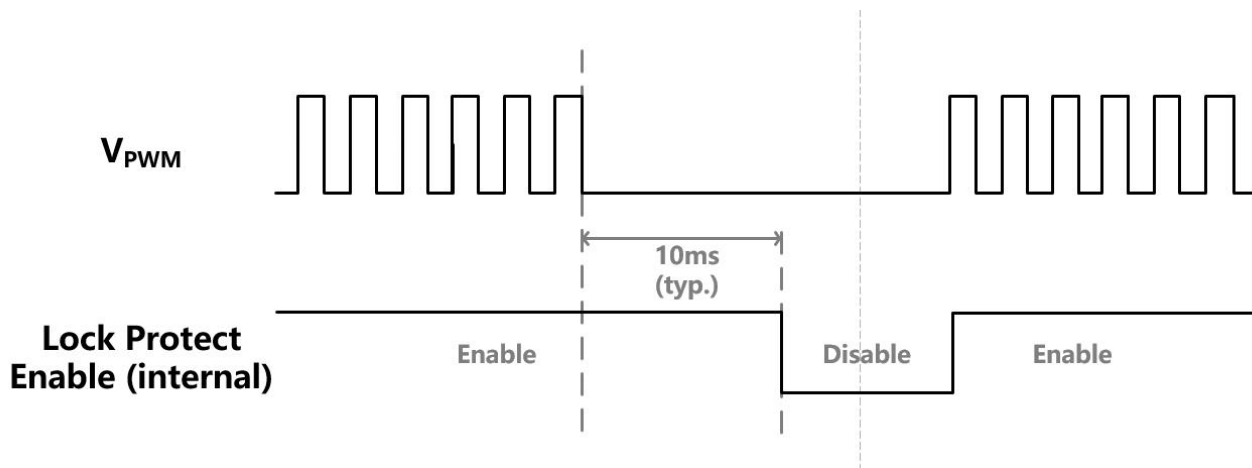

Figure 6 Quick Start Timing

6 Reverse Rotation Time Setting (FR Terminal)

Every time when power on, there is a period time of reverse rotation before normal forward operation. This period time of reverse rotation can be adjusted by the external capacitor between FR and GND.

每次上电时, 在正常工作之前, 都有一段时间的反向转动。反向转动时间可以通过 FR 和 GND 之间的外部电容来调节。

$$t_{FR} = \frac{2 \times C_{FR} \times (V_{H_FR} - V_{L_FR})}{I_{CH_FR}} \times 12000$$

If $C_{FR} = 10\text{nF}$, $V_{H_FR} = 1.2\text{V}$, $V_{L_FR} = 0.6\text{V}$, $I_{CH_FR} = 5\mu\text{A}$, $t_{FR} = 28.8\text{s}$

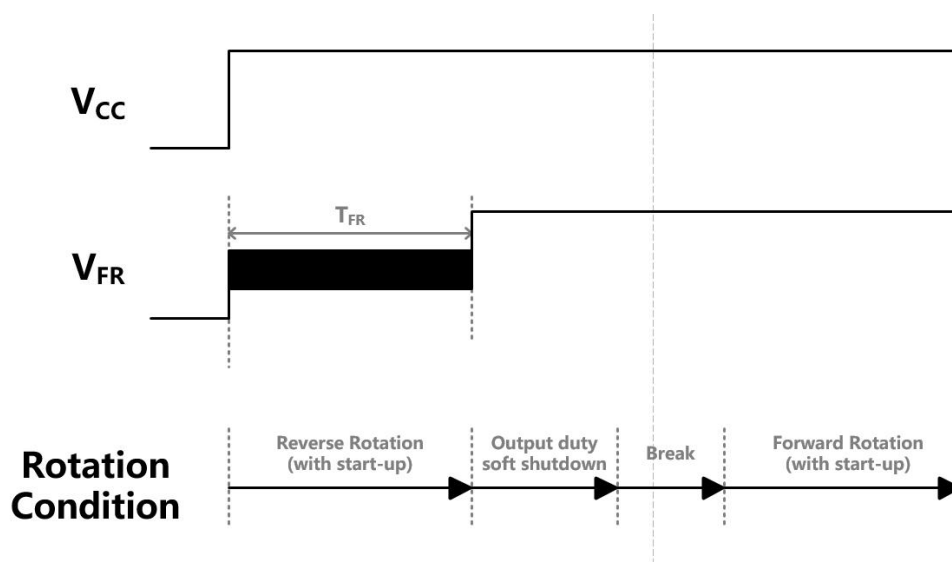

Figure 7 Reverse Rotation Timing

7 Mode Setting

Using a voltage divider from VCC to set SEL terminal voltage can set the device into different mode.

使用 VCC 的分压器设置 SEL 端电压，可以设置器件进入不同的模式。

Table 1 H-bridge Control Logic Table

SEL voltage	R _{UP}	R _{DN}	SO Output	Speed Control
GND	Open	Short	FG	VSP
0.2V ~ 0.4VCC	30kΩ	10kΩ	RD	PWM
0.4VCC ~ 0.8VCC	10kΩ	15kΩ	1/2FG	PWM
VCC	Short	Open	FG	PWM

8 SO Output

Open-drain output. Connecting a pullup resistor (R_{SO}) to a high level voltage for the speed detection function. During the lock state, the SO will always high (switch off). Leave it float when not in use. The value of R_{SO} is recommended between 1kohm to 10kohm.

开漏输出。使用上拉电阻(R_{SO})连接到高电平，以实现速度检测功能。在锁定状态下，SO 将始终为高电平（关闭）。不使用时可悬空。R_{SO} 建议使用 1~10kohm。

$$R_{SO} = \frac{VCC - V_{OL_SO}}{I_{SO}}$$

If VCC = 5V, I_{SO} = 5mA, V_{OL_SO} = 0.1V, R_{SO} = 0.98kohm

9 SC Capacitor

The capacitor (C_{SC}) connected between SC and GND can determine startup commutation time. A optimal time make the motor startup in succeed. The value of C_{SC} is recommended between 1nF to 10nF.

连接在 SC 和 GND 之间的电容 (C_{SC}) 可以设置启动建立时间。合理的时间促成电机启动成功。建议 C_{SC} 的值在 1nF 到 10nF 之间。

10 Power Supply

It is necessary to add a protection diode (D1) to prevent the damage from the power reverse connection. However, the diode will cause a voltage drop. The current rating of the diode must be larger than the maximum output current.

为防止电源反接造成的损坏，可以在电源端增加一个保护二极管 (D1)。但二极管会产生压降。二极管的额定电流必须大于最大输出电流。

A capacitor (C1) should be placed as close as possible between VCC and GND to reduce power noise..

为了降低电源波动，在 VCC 和 GND 之间连接一个电容器 (C1)，并尽量靠近引脚。

11 Lock Protection and Automatic Restart

Once the motor is locked, the device will enter into lock protection mode after 0.75s to turn off output driver for 5s. After lock protection mode, the device switches to startup operation again for 0.75s. This lock-and-startup process will be recurred until the lock state is released.

一旦电机被锁定，设备将在 0.75s 后进入锁定保护模式，关闭输出驱动器 5s。此后，器件再次切换到启动操作，持续 0.75 秒。此锁定和启动过程将重复，直到锁定状态消失。

12 Over Temperature Shutdown Protection

When internal junction temperature reaches 150 °C , the output driver will be switched off. When the junction temperature lowers down 30°C, the output driver will restart.

当内部结温达到 150° C 时,输出驱动器将关断。
当结温降低 30° C 时,输出驱动器将重新启动。。

PACKAGE OUTLINE

DFN3×3-10L

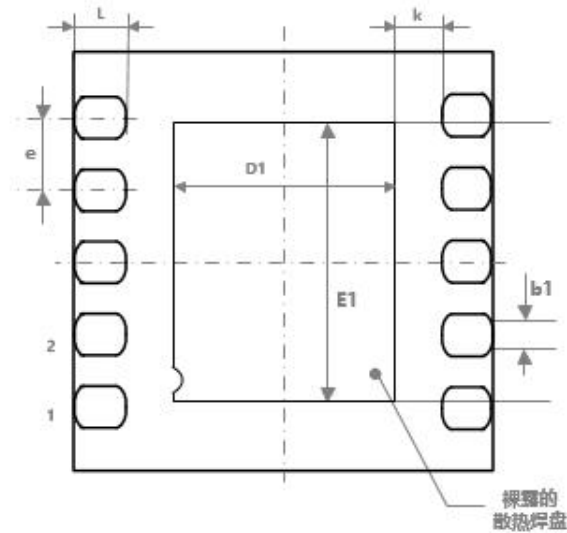
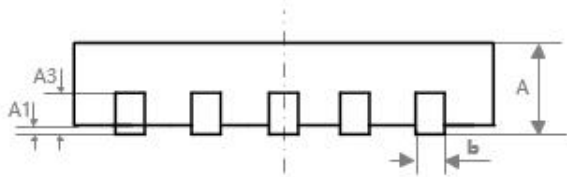

Top View

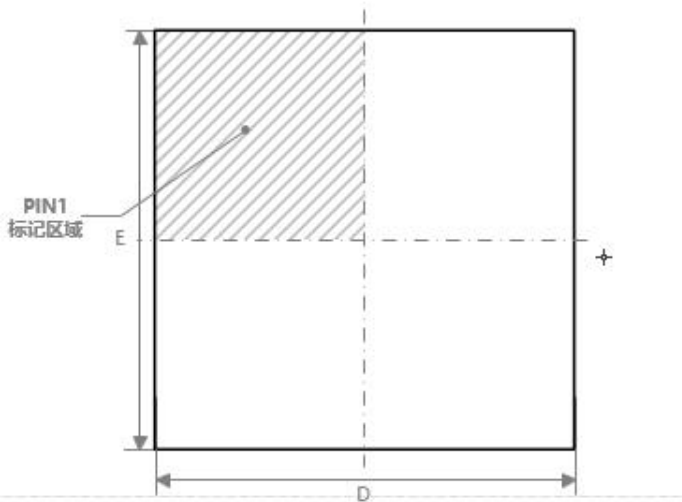

Symbol	Millimeter (mm)		
	MIN	TYP	MAX
A	0.700	-	0.800
A1	0.000	-	0.050
A3	0.203REF		
b	0.200	-	0.300
b1	0.180REF		
D	2.924	-	3.076
D1	1.600	-	1.800
E	2.924	-	3.076
E1	2.300	-	2.500
e	0.500(BSC)		
k	0.250REF		
L	0.324	-	0.476

TAPE AND REEL INFORMATION

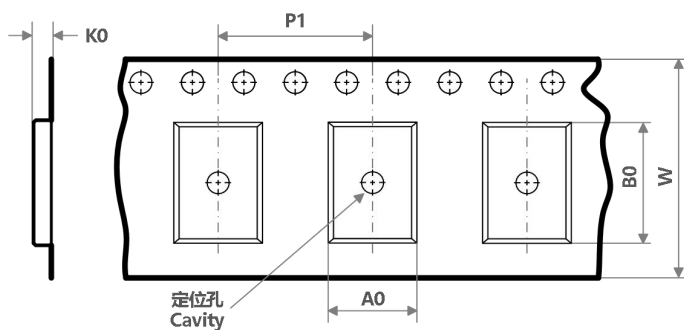
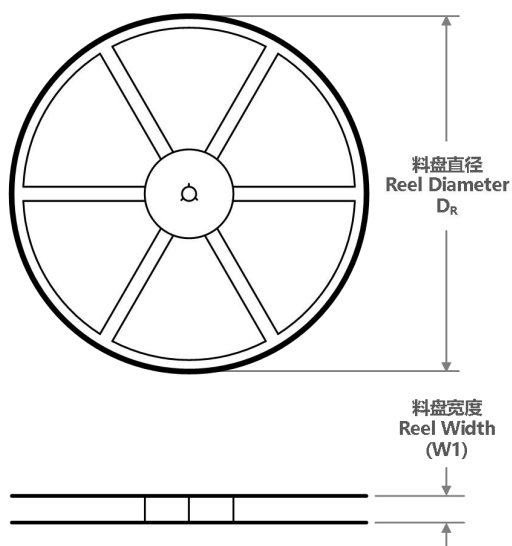

A0	Dimension designed to accommodate the component width; 料槽宽度
B0	Dimension designed to accommodate the component length; 料槽长度
K0	Dimension designed to accommodate the component thickness; 料槽厚度
W	Overall width of the carrier tape; 载带整体宽度
P1	Pitch between successive cavity centers; 相邻槽中心间距

编带 PIN1 方位象限分配
Quadrant Assignments for Pin1 Orientation in Tape

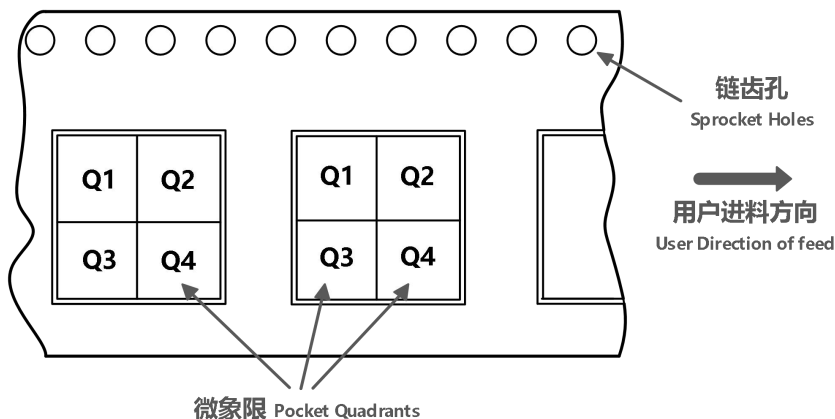

器件料号 Part No.	封装类型 Package Type	封装标识 Package Code	引脚数 Pins	SPQ	料盘直径 D_R (mm)	料盘宽度 $W1$ (mm)	A0 (mm)	B0 (mm)	K0 (mm)	P1 (mm)	W (mm)	Pin1 象限 Quadrant
HTD9300DNE	DFN	DNE	10	5000	330	12	3.3	3.3	1.05	8	12	Q2

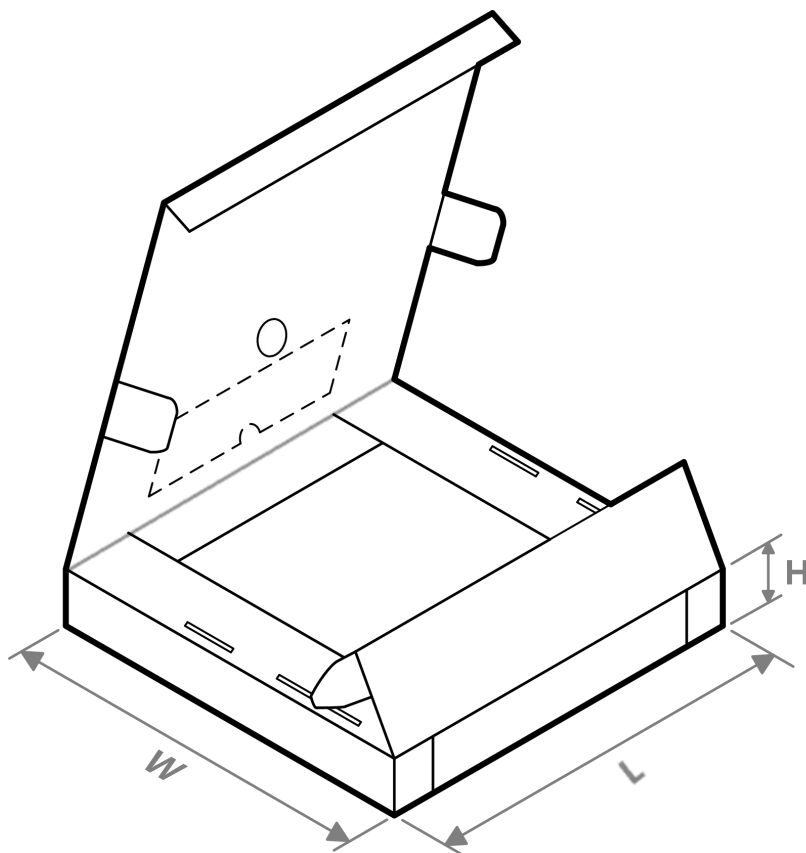
TAPE AND REEL BOX INFORMATION

器件料号 Part No.	封装类型 Package Type	封装标识 Package Code	引脚数 Pins	SPQ	长度 Length (mm)	宽度 Width (mm)	高度 Height (mm)
HTD9300DNE	DFN	DNE	10	5000	360	345	50

IMPORTANT NOTICE**注意**

Heroic Electronic Technology (Jiaxing) Co., Ltd (HT) reserves the right to make corrections, modifications, enhancements, improvements, and other changes to its products and services at any time and to discontinue any products or services. Customers should obtain the latest relevant information before placing orders and should verify that such information is current and complete.

禾润电子科技（嘉兴）股份有限公司（以下简称HT）保留对产品、服务、文档的任何修改、更正、提高、改善和其他改变，或停止提供任何产品和服务的权利。客户在下单和生产前应确保所得到的信息是最新、最完整的。

HT assumes no liability for applications assistance or customer product design. Customers are responsible for their products and applications using HT components.

HT对相关应用的说明和协助以及客户产品的板级设计不承担任何责任。

HT products are not authorized for use in safety-critical applications (such as life support devices or systems) where a failure of the HT product would reasonably be expected to affect the safety or effectiveness of that devices or systems.

HT的产品并未授权用于诸如生命维持设备等安全性极高的应用中。

The information included herein is believed to be accurate and reliable. However, HT assumes no responsibility for its use; nor for any infringement of patents or other rights of third parties which may result from its use.

本文中的相关信息是精确和可靠的，但HT并不对其负责，也不对任何可能的专利和第三方权利的侵害负责。

Following are URLs and contacts where you can obtain information or supports on any HT products and application solutions:

下面是可以联系到我公司的相关链接和联系方式：

禾润电子科技（嘉兴）股份有限公司
Heroic Electronic Technology (Jiaxing) Co., Ltd.

地址：浙江省嘉兴市凌公塘路3339号JRC大厦A座三层

Add: A 3rd floor, JRC Building, No. 3339, LingGongTang Road, Jiaxing, Zhejiang Province

Sales: 0573-82585539, sales@heroic.com.cn

Support: 0573-82586151, support@heroic.com.cn

Fax: 0573-82585078

Website: www.heroic.com.cn; wap.heroic.com.cn

Wechat MP: HEROIC_JX

请及时关注禾润官方微信公众号，随时获取最新产品信息和技术资料！

