

## Current Transducer HTFS 200 ... 800-P

For the electronic measurement of currents: DC, AC, pulsed..., with galvanic separation between the primary circuit and the secondary circuit.



All data are given with  $R_L = 10 \text{ k}\Omega$

$$I_{PN} = 200 \dots 800 \text{ A}$$



### Electrical data

Primary nominal RMS current $I_{PN} \text{ (A)}$	Primary current measuring range $I_p \text{ (A)}$	Type
200	$\pm 300$	<b>HTFS 200-P</b>
400	$\pm 600$	<b>HTFS 400-P</b>
600	$\pm 900$	<b>HTFS 600-P</b>
800	$\pm 1200$	<b>HTFS 800-P</b>

$U_{out}$	Output voltage (Analog) @ $I_p$	$U_{ref} \pm (1.25 \cdot I_p / I_{PN})$	V
	$I_p = 0$	$U_{ref} \pm 0.025$	V
$U_{ref}$	Reference voltage	$1/2 U_C \pm 0.025$	V
	$U_{ref}$ Output impedance	Typ. 200	$\Omega$
	$U_{ref}$ Load impedance	$\geq 200$	k $\Omega$
$R_L$	Load resistance	$\geq 2$	k $\Omega$
$R_{out}$	Output internal resistance	$< 5$	$\Omega$
$C_L$	Capacitive loading	4.7	nF
$U_C$	Supply voltage ( $\pm 5 \%$ )	5	V
$I_C$	Current consumption @ $U_C = 5 \text{ V}$	19 (typ) 25 (max)	mA mA

### Accuracy - Dynamic performance data

$\epsilon_{tot}$	Total error <sup>2)</sup> @ $I_{PN}, T_A = 25 \text{ }^\circ\text{C}$	$\leq \pm 1$	%
$\epsilon_L$	Linearity error 0 ... $1.5 \times I_{PN}$	$\leq \pm 0.5$	%
$TCU_{OE}$	Temperature of coefficient of $U_{OE}$ @ $I_p = 0$ ,	$\leq \pm 0.1$	mV/K
$TCU_{ref}$	Temperature of coefficient of $U_{ref}$	$\leq \pm 190$	ppm/K
$TCU_{out}$	Temperature of coefficient of $U_{out}$	$\leq \pm 420$	ppm/K
$U_{OM}$	Magnetic offset voltage @ $I_p = 0$ and specified $R_M$ , after an overload of $3 \times I_{PNDC}$	$< \pm 0.5$	%
$u_{no}$	Output voltage noise (DC ... 20 MHz)	$< 40$	mVpp
$t_{D10}$	Delay time to 10 % of the final output value for $I_{PN}$ step	$< 2$	$\mu\text{s}$
$t_{D90}$	Delay time to 90 % of the final output value for $I_{PN}$ step	$< 3.5$	$\mu\text{s}$
$di/dt$	$di/dt$ accurately followed	$> 100$	A/ $\mu\text{s}$
$BW$	Frequency bandwidth ( $-3 \text{ dB}$ ) <sup>3)</sup>	DC ... 240	kHz

**Notes:** <sup>1)</sup> It is possible to overdrive  $U_{ref}$  with an external reference voltage between 0.5 – 2.65 V

<sup>2)</sup> Excluding offset and magnetic offset voltage

<sup>3)</sup> Small signal only to avoid excessive heatings of the magnetic core.

### Features

- Hall effect measuring principle
- Galvanic separation between primary and secondary circuit
- Low power consumption
- Single power supply +5 V
- Ratiometric offset
- Insulating plastic case recognized according to UL 94-V0
- Fastening by M3 nuts and screws
- $T_A = -40 \text{ }^\circ\text{C} \dots +105 \text{ }^\circ\text{C}$ .

### Advantages

- Small size and space saving
- Only one design for wide current ratings range
- High immunity to external interference
- $U_{ref}$  IN/OUT.

### Applications

- Forklift drives
- AC variable speed drives
- Static converters for DC motor drives
- Battery supplied applications
- Uninterruptible Power Supplies (UPS)
- Switched Mode Power Supplies (SMPS)
- Power supplies for welding applications.

### Application domain

- Industrial.

## Current Transducer HTFS 200 ... 800-P

### General data

$T_A$	Ambient operating temperature	-40 ... +105	°C
$T_{Ast}$	Ambient storage temperature	-40 ... +105	°C
$m$	Mass	60	g
	Standards	EN 50178: 1997	

### Insulation coordination

$U_d$	RMS voltage for AC insulation test, 50 Hz, 1 min	2.5	kV
$U_{Ni}$	Impulse withstand voltage 1.2/50 $\mu$ s	4	kV
$U_e$	Partial discharge extinction RMS voltage @ 10 pC	> 1	kV
		Min	
$d_{Cp}$	Creepage distance	> 4	mm
$d_{Cl}$	Clearance	> 4	mm
$CTI$	Comparative Tracking Index (group IIIa)	> 220	V

### Applications examples

	EN 50178	IEC 61010-1
$d_{Cp}, d_{Cl}, U_{Ni}$	Rated insulation voltage	Nominal voltage
Basic insulation	300 V	300 V
Reinforced insulation	150 V	150 V

According to EN 50178 and IEC 61010-1 standards and following conditions:

- Over voltage category OV 3
- Pollution degree PD2
- Non-uniform field

### Safety

This transducer must be used in limited-energy secondary circuits according to IEC 61010-1.



This transducer must be used in electric/electronic equipment with respect to applicable standards and safety requirements in accordance with the manufacturer's operating instructions.



Caution, risk of electrical shock

When operating the transducer, certain parts of the module can carry hazardous voltage (eg. primary busbar, power supply). Ignoring this warning can lead to injury and/or cause serious damage.

This transducer is a build-in device, whose conducting parts must be inaccessible after installation. A protective housing or additional shield could be used.

Main supply must be able to be disconnected.

### HTFS measuring range with external $U_{ref}$

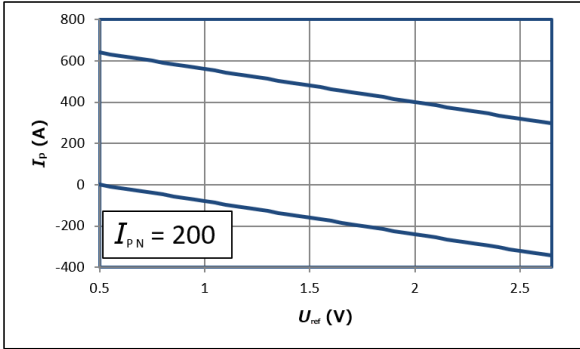

Upper limit:  $I_p = -160 \times U_{ref} + 720$  ( $U_{ref} = 0.5 \dots 2.65$  V)

Lower limit:  $I_p = -160 \times U_{ref} + 80$  ( $U_{ref} = 0.5 \dots 2.65$  V)

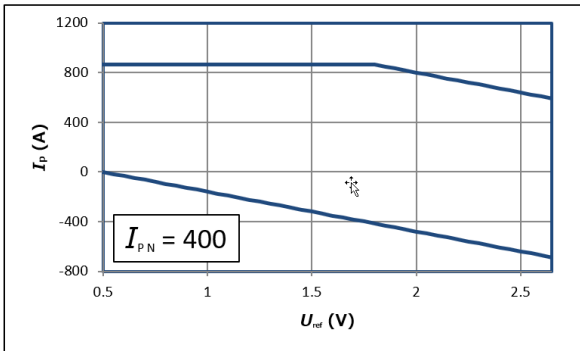

Upper limit:  $I_p = 864$  ( $U_{ref} = 0.5 \dots 1.8$  V)

Upper limit:  $I_p = -320 \times U_{ref} + 1440$  ( $U_{ref} = 1.8 \dots 2.65$  V)

Lower limit:  $I_p = -320 \times U_{ref} + 160$  ( $U_{ref} = 0.5 \dots 2.65$  V)

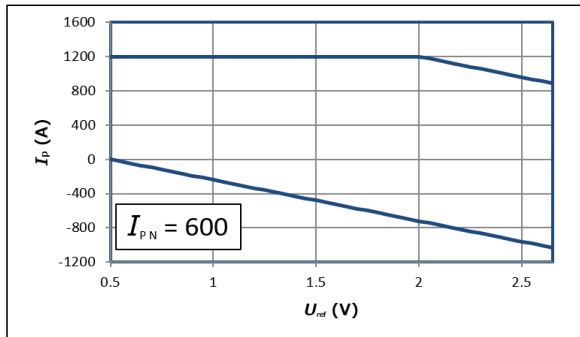

Upper limit:  $I_p = 1200$  ( $U_{ref} = 0.5 \dots 2.0$  V)

Upper limit:  $I_p = -480 \times U_{ref} + 2160$  ( $U_{ref} = 2 \dots 2.65$  V)

Lower limit:  $I_p = -480 \times U_{ref} + 240$  ( $U_{ref} = 0.5 \dots 2.65$  V)

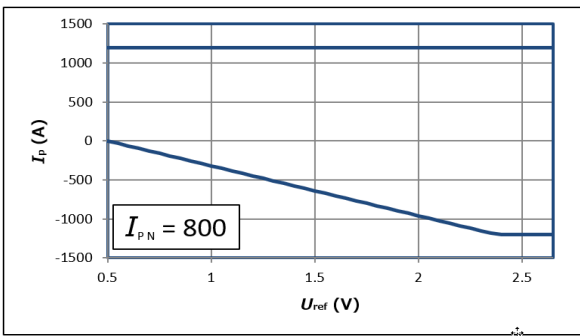

Upper limit:  $I_p = 1200$  ( $U_{ref} = 0.5 \dots 2.625$  V)

Upper limit:  $I_p = -640 \times U_{ref} + 2880$  ( $U_{ref} = 2.625 \dots 2.65$  V)

Lower limit:  $I_p = -640 \times U_{ref} + 320$  ( $U_{ref} = 0.5 \dots 2.4$  V)

Lower limit:  $I_p = -1200$  ( $U_{ref} = 2.4 \dots 2.65$  V)

## Dimensions HTFS 200 ... 800-P (in mm)

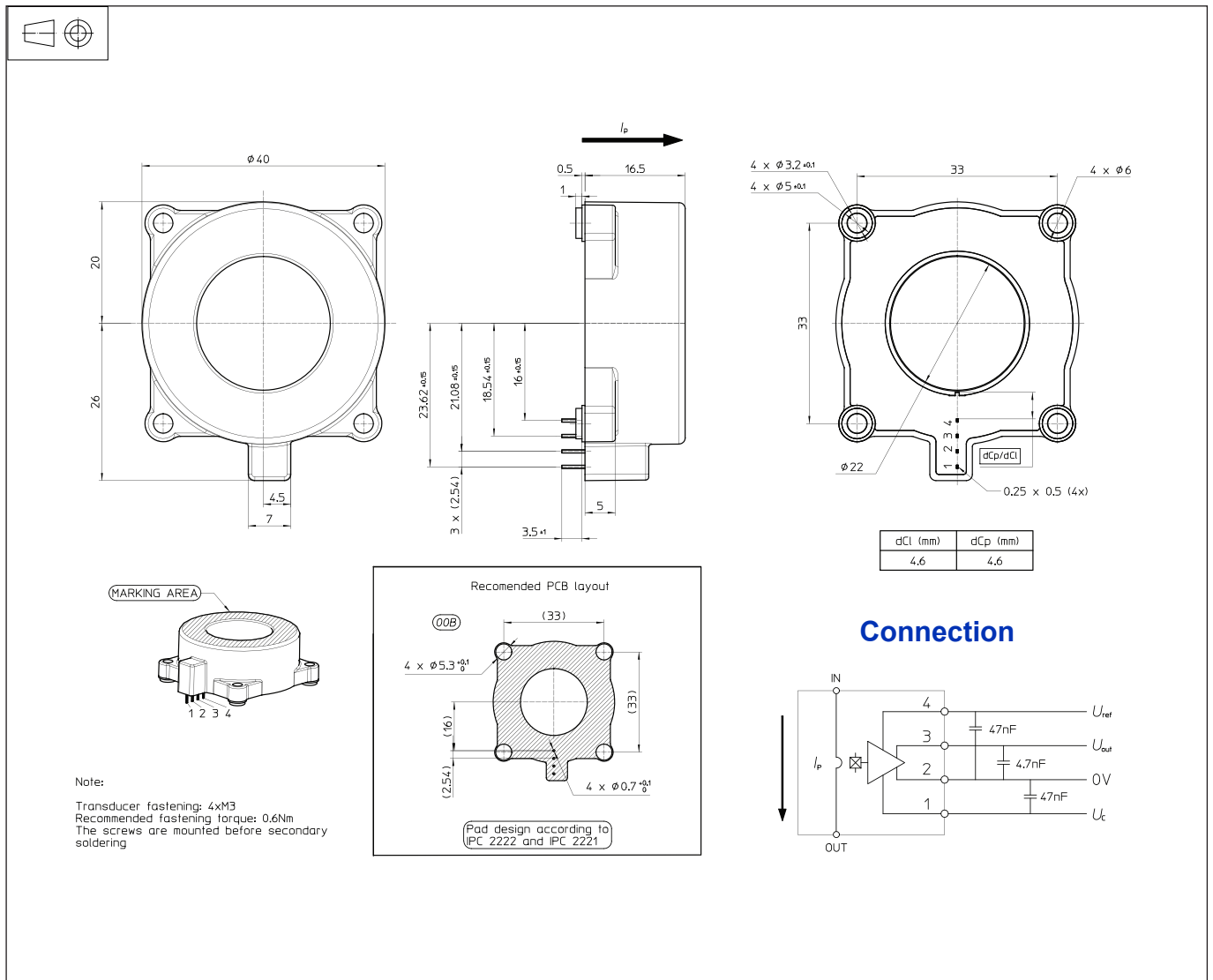

### Mechanical characteristics

- General tolerance:  $\pm 0.2$  mm
- Mounting to PCB: 4 x M3 (not supplied)
- Recommended PCB hole:  $\phi 5,3$  mm
- Fastening torque: 0.6 N m
- Connection to secondary: 4 pins 0.5 x 0.25 mm
- Recommended PCB hole:  $\phi 0.7$  mm

### Remarks

- $U_{out}$  is positive when  $I_p$  flows in the direction of the arrow.
- **Temperature of the primary conductor should not exceed 120 °C.**
- Must be mounted using PCB holes.
- First fixation with M3 nuts, then solder secondary pins.
- Installation of the transducer must be done unless otherwise specified on the datasheet, according to LEM Transducer Generic Mounting Rules. Please refer to LEM document N°ANE120504 available on our Web site: <https://www.lem.com/en/file/3137/download/>.