

HTx8-600 600V 8A TRIAC

FEATURES

- Repetitive Peak Off-State Voltage: 600V
- R.M.S On –State Current ($I_{T(RMS)} = 8A$)
- High Commutation dv/dt

$$V_{DRM} = 600 V$$

$$I_{T(RMS)} = 8.0 A$$

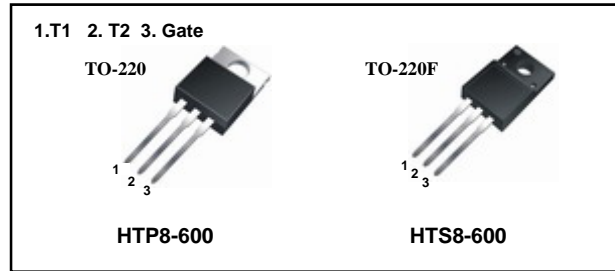
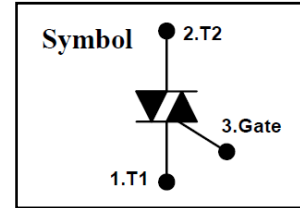

General Description

The TRIAC HTP8-600 is suitable for AC switching application, phase control application such as heater control, motor control, lighting control, and static switching relay.

Absolute Maximum Ratings $(T_a=25^{\circ}C)$

Symbol	Parameter	Value	Units
V_{DRM}	Repetitive Peak Off-State Voltage	600	V
$I_{T(RMS)}$	R.M.S On-State Current ($T_a = 105^{\circ}C$)	HTP8-600	8 A
	R.M.S On-State Current ($T_c = 89^{\circ}C$)	HTS8-600	
I_{TSM}	Surge On-State Current (One Cycle, 50/60Hz, Peak, Non Repetitive)	50Hz	80 A
		60Hz	88 A
V_{GM}	Peak Gate Voltage	10	V
I_{GM}	Peak Gate Current	2	A
P_{GM}	Peak Gate Power Dissipation	5	W
V_{ISO}	Isolation Breakdown Boltate, AC RMS 1Min (HTS8-600 only)	1500	V
T_{STG}	Storage Temperature Range	-40 to +125	$^{\circ}C$
T_J	Operating Temperature	-40 to +125	$^{\circ}C$

Electrical Characteristics (T_a=25°C)

Symbol	Parameter	Test Conditions		Min	Typ	Max	Units
I _{GT}	Gate Trigger Current	V _D =6V, R _L =10Ω	1+, 1-, 3-			30	mA
V _{GT}	Gate Trigger Voltage	V _D =6V, R _L =10Ω	1+, 1-, 3-			1.5	V
V _{GD}	Non Trigger Gate Voltage	T _J =125°C, V _D =1/2V _{DRM}		0.2			V
(dv/dt) _c	Critical Rate of Rise of Off-State Voltage at Communication	T _J =125°C, V _D =2/3V _{DRM} (di/dt) _c =4A/ms		5.0			V/μS
I _H	Holding Current				15		mA
I _{DRM}	Repetitive Peak Off-State Current	V _D =V _{DRM} , Single Phase Half Wave, T _J =125°C				2.0	mA
V _{TM}	Peak On-State Voltage	IT=12A, Inst, Measurement				1.4	V

Thermal Characteristics

Symbol	Parameter	Test Conditions	Case	Min	Typ	Max	Units
R _{θJC}	Thermal Resistance	Junction to Case	HTP8-600			2	°C/W
			HTS8-600			3.7	°C/W

Typical Characteristics

Fig 1. Gate Characteristics

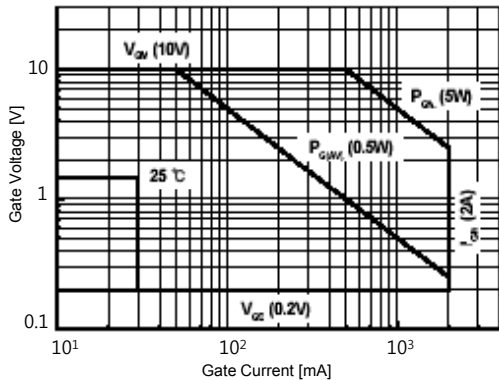

Fig 2. On-State Voltage

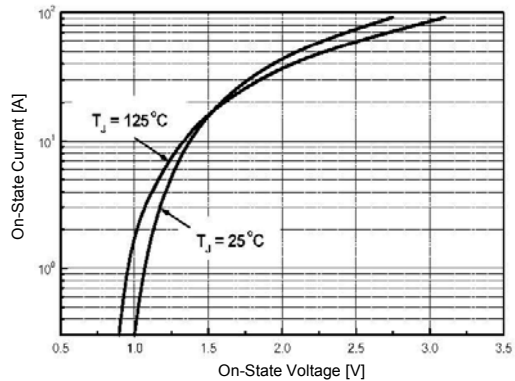

Fig 3. Gate Trigger Voltage vs. Junction Temperature

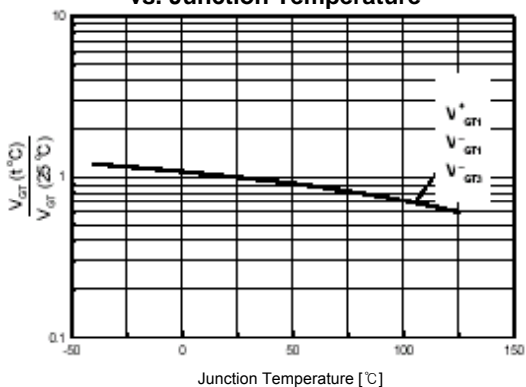

Fig 4. On-State Current vs. Maximum power Dissipation

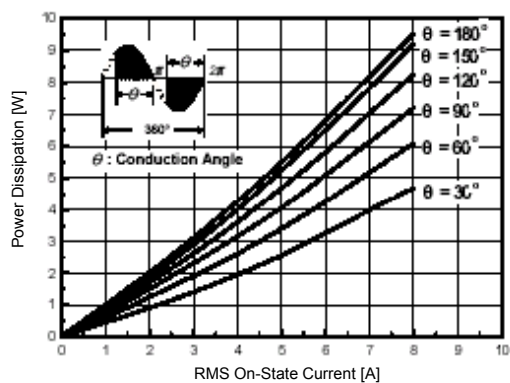

Fig 5. On-State Current vs. Allowable Case Temperature

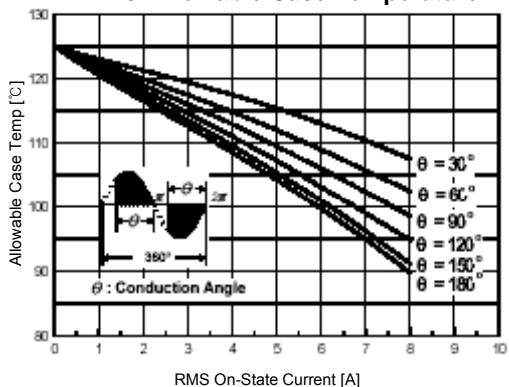
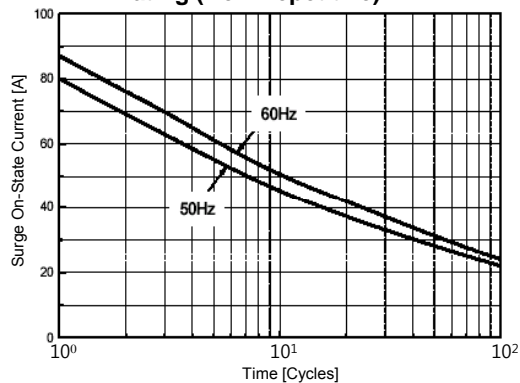

Fig 6. Surge On-State Current Rating (Non-Repetitive)



Typical Characteristics

Fig 7. Gate Trigger Current vs. Junction Temperature

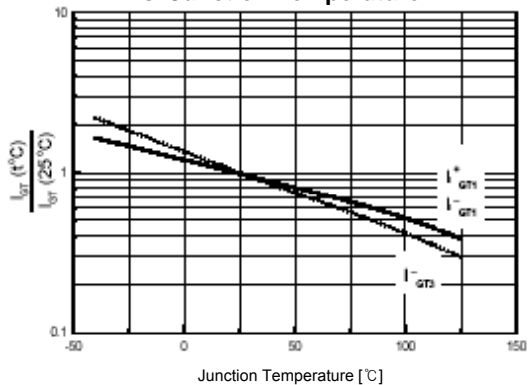

Fig 8. Transient Thermal Impedance

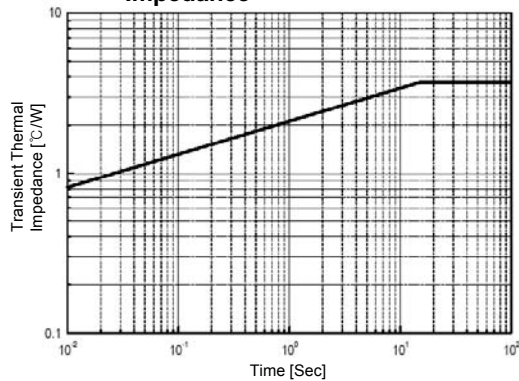
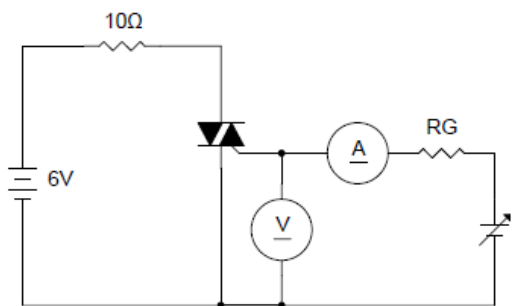
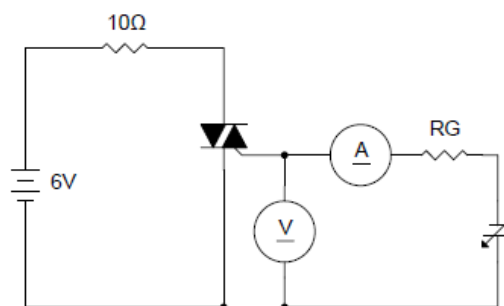

Fig 9. Gate Trigger Characteristics Test Circuit



Test Procedure I



Test Procedure II

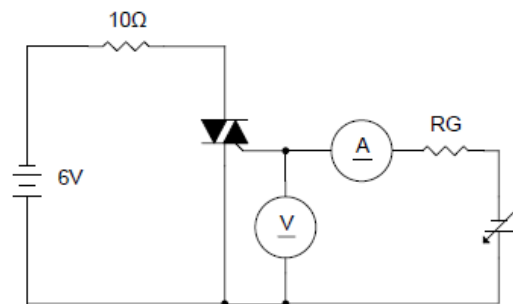

Test Procedure III

Package Dimension

HTP8-600
(TO-220)

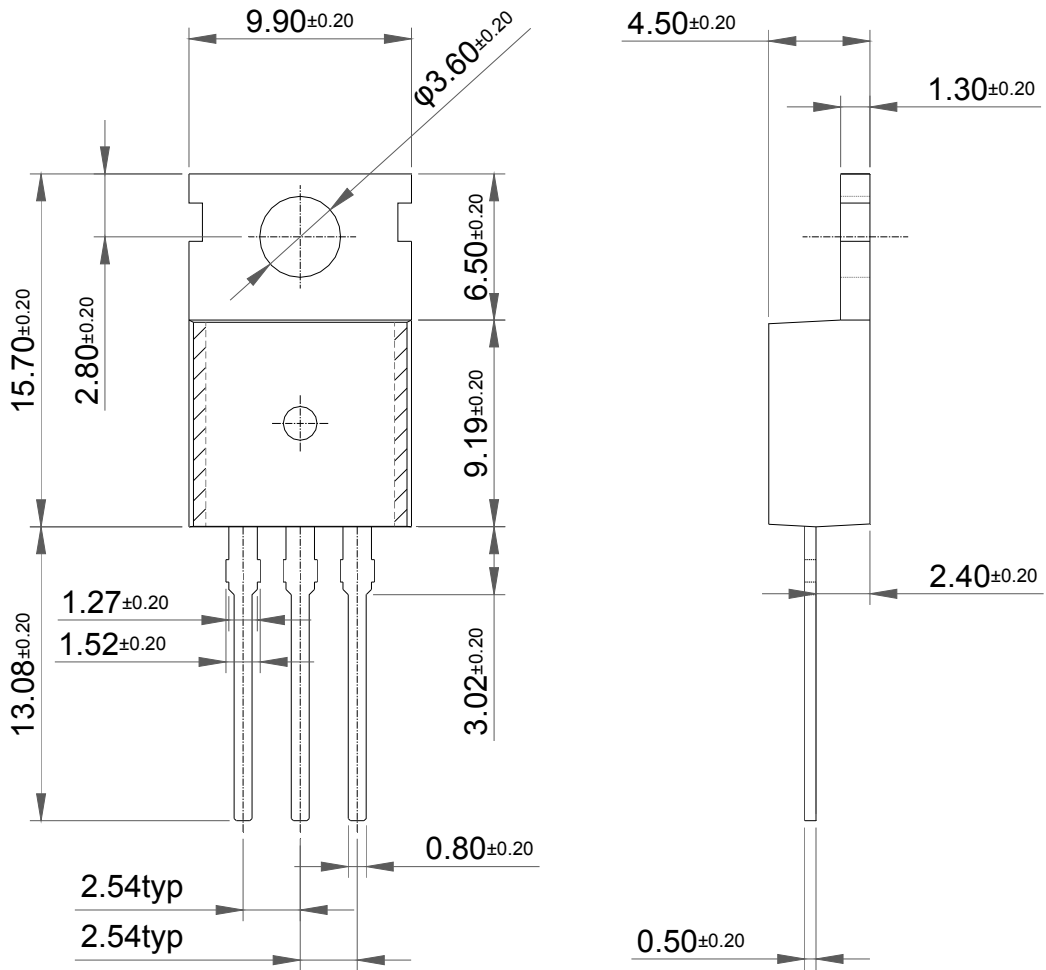

HTX8-600

Package Dimension

HTS8-600
(TO-220F)

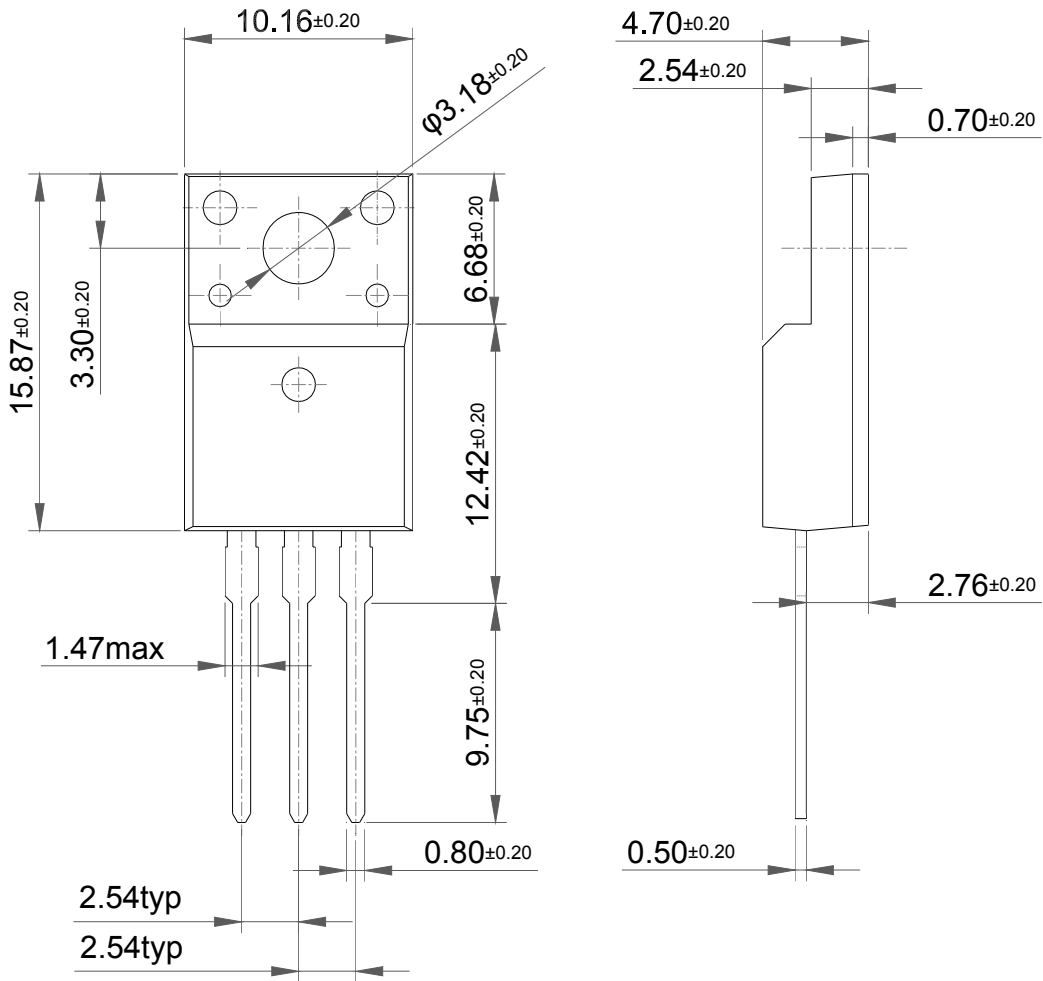

HTS8-600