



PROPRIETARY NOTE

THIS SPECIFICATION IS THE PROPERTY OF HYDIS AND SHALL NOT BE REPRODUCED OR COPIED WITHOUT THE WRITTEN PERMISSION OF HYDIS AND MUST BE RETURNED TO HYDIS UPON ITS REQUEST

TITLE : HV101WX1-1E1
Preliminary Product Specification
For. Customer _ Rev. A

HYDIS Technologies

SPEC. NUMBER	PRODUCT GROUP TFT LCD	REV. A	ISSUE DATE 2011. 05. 25	PAGE 1 OF 33
--------------	--------------------------	-----------	----------------------------	-----------------



HYDIS

PRODUCT GROUP

REV

ISSUE DATE

TFT LCD PRODUCT

A

2011. 05. 25

REVISION HISTORY

REV.	ECN NO.	DESCRIPTION OF CHANGES	DATE	PREPARED
0	-	▪ Initial Release	2011. 05. 03	H.S.LEE
A	-	▪ Corrected label model name (P27)	2011. 05. 25	H.S.LEE



PRODUCT GROUP

REV

ISSUE DATE

TFT LCD PRODUCT

A

2011. 05. 25

Contents

No	Item	Page
1.0	General Description	4
2.0	Absolute Maximum Ratings	6
3.0	Electrical Specifications	7
4.0	Optical Specifications	9
5.0	Interface Connections	14
6.0	Signal Timing Specifications	17
7.0	Signal Timing Waveforms	17
8.0	Input Signals, Basic Display Colors & Gray Scale of Colors	19
9.0	Power Sequence	20
10.0	Mechanical Characteristics	21
11.0	Mechanical Drawing	22
12.0	Reliability Test	25
13.0	Handling & Cautions	25
14.0	Labels	27
15.0	Packing Information	29
16.0	EDID	31

SPEC. NUMBER

SPEC TITLE

HV101WX1-1E1 Preliminary Product Specification for Customer

PAGE

3 OF 33

B2005-C001-D (3/3)

A4(210 X 297)

1.0 GENERAL DESCRIPTION

1.1 Introduction

HV101WX1-1E1 is a color active matrix TFT LCD module using amorphous silicon TFT's (Thin Film Transistors) as an active switching devices. This module has a 10.1 inch diagonally measured active area with WXGA resolutions (1280 horizontal by 800 vertical pixel array). Each pixel is divided into RED, GREEN, BLUE dots which are arranged in vertical Stripe and this module can display 16,777,216 colors. The TFT-LCD panel used for this module is a low reflection and higher color type.

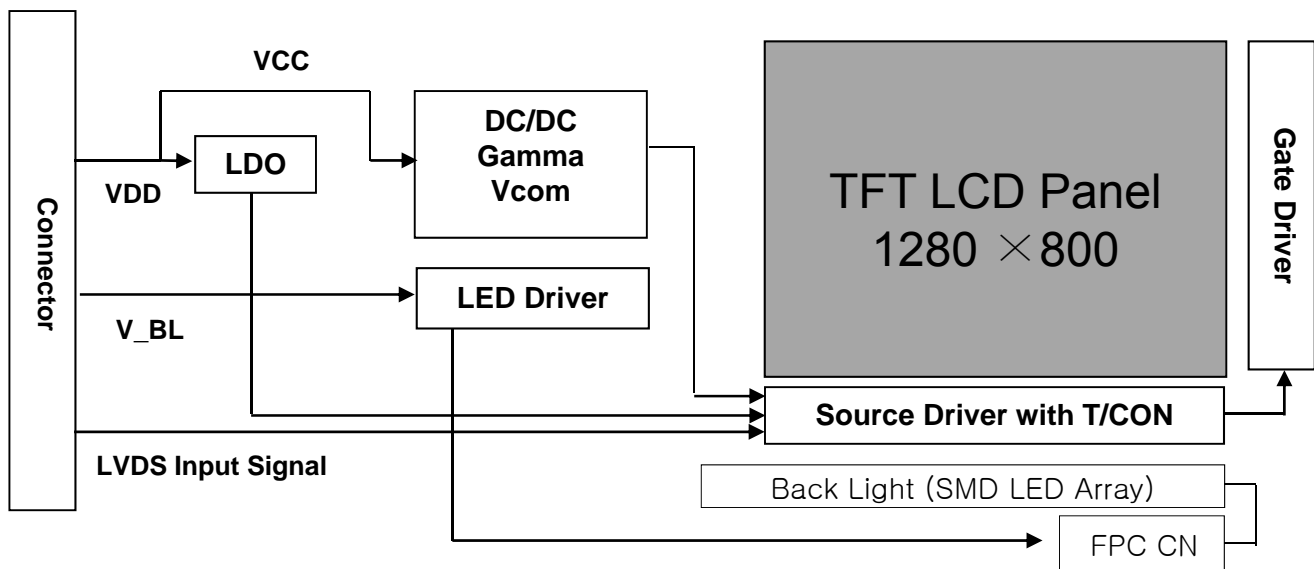

1.2 Features

- Thin and Light Weight
- 3.3 V Logic Power Supply
- 12V Back-light Power Supply
- 1 Channel LVDS Interface
- SMD LED (42EA) Array (Bottom Side/Horizontal Direction)
- 16,777,216 Colors (With dither & HFRC)
- Data Enable Signal Mode
- Front Mounting Frame
- Green Product (RoHS)



PRODUCT GROUP

REV

ISSUE DATE

TFT LCD PRODUCT

A

2011. 05. 25

1.3 General Specifications

Parameter	Specification	Unit	Remarks
Active area	216.96(H) × 135.60(V)	mm	
Number of pixels	1280(H) × 800(V)	pixels	
Pixel pitch	0.1695(H) × 0.1695(V)	mm	
Pixel arrangement	RGB Vertical Stripe		
Display colors	16,777,216	colors	
Display mode	Normally Black		
Outline dimension	229.46±0.5(H) × 149.2±0.5(V) × 2.8±0.3(D)	mm	Note 1
Weight	160(Typ.)	g	
Back-light	SMD LED (42EA) Array		
Surface treatment	HCLR		

Note 1 : At LED side (PCB Side: 4.7mm±0.3)

SPEC. NUMBER

SPEC TITLE

HV101WX1-1E1 Preliminary Product Specification for Customer

PAGE

5 OF 33

B2005-C001-D (3/3)

A4(210 X 297)

2.0 ABSOLUTE MAXIMUM RATINGS

The followings are maximum values which, if exceed, may cause faulty operation or damage to the unit.

Ta=25+/-2°C

Parameter	Symbol	Min.	Max.	Unit	Remarks
Logic Power Supply Voltage	V _{DD}	-0.3	4.0	V	
Logic Power Supply Voltage	V _{IN}	-0.3	V _{DD} +0.3	V	
Back-light Power Supply Voltage	HV _{DD}	-0.3	28	V	
Back-light LED Current	I _{LED}	-	27	mA	Note 1
Back-light LED Reverse Voltage	V _R	-	5	V	
Operating Temperature	T _{OP}	0	+50	°C	Note 1, Note 2
Storage Temperature	T _{SP}	-20	+60	°C	

Note 1. Ambient temperature vs allowable forward current are shown in the figure below.

Note 2. Temperature and relative humidity range are shown in the figure below.

95% RH Max. (40°C ≥ Ta)

Maximum wet - bulb temperature at 39°C or less. (> 40°C) No condensation.

Ambient Temperature vs. Maximum Forward Current

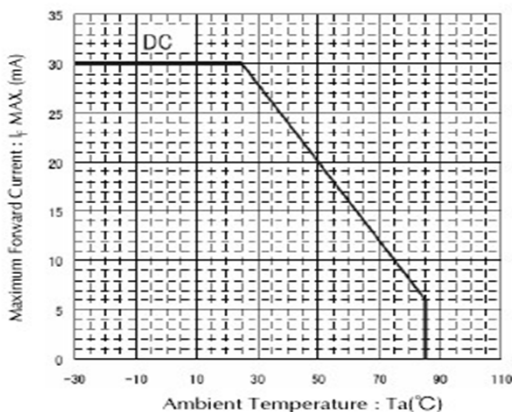

Relative Humidity (%RH)

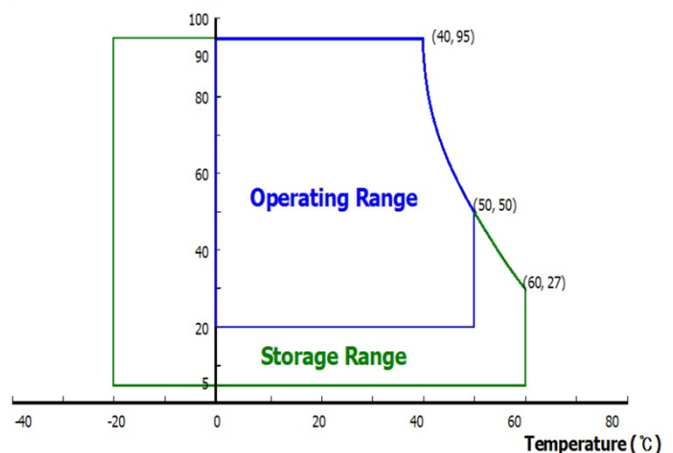



PRODUCT GROUP

REV

ISSUE DATE

TFT LCD PRODUCT

A

2011. 05. 25

3.0 ELECTRICAL SPECIFICATIONS

3.1 Electrical Specifications

Parameter		Min.	Typ.	Max.	Unit	Remarks
Logic Power Supply Voltage	V_{DD}	3.0	3.3	3.6	V	Note 1
Logic Power Supply Current	I_{DD}	-	272	TBD	mA	Note 1
Back-light Power Supply Voltage	HV_{DD}	7.0	12.0	21	V	Note 2
Back-light Power Supply Current	I_{HVDD}	-	TBD	-	mA	Note 2, 3
Back-light Power Consumption	P_{BL}	-	TBD	-	W	Note 2, 3
LED Driver's Efficiency	η	-	85	-	%	Note 2, 3
Back-light PWM Frequency	F_{PWM}	100	-	1000	Hz	
Back-light Duty ratio		1		100	%	
High Level PWM Signal Voltage	V_{PWMH}	2.1	3.3	5.0	V	
Low Level PWM Signal Voltage	V_{PWML}	-	0	0.6	V	
High Level Differential Input Signal Voltage	V_{IH}	-	-	+100	mV	
Low Level Differential Input Signal Voltage	V_{IL}	-100	-	-	mV	
Back-light LED Voltage / Back-light LED Total Voltage	V_{LED} / V_{BL}	-	3.2 / 22.4	-	V	Note 4
Back-light LED Current / Back-light LED Total Current	I_{LED} / I_{BL}	-	19.5 / 117	-	mA	Note 4
Life Time		12,000	-	-	Hrs	Note 6
Power Consumption	P_D	-	0.9		W	Note 1
	P_{LED}	-	2.62	-	W	Note 4
	P_{total}	-	3.52	-	W	Note 1, 4

SPEC. NUMBER

SPEC TITLE

HV101WX1-1E1 Preliminary Product Specification for Customer

PAGE

7 OF 33

B2005-C001-D (3/3)

A4(210 X 297)

- Notes :
1. The supply voltage is measured and specified at the interface connector of LCM.
The current draw and power consumption specified is for 3.3V at 25°C.
a) Typ : Window XP pattern, b) Max : White.
 2. The power supply voltage and current is measured and specified at the interface connector of LCM including LED Driver.
 3. Reference value, which is measured with LED Driver for 12V.
 4. Reference value, which is measured without LED Driver.
 5. Calculated value for reference ($V_{LED} \times I_{LED} \times \# \text{ of LEDs (42EA) }$).
 6. End of Life shall be determined by the time when any of the following is satisfied under continuous lighting at 25°C and $I_{LED} = 19.5\text{mA}$.
 - . Intensity drops to 50% of the Initial Value (Luminance Spec.)
 - . Based on LED

3.2 PWM Duty Ratio vs Brightness

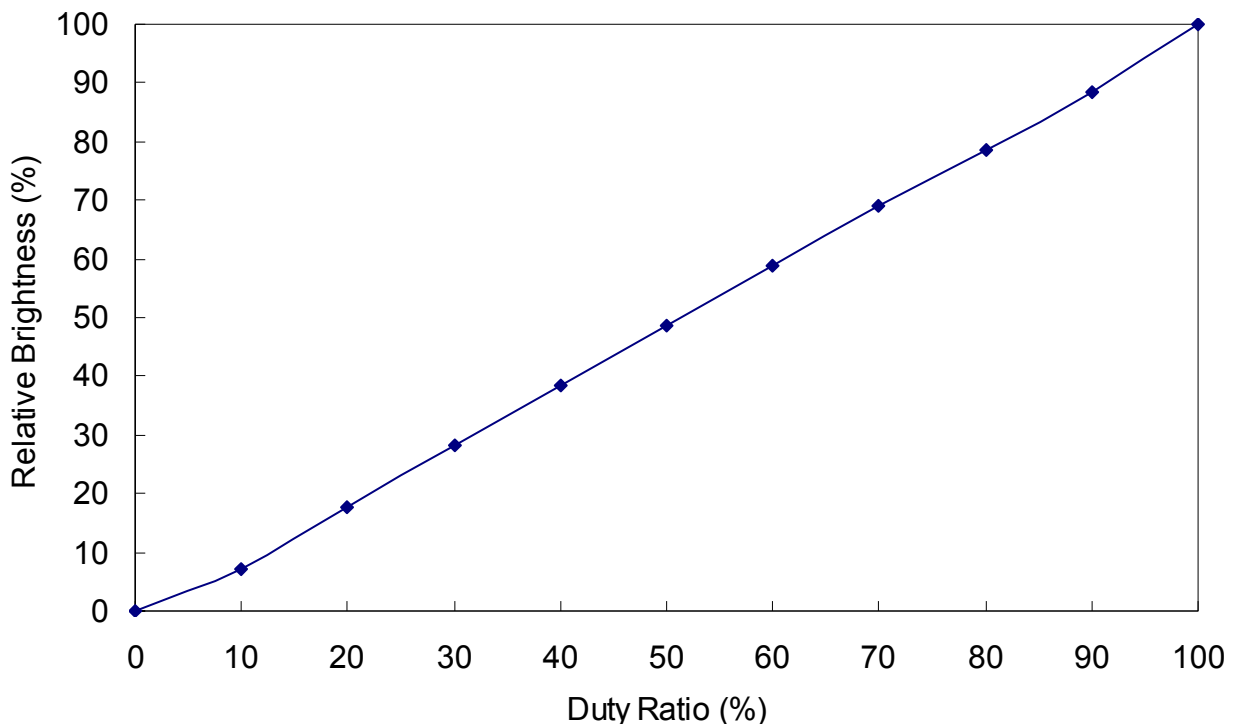



PRODUCT GROUP

REV

ISSUE DATE

TFT LCD PRODUCT

A

2011. 05. 25

4.0 OPTICAL SPECIFICATIONS

4.1 Overview

The test of optical specifications shall be measured in a dark room (ambient luminance ≤ 1 lux and temperature = $25 \pm 2^\circ\text{C}$) with the equipment of Luminance meter system (Goniometer system and TOPCON BM-5A) and test unit shall be located at an approximate distance 50cm from the LCD surface at a viewing angle of θ and Φ equal to 0° . We refer to $\theta_{\Phi=0}$ ($=\theta_3$) as the 3 o'clock direction (the "right"), $\theta_{\Phi=90}$ ($=\theta_{12}$) as the 12 o'clock direction ("upward"), $\theta_{\Phi=180}$ ($=\theta_9$) as the 9 o'clock direction ("left") and $\theta_{\Phi=270}$ ($=\theta_6$) as the 6 o'clock direction ("bottom"). While scanning θ and/or Φ , the center of the measuring spot on the Display surface shall stay fixed. The backlight should be operating for 30 minutes prior to measurement. V_{DD} shall be $3.3 \pm 0.3\text{V}$ at 25°C . Optimum viewing angle direction is 6 o'clock.

4.2 Optical Specifications

Parameter		Symbol	Condition	Min.	Typ.	Max.	Unit	Remarks
Viewing Angle Range	Horizontal	θ_3	CR > 10	80	85	-	Deg.	Note 1
		θ_9		80	85	-	Deg.	
	Vertical	θ_{12}		80	85	-	Deg.	
		θ_6		80	85	-	Deg.	
Luminance Contrast Ratio		CR	$\Theta = 0^\circ$	500	800	-	-	Note 2
Luminance of White	Center	Y_w		-	400	-	cd/m ²	
White Luminance Uniformity	5 Points	ΔY_5		80	-	-	%	Note 3
	13 Points	ΔY_{13}		60	-	-		
Color Chromaticity	White	W_x		0.283	0.313	0.343	Note 4	
		W_y		0.299	0.329	0.359		
	Red	R_x			TBD			
		R_y			TBD			
	Green	G_x			TBD			
		G_y			TBD			
	Blue	B_x		TBD				
		B_y		TBD				
Color Reproduction				50		%		
Response Time	Total ($T_r + T_d$)		Ta = 25°C $\Theta = 0^\circ$	-	32	-	ms	Note 5
Cross Talk	CT		$\Theta = 0^\circ$	-	-	2.0	%	Note 6

SPEC. NUMBER

SPEC TITLE

HV101WX1-1E1 Preliminary Product Specification for Customer

PAGE

9 OF 33



PRODUCT GROUP

REV

ISSUE DATE

TFT LCD PRODUCT

A

2011. 05. 25

Note : 1. Viewing angle is the angle at which the contrast ratio is greater than 10. The viewing are determined for the horizontal or 3, 9 o'clock direction and the vertical or 6, 12 o'clock direction with respect to the optical axis which is normal to the LCD surface (see FIGURE 1 shown in page 11).

2. Contrast measurements shall be made at viewing angle of $\Theta = 0^\circ$ and at the center of the LCD surface. Luminance shall be measured with all pixels in the view field set first to white, then to the dark (black) state. (See FIGURE 1 shown in page 11)
Luminance Contrast Ratio (CR) is defined mathematically.

$$CR = \frac{\text{Luminance when displaying a white raster}}{\text{Luminance when displaying a black raster}}$$

3. The White luminance uniformity on LCD surface is then expressed.
(See FIGURE 2~3 shown in page 12)

$$\text{Uniformity } \Delta Y = \frac{\text{Minimum Luminance of 5(or 13) points}}{\text{Maximum Luminance of 5(or 13) points}} \times 100 (\%)$$

4. The color chromaticity coordinates specified in Table 4 shall be calculated from the spectral data measured with all pixels first in red, green, blue and white. Measurements shall be made at the center of the panel.

5. The electro-optical response time measurements shall be made as FIGURE 4 shown in page 13 by switching the "data" input signal OFF and ON. The times needed for the luminance to change from 10% to 90% is T_r , and 90% to 10% is T_d . (See FIGURE 4 shown in page 13)

6. Cross-Talk of one area of the LCD surface by another shall be measured by comparing the luminance (YA) of a 25mm diameter area, with all display pixels set to a gray level, to the luminance (YB) of that same area when any adjacent area is driven dark. (See FIGURE 5 shown in page 13)

SPEC. NUMBER

SPEC TITLE

HV101WX1-1E1 Preliminary Product Specification for Customer

PAGE

10 OF 33

B2005-C001-D (3/3)

A4(210 X 297)

4.3 Optical Measurements

Figure 1. Measurement Set Up

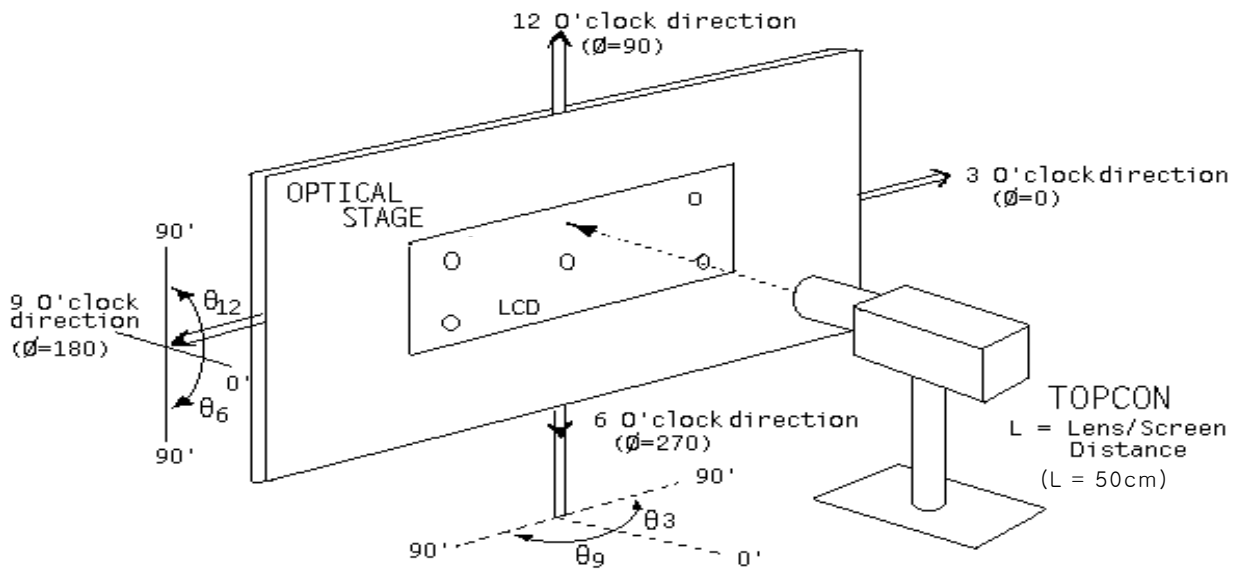

SPEC. NUMBER

SPEC TITLE

HV101WX1-1E1 Preliminary Product Specification for Customer

PAGE

11 OF 33

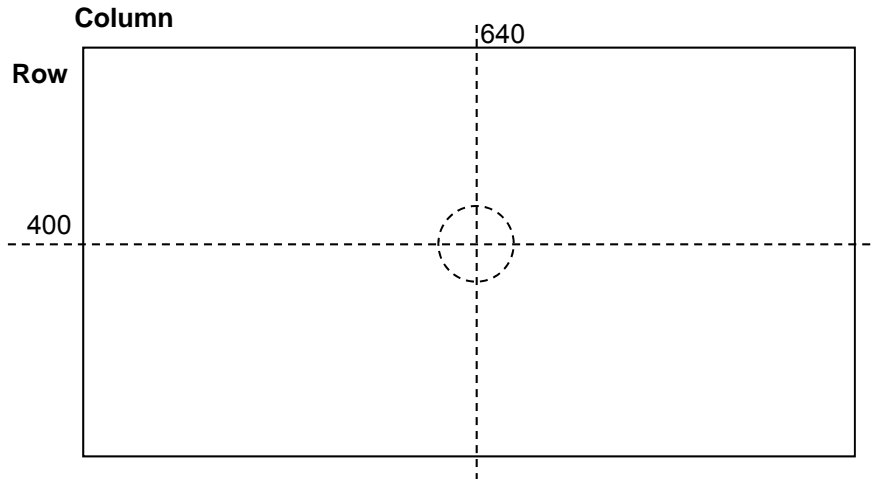
Figure 2. White Luminance and Uniformity Measurement Locations (Center 1point)

Note.

Luminance of white is defined as luminance values of center 1 point across the LCD surface. Luminance shall be measured with all pixels in the view field set first to white. This measurement shall be taken at the locations shown in Figure 2.

Figure 3. Uniformity Measurement Locations (13 points)

Figure 4. Response Time Testing

Figure 5. Cross Modulation Test Description

$$\text{Cross-Talk (\%)} = \left| \frac{Y_B - Y_A}{Y_B} \right| \times 100$$

Where:

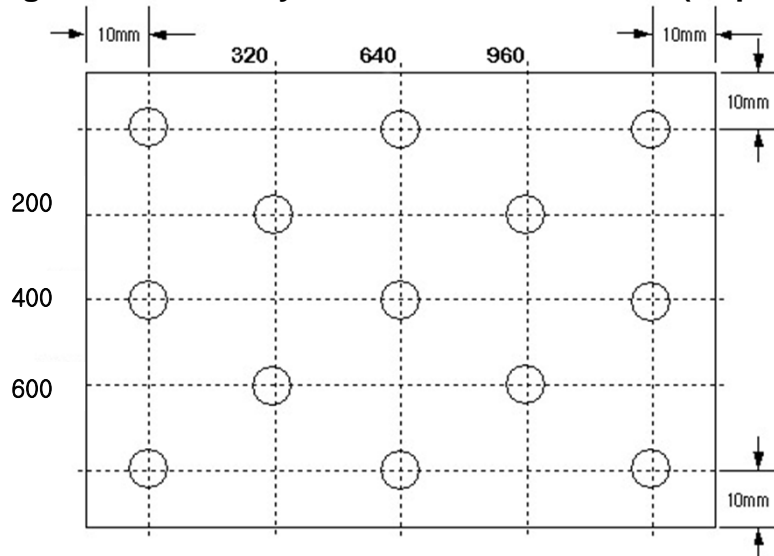
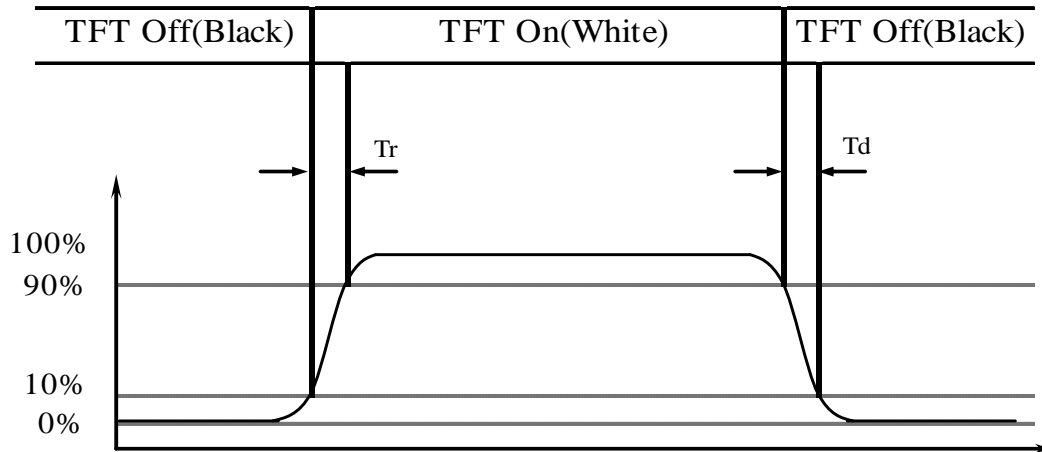
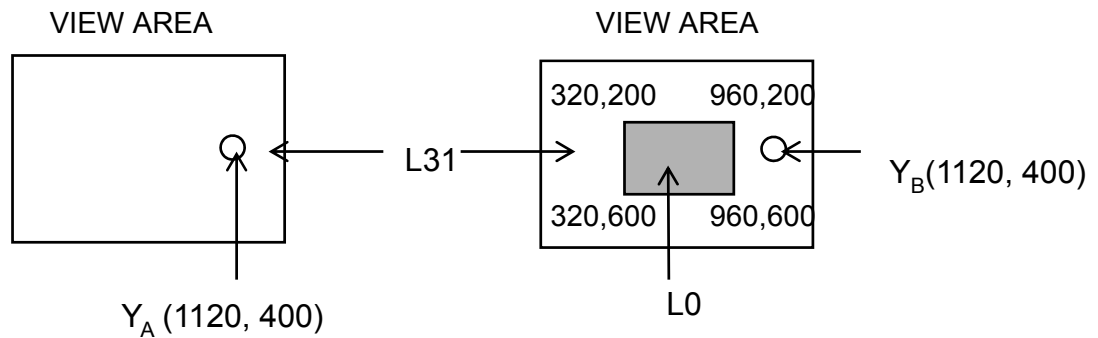
 Y_A = Initial luminance of measured area (cd/m²)

 Y_B = Subsequent luminance of measured area (cd/m²)

The location measured will be exactly the same in both patterns

5.0 INTERFACE CONNECTIONS

5.1 Electrical Interface Connection

CN1 Interface Connector (HD1S040HA1, Manufactured by JAE)

Pin No.	Symbol	Function	Pin No.	Symbol	Function
1	NC	Non Connection (BIST)	21	Rin3+	+LVDS input(R6,7/G6,7/B6,7)
2	LVDD	Logic Power Supply:+3.3V	22	GND	Ground
3	LVDD	Logic Power Supply:+3.3V	23	NC	Non Connection
4	VDD_EDID	EDID Power Supply:+3.3V	24	NC	Non Connection
5	NC	Non Connection	25	GND	Ground
6	CLK_EDID	EDID Clock	26	NC	Non Connection
7	DATA_EDID	EDID Data	27	NC	Non Connection
8	Rin0-	-LVDS input(R0-R5, G0)	28	GND	Ground
9	Rin0+	+LVDS input(R0-R5, G0)	29	NC	Non Connection
10	GND	Ground	30	NC	Non Connection
11	Rin1-	-LVDS input(G1-G5,B0-B1)	31	GND	Ground
12	Rin1+	+LVDS input(G1-G5,B0-B1)	32	GND	Ground
13	GND	Ground	33	GND	Ground
14	Rin2-	-LVDS input(B2-B5,HS,VS,DE)	34	NC	Non Connection
15	Rin2+	+LVDS input(B2-B5,HS,VS,DE)	35	BLIM	PWM control
16	GND	Ground	36	BL_EN	BL on/off
17	ClKIN-	-LVDS clock	37	NC	Non Connection
18	ClKIN+	+LVDS clock	38	VBL+	LED Power supply
19	GND	Ground	39	VBL+	LED Power supply
20	Rin3-	-LVDS input(R6,7/G6,7/B6,7)	40	VBL+	LED Power supply

※ Note1) In order to operate BIST mode, PIN1 should be applied 3.3V (BIST high signal) after 1 frame normal operation (LVDS Power High).
(BIST is used at LCM maker.)



PRODUCT GROUP

REV

ISSUE DATE

TFT LCD PRODUCT

A

2011. 05. 25

5.2 LVDS Interface

LVDS Transmitter : THC63LVDM83A

Input Signal	Transmitter		Interface		HD1S040HA1	Remark					
	Pin No.	Pin No.	System (Tx)	TFT-LCD (Rx)	Pin No.						
R0	51	48	OUT0-	IN0-	8						
R1	52										
R2	54										
R3	55										
R4	56										
R5	3										
G0	4	47	OUT0+	IN0+	9						
G1	6										
G2	7										
G3	11										
G4	12										
G5	14										
B0	15	46	OUT1-	IN1-	11						
B1	19										
B2	20										
B3	22										
B4	23										
B5	24										
HSYNC	27	45	OUT1+	IN1+	12						
VSYNC	28										
DE	30	42	OUT2-	IN2-	14						
MCLK	31						40	CLKOUT-	CLKIN-	17	
							39	CLKOUT+	CLKIN+	18	
R6	50						38	OUT2+	IN2+	15	
R7	2										
G6	8										
G7	10										
B6	16										
B7	18										
RSVD	25	37	OUT3-	IN3-	20						
		37	OUT3+	IN3+	21						

SPEC. NUMBER

SPEC TITLE

HV101WX1-1E1 Preliminary Product Specification for Customer

PAGE

15 OF 33



PRODUCT GROUP

REV

ISSUE DATE

TFT LCD PRODUCT

A

2011. 05. 25

5.3 Back-light Interface

CN2 LED FPC Connector (20397-008E, Manufactured by I-PEX)

Pin No.	Symbol	Function	Remark
1	Anode	LED Anode Power Supply	3.2V X 7EA = 22.4V
2	NC	Non connection	
3	Cathode1	LED Cathode Power Supply	LED Cathode Power Supply
4	Cathode2	LED Cathode Power Supply	
5	Cathode3	LED Cathode Power Supply	
6	Cathode4	LED Cathode Power Supply	
7	Cathode5	LED Cathode Power Supply	
8	Cathode6	LED Cathode Power Supply	

5.4 Data Input Format

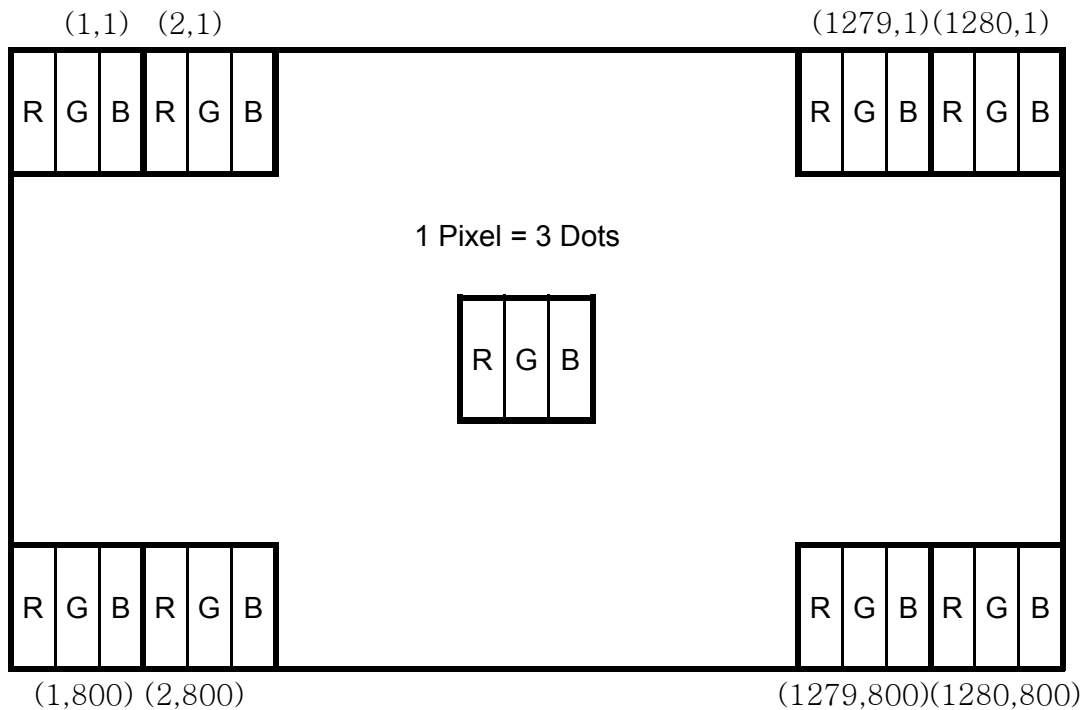

SPEC. NUMBER

SPEC TITLE

HV101WX1-1E1 Preliminary Product Specification for Customer

PAGE

16 OF 33

6.0. SIGNAL TIMING SPECIFICATIONS

6.1 The 10.1" WXGA LCM is operated by the only DE (Data enable) mode (LVDS Transmitter Input)

Item	Symbol	Min.	Typ.	Max.	Unit
Frame Period	T1	-	823	-	Lines
Vertical Display Period	T2	-	800	-	Lines
One line Scanning Period	T3	-	1440	-	Clocks
Horizontal Display Period	T4	-	1280	-	Clocks
Clock Frequency	1/T5	-	71.1	-	MHz

7.0 SIGNAL TIMING WAVEFORMS

7.1 Timing Waveforms of Interface Signal

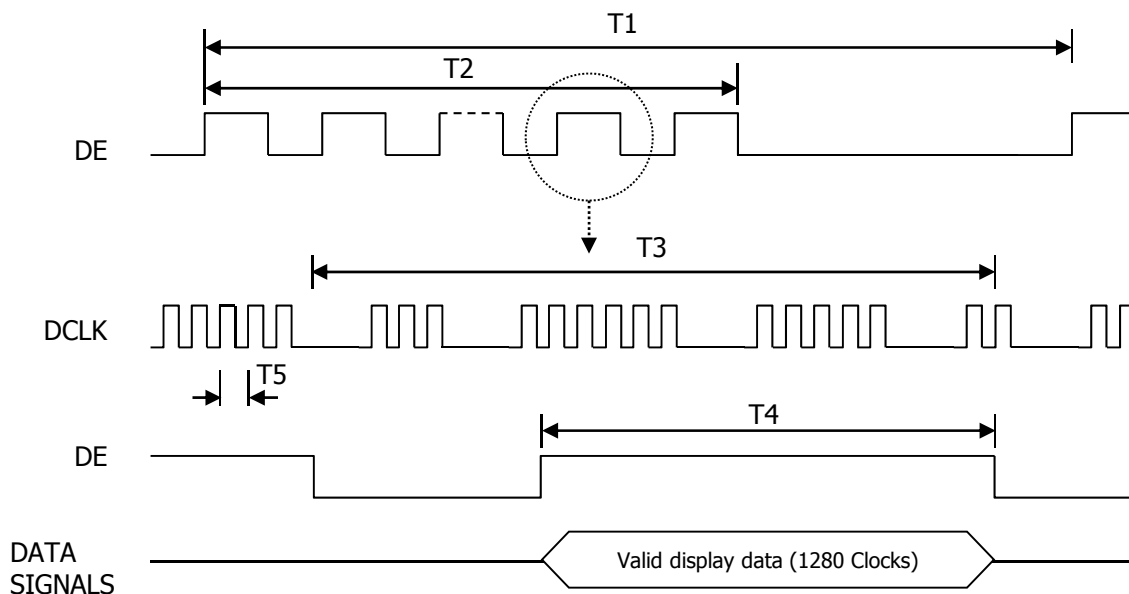

7.2 LVDS Rx Interface Timing Parameter

The specification of the LVDS Rx interface timing parameter

Item	Symbol	Min.	Typ.	Max.	Unit	Remarks
CLKIN Period	tRCIP	-	14.06	-	nsec	
Input Data 0	tRIP0	-0.4	0.0	+0.4	nsec	
Input Data 1	tRIP1	tRCIP/7-0.4	tRCIP/7	tRCIP/7+0.4	nsec	
Input Data 2	tRIP2	2 × tRCIP/7-0.4	2 × tRCIP/7	2 × tRCIP/7+0.4	nsec	
Input Data 3	tRIP3	3 × tRCIP/7-0.4	3 × tRCIP/7	3 × tRCIP/7+0.4	nsec	
Input Data 4	tRIP4	4 × tRCIP/7-0.4	4 × tRCIP/7	4 × tRCIP/7+0.4	nsec	
Input Data 5	tRIP5	5 × tRCIP/7-0.4	5 × tRCIP/7	5 × tRCIP/7+0.4	nsec	
Input Data 6	tRIP6	6 × tRCIP/7-0.4	6 × tRCIP/7	6 × tRCIP/7+0.4	nsec	

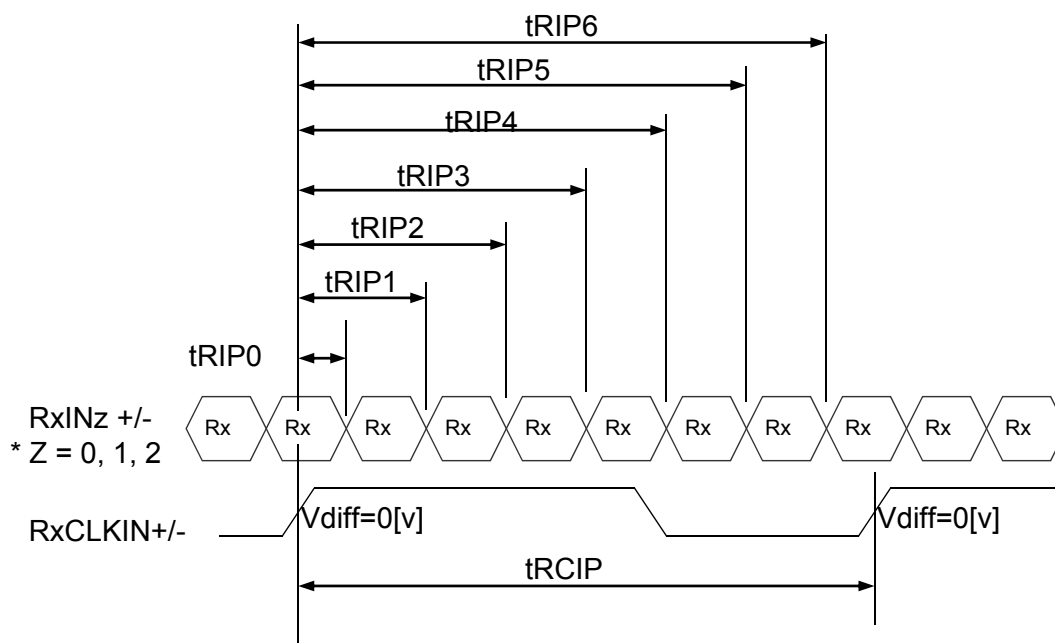



PRODUCT GROUP

REV

ISSUE DATE

TFT LCD PRODUCT

A

2011. 05. 25

8.0 INPUT SIGNALS, BASIC DISPLAY COLORS & GRAY SCALE OF COLORS

Each color is displayed in sixty-four gray scales from a 8 bit data signal input. A total of 16,777,216 colors are derived from the resultant 24 bit data.

Colors & Gray Scale		Data signal																							
		Red data							Green data							Blue data									
		R0	R1	R2	R3	R4	R5	R6	R7	G0	G1	G2	G3	G4	G5	G6	G7	B0	B1	B2	B3	B4	B5	B6	B7
Basic Colors	Black	0	0	0	0	0	0	0	0	0	0	0	0	0	0	0	0	0	0	0	0	0	0	0	0
	Blue	0	0	0	0	0	0	0	0	0	0	0	0	0	0	0	0	1	1	1	1	1	1	1	1
	Green	0	0	0	0	0	0	0	1	1	1	1	1	1	1	1	0	0	0	0	0	0	0	0	0
	Light Blue	0	0	0	0	0	0	0	1	1	1	1	1	1	1	1	1	1	1	1	1	1	1	1	1
	Red	1	1	1	1	1	1	1	0	0	0	0	0	0	0	0	0	0	0	0	0	0	0	0	0
	Purple	1	1	1	1	1	1	1	0	0	0	0	0	0	0	0	1	1	1	1	1	1	1	1	1
	Yellow	1	1	1	1	1	1	1	1	1	1	1	1	1	1	1	0	0	0	0	0	0	0	0	0
	White	1	1	1	1	1	1	1	1	1	1	1	1	1	1	1	1	1	1	1	1	1	1	1	1
Gray Scale of Red	Black	0	0	0	0	0	0	0	0	0	0	0	0	0	0	0	0	0	0	0	0	0	0	0	
	△	1	0	0	0	0	0	0	0	0	0	0	0	0	0	0	0	0	0	0	0	0	0	0	
	Darker	0	1	0	0	0	0	0	0	0	0	0	0	0	0	0	0	0	0	0	0	0	0	0	
	△	↓							↓							↓									
	▽	↓							↓							↓									
	Brighter	1	0	1	1	1	1	1	0	0	0	0	0	0	0	0	0	0	0	0	0	0	0	0	0
	▽	↓							↓							↓									
	Red	1	1	1	1	1	1	1	0	0	0	0	0	0	0	0	0	0	0	0	0	0	0	0	0
Gray Scale of Green	Black	0	0	0	0	0	0	0	0	0	0	0	0	0	0	0	0	0	0	0	0	0	0	0	
	△	0	0	0	0	0	0	0	1	0	0	0	0	0	0	0	0	0	0	0	0	0	0	0	
	Darker	0	0	0	0	0	0	0	0	1	0	0	0	0	0	0	0	0	0	0	0	0	0	0	
	△	↓							↓							↓									
	▽	↓							↓							↓									
	Brighter	0	0	0	0	0	0	0	1	0	1	1	1	1	1	1	0	0	0	0	0	0	0	0	0
	▽	↓							↓							↓									
	Green	0	0	0	0	0	0	0	1	1	1	1	1	1	1	1	0	0	0	0	0	0	0	0	0
Gray Scale of Blue	Black	0	0	0	0	0	0	0	0	0	0	0	0	0	0	0	0	0	0	0	0	0	0	0	
	△	0	0	0	0	0	0	0	0	0	0	0	0	0	0	0	1	0	0	0	0	0	0	0	
	Darker	0	0	0	0	0	0	0	0	0	0	0	0	0	0	0	0	1	0	0	0	0	0	0	
	△	↓							↓							↓									
	▽	↓							↓							↓									
	Brighter	0	0	0	0	0	0	0	0	0	0	0	0	0	0	0	1	0	1	1	1	1	1	1	
	▽	↓							↓							↓									
	Blue	0	0	0	0	0	0	0	0	0	0	0	0	0	0	0	1	1	1	1	1	1	1	1	
Gray Scale of White & Black	Black	0	0	0	0	0	0	0	0	0	0	0	0	0	0	0	0	0	0	0	0	0	0	0	
	△	1	0	0	0	0	0	0	1	0	0	0	0	0	0	0	1	0	0	0	0	0	0	0	
	Darker	0	1	0	0	0	0	0	0	1	0	0	0	0	0	0	0	1	0	0	0	0	0	0	
	△	↓							↓							↓									
	▽	↓							↓							↓									
	Brighter	1	0	1	1	1	1	1	1	0	1	1	1	1	1	1	1	0	1	1	1	1	1	1	
	▽	↓							↓							↓									
	White	1	1	1	1	1	1	1	1	1	1	1	1	1	1	1	1	1	1	1	1	1	1	1	

SPEC. NUMBER
B2005-C001-D (3/3)

SPEC TITLE
HV101WX1-1E1 Preliminary Product Specification for Customer

PAGE
19 OF 33
A4(210 X 297)

9.0 SEQUENCE

To prevent a latch-up or DC operation of the LCD module, the power on/off sequence shall be as shown in below

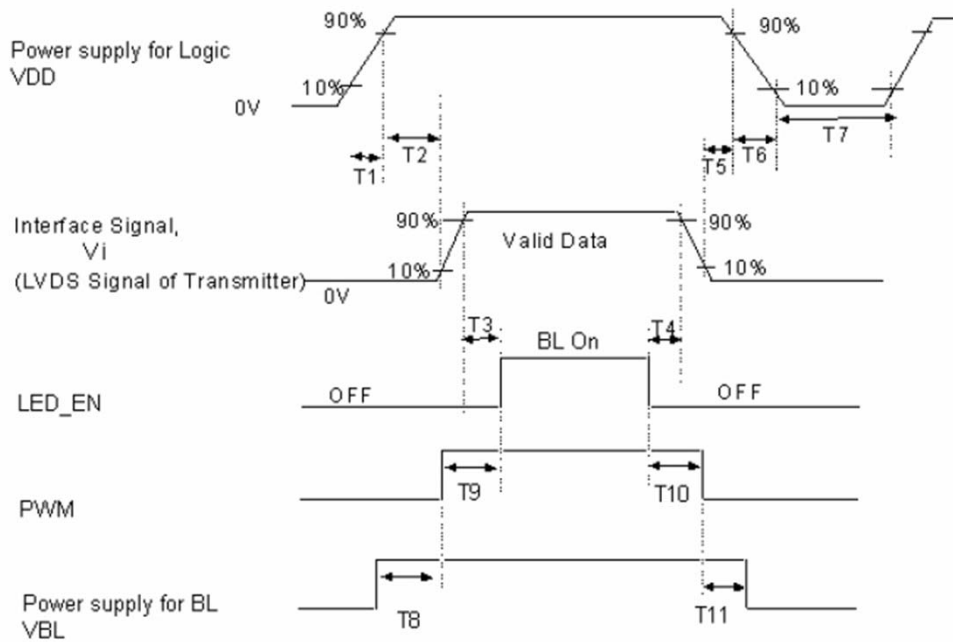

ITEMS	Unit	Min.	Typ.	Max.
T1	ms	0.5	-	10
T2	ms	0	-	50
T3	ms	200	-	-
T4	ms	0	-	-
T5	ms	0	-	-
T6	ms	0	-	10
T7	ms	150	-	-
T8 (Only Internal controller)	ms	0	-	-
T9 (Only Internal controller)	ms	0	-	-
T10 (Only Internal controller)	ms	0	-	-
T11 (Only Internal controller)	ms	0	-	-

- Notes :
1. When the power supply VDD is 0V, Keep the level of input signals on the low or keep high impedance.
 2. Do not keep the interface signal high impedance when power is on.
 3. Back Light must be turn on after power for logic and interface signal are valid.
 4. VDD and VBL circuit should be independent.



PRODUCT GROUP

REV

ISSUE DATE

TFT LCD PRODUCT

A

2011. 05. 25

10.0 MECHANICAL CHARACTERISTICS

10.1 Dimensional Requirements

Figure 6 & 7 (located in 11.0) shows mechanical outlines for the model

Parameter	Specification	Unit
Active Area	216.96(H) X 135.60(V)	mm
Number of pixels	1280(H) X 800(V) (1 pixel = R + G + B dots)	
Pixel pitch	0.1695(H) X 0.1695(V)	
Pixel arrangement	RGB Vertical stripe	
Display colors	16,777,216	
Display mode	Normally Black	
Outline dimension	$229.46 \pm 0.5(H) \times 149.2(V) \pm 0.5 \times 2.8(D) \pm 0.3$ (@LED side)	mm
Weight	160(Typ.)	g
Back-light	SMD LED (42EA) Array	

10.2 Polarizer

The surface of the LCD has an HCLR polarizer.

10.3 Light Leakage

There shall not be visible light from the back-lighting system around the edges of the screen as seen from a distance 50cm from the screen with an overhead light level of 150lux. The manufacture shall furnish limit samples of the panel showing the light leakage acceptable.

SPEC. NUMBER

SPEC TITLE

HV101WX1-1E1 Preliminary Product Specification for Customer

PAGE

21 OF 33

B2005-C001-D (3/3)

A4(210 X 297)

11.0 Mechanical Drawing

Figure 6. TFT-LCD Module Outline Dimension (Front View)

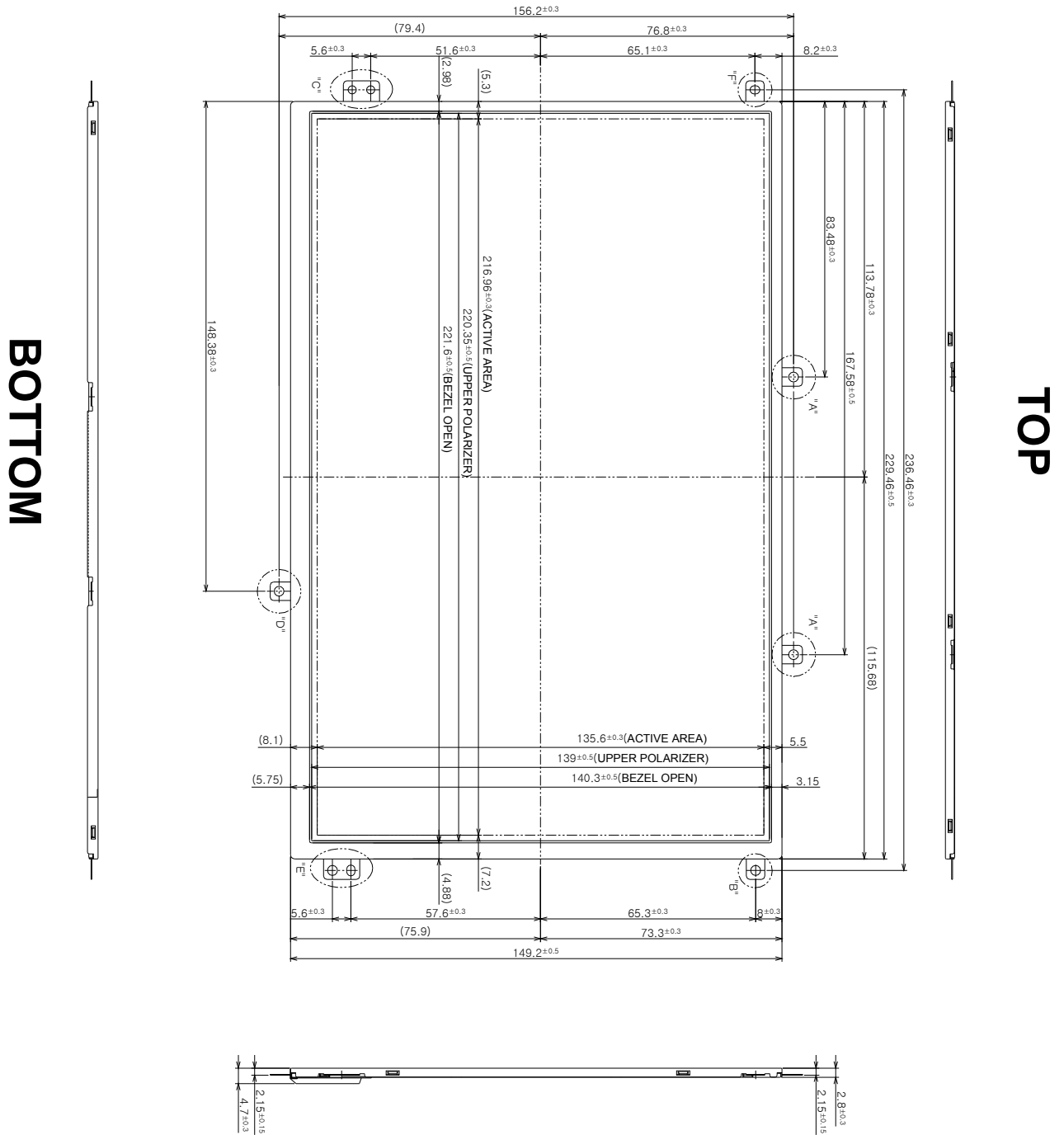

SPEC. NUMBER

SPEC TITLE
HV101WX1-1E1 Preliminary Product Specification for Customer

PAGE
22 OF 33

Figure 7. TFT-LCD Module Outline Dimensions (Rear view)

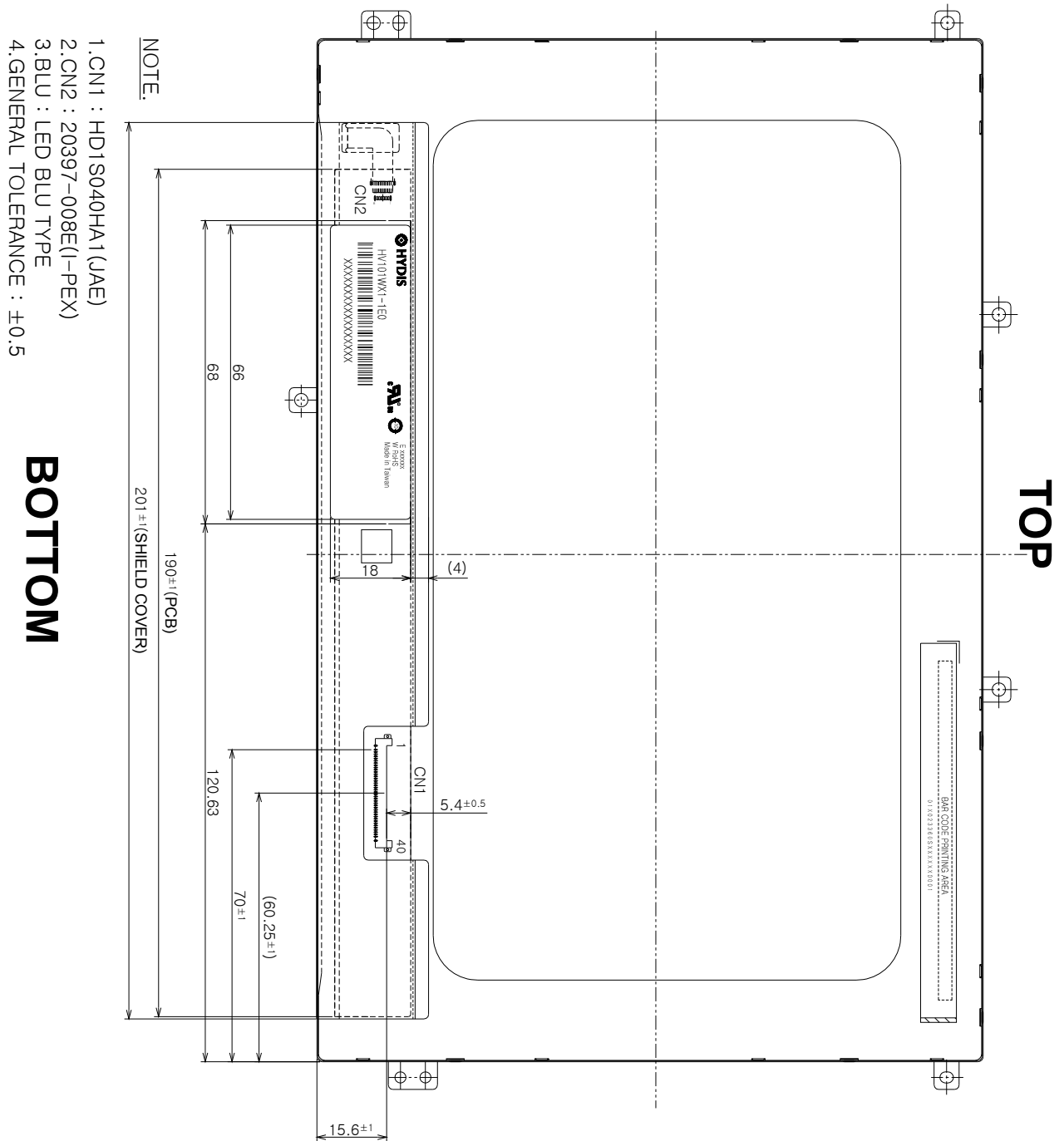
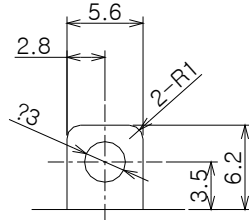
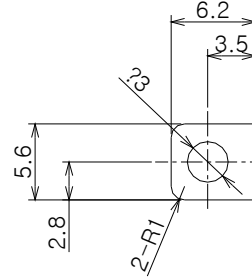
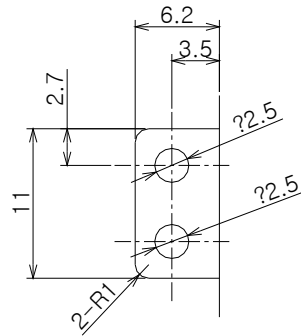

Figure 8. Detail drawings of TFT-LCD Module

DETAIL "A" (S : 2 / 1)



DETAIL "B" (S : 2 / 1)



DETAIL "C" (S : 2 / 1)

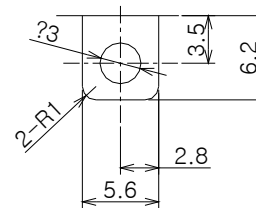

DETAIL "D" (S : 2 / 1)

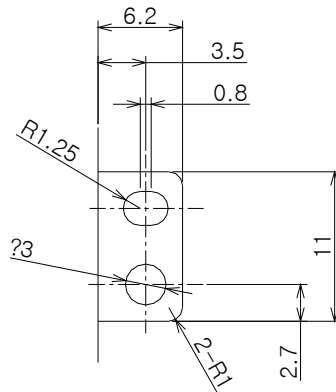

DETAIL "E" (S : 2 / 1)

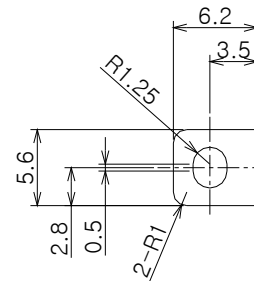

DETAIL "F" (S : 2 / 1)

12.0 RELIABILITY TEST

The Reliability test items and its conditions are shown in below.

No	Test Item	Conditions
1	High temperature storage test	Ta = 60 °C, 240 hrs
2	Low temperature storage test	Ta = -20 °C, 240 hrs
3	High temperature operation test	Ta = 50 °C, 240 hrs
4	High temperature & high humidity operation test	Ta = 50 °C, 80%RH, 240hrs
5	Low temperature operation test	Ta = 0 °C, 240 hrs
6	Thermal shock	Ta = -20 °C ↔ 60 °C (30 min), 100 cycle
7	Vibration test (non-operating)	Frequency : 10~500Hz Gravity/AMP : 1.5G Period : X,Y,Z 30min
8	Shock test (non-operating)	Gravity : 220G Pulse width : 2ms, half sine wave ±X, ±Y, ±Z Once for each direction
9	Electro-static discharge test (non-operating)	Air : 150pF, 330ohm, 15KV Contact : 150pF, 330ohm, 8KV

13.0 HANDLING & CAUTIONS

13.1 Cautions when taking out the module

- Pick the pouch only, when taking out module from a shipping package.

13.2 Cautions for handling the module

- As the electrostatic discharges may break the LCD module, handle the LCD module with care. Peel a protection sheet off from the LCD panel surface as slowly as possible.
- As the LCD panel and back - light element are made from fragile glass (epoxy) material, impulse and pressure to the LCD module should be avoided.
- As the surface of the polarizer is very soft and easily scratched, use a soft dry cloth without chemicals for cleaning.
- Do not pull the interface connector in or out while the LCD module is operating.
- Put the module display side down on a flat horizontal plane.
- Handle connectors and cables with care.



PRODUCT GROUP

REV

ISSUE DATE

TFT LCD PRODUCT

A

2011. 05. 25

13.3 Cautions for the operation

- When the module is operating, do not lose MCLK, DE signals. If any one of these signals were lost, the LCD panel would be damaged.
- Obey the supply voltage sequence. If wrong sequence is applied, the module would be damaged.

13.4 Cautions for the atmosphere

- Dew drop atmosphere should be avoided.
- Do not store and/or operate the LCD module in a high temperature and/or humidity atmosphere. Storage in an electro-conductive polymer packing pouch and under relatively low temperature atmosphere is recommended.

13.5 Cautions for the module characteristics

- Do not apply fixed pattern data signal to the LCD module at product aging.
- Applying fixed pattern for a long time may cause image sticking.

13.6 Cautions for the digitizer assembly

- When assembling FPC connector, do not flip connector past 90° due to possible damage to connector.
- When positioning digitizer underneath driver IC, do not lift driver IC past 90° due to possible damage to drive IC pattern.
- Please be warned that during assembly of digitizer, the opening or closing of FPC will result in possible electrostatic discharge damage to the LED

13.7 Other cautions

- Do not re-adjust variable resistor or switch etc.
- When returning the module for repair or etc., Please pack the module not to be broken. We recommend to use the original shipping packages.

SPEC. NUMBER

SPEC TITLE

HV101WX1-1E1 Preliminary Product Specification for Customer

PAGE

26 OF 33

B2005-C001-D (3/3)

A4(210 X 297)



PRODUCT GROUP

REV

ISSUE DATE

TFT LCD PRODUCT

A

2011. 05. 25

14.0 LABELS

14.1 Product Label



HV101WX1-1E1



E xxxxxx
W RoHS
Made in Taiwan



XXXXXXXXXXXXXXXXXXXX



Barcode

A	B	C	D	E	F	G	H	I
----------	----------	----------	----------	----------	----------	----------	----------	----------

Type designation

A: Year (0~9)

B ~ C : Week (01~52)

D~H : Serial No (0000~9999)

I : Factory code

SPEC. NUMBER

SPEC TITLE

HV101WX1-1E1 Preliminary Product Specification for Customer

PAGE

27 OF 33



PRODUCT GROUP

REV

ISSUE DATE

TFT LCD PRODUCT

A

2011. 05. 25

14.2 Packing Label

T.B.D

SPEC. NUMBER

SPEC TITLE

HV101WX1-1E1 Preliminary Product Specification for Customer

PAGE

28 OF 33

B2005-C001-D (3/3)

A4(210 X 297)



PRODUCT GROUP

REV

ISSUE DATE

TFT LCD PRODUCT

A

2011. 05. 25

15.0 PACKING INFORMATION

15.1 Box Packing

T.B.D

SPEC. NUMBER

SPEC TITLE

HV101WX1-1E1 Preliminary Product Specification for Customer

PAGE

29 OF 33

B2005-C001-D (3/3)

A4(210 X 297)



HYDIS

PRODUCT GROUP

REV

ISSUE DATE

TFT LCD PRODUCT

A

2011. 05. 25

15.2 Pallet Packing

T.B.D

SPEC. NUMBER

SPEC TITLE

HV101WX1-1E1 Preliminary Product Specification for Customer

PAGE

30 OF 33

B2005-C001-D (3/3)

A4(210 X 297)



PRODUCT GROUP

REV

ISSUE DATE

TFT LCD PRODUCT

A

2011. 05. 25

16.0 EDID Data

Address (HEX)	Function	Hex	Dec	Input values.	Notes
00	Header	00	0	0	EDID Header
01		FF	255	255	
02		FF	255	255	
03		FF	255	255	
04		FF	255	255	
05		FF	255	255	
06		FF	255	255	
07		00	0	0	
08	ID Manufacturer Name	23	35	HYD	ID = HYD
09		24	36		
0A	ID Product Code	4E	78	1102	ID = 1102
0B		04	4		
0C	32-bit serial No.	00	0		
0D		00	0		
0E		00	0		
0F		00	0		
10	Week of manufacture	0	0	0	
11	Year of Manufacture	15	21	2011	Manufactured in 2011
12	EDID Structure Ver.	01	1	1	EDID Ver 1.0
13	EDID revision #	03	3	3	EDID Rev. 0.3
14	Video input definition	80	128	-	
15	Max H image size	16	22	22	22 cm (Approx)
16	Max V image size	0E	14	14	14 cm (Approx)
17	Display Gamma	78	120	2.2	Gamma curve = 2.2
18	Feature support	0A	10		RGB display, Preferred Timming mode
19	Red/Green low bits	E0	224	-	Red / Green Low Bits
1A	Blue/White low bits	A5	165	-	Blue / White Low Bits
1B	Red x high bits	99	153	0.601	Red (x) = 10011001 (0.601)
1C	Red y high bits	55	85	0.334	Red (y) = 01010101 (0.334)
1D	Green x high bits	54	84	0.328	Green (x) = 01010100 (0.328)
1E	Green y high bits	92	146	0.570	Green (y) = 10010010 (0.57)
1F	Blue x high bits	27	39	0.154	Blue (x) = 00100111 (0.154)
20	Blue y high bits	1E	30	0.119	Blue (y) = 00011110 (0.119)
21	White x high bits	50	80	0.313	White (x) = 01010000 (0.313)
22	White y high bits	54	84	0.329	White (y) = 01010100 (0.329)
23	Established timing 1	00	0	-	
24	Established timing 2	00	0	-	
25	Established timing 3	00	0	-	
26	Standard timing #1	01	1		Not Used
27		01	1		
28	Standard timing #2	01	1		Not Used
29		01	1		
2A	Standard timing #3	01	1		Not Used
2B		01	1		
2C	Standard timing #4	01	1		Not Used
2D		01	1		
2E	Standard timing #5	01	1		Not Used
2F		01	1		

SPEC. NUMBER

SPEC TITLE

HV101WX1-1E1 Preliminary Product Specification for Customer

PAGE

31 OF 33

B2005-C001-D (3/3)

A4(210 X 297)



PRODUCT GROUP

REV

ISSUE DATE

TFT LCD PRODUCT

A

2011. 05. 25

Address (HEX)	Function	Hex	Dec	Input values.	Notes	
30	Standard timing #6	01	1		Not Used	
31		01	1			
32	Standard timing #7	01	1		Not Used	
33		01	1			
34	Standard timing #8	01	1		Not Used	
35		01	1			
36	Detailed timing/monitor descriptor #1	C6	198	71.1000	71.1MHz Main clock	
37		1B	27			
38		00	0	1280	Hor Active = 1280	
39		A0	160	160	Hor Blanking = 160	
3A		50	80	-	4 bits of Hor. Active + 4 bits of Hor. Blanking	
3B		20	32	800	Ver Active = 768	
3C		17	23	23	Ver Blanking = 23	
3D		30	48	-	4 bits of Ver. Active + 4 bits of Ver. Blanking	
3E		30	48	48	Hor Sync Offset = 48	
3F		20	32	32	H Sync Pulse Width = 32	
40		36	54	3	V sync Offset = 3 line	
41		00	0	6	V Sync Pulse width : 6 line	
42		DC	220	220	Horizontal Image Size = 220 mm (Low 8 bits)	
43		8C	140	140	Vertical Image Size = 140 mm (Low 8 bits)	
44		00	0	-	4 bits of Hor Image Size + 4 bits of Ver Image Size	
45		00	0	0	Hor Border (pixels)	
46		00	0	0	Vertical Border (Lines)	
47		19	25		Refer to right table	
48		Detailed timing/monitor descriptor #2	00	0		
49			00	0		
4A	00		0			
4B	FE		254			
4C	00		0			
4D	0A		10			
4E	20		32			
4F	20		32			
50	20		32			
51	20		32			
52	20		32			
53	20		32			
54	20	32				
55	20	32				
56	20	32				
57	20	32				
58	20	32				
59	20	32				

SPEC. NUMBER

SPEC TITLE

HV101WX1-1E1 Preliminary Product Specification for Customer

PAGE

32 OF 33

B2005-C001-D (3/3)

A4(210 X 297)



PRODUCT GROUP

REV

ISSUE DATE

TFT LCD PRODUCT

A

2011. 05. 25

Address (HEX)	Function	Hex	Dec	Input values.	Notes
5A	Detailed timing/monitor descriptor #3	00	0		
5B		00	0		
5C		00	0		
5D		FE	254		
5E		00	0		
5F		48	72	H	
60		59	89	Y	
61		44	68	D	
62		49	73	I	
63		53	83	S	
64		0A	10		
65		20	32		
66		20	32		
67		20	32		
68		20	32		
69		20	32		
6A	20	32			
6B	20	32			
6C	Detailed timing/monitor descriptor #4	00	0		
6D		00	0		
6E		00	0		
6F		FE	254		
70		00	0		
71		48	72	H	
72		56	86	V	
73		31	49	1	
74		30	48	0	
75		31	49	1	
76		57	87	W	
77		58	88	X	
78		31	49	1	
79		2D	45	-	
7A		31	49	1	
7B		45	69	E	
7C	30	48	0		
7D	0A	10			
7E	Extension flag	00	0		
7F	Checksum	C1	193	-	

SPEC. NUMBER

SPEC TITLE

HV101WX1-1E1 Preliminary Product Specification for Customer

PAGE

33 OF 33