



# SmarterGlass

state-of-the-art display solutions

[www.smarterglass.com](http://www.smarterglass.com)  
978 997 4104  
[sales@smarterglass.com](mailto:sales@smarterglass.com)



**PROPRIETARY NOTE**

THIS SPECIFICATION IS THE PROPERTY OF BOE HYDIS AND SHALL NOT BE REPRODUCED OR COPIED WITHOUT THE WRITTEN PERMISSION OF BOE HYDIS AND MUST BE RETURNED TO BOE HYDIS UPON ITS REQUEST

**TITLE : HV121WX4-100**

**Product Specification**

**Rev. 0**

**BOE HYDIS TECHNOLOGY**

<b>SPEC. NUMBER</b> S864-1326	<b>PRODUCT GROUP</b> TFT-LCD PRODUCTS	<b>REV.</b> 0	<b>ISSUE DATE</b> 2007. 02. 15	<b>PAGE</b> 1 OF 30
----------------------------------	------------------------------------------	------------------	-----------------------------------	------------------------





PRODUCT GROUP

REV

ISSUE DATE

TFT-LCD PRODUCT

0

2007.02.15

## Contents

No	Item	Page
1.0	General Description ..	4
2.0	Absolute Maximum ratings.....	6
3.0	Electrical specifications .....	7
4.0	Optical specifications .....	8
5.0	Interface Connection .....	10
6.0	Signal Timing Specification .....	12
7.0	Signal Timing waveforms of interface signal (DE mode) .....	14
8.0	Input Signals, Display Colors & Gray Scale of Colors .....	15
9.0	Power Sequence .....	16
10.0	Mechanical Characteristics .....	17
11.0	Reliability Test .....	18
12.0	Handling & Cautions .....	19
13.0	Packing .....	20
14.0	Environment & Safety.....	21
15.0	Appendix .....	23
16.0	EDID Data .....	27

SPEC. NUMBER  
S864-1326

SPEC. TITLE  
HV121WX4-100 Product Specification

PAGE  
3 OF 30

## 1.0 GENERAL DESCRIPTION

### 1.1 Introduction

HV121WX4-100 is a color active matrix TFT LCD module using amorphous silicon TFT's (Thin Film Transistors) as an active switching devices. This module has a 12.1 inch diagonally measured active area with WXGA resolutions (1280 horizontal by 800 vertical pixel array). Each pixel is divided into RED, GREEN, BLUE dots which are arranged in vertical stripe and this module can display 262,144 colors. The TFT-LCD panel used for this module is a low reflection and higher color type.

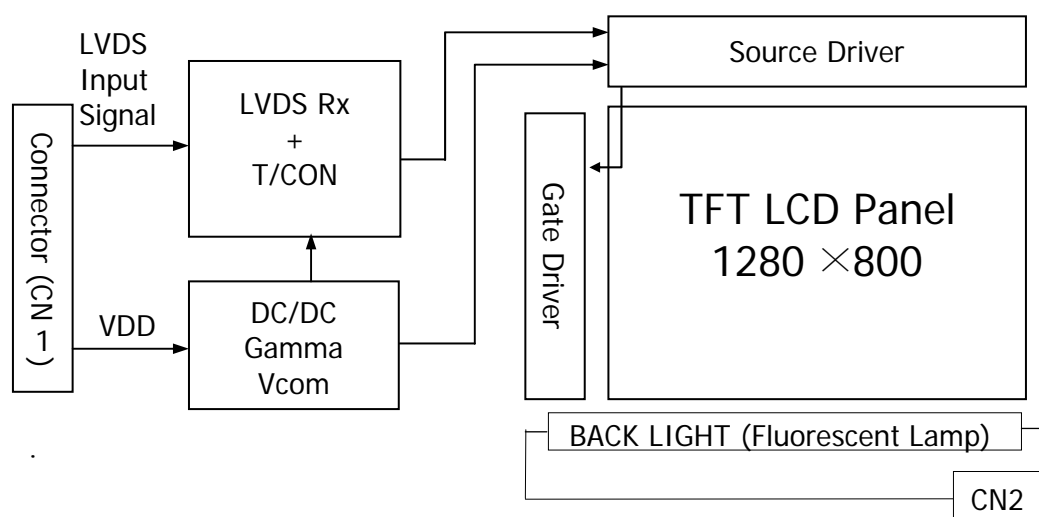

### 1.2 Features

- Thin and light weight
- 3.3 V power supply
- Low driving voltage and low power consumption
- 1 Channel LVDS Interface
- Single CCFL (Bottom side/Horizontal Direction)
- 262,144 colors
- Data enable signal mode
- Side Mounting Frame
- On Board EDID chip
- RoHS Product
- VESA V2 Compatible except for thickness
- Anti-Reflection polarizer product for sunlight readability

**PRODUCT GROUP**

REV

ISSUE DATE

TFT-LCD PRODUCT

O

2007.02.15

**1.3 Application**

- Tablet PC

**1.4 General Specifications**

&lt;Table 1. General Specifications&gt;

Parameter	Specification	Unit	Remarks
Active area	261.12 (H) × 163.20 (V)	mm	
Number of pixels	1280 (H) × 800 (V)	pixels	
Pixel pitch	0.204 (H) × 0.204 (V)	mm	
Pixel arrangement	RGB Vertical stripe		
Display colors	262,144	colors	
Display mode	Normally Black		
Dimensional outline	275.8±0.5(W) × 178.0±0.5(V) × 6.4 Typ D (6.7 Max)	mm	
Luminance of White	200 (Typ.)	Cd/m <sup>2</sup>	at 5points
Weight	290 (Typ.) / 300 (Max.)	g	
EBL	3.0 (Typ.)	W	At 60nit
Back-light	CCFL, Horizontal-lamp type		Note 1

Note 1: CCFL (Cold Cathode Fluorescent Lamp)

SPEC. NUMBER  
S864-1326SPEC. TITLE  
HV121WX4-100 Product SpecificationPAGE  
5 OF 30

## 2.0 ABSOLUTE MAXIMUM RATINGS

The followings are maximum values which, if exceed, may cause faulty operation or damage to the unit.

< Table 2. Absolute Maximum Ratings >

Parameter	Symbol	Min.	Max.	Unit	Remarks
Logic Power Supply	$V_{DD}$	VSS-0.3	4.0	V	Ta = 25 ± 2 °C
Logic Input Voltage	$V_{IN}$	VSS-0.3	$V_{DD}+0.3$	V	
Back-light Lamp Current	IBL	2.0	7.0	mA	
Back-light Frequency	FBL	45	80	KHz	
Operating Temperature	$T_{OP}$	0	+50	°C	Note 1
Storage Temperature	$T_{SP}$	-20	+60	°C	

Note 1. Temperature and relative humidity range are shown in the figure below.

\* 90 [%] RH Max. ( $40^{\circ}\text{C} \geq T_a$ )

\* Maximum wet-bulb temperature at 39 °C or less. ( $T_a > 40^{\circ}\text{C}$ ) No condensation

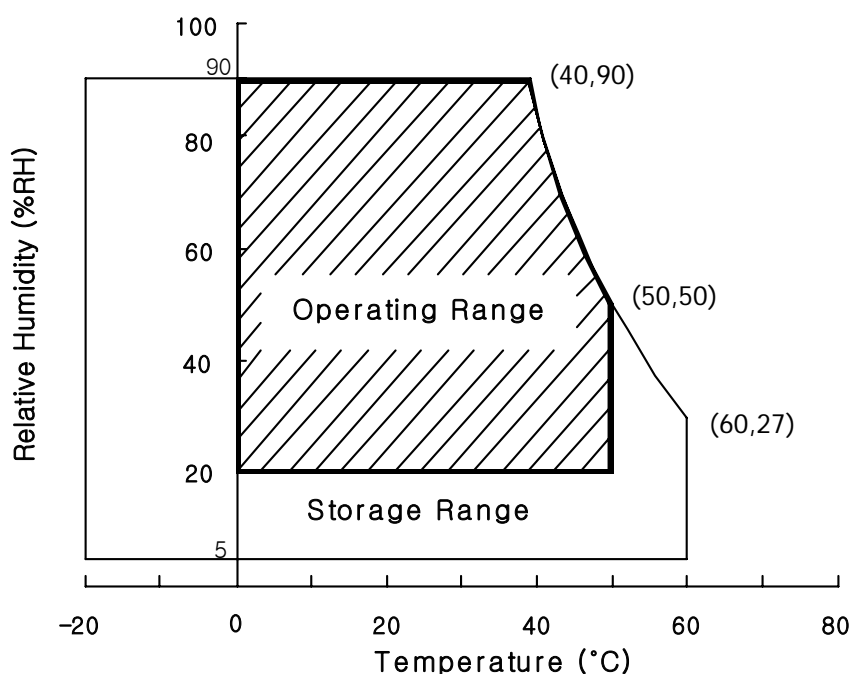



# PRODUCT GROUP

REV

ISSUE DATE

TFT-LCD PRODUCT

0

2007.02.15

## 3.0 ELECTRICAL SPECIFICATIONS

### 3.1 Electrical Specifications

< Table 3. Electrical specifications >

[Ta = 25±2℃]

Parameter		Min.	Typ.	Max.	Unit	Remarks
Power Supply Voltage	V <sub>DD</sub>	3.0	3.3	3.6	V	Note1
Power Supply Current	I <sub>DD</sub>		330		mA	Note1
CCFL Ignition Time	t			1	sec	
High Level Differential Input Signal Voltage	V <sub>IH</sub>		-	+100	mV	
Low Level Differential Input Signal Voltage	V <sub>IL</sub>	-100	-		mV	
Back-light Lamp Voltage	V <sub>BL</sub>	760	580	540	V <sub>rms</sub>	Note2
Back-light Lamp Current	I <sub>BL</sub>	2.0	6.0	7.0	mA	
Back-light Lamp operating Frequency	F <sub>L</sub>	45		80	KHz	One Lamp, Note3
Lamp Start Voltage		1,120			V <sub>rms</sub>	At Ta=25℃, Note4
		1,350			V <sub>rms</sub>	At Ta=0℃, Note4
Lamp Life		10,000	15,000		Hrs	I <sub>BL</sub> = 7mA, Note5
Extended Battery Life	P <sub>D</sub>		1.0		W	At Mosaic pattern
	P <sub>BL</sub>		2.0		W	At 60nit
	P <sub>total</sub>		3.0		W	
Power Consumption	P <sub>D</sub>		1.1		W	Note1
	P <sub>BL</sub>		3.5	3.85	W	I <sub>BL</sub> = 6mA, Note6
	P <sub>total</sub>		4.6		W	

- Notes :
- The supply voltage is measured and specified at the interface connector of LCM.  
The current draw and power consumption specified is for 3.3V at 25℃.  
a) Typ: Windows XP desktop Pattern      b) Max: V2 Skip Pattern
  - Reference value, which is measured with Samsung Electric SIC-180 Inverter.  
(VBL Min is value at IBL Min and VBL Max is value at IBL Max)
  - The lamp frequency should be selected as different as possible from the horizontal synchronous frequency and its harmonics to avoid interference which may cause line flow on the display.
  - For starting the backlight unit, the output voltage of DC/AC's transformer should be larger than the minimum lamp starting voltage.(1,120 Vrms at 25℃ & 1,350 Vrms at 0℃)  
If an inverter has shutdown function it should keep its output for more than 1 second even if the lamp connector open. Otherwise the lamps may not to be turned on.
  - End of Life shall be determined by the time when any of the following is satisfied under continuous lighting at 25℃ and IBL = 7.0[mA].  
• Intensity drops to 50% of the Initial Value.
  - Calculated value for reference (VBL × IBL)

SPEC. NUMBER  
S864-1326

SPEC. TITLE  
HV121WX4-100 Product Specification

PAGE  
7 OF 30





# PRODUCT GROUP

REV

ISSUE DATE

TFT-LCD PRODUCT

0

2007.02.15

## 4.0 OPTICAL SPECIFICATION

### 4.1 Overview

The test of Optical specifications shall be measured in a dark room (ambient luminance  $\leq 1$  lux and temperature =  $25 \pm 2^\circ\text{C}$ ) with the equipment of Luminance meter system (Goniometer system and TOPCONE BM-5) and test unit shall be located at an approximate distance 50cm from the LCD surface at a viewing angle of  $\Theta$  and  $\Phi$  equal to  $0^\circ$ . We refer to  $\Theta_{\theta=0}$  ( $= \Theta_3$ ) as the 3 o'clock direction (the "right"),  $\Theta_{\theta=90}$  ( $= \Theta_{12}$ ) as the 12 o'clock direction ("upward"),  $\Theta_{\theta=180}$  ( $= \Theta_9$ ) as the 9 o'clock direction ("left") and  $\Theta_{\theta=270}$  ( $= \Theta_6$ ) as the 6 o'clock direction ("bottom"). While scanning  $\Theta$  and/or  $\Phi$ , the center of the measuring spot on the Display surface shall stay fixed. The backlight should be operating for 30 minutes prior to measurement... VDD shall be  $3.3 \pm 0.3\text{V}$  at  $25^\circ\text{C}$ . Optimum viewing angle direction is 6 o'clock.

### 4.2 Optical Specifications

<Table 4. Optical Specifications>

Parameter		Symbol	Condition	Min.	Typ.	Max.	Unit	Remark
Viewing Angle range	Horizontal	$\Theta_3$	CR > 10		89	90	Deg.	Note 1
		$\Theta_9$			89	90	Deg.	
	Vertical	$\Theta_{12}$			89	90	Deg.	
		$\Theta_6$			89	90	Deg.	
Luminance Contrast ratio		CR	$\Theta = 0^\circ$		500			Note 2
Luminance of White	5 Points	$Y_w$	$\Theta = 0^\circ$ IBL = 6mA		200		cd/m <sup>2</sup>	
White Luminance uniformity	5 Points	$\Delta Y5$		80	85		%	Note 3
	13 Points	$\Delta Y13$		65	75			
White Chromaticity		$x_w$	$\Theta = 0^\circ$	-	0.313	-		Note 4
		$y_w$		-	0.329	-		
Reproduction Of color	Red	$x_R$	$\Theta = 0^\circ$		0.584			
		$y_R$			0.340			
	Green	$x_G$			0.302			
		$y_G$			0.553			
	Blue	$x_B$			0.146			
		$y_B$			0.141			
Response Time	Rise	$T_r$	Ta = $25^\circ\text{C}$ $\Theta = 0^\circ$		28		ms	Note 5
	Decay	$T_d$						
Cross Talk		CT	$\Theta = 0^\circ$			2.0	%	Note 6

SPEC. NUMBER  
S864-1326

SPEC. TITLE  
HV121WX4-100 Product Specification

PAGE  
8 OF 30



PRODUCT GROUP

REV

ISSUE DATE

TFT-LCD PRODUCT

0

2007.02.15

Note :

1. Viewing angle is the angle at which the contrast ratio is greater than 10. The viewing are determined for the horizontal or 3, 9 o'clock direction and the vertical or 6, 12 o'clock direction with respect to the optical axis which is normal to the LCD surface (see FIGURE 1 shown in Appendix).
2. Contrast measurements shall be made at viewing angle of  $\Theta = 0^\circ$  and at the center of the LCD surface. Luminance shall be measured with all pixels in the view field set first to white, then to the dark (black) state. (See FIGURE 1 shown in Appendix) Luminance Contrast Ratio (CR) is defined mathematically.

$$CR = \frac{\text{Luminance when displaying a white raster}}{\text{Luminance when displaying a black raster}}$$

3. The White luminance uniformity on LCD surface is then expressed. (See FIGURE 2 shown in Appendix).

$$\text{Uniformity } \Delta Y = \frac{\text{Minimum Luminance of 5(or 13) points}}{\text{Maximum Luminance of 5(or 13) points}} \times 100 (\%)$$

4. The color chromaticity coordinates specified in Table 4 shall be calculated from the spectral data measured with all pixels first in red, green, blue and white. Measurements shall be made at the center of the panel.
5. The electro-optical response time measurements shall be made as FIGURE 3 shown in Appendix by switching the "data" input signal OFF and ON. The times needed for the luminance to change from 10% to 90% is Tr, and 90% to 10% is Td.
6. Cross-Talk of one area of the LCD surface by another shall be measured by comparing the luminance (YA) of a 25mm diameter area, with all display pixels set to a gray level, to the luminance (YB) of that same area when any adjacent area is driven dark. (See FIGURE 4 shown in Appendix).

SPEC. NUMBER  
S864-1326

SPEC. TITLE  
HV121WX4-100 Product Specification

PAGE  
9 OF 30



## PRODUCT GROUP

REV

ISSUE DATE

TFT-LCD PRODUCT

O

2007.02.15

### 5.0 INTERFACE CONNECTION.

#### 5.1 Electrical Interface Connection

<Table 5. Pin Assignments for the Interface Connector>

CN1	Interface connector	Hirose/DF19KR-20P-1H or equivalent
	User side connector	Hirose/DF19G-20S-1C or equivalent

Pin No	Symbol	Function	Remark
1	VSS	Ground	
2	VDD1	Power Supply: +3.3V	
3	VDD2	Power Supply: +3.3V	
4	Vdd_EDID	EDID +3.3V	
5	NC	Reserved	
6	Clk_EDID	EDID Clk	
7	Clk_Data	EDID Data	
8	RIN0-	LVDS Negative data signal (-)	Tx pin # 48
9	RIN0+	LVDS Positive data signal (+)	Tx pin # 47
10	VSS	Ground	
11	RIN1-	LVDS Negative data signal (-)	Tx pin # 46
12	RIN1+	LVDS Positive data signal (+)	Tx pin # 45
13	VSS	Ground	
14	RIN2-	LVDS Negative data signal (-)	Tx pin # 42
15	RIN2+	LVDS Positive data signal (+)	Tx pin # 41
16	VSS	Ground	
17	RCLKIN-	LVDS Negative clock signal (-)	Tx pin # 40
18	RCLKIN+	LVDS Positive clock signal (+)	Tx pin # 39
19	VSS	Ground	
20	VSS	Ground	

SPEC. NUMBER  
S864-1326

SPEC. TITLE  
HV121WX4-100 Product Specification

PAGE  
10 OF 30



# PRODUCT GROUP

REV

ISSUE DATE

TFT-LCD PRODUCT

0

2007.02.15

## 5.2. Back-light Interface

CN2	Interface Connector	•: BHSR-02VS-1 (JST) or equivalent
-----	---------------------	------------------------------------

Pin No	INPUT	Function	Remarks
1	HOT	High voltage	Pink
2	COLD	Ground	Black

## 5.3. LVDS Interface

LVDS Transmitter: THC63LVDM83A or equivalent.

Input signal	Transmitter		Interface		DF19KR-20P-1H	Remark
	Pin No	Pin No	System (Tx)	TFT-LCD (Rx)	Pin No.	
R0	51	48 47	OUT0- OUT0+	IN0- IN0+	5 6	
R1	52					
R2	54					
R3	55					
R4	56					
R5	3					
G0	4	46 45	OUT1- OUT1+	IN1- IN1+	8 9	
G1	6					
G2	7					
G3	11					
G4	12					
G5	14					
B0	15	42 41	OUT2- OUT2+	IN2- IN2+	11 12	
B1	19					
B2	20					
B3	22					
B4	23					
B5	24					
HSYNC	27	40	CLKOUT-	CLKIN-	14	
VSYNC	28					
DE	30					
MCLK	31	39	CLKOUT+	CLKIN+	15	

SPEC. NUMBER  
S864-1326

SPEC. TITLE  
HV121WX4-100 Product Specification

PAGE  
11 OF 30

**5.4. Data Input Format**

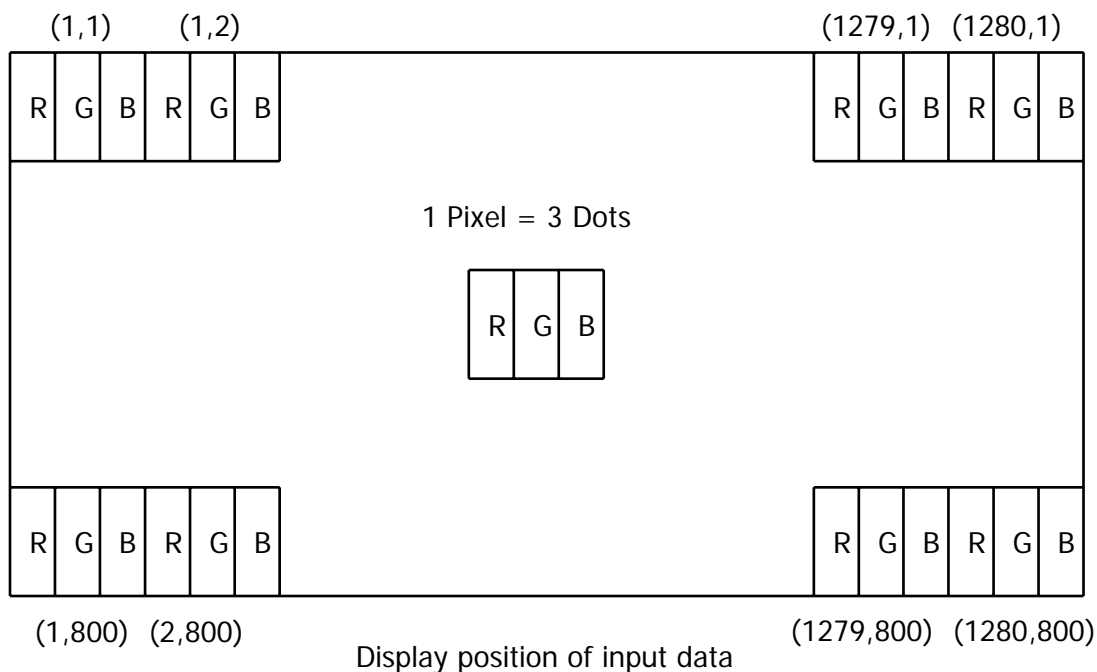

**6.0. SIGNAL TIMING SPECIFICATIONS**

**6.1 HV121WX4-100 is operated by the only DE (Data enable) mode (LVDS Transmitter Input)**

Item	Symbols	Min	Typ	Max	Unit
Frame Period	T1	804	823	-	lines
Vertical Display Period	T2	-	800	-	lines
One Line Scanning Period	T3	1350	1440	-	clocks
Horizontal Display Period	T4	-	1280	-	clocks
Clock Frequency	1/T5	-	71.11	-	MHz

### 6.2. LVDS Rx interface timing parameter

The specification of the LVDS Rx interface timing parameter

<LVDS Rx Interface Timing Specification>

Item	Symbol	Min	Typ	Max	Unit	Remark
CLKIN Period	tRCIP	12.5	14.06	25.00	nsec	
Input Data 0	tRIP0	-0.4	0.0	+0.4	nsec	
Input Data 1	tRIP1	tRCIP/7-0.4	tRCIP/7	tRCIP/7+0.4	nsec	
Input Data 2	tRIP2	2 × tRCIP/7-0.4	2 × tRCIP/7	2 × tRCIP/7+0.4	nsec	
Input Data 3	tRIP3	3 × tRCIP/7-0.4	3 × tRCIP/7	3 × tRCIP/7+0.4	nsec	
Input Data 4	tRIP4	4 × tRCIP/7-0.4	4 × tRCIP/7	4 × tRCIP/7+0.4	nsec	
Input Data 5	tRIP5	5 × tRCIP/7-0.4	5 × tRCIP/7	5 × tRCIP/7+0.4	nsec	
Input Data 6	tRIP6	6 × tRCIP/7-0.4	6 × tRCIP/7	6 × tRCIP/7+0.4	nsec	

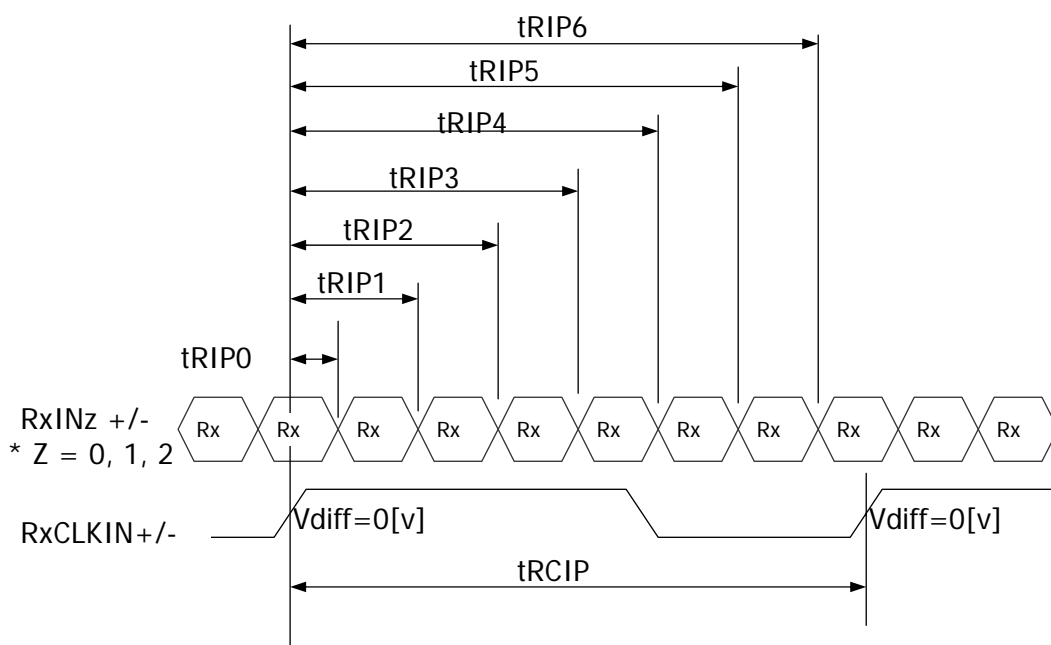

\* Vdiff = (RINz+)-(RINz-), (RCLKIN+)-(RCLKIN-)

## 7.0 SIGNAL TIMING WAVEFORMS OF INTERFACE SIGNAL (DE MODE)

### 7.1 Timing Waveforms of Interface Signal

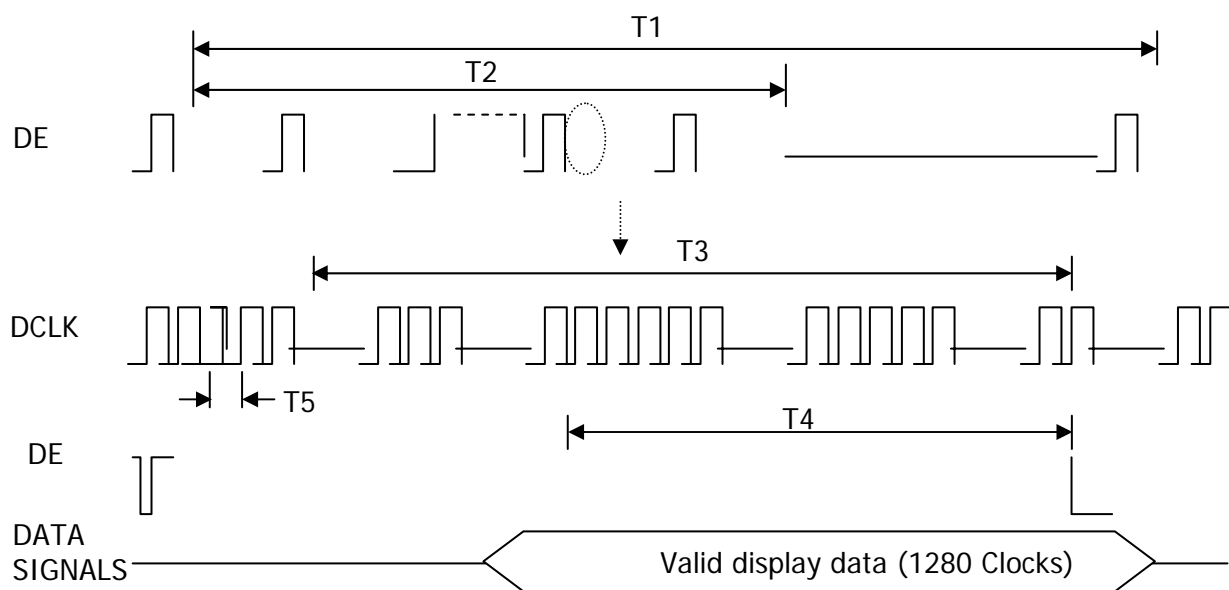



# PRODUCT GROUP

REV

ISSUE DATE

TFT-LCD PRODUCT

0

2007.02.15

## 8.0 INPUT SIGNALS, BASIC DISPLAY COLORS & GRAY SCALE OF COLORS

Each color is displayed in sixty-four gray scales from a 6 bit data signal input. A total of 262,144 colors are derived from the resultant 18 bit data.

Colors & Gray Scale		Red Data						Green Data						Blue Data					
		R5	R4	R3	R2	R1	R0	G5	G4	G3	G2	G1	G0	B5	B4	B3	B2	B1	B0
Basic Colors	Black	0	0	0	0	0	0	0	0	0	0	0	0	0	0	0	0	0	0
	Blue	0	0	0	0	0	0	0	0	0	0	0	0	1	1	1	1	1	1
	Green	0	0	0	0	0	0	1	1	1	1	1	1	0	0	0	0	0	0
	Cyan	0	0	0	0	0	0	1	1	1	1	1	1	1	1	1	1	1	1
	Red	1	1	1	1	1	1	0	0	0	0	0	0	0	0	0	0	0	0
	Magenta	1	1	1	1	1	1	0	0	0	0	0	0	1	1	1	1	1	1
	Yellow	1	1	1	1	1	1	1	1	1	1	1	1	0	0	0	0	0	0
	White	1	1	1	1	1	1	1	1	1	1	1	1	1	1	1	1	1	1
Gray Scale Of Red	Black	0	0	0	0	0	0	0	0	0	0	0	0	0	0	0	0	0	0
	△	0	0	0	0	0	1	0	0	0	0	0	0	0	0	0	0	0	0
	Darker	0	0	0	0	1	0	0	0	0	0	0	0	0	0	0	0	0	0
	△	↓						↓						↓					
	▽	↓						↓						↓					
	Brighter	1	1	1	1	0	1	0	0	0	0	0	0	0	0	0	0	0	0
	▽	1	1	1	1	1	0	0	0	0	0	0	0	0	0	0	0	0	0
	Red	1	1	1	1	1	1	0	0	0	0	0	0	0	0	0	0	0	0
Gray Scale Of Green	Black	0	0	0	0	0	0	0	0	0	0	0	0	0	0	0	0	0	0
	△	0	0	0	0	0	0	0	0	0	0	0	1	0	0	0	0	0	0
	Darker	0	0	0	0	0	0	0	0	0	0	1	0	0	0	0	0	0	0
	△	↓						↓						↓					
	▽	↓						↓						↓					
	Brighter	0	0	0	0	0	0	1	1	1	1	0	1	0	0	0	0	0	0
	▽	0	0	0	0	0	0	1	1	1	1	1	0	0	0	0	0	0	0
	Green	0	0	0	0	0	0	1	1	1	1	1	1	0	0	0	0	0	0
Gray Scale Of Blue	Black	0	0	0	0	0	0	0	0	0	0	0	0	0	0	0	0	0	0
	△	0	0	0	0	0	0	0	0	0	0	0	0	0	0	0	0	0	1
	Darker	0	0	0	0	0	0	0	0	0	0	0	0	0	0	0	0	1	0
	△	↓						↓						↓					
	▽	↓						↓						↓					
	Brighter	0	0	0	0	0	0	0	0	0	0	0	0	1	1	1	1	0	1
	▽	0	0	0	0	0	0	0	0	0	0	0	0	1	1	1	1	1	0
	Blue	0	0	0	0	0	0	0	0	0	0	0	0	1	1	1	1	1	1
Gray Scale Of White & Black	Black	0	0	0	0	0	0	0	0	0	0	0	0	0	0	0	0	0	0
	△	0	0	0	0	0	1	0	0	0	0	0	1	0	0	0	0	0	1
	Darker	0	0	0	0	1	0	0	0	0	0	1	0	0	0	0	0	1	0
	△	↓						↓						↓					
	▽	↓						↓						↓					
	Brighter	1	1	1	1	0	1	1	1	1	1	0	1	1	1	1	1	0	1
	▽	1	1	1	1	1	0	1	1	1	1	1	0	1	1	1	1	1	0
	White	1	1	1	1	1	1	1	1	1	1	1	1	1	1	1	1	1	1

SPEC. NUMBER  
S864-1326

SPEC. TITLE  
HV121WX4-100 Product Specification

PAGE  
15 OF 30



## 9.0 POWER SEQUENCE

To prevent a latch-up or DC operation of the LCD module, the power on/off sequence shall be as shown in below

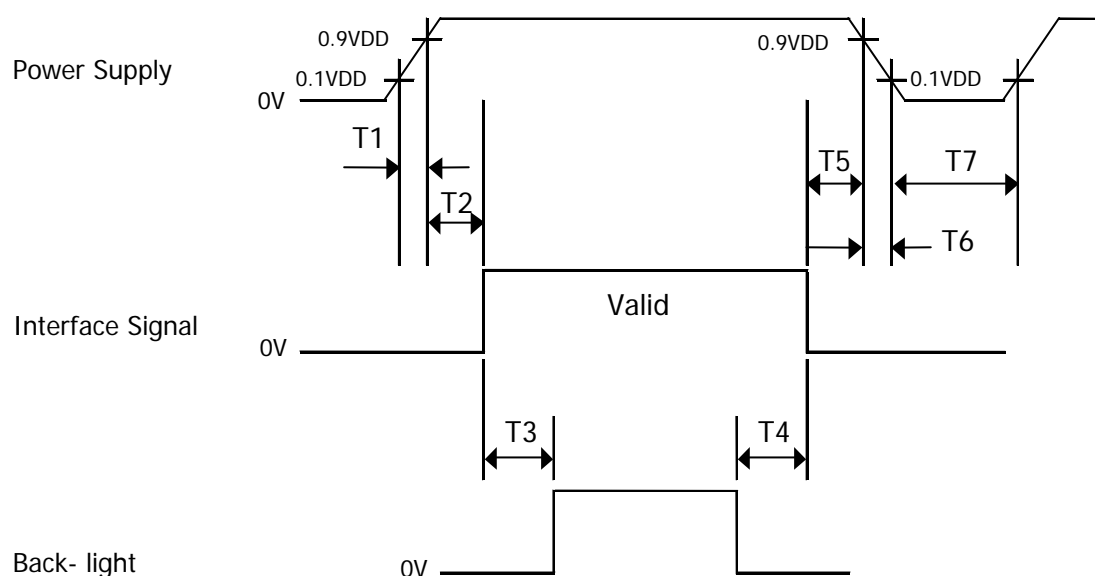

- $0 < T1 \leq 10 \text{ ms}$
- $0 < T2 \leq 50 \text{ ms}$
- $200 \text{ ms} \leq T3$
- $200 \text{ ms} \leq T4$
- $0 \leq T5 \leq 50 \text{ ms}$
- $0 \leq T6 \leq 10 \text{ ms}$
- $500 \text{ ms} \leq T7$

### Notes:

1. When the power supply VDD is 0V, Keep the level of input signals on the low or keep high impedance.
2. Do not keep the interface signal high impedance when power is on.
3. Back Light must be turn on after power for logic and interface signal are valid.

**PRODUCT GROUP**

REV

ISSUE DATE

TFT-LCD PRODUCT

O

2007.02.15

**10.0 MECHANICAL CHARACTERISTICS****10.1 Dimensional Requirements**

FIGURE 5, 6 shown in appendix shows mechanical outlines for the model.

Parameter	Specification	Unit
Active area	261.12 (H) × 163.20 (V)	mm
Number of pixels	1280(H) × 800(V)	pixels
	(1 pixel = R + G + B dots)	
Pixel pitch	0.204(H) × 0.204(V)	mm
Pixel arrangement	RGB Vertical stripe	
Display colors	262,144	colors
Display mode	Normally Black	
Dimensional outline	275.8±0.5(W) × 178.0±0.5(V) × 6.4 Typ D (6.7 Max)	mm
Weight	290 (Typ.) / 300 (Max.)	g
Back-light	CCFL, Horizontal-lamp type	

**10.2 Mounting**

See FIGURE 5. (shown in Appendix)

**10.3 Anti-Reflection Polarizer.**

The surface of the LCD has an anti-reflection coating to minimize reflection for sunlight readability.

**10.4 Light Leakage**

There shall not be visible light from the back-lighting system around the edges of the screen as seen from a distance 50 cm from the screen with an overhead light level of 150lux. The manufacture shall furnish limit samples of the panel showing the light leakage acceptable.

SPEC. NUMBER  
S864-1326

SPEC. TITLE  
HV121WX4-100 Product Specification

PAGE  
17 OF 30



PRODUCT GROUP

REV

ISSUE DATE

TFT-LCD PRODUCT

0

2007.02.15

## 11.0 RELIABILITY TEST

No	Test Items	Conditions
1	High temperature storage test	Ta = 60 °C, 240 hrs
2	Low temperature storage test	Ta = -20 °C, 240 hrs
3	High temperature & high humidity operation test	Ta = 50 °C, 80%RH, 240hrs
4	High temperature operation test	Ta = 50 °C, 240 hrs
5	Low temperature operation test	Ta = 0 °C, 240 hrs
6	Thermal shock	Ta = -20 °C ↔ 60 °C (30 min), 100 cycle
7	Vibration test (non-operating)	Frequency : 10~500Hz Gravity/AMP : 1.5G Period : X,Y,Z 30min
8	Shock test (non-operating)	Gravity : 220G Pulse width : 2ms, half sine wave ±X, ±Y, ±Z Once for each direction
9	Electro-Static Discharge Test (non-operating)	Air : 150pF, 330ohm, 15KV Contact : 150pF, 330ohm, 8KV

SPEC. NUMBER  
S864-1326

SPEC. TITLE  
HV121WX4-100 Product Specification

PAGE  
18 OF 30



## PRODUCT GROUP

REV

ISSUE DATE

TFT-LCD PRODUCT

0

2007.02.15

## 12.0 HANDLING & CAUTIONS

### 12.1 Cautions when taking out the module

- Pick the pouch only, when taking out module from a shipping package.

### 12.2 Cautions for handling the module

- As the electrostatic discharges may break the LCD module, handle the LCD module with care. Peel a protection sheet off from the LCD panel surface as slowly as possible.
- As the LCD panel and backlight element are made from fragile glass material, impulse and pressure to the LCD module should be avoided.
- As the surface of the polarizer is very soft and easily scratched, use a soft dry cloth without chemicals for cleaning.
- Do not pull the interface connector in or out while the LCD module is operating.
- Put the module display side down on a flat horizontal plane.
- Handle connectors and cables with care.

### 12.3 Cautions for the operation

- When the module is operating, do not lose MCLK, DE signals. If any one of these signals were lost, the LCD panel would be damaged.
- Obey the supply voltage sequence. If wrong sequence were applied, the module would be damaged.

### 12.4 Cautions for the atmosphere

- Dewdrop atmosphere should be avoided.
- Do not store and/or operate the LCD module in a high temperature and/or humidity atmosphere. Storage in an electro-conductive polymer-packing pouch and under relatively low temperature atmosphere is recommended.

### 12.5 Cautions for the module characteristics

- Do not apply fixed pattern data signal to the LCD module at product aging.
- Applying fixed pattern for a long time may cause image sticking.

### 12.6 Other cautions

- Do not disassemble and/or re-assemble LCD module.
- Do not re-adjust variable resistor or switch etc.
- When returning the module for repair or etc, please pack the module not to be broken.  
We recommend using the original shipping packages.

SPEC. NUMBER  
S864-1326

SPEC. TITLE  
HV121WX4-100 Product Specification

PAGE  
19 OF 30

## 13.0 PACKING

### 13.1 Packing Order

Put Pad into the box.

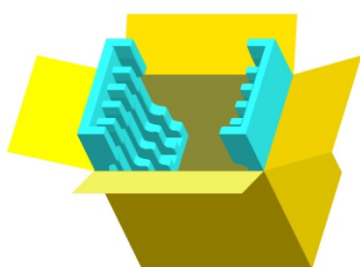

Put silica gels in the box.

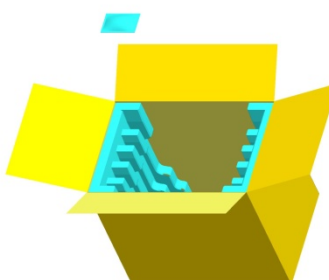

After sealing the box, attach Packing Label on the attach position sign area of the box.

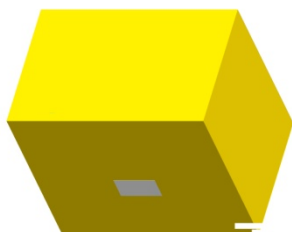

Place a cover on the top of the box.

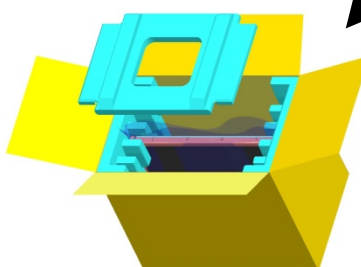

As shown in the figure, place the Modules bundled by shielding bag in the box.

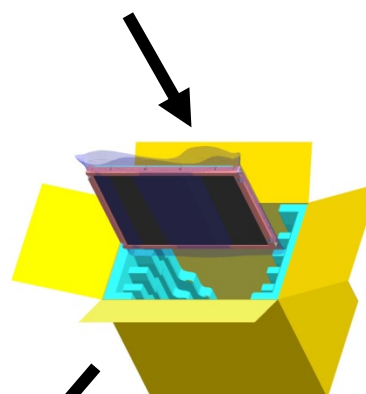

#### Notes

- Box Dimension: 261mm(W) X 349mm(D) X 311mm(H)
- Package Quantity in one Box: 10pcs



PRODUCT GROUP

REV

ISSUE DATE

TFT-LCD PRODUCT

0

2007.02.15

### 14.0 Environment & Safety

#### 14.1 Packing Label

Label Size: 108 mm (L) × 56 mm (W)

Contents

Model: HV121WX4-100

Q`ty: Module Q`ty in one box

Serial No.: Box Serial No. See next figure for detail description.

Date: Packing Date

FG Code: FG Code of Product

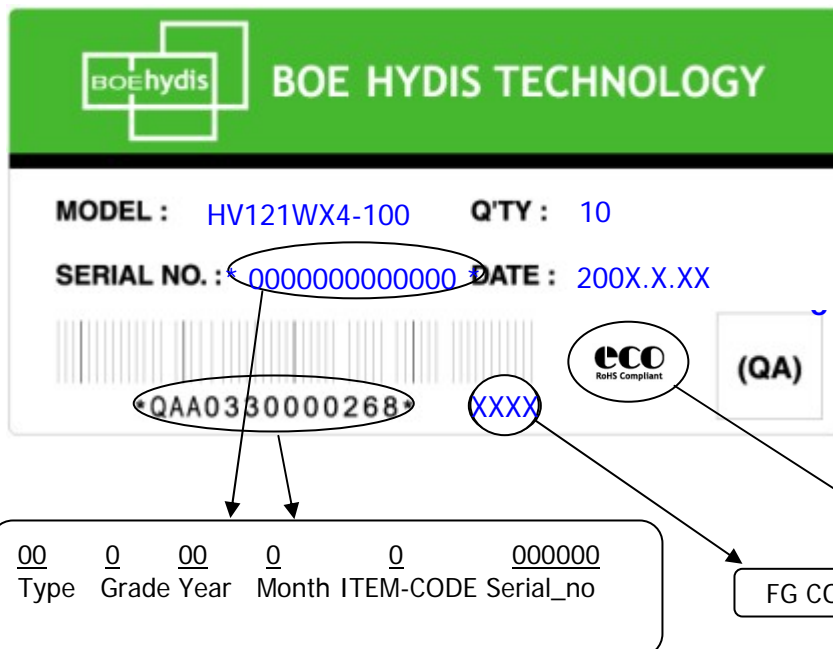

#### 14.2 Mercury disposal & High voltage caution

	HIGH VOLTAGE CAUTION	COLD CATHODE FLUORESCENT LAMP IN LCD PANEL CONTAINS A SMALL AMOUNT OF MERCURY. PLEASE FOLLOW LOCAL ORDINANCES OR REGULATIONS FOR DISPOSAL.
	RISK OF ELECTRIC SHOCK. DISCONNECT THE ELECTRIC POWER BEFORE SERVICING	

SPEC. NUMBER S864-1326	SPEC. TITLE HV121WX4-100 Product Specification	PAGE 21 OF 26
---------------------------	---------------------------------------------------	------------------



# PRODUCT GROUP

REV

ISSUE DATE

TFT-LCD PRODUCT

0

2007.02.15

## 14.3 Product Label



### BOE HYDIS Barcode

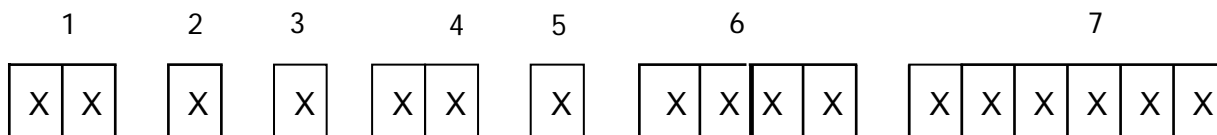

No 1. Control Number

No 2. Rank / Grade

No 3. Line Classification  
(BOE HYDIS : H, LCM : L, BOE OT : A/B/C)

No 4. Year (5 : 2005, 6 : 2006, ...)

No 5. Month (1, 2, 3, ..., 9, X, Y, Z)

No 6. FG Code

No 7. Serial Number

SPEC. NUMBER  
S864-1326

SPEC. TITLE  
HV121WX4-100 Product Specification

PAGE  
22 OF 30

15.0 APPENDIX

Figure 1. Measurement Set Up

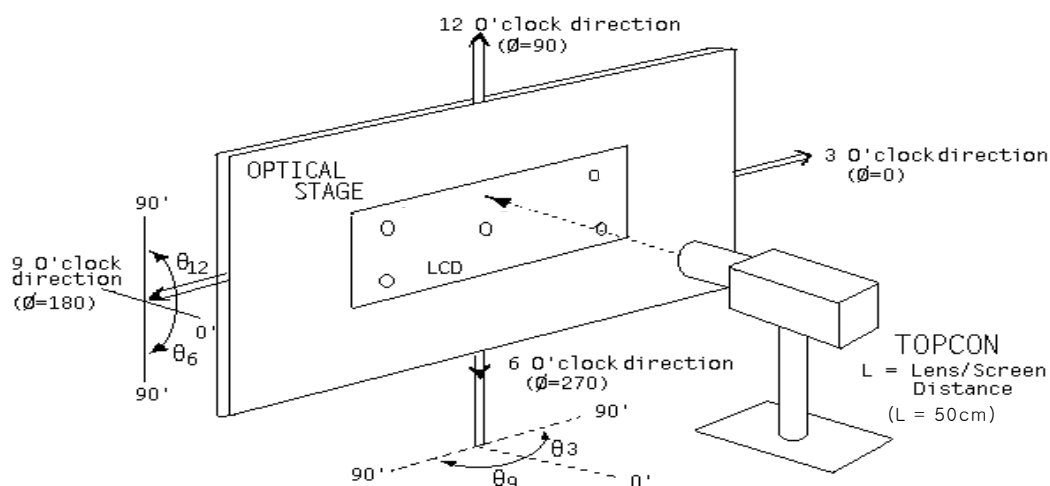

Figure 2. Average Luminance Measurement Locations & Uniformity Measurement Locations

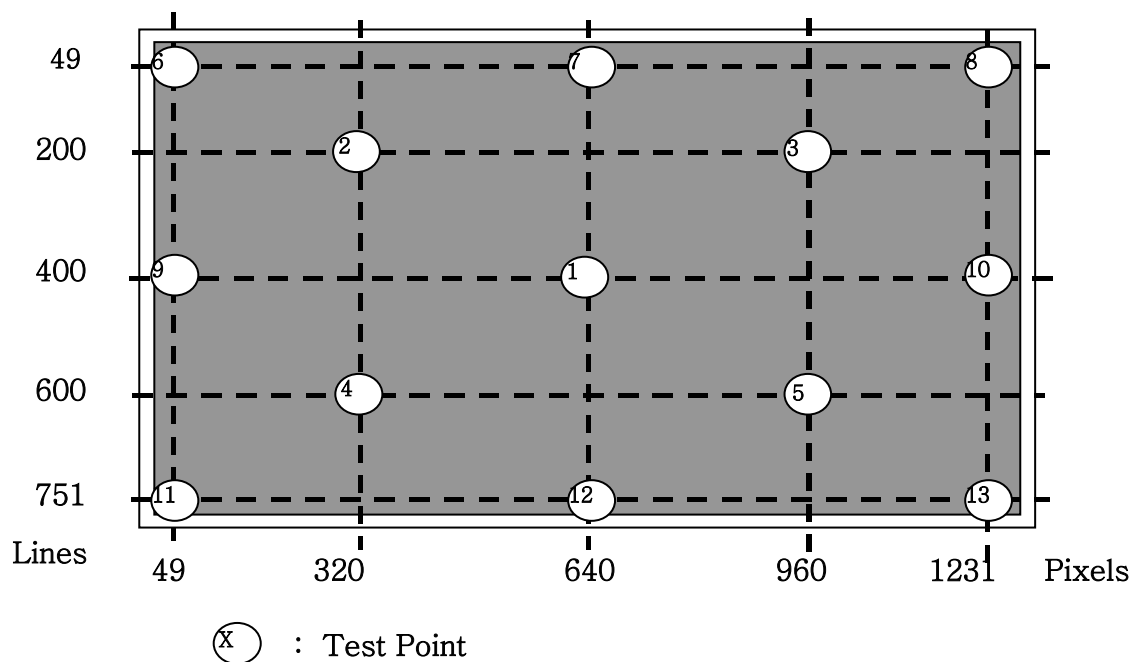



Figure 3. Response Time Testing

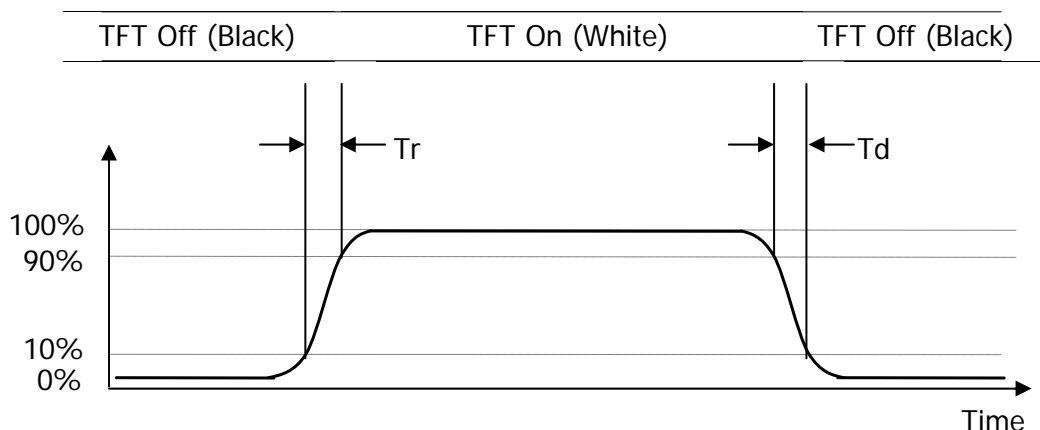
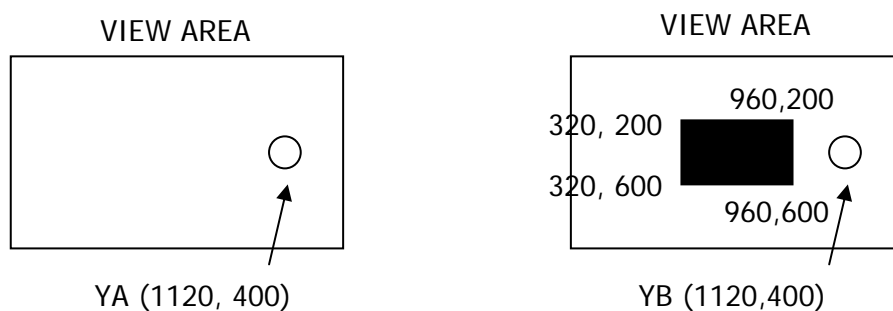

Figure 4. Cross Modulation Test Description



$$\text{Cross-Talk} = \frac{Y_B - Y_A}{Y_A} \times 100$$

Where:

$Y_A$  = Initial luminance of measured area (cd/m<sup>2</sup>)

$Y_B$  = Subsequent luminance of measured area (cd/m<sup>2</sup>)

The location measured will be exactly the same in both patterns.

Figure 5. TFT-LCD Module Outline Dimensions (Front view)

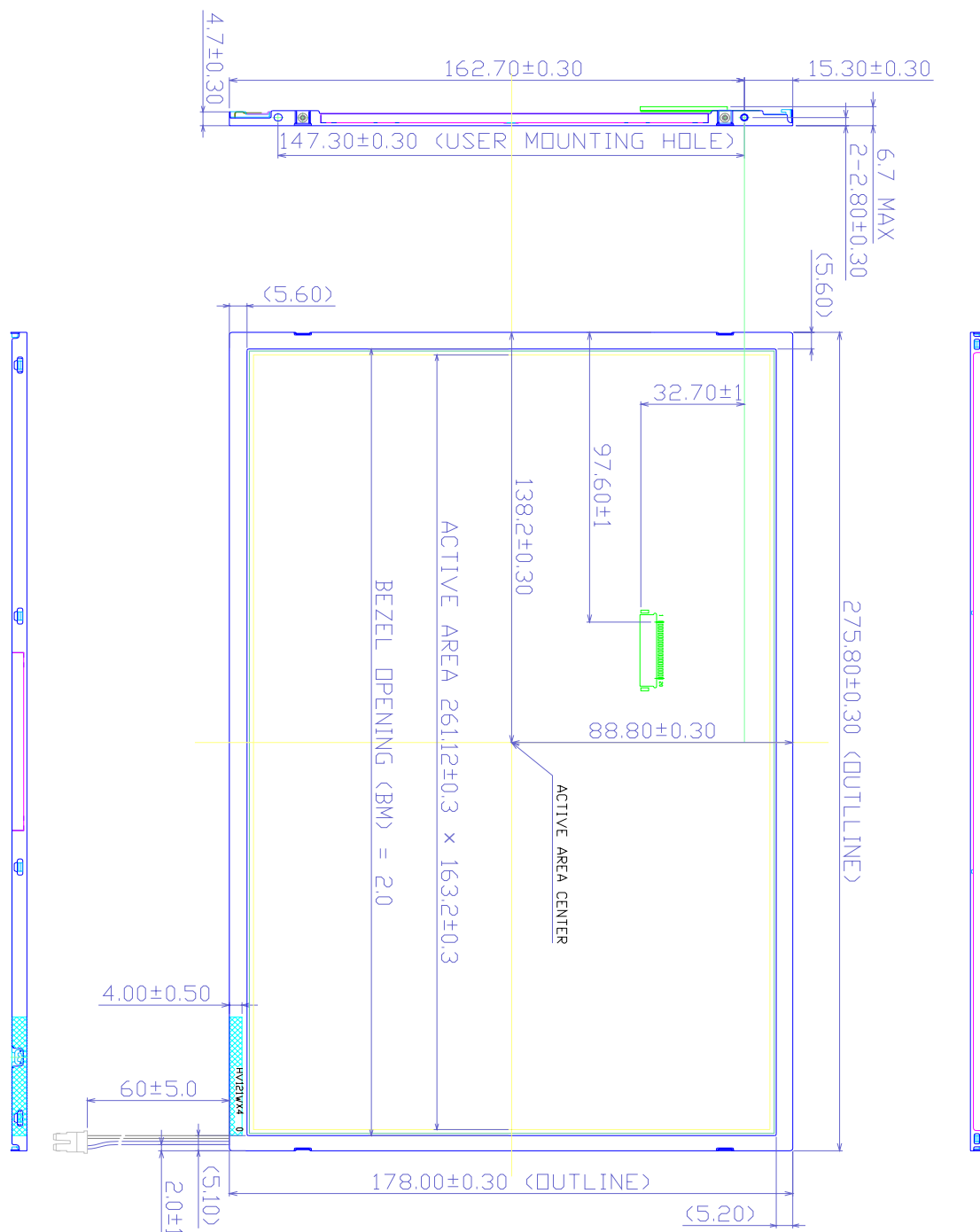

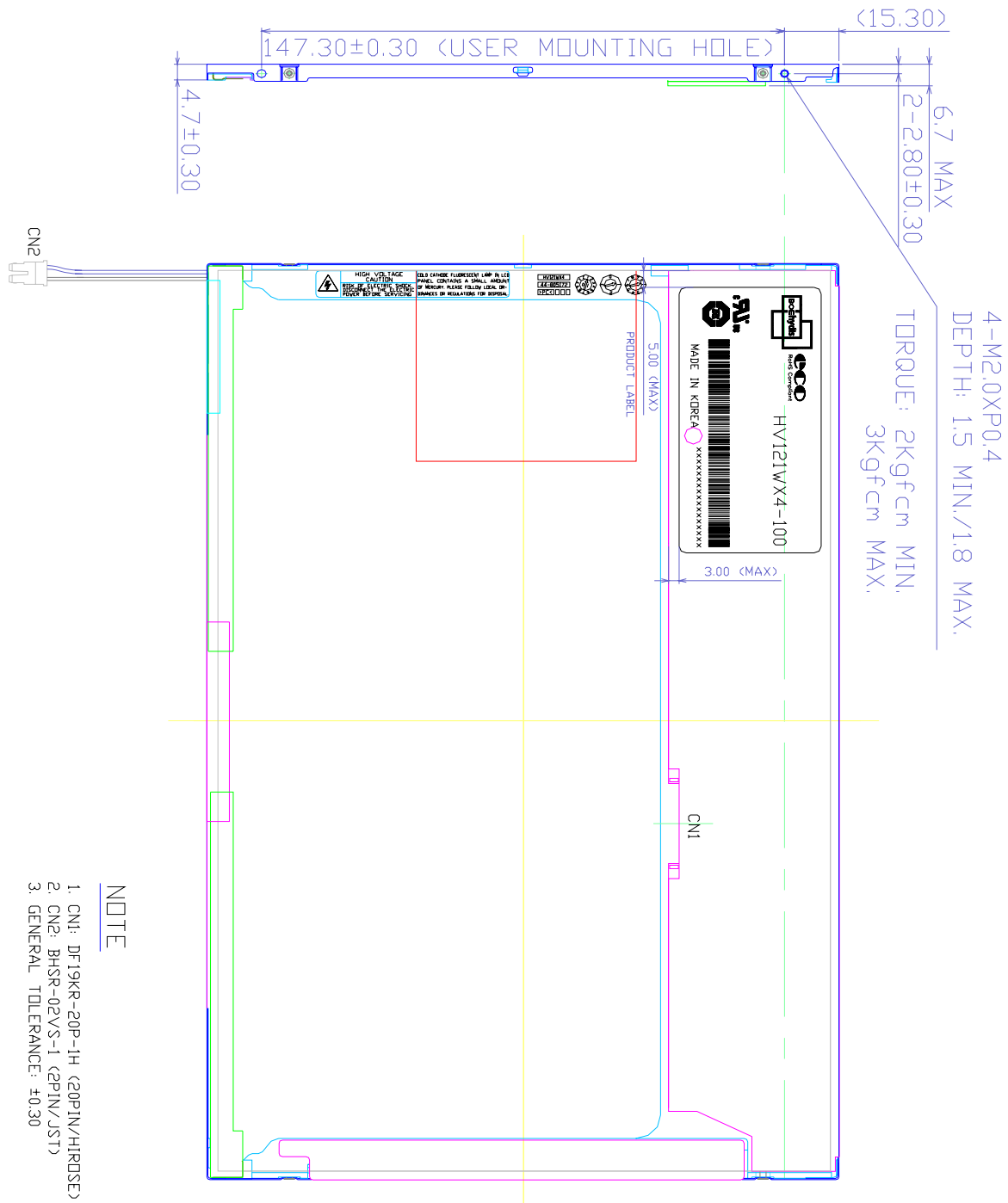
**Figure 6. TFT-LCD Module Outline Dimensions (Rear view)**



# PRODUCT GROUP

REV

ISSUE DATE

TFT-LCD PRODUCT

0

2007.02.15

## 16.0 EDID Data

Address (HEX)	Function	Hex	Dec	Input values	Notes
00	Header	00	0	0	EDID Header
01		FF	255	255	
02		FF	255	255	
03		FF	255	255	
04		FF	255	255	
05		FF	255	255	
06		FF	255	255	
07		00	0	0	
08	ID Manufacturer Name	09	9	BOE	ID = BOE
09		E5	229		
0A	ID Product Code	9A	154	1205	ID = 089A WXGA
0B		08	8		
0C	32-bit serial No.	00	0		
0D		00	0		
0E		00	0		
0F		00	0		
10	Week of manufacture	00	0	0	
11	Year of Manufacture	10	16	2006	Manufactured in 2006
12	EDID Structure Ver.	01	1	1	EDID Ver 1.0
13	EDID revision #	03	3	3	EDID Rev. 0.3
14	Video input definition	80	128	-	
15	Max H image size	1A	26	26	26 cm (Approx)
16	Max V image size	10	16	16	16 cm (Approx)
17	Display Gamma	78	120	2.2	Gamma curve = 2.2
18	Feature support	0A	10		RGB display, Preferred Timming mode
19	Red/Green low bits	86	134	-	Red / Green Low Bits
1A	Blue/White low bits	85	133	-	Blue / White Low Bits
1B	Red x high bits	95	149	0.584	Red (x)
1C	Red y high bits	57	87	0.340	Red (y)
1D	Green x high bits	4D	77	0.302	Green (x)
1E	Green y high bits	8D	141	0.553	Green (y)
1F	Blue x high bits	25	37	0.146	Blue (x)
20	Blue y high bits	24	36	0.141	Blue (y)
21	White x high bits	50	80	0.313	White (x)
22	White y high bits	54	84	0.329	White (y)

SPEC. NUMBER  
S864-1326

SPEC. TITLE  
HV121WX4-100 Product Specification

PAGE  
27 OF 30



# PRODUCT GROUP

REV

ISSUE DATE

TFT-LCD PRODUCT

0

2007.02.15

## 16.0 EDID Data

Address (HEX)	Function	Hex	Dec	Input values	Notes
23	Established timing 1	00	0	-	
24	Established timing 2	00	0	-	
25	Established timing 3	00	0	-	
26	Standard timing #1	01	1		Not Used
27		01	1		
28	Standard timing #2	01	1		Not Used
29		01	1		
2A	Standard timing #3	01	1		Not Used
2B		01	1		
2C	Standard timing #4	01	1		Not Used
2D		01	1		
2E	Standard timing #5	01	1		Not Used
2F		01	1		
30	Standard timing #6	01	1		Not Used
31		01	1		
32	Standard timing #7	01	1		Not Used
33		01	1		
34	Standard timing #8	01	1		Not Used
35		01	1		
36	Detailed timing/monitor descriptor #1	C6	198	71.1	71.1MHz Main clock
37		1B	27		
38		00	0	1280	Hor Active = 1280
39		A0	160	160	Hor Blanking = 160
3A		50	80	-	4 bits of Hor. Active + 4 bits of Hor. Blanking
3B		20	32	800	Ver Active = 800
3C		17	23	23	Ver Blanking = 23
3D		30	48	-	4 bits of Ver. Active + 4 bits of Ver. Blanking
3E		30	48	48	Hor Sync Offset = 48
3F		20	32	32	H Sync Pulse Width = 32
40		36	54	3	V sync Offset = 3 line
41		00	0	6	V Sync Pulse width : 6 line
42		05	5	261	Horizontal Image Size = 261 mm (Low 8 bits)
43		A3	163	163	Vertical Image Size = 163 mm (Low 8 bits)
44		10	16	-	4 bits of Hor Image Size + 4 bits of Ver Image Size
45		00	0	0	Hor Border (pixels)
46		00	0	0	Vertical Border (Lines)
47	19	25	-		

SPEC. NUMBER  
S864-1326

SPEC. TITLE  
HV121WX4-100 Product Specification

PAGE  
28 OF 30



**PRODUCT GROUP**

REV

ISSUE DATE

TFT-LCD PRODUCT

0

2007.02.15

**16.0 EDID Data**

Address (HEX)	Function	Hex	Dec	Input values	Notes
48	Detailed timing/monitor descriptor #2	00	0		
49		00	0		
4A		00	0		
4B		FE	254		
4C		00	0		
4D		0A	10		
4E		20	32		
4F		20	32		
50		20	32		
51		20	32		
52		20	32		
53		20	32		
54		20	32		
55		20	32		
56		20	32		
57		20	32		
58	20	32			
59	20	32			
5A	Detailed timing/monitor descriptor #3	00	0		
5B		00	0		
5C		00	0		
5D		FE	254		
5E		00	0		
5F		42	66	B	
60		4F	79	O	
61		45	69	E	
62		20	32		
63		48	72	H	
64		59	89	Y	
65		44	68	D	
66		49	73	I	
67		53	83	S	
68		0A	10		
69		20	32		
6A	20	32			
6B	20	32			

SPEC. NUMBER  
S864-1326

SPEC. TITLE  
HV121WX4-100 Product Specification

PAGE  
29 OF 30



**PRODUCT GROUP**

REV

ISSUE DATE

TFT-LCD PRODUCT

0

2007.02.15

**16.0 EDID Data**

Address (HEX)	Function	Hex	Dec	Input values	Notes
6C	Detailed timing/monitor descriptor #4	00	0		Product Name Tag (ASCII)
6D		00	0		
6E		00	0		
6F		FE	254		
70		00	0		Model name : HV121WX4-100
71		48	72	H	
72		56	86	V	
73		31	49	1	
74		32	50	2	
75		31	49	1	
76	57	87	W		
77	58	88	X		
78	34	52	4		
79	2D	45	-		
7A	31	49	1		
7B	30	48	0		
7C	30	48	0		
7D	0A	10			
7E	Extension flag	00	0		
7F	Checksum	97	151	-	

SPEC. NUMBER  
S864-1326

SPEC. TITLE  
HV121WX4-100 Product Specification

PAGE  
30 OF 30