



**PROPRIETARY NOTE**  
THIS SPECIFICATION IS THE PROPERTY OF BOE TFT-LCD SBU AND SHALL NOT BE REPRODUCED OR COPIED WITHOUT THE WRITTEN PERMISSION OF BOE TFT-LCD SBU AND MUST BE RETURNED TO BOE TFT-LCD SBU UPON ITS REQUEST

**TITLE : HV150UX1-100**  
**Product Specification for Customer**  
**Rev. 0**

**BOE TFT-LCD SBU**  
**BEIJING BOE OPTOELECTRONICS TECHNOLOGY**  
**BOE HYDIS TECHNOLOGY**

SPEC. NUMBER S864-1238	PRODUCT GROUP TFT LCD	REV. 0	ISSUE DATE 2005.08.22	PAGE 1 OF 26
---------------------------	--------------------------	-----------	--------------------------	-----------------

B2005-C001-O (1/3) A4(210 X 297)

 <b>京东方 BOE</b>	<b>PRODUCT GROUP</b>	REV	ISSUE DATE
	TFT LCD PRODUCT	O	2005.08.22

### REVISION HISTORY

REV.	ECN NO.	DESCRIPTION OF CHANGES	DATE	PREPARED
O		Initial release	05.08.22	S.H.YUN

SPEC. NUMBER S864-1238	SPEC TITLE HV150UX1-100 Product Specification for Customer	PAGE 2 OF 26
---------------------------	---	-----------------



京东方  
BOE

## PRODUCT GROUP

REV

ISSUE DATE

TFT LCD PRODUCT

O

2005.08.22

## Contents

No	Item	Page
1.0	General Description	4
2.0	Absolute Maximum ratings	6
3.0	Electrical specifications.	7
4.0	Optical specifications.	9
5.0	Interface Connection	14
6.0	Signal Timing Specification	17
7.0	Signal Timing waveforms	17
8.0	Input Signals, Display Colors & Gray Scale of Colors	19
9.0	Power Sequence	20
10.0	Mechanical Characteristics	21
11.0	Reliability Test	22
12.0	Handling & Cautions.	22
13.0	Label	23
14.0	Packing information	24
	Outline drawing (Front and Rear)	25

SPEC. NUMBER  
S864-1238

SPEC TITLE  
HV150UX1-100 Product Specification for Customer

PAGE  
3 OF 26



<b>PRODUCT GROUP</b>	REV	ISSUE DATE
	TFT LCD PRODUCT	O

## 1.0 GENERAL DESCRIPTION

### 1.1 Introduction

HV150UX1-100 is a color active matrix TFT LCD module using amorphous silicon TFT's (Thin Film Transistors) as an active switching devices. This module has a 15.0 inch diagonally measured active area with UXGA resolutions (1600 horizontal by 1200 vertical pixel array). Each pixel is divided into RED, GREEN, BLUE dots which are arranged in vertical Stripe and this module can display 262,144 colors. The TFT-LCD panel used for this module is a low reflection and higher color type. Therefore, this module is suitable for Notebook PC. The DC/AC inverter for back-light driving is not built in this model.

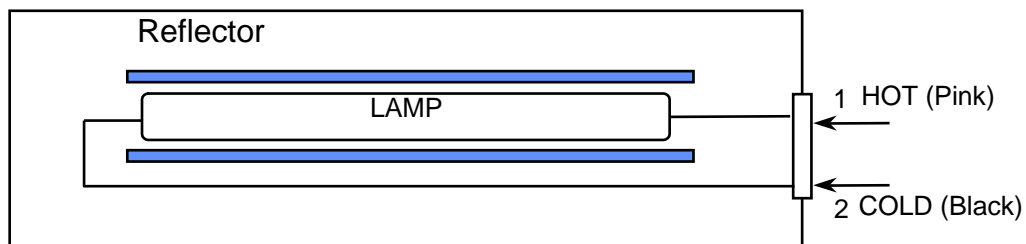
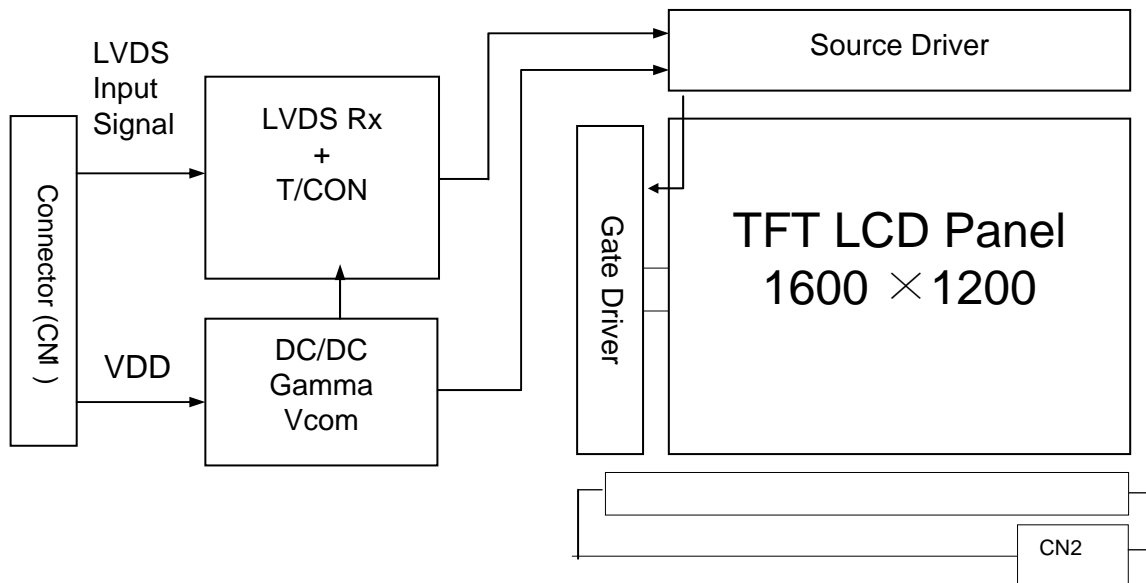

Note) The output of the inverter may change according to the material of the reflector.

SPEC. NUMBER S864-1238	SPEC TITLE HV150UX1-100 Product Specification for Customer	PAGE 4 OF 26
---------------------------	---	-----------------



京东方  
BOE

## PRODUCT GROUP

REV

ISSUE DATE

TFT LCD PRODUCT

O

2005.08.22

### 1.2 Features

- 15.0 UXGA FFS
- Thin and light weight
- 3.3 V power supply
- 2 Channel LVDS Interface
- Single CCFL (Bottom side/Horizontal Direction)
- 262,144 colors
- Data enable signal mode
- Side Mounting Frame
- Green Product (RoHS)
- On Board EDID chip
- High contrast ratio

### 1.3 General Specification

The followings are general specifications at the model HV150UX1-100. (listed in Table 1.)

<Table 1. General Specifications>

Parameter	Specification	Unit	Remarks
Active area	304.5 (H) × 228.4 (V) (15.0" diagonal)	mm	
Number of pixels	1600(H) × 1200(V)	pixels	
Pixel pitch	0.1905(H) × 0.1905(V)	mm	
Pixel arrangement	RGB Vertical stripe		
Display colors	262,144	colors	
Display mode	Normally Black		
Dimensional outline	317.3±0.5(H) × 242.0±0.5(V) × 6.5(D:max)	mm	
Weight	540 g (typ.)	g	
Surface treatment	AG(H45%)/AR/2H		
Back-light	Bottom edge side, 1-CCFL type		Note 1
Power consumption	P <sub>D</sub> : 2.0	W	
	P <sub>BL</sub> : 4.1	W	
	P <sub>total</sub> : 6.1	W	

Note 1: CCFL (Cold Cathode Fluorescent Lamp)

SPEC. NUMBER  
S864-1238

SPEC TITLE  
HV150UX1-100 Product Specification for Customer

PAGE  
5 OF 26



京东方  
BOE

## PRODUCT GROUP

REV

ISSUE DATE

TFT LCD PRODUCT

O

2005.08.22

## 2.0 ABSOLUTE MAXIMUM RATINGS

The followings are maximum values which, if exceeded, may cause faulty operation or damage to the unit. The operational and non-operational maximum voltage and current values are listed in Table 2.

< Table 2. Absolute Maximum Ratings >

$T_a=25+/-2^{\circ}\text{C}$

Parameter	Symbol	Min.	Max.	Unit	Remarks
Power Supply Voltage	$V_{DD}$	-0.3	4.0	V	
Logic Supply Voltage	$V_{IN}$	-0.3	$V_{DD}+0.3$	V	
Lamp Current	$I_L$	3.0	7.0	mArms	(1)
Lamp frequency	$F_L$	45	80	kHz	(1)
Operating Temperature	$T_{OP}$	0	+50	$^{\circ}\text{C}$	(2)
Storage Temperature	$T_{SP}$	-20	+70	$^{\circ}\text{C}$	(2)

Note (1) Permanent damage to the device may occur if maximum values are exceeded. Functional operation should be restricted to the condition described under normal operating conditions.

Note (2) Temperature and relative humidity range are shown in the figure below.

95 % RH Max. ( $40^{\circ}\text{C} \geq T_a$ )

Maximum wet - bulb temperature at  $39^{\circ}\text{C}$  or less. ( $T_a > 40^{\circ}\text{C}$ ) No condensation.

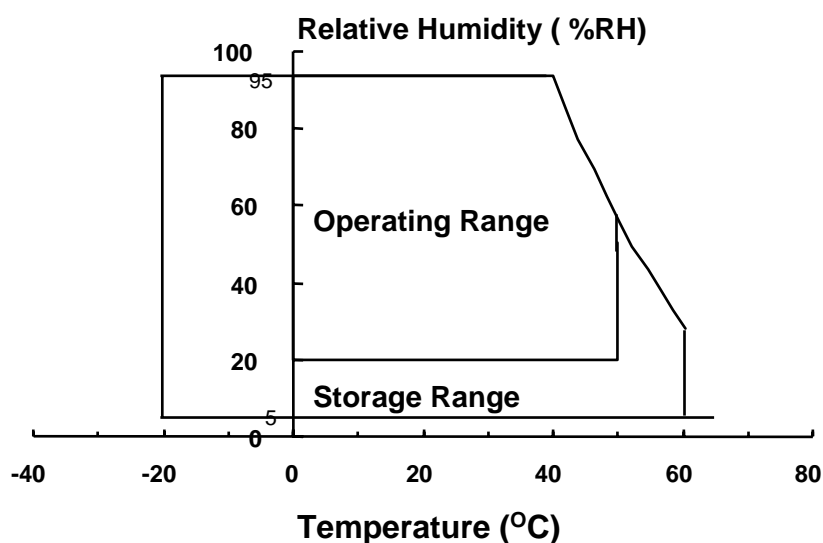

SPEC. NUMBER  
S864-1238

SPEC TITLE  
HV150UX1-100 Product Specification for Customer

PAGE  
6 OF 26



京东方  
BOE

## PRODUCT GROUP

REV

ISSUE DATE

TFT LCD PRODUCT

O

2005.08.22

### 3.0 ELECTRICAL SPECIFICATIONS

#### 3.1 Electrical Specifications

< Table 3. Electrical specifications >

Parameter		Min.	Typ.	Max.	Unit	Remarks	
Power Supply Voltage	$V_{DD}$	3.0	3.3	3.6	V	Note1	
Permissible Input Ripple Voltage	$V_{RF}$	-	-	100	mV	At $V_{DD} = 3.3V$	
Power Supply Current	$I_{DD}$	-	610	-	mA	Note1	
High Level Differential Input Signal Voltage	$V_{IH}$	-	-	100	mV		
Low Level Differential Input Signal Voltage	$V_{IL}$	-	-	100	mV		
Back-light Lamp Voltage	$V_{BL}$	600	630	770	$V_{rms}$	Note2	
Back-light Lamp Current	$I_{BL}$	3.0	6.5	7.0	mA		
Back-light Lamp operating Frequency	$F_L$	45	60	80	KHz	One Lamp , Note3	
Lamp Start Voltage		1,180	940	-	$V_{rms}$	At $T_a = 25^{\circ}C$ Note 4	
		1,420	1,180	-	$V_{rms}$	At $T_a = 0^{\circ}C$ Note 4	
Lamp Life		12,000	15,000	-	Hrs	At $I_{BL} = 6.5 mA$ , Max. Note5	
Power Consumption		$P_D$	-	2.0	-	W	Note1
		$P_{BL}$	-	4.1	4.5	W	Note6, $I_{BL} = 6.5mA$
		$P_{total}$	-	6.1	-	W	

SPEC. NUMBER  
S864-1238

SPEC TITLE  
HV150UX1-100 Product Specification for Customer

PAGE  
7 OF 26

 <b>京东方 BOE</b>	<b>PRODUCT GROUP</b>	REV	ISSUE DATE
	TFT LCD PRODUCT	O	2005.08.22

- Notes :
1. The supply voltage is measured and specified at the interface connector of LCM.  
The current draw and power consumption specified is for 3.3V at 25℃.
    - a) Typ : Window XP pattern
    - b) Max : Vertical sub line pattern (L255)
  2. Reference value, which is measured with Samsung Electric SIC-180 Inverter.  
(VBL Min is value at IBL Min and VBL Max is value at IBL Max)
  3. The lamp frequency should be selected as different as possible from the horizontal synchronous frequency and its harmonics to avoid interference which may cause line flow on the display.
  4. For starting the backlight unit, the output voltage of DC/AC's transformer should be larger than the minimum lamp starting voltage.  
(1,180 Vrms at 25 ℃ & 1,420 Vrms at 0 ℃)  
If an inverter has shutdown function it should keep its output for more than 1 second even if the lamp connector open. Otherwise the lamps may not to be turned on.
  5. End of Life shall be determined by the time when any of the following is satisfied under continuous lighting at 25℃ and IBL = 6.5[mA] Max Only.
    - Intensity drops to 50% of the Initial Value.
  6. Calculated value for reference (VBL × IBL)

SPEC. NUMBER S864-1238	SPEC TITLE HV150UX1-100 Product Specification for Customer	PAGE 8 OF 26
---------------------------	---	-----------------





京东方  
BOE

## PRODUCT GROUP

REV

ISSUE DATE

TFT LCD PRODUCT

O

2005.08.22

### 4.0 OPTICAL SPECIFICATION

#### 4.1 Overview

The test of Optical specifications shall be measured in a dark room (ambient luminance  $\leq 1$  lux and temperature =  $25 \pm 2^\circ\text{C}$ ) with the equipment of Luminance meter system (Goniometer system and TOPCONE BM-5) and test unit shall be located at an approximate distance 50cm from the LCD surface at a viewing angle of  $\Theta$  and  $\Phi$  equal to  $0^\circ$ . We refer to  $\Theta\emptyset=0$  ( $=\Theta 3$ ) as the 3 o'clock direction (the "right"),  $\Theta\emptyset=90$  ( $=\Theta 12$ ) as the 12 o'clock direction ("upward"),  $\Theta\emptyset=180$  ( $=\Theta 9$ ) as the 9 o'clock direction ("left") and  $\Theta\emptyset=270$  ( $=\Theta 6$ ) as the 6 o'clock direction ("bottom"). While scanning  $\Theta$  and/or  $\emptyset$ , the center of the measuring spot on the Display surface shall stay fixed. The backlight should be operating for 30 minutes prior to measurement... VDD shall be  $3.3 \pm 0.3\text{V}$  at  $25^\circ\text{C}$ . Optimum viewing angle direction is 6 o'clock.

#### 4.2 Optical Specifications

<Table 4. Optical Specifications>

Parameter		Symbol	Condition	Min.	Typ.	Max.	Unit	Remark			
Viewing Angle range	Horizontal	$\Theta_3$	CR > 10	-	85	-	Deg.	Note 1			
		$\Theta_9$		-	85	-	Deg.				
	Vertical	$\Theta_{12}$		-	85	-	Deg.				
		$\Theta_6$		-	85	-	Deg.				
Luminance Contrast ratio		CR	$\Theta = 0^\circ$	-	500:1	-		Note 2			
Center Luminance of White	1 Point	$Y_w$	$\Theta = 0^\circ$ IBL = 6mA	170	200	-	cd/m <sup>2</sup>				
White Luminance uniformity	5 Points	$\Delta Y5$		80	85	-	%				
White Chromaticity		$W_x$	$\Theta = 0^\circ$	0.273	0.303	0.333		Note 3			
		$W_y$		0.299	0.329	0.359					
Reproduction of color	Red	$R_x$		0.544	0.574	0.604					
		$R_y$		0.306	0.336	0.366					
	Green	$G_x$		0.268	0.298	0.328					
		$G_y$		0.523	0.553	0.583					
	Blue	$B_x$		0.119	0.149	0.179					
		$B_y$		0.109	0.139	0.169					
Response Time	Rise	$T_r$		Ta= $25^\circ\text{C}$ $\Theta = 0^\circ$	-	30			-	ms	
	Decay	$T_d$			-	30			-		
Cross Talk		CT	$\Theta = 0^\circ$	-	-	2.0	%				

SPEC. NUMBER  
S864-1238

SPEC TITLE  
HV150UX1-100 Product Specification for Customer

PAGE  
9 OF 26

 <b>京东方 BOE</b>	<b>PRODUCT GROUP</b>	REV	ISSUE DATE
	TFT LCD PRODUCT	O	2005.08.22

- Notes :
- Viewing angle is the angle at which the contrast ratio is greater than 10. The viewing angles are determined for the horizontal or 3, 9 o'clock direction and the vertical or 6, 12 o'clock direction with respect to the optical axis which is normal to the LCD surface (see FIGURE1 shown in Appendix).
  - Contrast measurements shall be made at viewing angle of  $\theta = 0$  and at the center of the LCD surface. Luminance shall be measured with all pixels in the view field set first to white, then to the dark (black) state .  
(see FIGURE1 shown in Appendix) Luminance Contrast Ratio (CR) is defined mathematically as  $CR = \text{Luminance when displaying a white raster} / \text{Luminance when displaying a black raster}$ .
  - The color chromaticity coordinates specified in Table 4. shall be calculated from the spectral data measured with all pixels first in red, green, blue, and white. Measurements shall be made at the center of the panel.

SPEC. NUMBER S864-1238	SPEC TITLE HV150UX1-100 Product Specification for Customer	PAGE 10 OF 26
---------------------------	---	------------------



**PRODUCT GROUP**

REV

ISSUE DATE

TFT LCD PRODUCT

O

2005.08.22

**4.3 Optical measurements**

**Figure 1. Measurement Set Up**

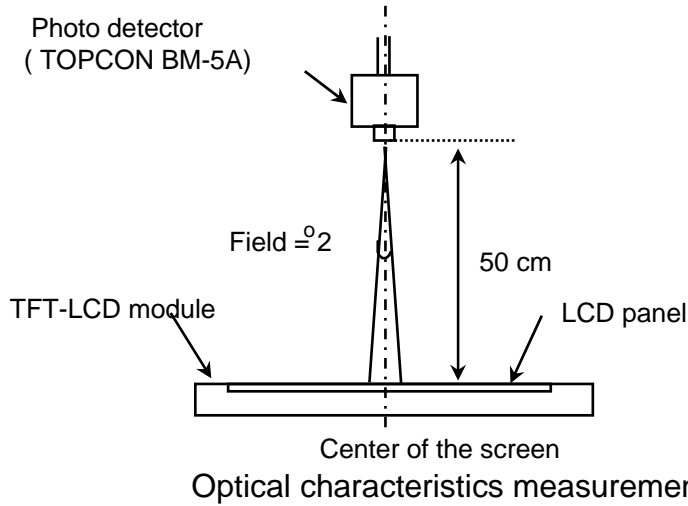

**Figure 2. White Luminance and Uniformity Measurement Locations (5 points)**

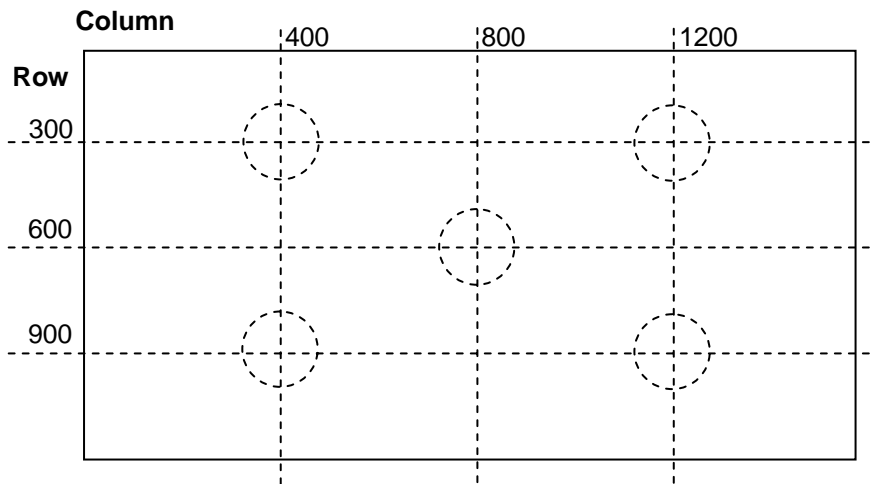

Center Luminance of white is defined as luminance values of center 1 point and 5 points across the LCD surface. Luminance shall be measured with all pixels in the view field set first to white. This measurement shall be taken at the locations shown in FIGURE 2 for a total of the measurements per display.

SPEC. NUMBER  
S864-1238

SPEC TITLE  
HV150UX1-100 Product Specification for Customer

PAGE  
11 OF 26



**PRODUCT GROUP**

REV

ISSUE DATE

TFT LCD PRODUCT

O

2005.08.22

**Figure 3. Response Time Testing**

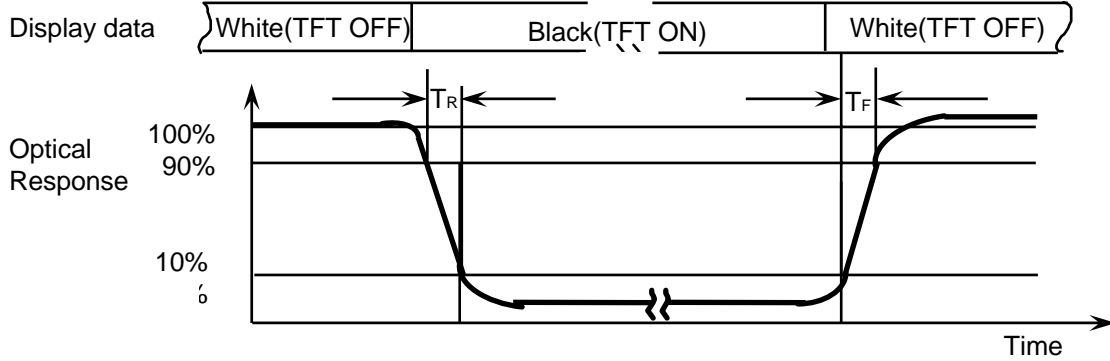

The electro-optical response time measurements shall be made as shown in FIGURE 3 (shown in Appendix) by switching the “data” input signal ON and OFF. The times needed for the luminance to change from 10% to 90% is Td and 90% to 10% is Tr.

**Figure 4. Cross Modulation Test Description**

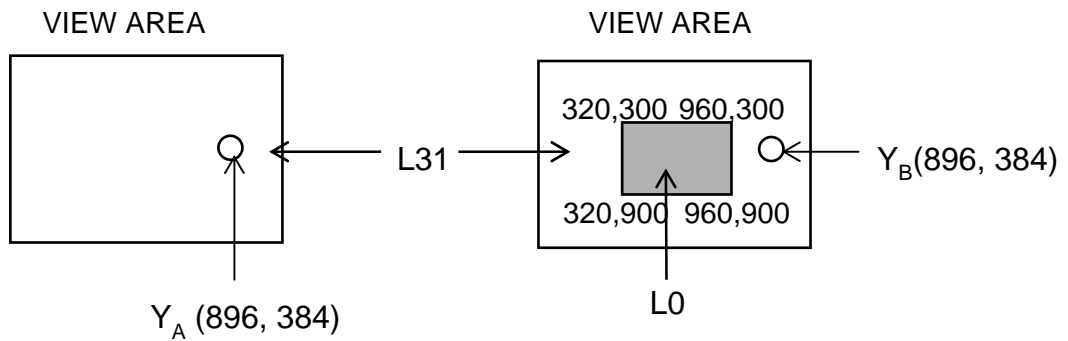

$$\text{Cross-Talk (\%)} = \left| \frac{Y_B - Y_A}{Y_B} \right| \times 100$$

Where:

Y<sub>A</sub> = Initial luminance of measured area (cd/m<sup>2</sup>)

Y<sub>B</sub> = Subsequent luminance of measured area (cd/m<sup>2</sup>)

The location measured will be exactly the same in both patterns

Cross-Talk of one area of the LCD surface by another shall be measured by comparing the luminance (YA) of a 25mm diameter area, with all display pixels set to a gray level, to the luminance (YB) of that same area when any adjacent area is driven dark (Refer to FIGURE 4).

SPEC. NUMBER  
S864-1238

SPEC TITLE  
HV150UX1-100 Product Specification for Customer

PAGE  
12 OF 26



京东方  
BOE

## PRODUCT GROUP

REV

ISSUE DATE

TFT LCD PRODUCT

O

2005.08.22

### 5.0 INTERFACE CONNECTION.

#### 5.1 Electrical Interface Connection

The electronics interface connector is a model FI-XB30S-HFxx manufactured by JAE or equivalent. The mating connector part number is FI-S30S or FI-SE30M or FI-S30S or equivalent. The connector interface pin assignments are listed in Table 5.

<Table 5. Pin Assignments for the Interface Connector>

Terminal	Symbol	Functions
1	GND	Low
2	VDD	Power Supply : +3.3V (typical)
3	VDD	Power Supply : +3.3V (typical)
4	V <sub>EDID</sub>	Reserved (for V <sub>EDID</sub> )
5	NC	Reserved (for Supplier test point)
6	CLK <sub>EDID</sub>	Reserved (for CkI <sub>EDID</sub> )
7	DATA <sub>EDID</sub> <sup>-</sup>	Reserved (for DATA <sub>EDID</sub> )
8	O_RIN0-	-LVDS differential data input (R0~R5,G0) (Odd pixel)
9	O_RIN0+	+LVDS differential data input (R0~R5,G0) (Odd pixel)
10	VSS	GND
11	O_RIN1-	-LVDS differential data input (G1~G5,B0,B1) (Odd pixel)
12	O_RIN1+	+LVDS differential data input (G1~G5,B0,B1) (Odd pixel)
13	VSS	GND
14	O_RIN2-	-LVDS differential data input (B2~B5,HS,VS,DE) (Odd pixel)
15	O_RIN2+	+LVDS differential data input (B2~B5,HS,VS,DE) (Odd pixel)
16	VSS	GND
17	O_CLKIN-	-LVDS differential Clock input (Odd pixel)
18	O_CLKIN+	+LVDS differential Clock input (Odd pixel)
19	VSS	GND
20	E_RIN0-	-LVDS differential data input (R0~R5,G0) (Even pixel)
21	E_RIN0+	+LVDS differential data input (R0~R5,G0) (Even pixel)
22	VSS	GND
23	E_RIN1-	-LVDS differential data input (G1~G5,B0,B1) (Even pixel)
24	E_RIN1+	+LVDS differential data input (G1~G5,B0,B1) (Even pixel)
25	VSS	GND
26	E_RIN2-	-LVDS differential data input (B2~B5,HS,VS,DE) (Even pixel)
27	E_RIN2+	+LVDS differential data input (B2~B5,HS,VS,DE) (Even pixel)
28	VSS	GND
29	E_CLKIN-	-LVDS differential Clock input (Even pixel)
30	E_CLKIN+	+LVDS differential Clock input (Even pixel)

SPEC. NUMBER  
S864-1238

SPEC TITLE  
HV150UX1-100 Product Specification for Customer

PAGE  
13 OF 26



**PRODUCT GROUP**

REV

ISSUE DATE

TFT LCD PRODUCT

O

2005.08.22

**5-2. LVDS Interface**

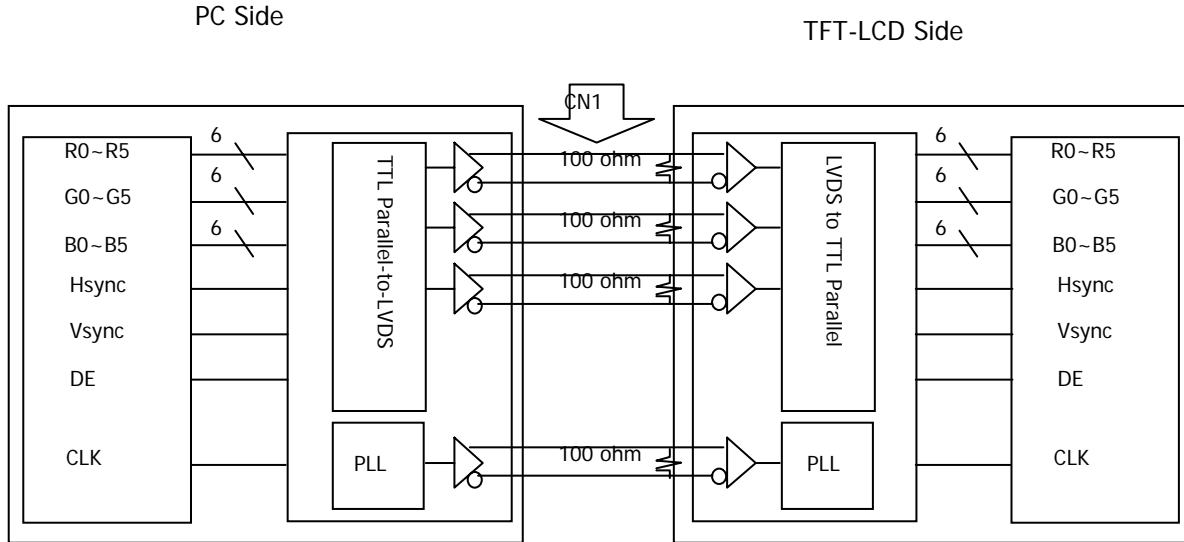

Note. Transmitter : Thine THC63LVDM63A or equivalent. Transmitter is not contained in Module.

**5.3.LVDS Input signal**

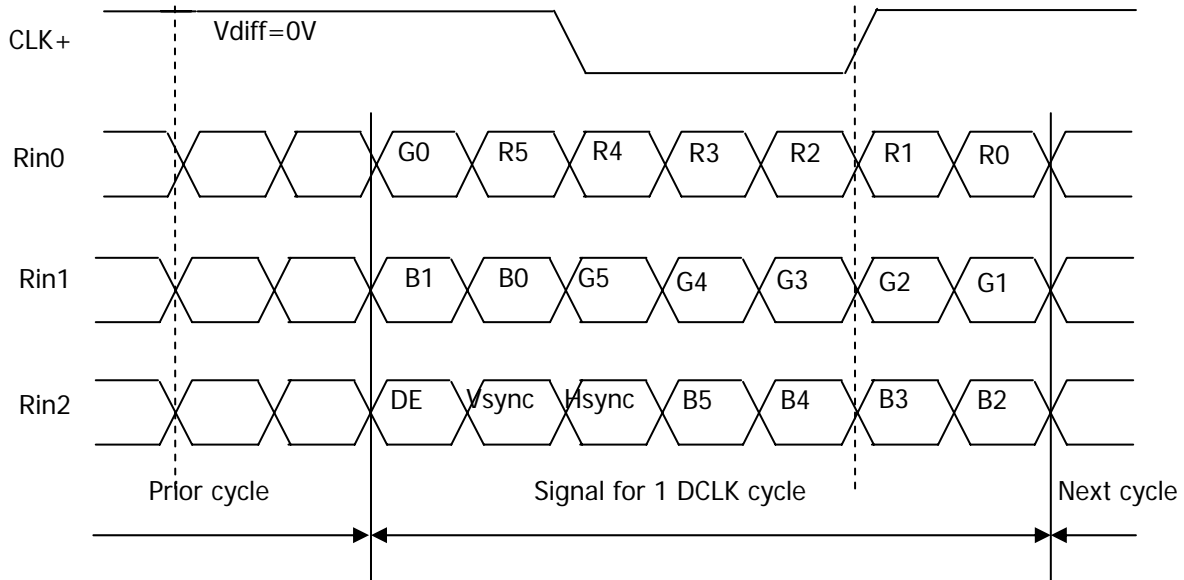

Note. Pin connection in case of using Thine THC63LVDM63A

SPEC. NUMBER S864-1238	SPEC TITLE HV150UX1-100 Product Specification for Customer	PAGE 14 OF 26
---------------------------	---	------------------



京东方  
BOE

## PRODUCT GROUP

REV

ISSUE DATE

TFT LCD PRODUCT

O

2005.08.22

<Table 6. Pin connection in case of using Thine THC63LVDM63A>

Input signal	Transmitter	Input signal	Transmitter
DCLK	CLK IN(26)	G4	TB3(10)
R0	TA0(44)	G5	TB4(12)
R1	TA1(45)	B0	TB5(13)
R2	TA2(47)	B1	TB6(15)
R3	TA3(48)	B2	TC0(16)
R4	TA4(1)	B3	TC1(18)
R5	TA5(3)	B4	TC2(19)
G0	TA6(4)	B5	TC3(20)
G1	TB0(6)	Hsync	TC4(22)
G2	TB1(7)	Vsync	TC5(23)
G3	TB2(9)	DE	TC6(25)

### 5.4.Back-light Interface

The Back-light interface connector is a model BHSR-02VS-1 manufactured by JST or equivalent. The connector interface pin assignments are listed in Table 7.

<Table 7. Back-light Electrical Interface>

Terminal No.	Symbol	Function	Color
1	VL	CCFL Power Supply (High Voltage)	Pink
2	GL	CCFL Power Supply (GND Side)	Black

SPEC. NUMBER  
S864-1238

SPEC TITLE  
HV150UX1-100 Product Specification for Customer

PAGE  
15 OF 26



京东方  
BOE

**PRODUCT GROUP**

TFT LCD PRODUCT

REV

O

ISSUE DATE

2005.08.22

**6.0. SIGNAL TIMING SPECIFICATION**

The specification of the signal timing parameters are listed in Table 8.

<Table 8. Signal Timing Specification.>

Item	Symbols	Min	Typ	Max	Unit
Frame Period	T1	28.57	16.67	15.87	ms
Vertical Display Period	T2	-	16	-	ms
One line Scanning Period	T3	-	13.3	-	us
Horizontal Display Period	T4	-	9.9	-	us
Clock Frequency	1/T5	47.25	81	85	MHz

**7.0 SIGNAL TIMING WAVEFORMS**

**7.1 Timing wave forms of interface signal**

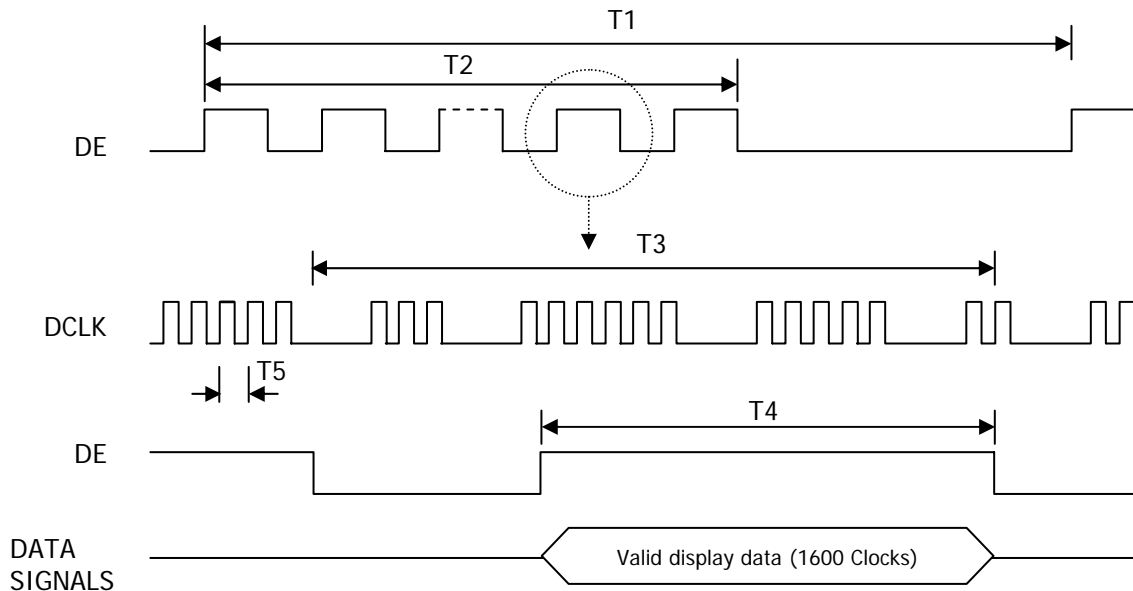

SPEC. NUMBER  
S864-1238

SPEC TITLE  
HV150UX1-100 Product Specification for Customer

PAGE  
16 OF 26





京东方  
BOE

**PRODUCT GROUP**

TFT LCD PRODUCT

REV

O

ISSUE DATE

2005.08.22

**7.2 LVDS Rx Interface Timing Parameter**

The specification of the LVDS Rx interface timing parameter is listed in Table 9.

<Table 9. LVDS Rx Interface Timing Specification>

Item	Symbol	Min	Typ	Max	Unit	Remark
PLL Set	tRPLL	-	-	10.0	msec	
CLKIN Period	tRCIP	11.77	12.35	21.16	nsec	
Input Data 0	tRIP0	-0.4	0.0	+0.4	nsec	
Input Data 1	tRIP1	tRCIP/7-0.4	tRCIP/7	tRCIP/7+0.4	nsec	
Input Data 2	tRIP2	2 × tRCIP/7-0.4	2 × tRCIP/7	2 × tRCIP/7+0.4	nsec	
Input Data 3	tRIP3	3 × tRCIP/7-0.4	3 × tRCIP/7	3 × tRCIP/7+0.4	nsec	
Input Data 4	tRIP4	4 × tRCIP/7-0.4	4 × tRCIP/7	4 × tRCIP/7+0.4	nsec	
Input Data 5	tRIP5	5 × tRCIP/7-0.4	5 × tRCIP/7	5 × tRCIP/7+0.4	nsec	
Input Data 6	tRIP6	6 × tRCIP/7-0.4	6 × tRCIP/7	6 × tRCIP/7+0.4	nsec	

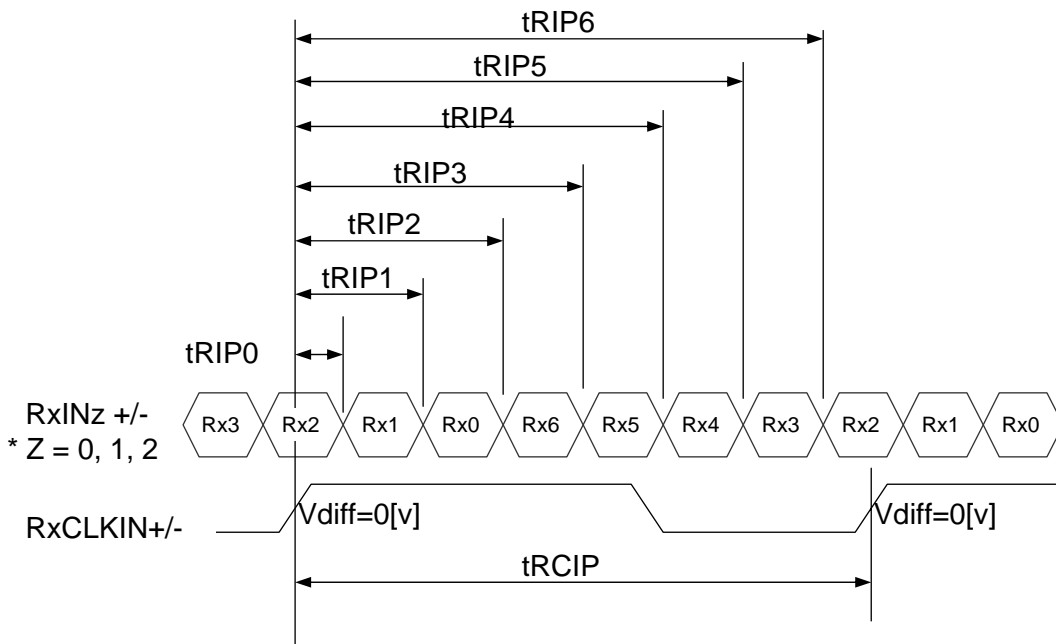

SPEC. NUMBER  
S864-1238

SPEC TITLE  
HV150UX1-100 Product Specification for Customer

PAGE  
17 OF 26



京东方  
BOE

**PRODUCT GROUP**

REV

ISSUE DATE

TFT LCD PRODUCT

O

2005.08.22

**8.0 INPUT SIGNALS, BASIC DISPLAY COLORS & GRAY SCALE OF COLORS**

Each color is displayed in sixty-four gray scales from a 6 bit data signal input. A total of 262,144 colors are derived from the resultant 18 bit data. Table 10. shows the input signals, basic display colors and gray scale for each color.

<Table 10. Input signals, Basic display colors and Gray scale for each color.>

	Colors & Gray scale	Data signal																	
		R0	R1	R2	R3	R4	R5	G0	G1	G2	G3	G4	G5	B0	B1	B2	B3	B4	B5
Basic colors	Black	0	0	0	0	0	0	0	0	0	0	0	0	0	0	0	0	0	0
	Blue	0	0	0	0	0	0	0	0	0	0	0	0	1	1	1	1	1	1
	Green	0	0	0	0	0	0	1	1	1	1	1	1	0	0	0	0	0	0
	Light Blue	0	0	0	0	0	0	1	1	1	1	1	1	1	1	1	1	1	1
	Red	1	1	1	1	1	1	0	0	0	0	0	0	0	0	0	0	0	0
	Purple	1	1	1	1	1	1	0	0	0	0	0	0	1	1	1	1	1	1
	Yellow	1	1	1	1	1	1	1	1	1	1	1	1	0	0	0	0	0	0
White	1	1	1	1	1	1	1	1	1	1	1	1	1	1	1	1	1	1	
Gray scale of Red	Black	0	0	0	0	0	0	0	0	0	0	0	0	0	0	0	0	0	0
	△	1	0	0	0	0	0	0	0	0	0	0	0	0	0	0	0	0	0
	Darker	0	1	0	0	0	0	0	0	0	0	0	0	0	0	0	0	0	0
	△																		
	▽																		
	Brighter	1	0	1	1	1	1	0	0	0	0	0	0	0	0	0	0	0	0
▽	0	1	1	1	1	1	0	0	0	0	0	0	0	0	0	0	0	0	
Red	1	1	1	1	1	1	0	0	0	0	0	0	0	0	0	0	0	0	
Gray scale of Green	Black	0	0	0	0	0	0	0	0	0	0	0	0	0	0	0	0	0	0
	△	0	0	0	0	0	0	1	0	0	0	0	0	0	0	0	0	0	0
	Darker	0	0	0	0	0	0	0	1	0	0	0	0	0	0	0	0	0	0
	△																		
	▽																		
	Brighter	0	0	0	0	0	0	1	0	1	1	1	1	0	0	0	0	0	0
▽	0	0	0	0	0	0	0	1	1	1	1	1	0	0	0	0	0	0	
Green	0	0	0	0	0	0	1	1	1	1	1	1	0	0	0	0	0	0	
Gray scale of Blue	Black	0	0	0	0	0	0	0	0	0	0	0	0	0	0	0	0	0	0
	△	0	0	0	0	0	0	0	0	0	0	0	0	1	0	0	0	0	0
	Darker	0	0	0	0	0	0	0	0	0	0	0	0	0	1	0	0	0	0
	△																		
	▽																		
	Brighter	0	0	0	0	0	0	0	0	0	0	0	0	1	0	1	1	1	1
▽	0	0	0	0	0	0	0	0	0	0	0	0	0	1	1	1	1	1	
Blue	0	0	0	0	0	0	0	0	0	0	0	0	1	1	1	1	1	1	
Gray scale of White & Black	Black	0	0	0	0	0	0	0	0	0	0	0	0	0	0	0	0	0	0
	△	1	0	0	0	0	0	1	0	0	0	0	0	1	0	0	0	0	0
	Darker	0	1	0	0	0	0	0	1	0	0	0	0	0	1	0	0	0	0
	△																		
	▽																		
	Brighter	1	0	1	1	1	1	1	0	1	1	1	1	1	0	1	1	1	1
▽	0	1	1	1	1	1	0	1	1	1	1	1	0	1	1	1	1	1	
White	1	1	1	1	1	1	1	1	1	1	1	1	1	1	1	1	1	1	

SPEC. NUMBER  
S864-1238

SPEC TITLE  
HV150UX1-100 Product Specification for Customer

PAGE  
18 OF 26



京东方  
BOE

## PRODUCT GROUP

TFT LCD PRODUCT

REV

O

ISSUE DATE

2005.08.22

### 9.0 POWER SEQUENCE

To prevent a latch-up or DC operation of the LCD module, the power on/off sequence shall be as shown in below

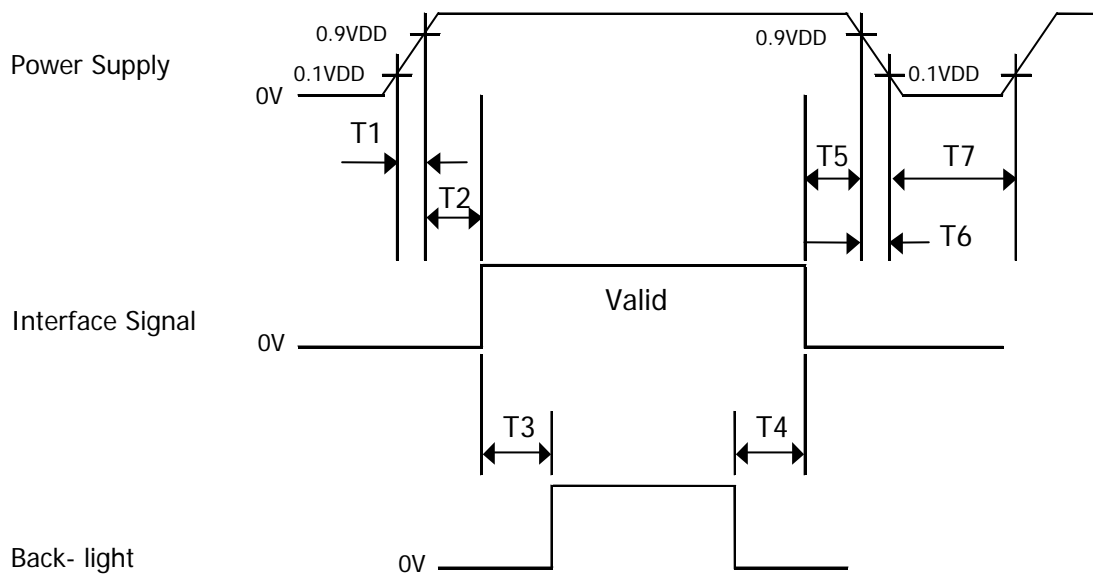

- $T1 \leq 10 \text{ ms}$
- $0 \leq T2 \leq 50 \text{ ms}$
- $200\text{ms} \leq T3$
- $0 \leq T4$
- $0 \leq T5$
- $0 \leq T6 \leq 10\text{ms}$
- $150\text{ms} \leq T7$

Notes : 1. When the power supply VDD is 0V, Keep the level of input signals on the low or keep high impedance.

2. Do not keep the interface signal high impedance when power is on.

Back Light must be turn on after power for logic and interface signal are valid.

SPEC. NUMBER  
S864-1238

SPEC TITLE  
HV150UX1-100 Product Specification for Customer

PAGE  
19 OF 26



京东方  
BOE

## PRODUCT GROUP

REV

ISSUE DATE

TFT LCD PRODUCT

O

2005.08.22

### 10.0 MECHANICAL CHARACTERISTICS

#### 10.1 Dimensional Requirements

FIGURE 6 (located in Appendix) shows mechanical outlines for the model HV150UX1-100. Other parameters are shown in Table 11.

<Table 11. Dimensional Parameters>

Parameter	Specification	Unit
Dimensional outline	$317.3 \pm 0.5 \times 242.0 \pm 0.5 \times 6.5$ max	mm
Weight	540g (typ.)	gram
Back-light	Connector : BHSR-02VS-1	
	CCFL, Horizontal-lamp type	
	Length : $40.0 \pm 5.0$	mm

#### 10.2 Mounting

See FIGURE 6. (shown in Appendix)

#### 10.3 Anti-Glare and Polarizer Hardness.

The surface of the LCD has an anti-glare coating to minimize reflection and a coating to reduce scratching.

#### 10.4 Light Leakage

There shall not be visible light from the back-lighting system around the edges of the screen as seen from a distance 50cm from the screen with an overhead light level of 350lux.

SPEC. NUMBER  
S864-1238

SPEC TITLE  
HV150UX1-100 Product Specification for Customer

PAGE  
20 OF 26



京东方  
BOE

## PRODUCT GROUP

REV

ISSUE DATE

TFT LCD PRODUCT

O

2005.08.22

### 11.0 RELIABILITY TEST

The Reliability test items and its conditions are shown in below.

<Table 12. Reliability test>

No	Test Items	Conditions
1	High temperature storage test	Ta = 60 °C, 240 hrs
2	Low temperature storage test	Ta = -20 °C, 240 hrs
3	High temperature & high humidity operation test	Ta = 50 °C, 80%RH, 240hrs
4	High temperature operation test	Ta = 50 °C, 240hrs
5	Low temperature operation test	Ta = 0 °C, 240hrs
6	Thermal shock	Ta = -20 °C ↔ 60 °C (0.5 hr), 100 cycle
7	Vibration test (non-operating)	1.5G,10~300Hz for X,Y,Z axis 30 minutes for each axis
8	Shock test (non-operating)	220G,2msec, half sine (6 times)
9	Electro-static discharge test (non-operating)	Air : 150 pF, 330Ω, 15 KV Contact : 150 pF, 330Ω, 8 KV

### 12.0 HANDLING & CAUTIONS

(1) Cautions when taking out the module

- Pick the pouch only, when taking out module from a shipping package.

(2) Cautions for handling the module

- As the electrostatic discharges may break the LCD module, handle the LCD module with care. Peel a protection sheet off from the LCD panel surface as slowly as possible.
- As the LCD panel and back - light element are made from fragile glass material, impulse and pressure to the LCD module should be avoided.
- As the surface of the polarizer is very soft and easily scratched, use a soft dry cloth without chemicals for cleaning.
- Do not pull the interface connector in or out while the LCD module is operating.
- Put the module display side down on a flat horizontal plane.
- Handle connectors and cables with care.

(3) Cautions for the operation

- When the module is operating, do not lose CLK, ENAB signals. If any one of these signals is lost, the LCD panel would be damaged.
- Obey the supply voltage sequence. If wrong sequence is applied, the module would be damaged.

SPEC. NUMBER  
S864-1238

SPEC TITLE  
HV150UX1-100 Product Specification for Customer

PAGE  
21 OF 26

 京东方 BOE	<b>PRODUCT GROUP</b>	REV	ISSUE DATE
	TFT LCD PRODUCT	O	2005.08.22

- (4) Cautions for the atmosphere
- Dew drop atmosphere should be avoided.
  - Do not store and/or operate the LCD module in a high temperature and/or humidity atmosphere. Storage in an electro-conductive polymer packing pouch and under relatively low temperature atmosphere is recommended.
- (5) Cautions for the module characteristics
- Do not apply fixed pattern data signal to the LCD module at product aging.
  - Applying fixed pattern for a long time may cause image sticking.
- (6) Other cautions
- Do not disassemble and/or re-assemble LCD module.
  - Do not re-adjust variable resistor or switch etc.
  - When returning the module for repair or etc., Please pack the module not to be broken. We recommend to use the original shipping packages.

### 13.0 LABEL

(1) Product label

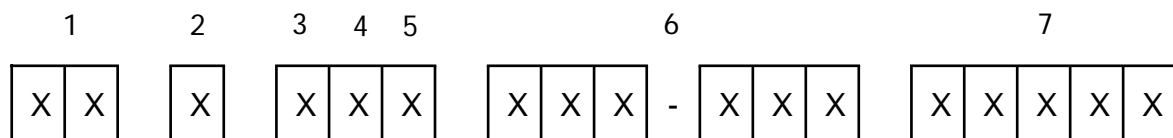

**Type designation**

**No 1. Control Number**

**No 2. Rank / Grade**

**No 3. Company (H:BOE HYDIS, O:BOE OT)**

**No 4. Year (5 : 2005, 6 : 2006, ...)**

**No 5. Month (1, 2, 3, ..., 9, X, Y, Z)**

**No 6. Product Identification**

**No 7. Serial Number**

SPEC. NUMBER S864-1238	SPEC TITLE HV150UX1-100 Product Specification for Customer	PAGE 22 OF 26
---------------------------	---	------------------

	<b>PRODUCT GROUP</b>	REV	ISSUE DATE
	TFT LCD PRODUCT	O	2005.08.22

(2) High voltage caution label

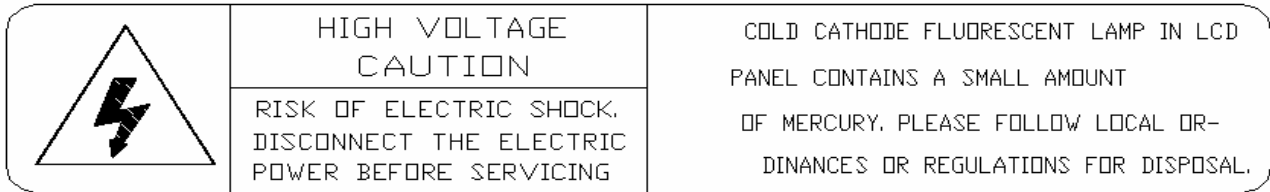

(3) Box label

Label Size: 108 mm (L) × 56 mm (W)

Contents

Model: HV150UX1-100

Q'ty: Module Q'ty in one box

Serial No.: Box Serial No. See next figure for detail description.

Date: Packing Date

FG Code: FG Code of Product

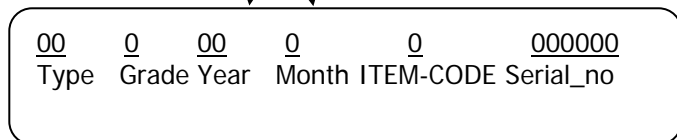
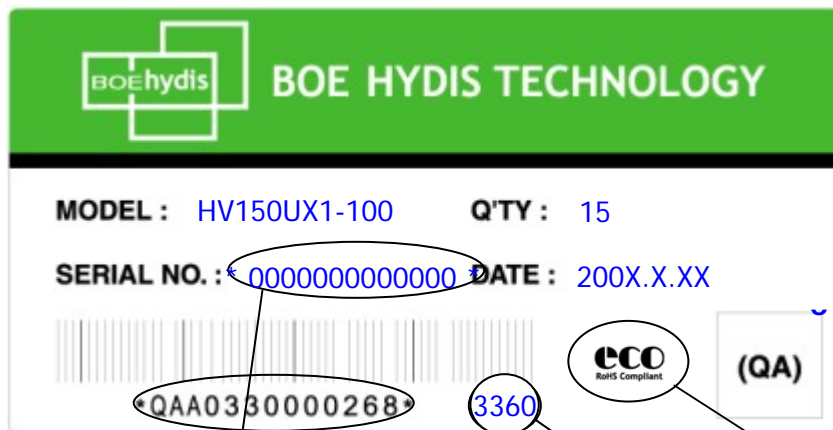

FG CODE

RoHS Mark

SPEC. NUMBER S864-1238	SPEC TITLE HV150UX1-100 Product Specification for Customer	PAGE 23 OF 26
---------------------------	---	------------------



**PRODUCT GROUP**

REV

ISSUE DATE

TFT LCD PRODUCT

O

2005.08.22

**14.0 PACKING INFORMATION**

14.1 Packing order

Put Pad into the box.

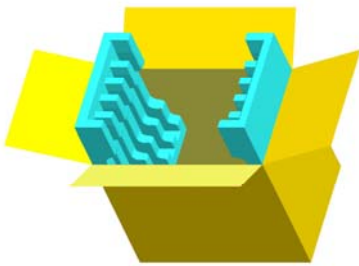

Put silica gels in the box.

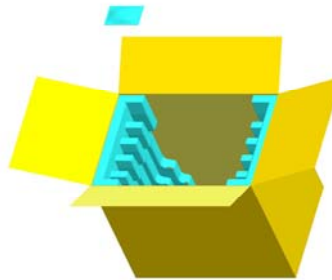

After sealing the box, attach Packing Label on the attach position sign area of the box.



Place a cover on the top of the box.

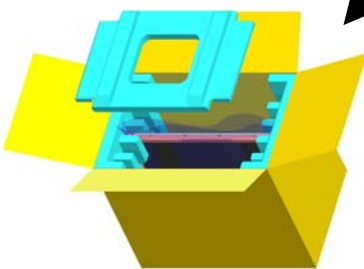

As shown in the figure, place the Modules bundled by shielding bag in the box.

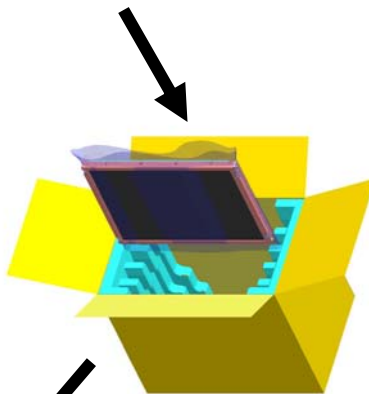

14.2 Notes

- Box Dimension: 333mm(W)X 333mm(D)X 435(H)
- Package Quantity in one Box: 10pcs

SPEC. NUMBER  
S864-1238

SPEC TITLE  
HV150UX1-100 Product Specification for Customer

PAGE  
24 OF 26





**PRODUCT GROUP**

REV

ISSUE DATE

TFT LCD PRODUCT

O

2005.08.22

**Figure 5. TFT-LCD Module Outline Dimension (Front View)**

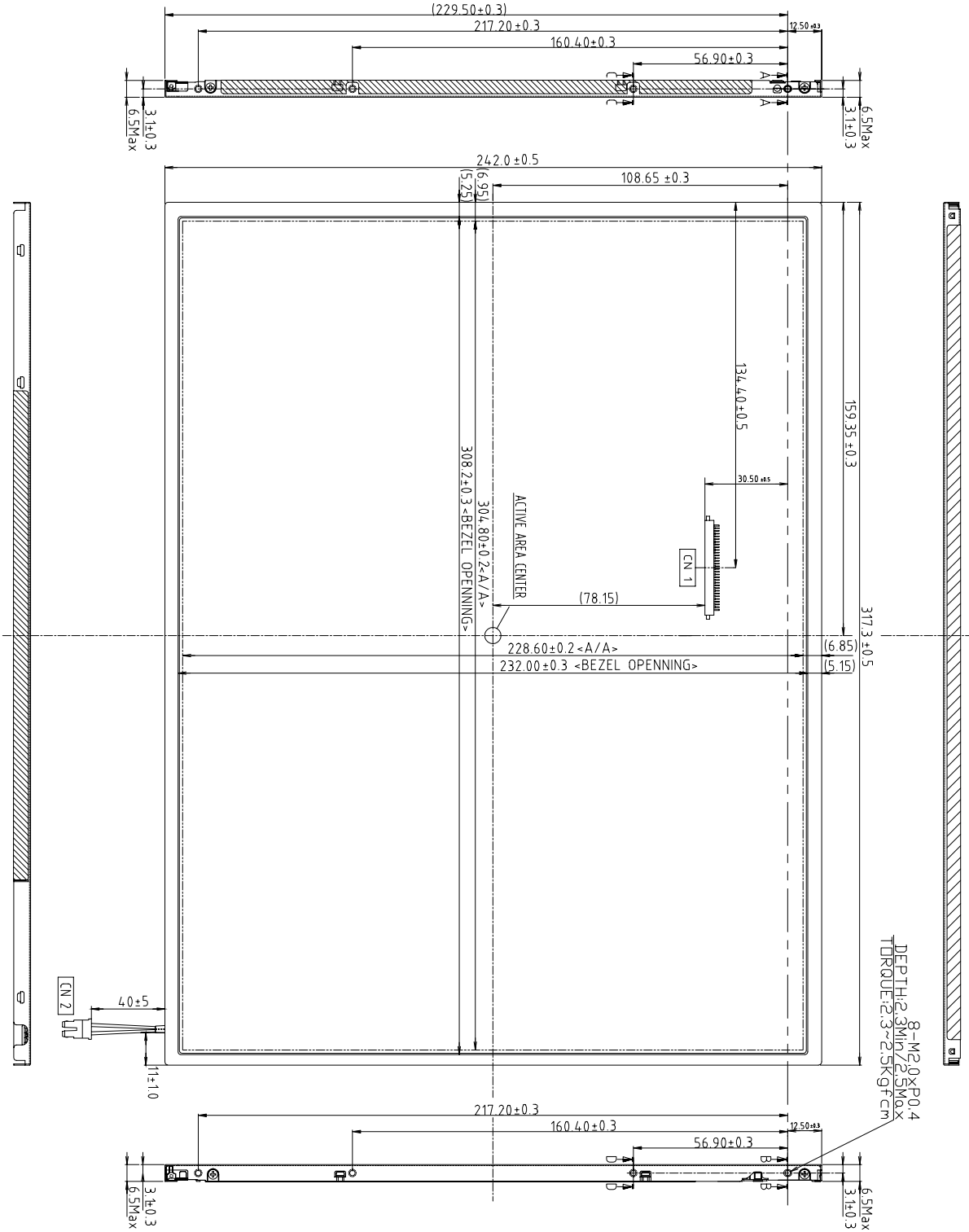

SPEC. NUMBER  
S864-1238

SPEC TITLE  
HV150UX1-100 Product Specification for Customer

PAGE  
25 OF 26



**PRODUCT GROUP**

REV

ISSUE DATE

TFT LCD PRODUCT

O

2005.08.22

**Figure 6. TFT-LCD Module Outline Dimensions (Rear view)**

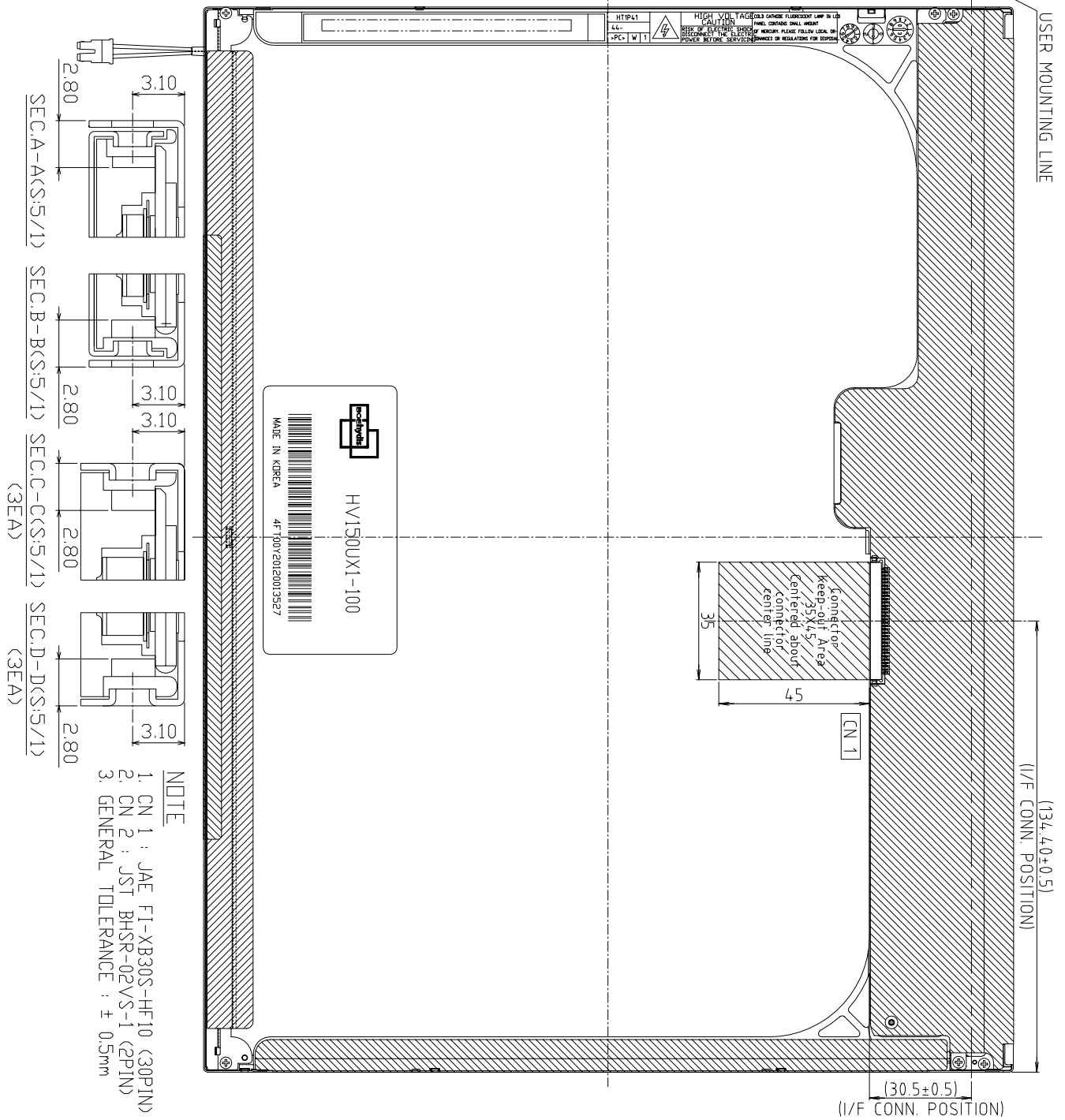

SPEC. NUMBER  
S864-1238

SPEC TITLE  
HV150UX1-100 Product Specification for Customer

PAGE  
26 OF 26