

**PROPRIETARY NOTE**

THIS SPECIFICATION IS THE PROPERTY OF HYDIS AND SHALL NOT BE REPRODUCED OR COPIED WITHOUT THE WRITTEN PERMISSION OF HYDIS AND MUST BE RETURNED TO HYDIS UPON ITS REQUEST

# TITLE : HV150UX2-100

## Product Specification for Customer

**HYDIS Technologies**

SPEC. NUMBER S864-1435	PRODUCT GROUP TFT LCD	REV. A	ISSUE DATE 2011.08.17	PAGE 1 OF 31
---------------------------	--------------------------	-----------	--------------------------	-----------------

B2005-C001-A (1/3)

A4(210 X 297)



 <b>HYDIS</b>	<b>PRODUCT GROUP</b>	REV	ISSUE DATE
	TFT LCD PRODUCT	A	2011.08.17

### REVISION HISTORY

REV.	ECN NO.	DESCRIPTION OF CHANGES	DATE	PREPARED
0		Internal release	2011.03.22	C.Shin
A	E1108-F004	Outline drawing Change ( Rear View / Label Point Change)	2011.08.17	S.T.Ko

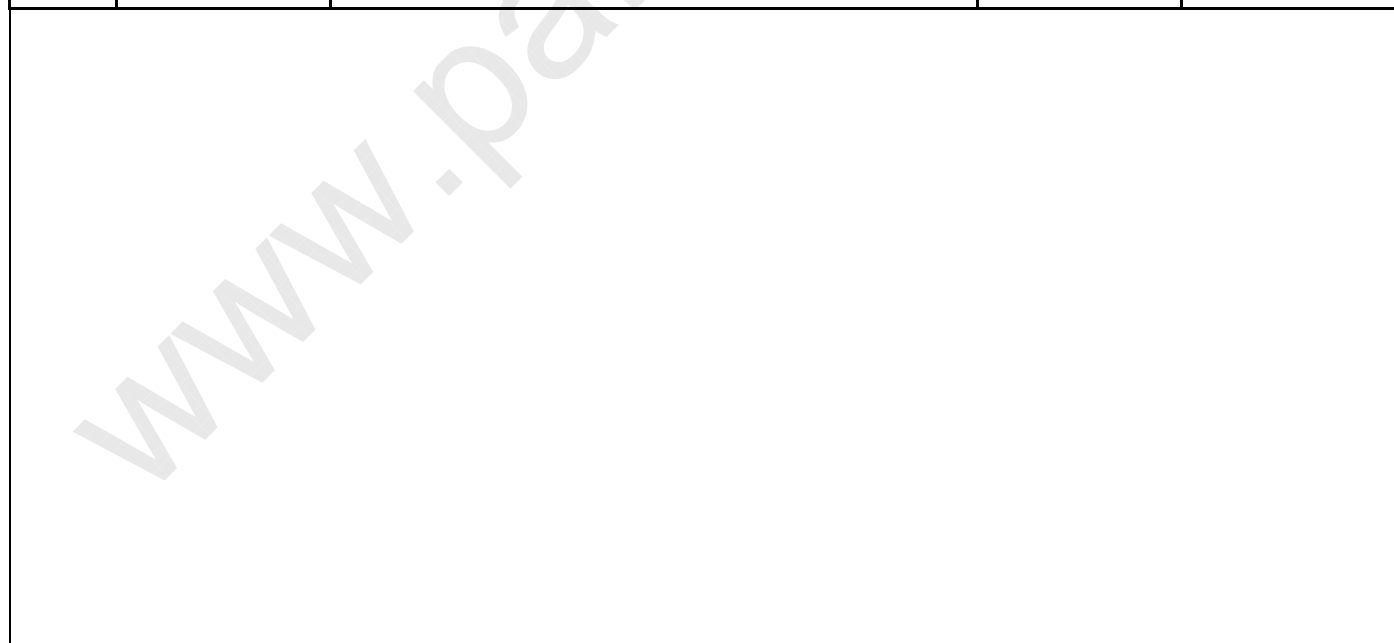

SPEC. NUMBER S864-1435	SPEC TITLE HV150UX2-100 Product Specification for Customer	PAGE 2 OF 31
---------------------------	---	-----------------

B2005-C001-A (2/3)

A4(210 X 297)

 <b>HYDIS</b>	<b>PRODUCT GROUP</b>	REV	ISSUE DATE
	TFT LCD PRODUCT	A	2011.08.17

## Contents

No	Item	Page
1.0	General Description	4
2.0	Absolute Maximum ratings	6
3.0	Electrical specifications.	7
4.0	Optical specifications.	8
5.0	Interface Connection	12
6.0	Signal Timing Specification	16
7.0	Signal Timing waveforms	16
8.0	Input Signals, Display Colors & Gray Scale of Colors	18
9.0	Power Sequence	19
10.0	Mechanical Characteristics	20
11.0	Reliability Test	21
12.0	Handling & Cautions.	22
13.0	Label	23
14.0	Packing information	25
15.0	EDID data table	27
Appendix	Outline drawing (Front and Rear)	30

SPEC. NUMBER S864-1435	SPEC TITLE HV150UX2-100 Product Specification for Customer	PAGE 3 OF 31
---------------------------	---	-----------------

B2005-C001-A (2/3)

A4(210 X 297)



# HYDIS

## PRODUCT GROUP

REV

ISSUE DATE

TFT LCD PRODUCT

A

2011.08.17

## 1.0 GENERAL DESCRIPTION

### 1.1 Introduction

HV150UX2-100 is a color active matrix TFT LCD module using amorphous silicon TFT's (Thin Film Transistors) as an active switching devices. This module has a 15.0 inch diagonally measured active area with UXGA resolutions (1600 horizontal by 1200 vertical pixel array). Each pixel is divided into RED, GREEN, BLUE dots which are arranged in vertical stripe and this module can display 262,144 colors.

This module applied LED backlight and a driving circuit on PCB assembly inside LCD panel.

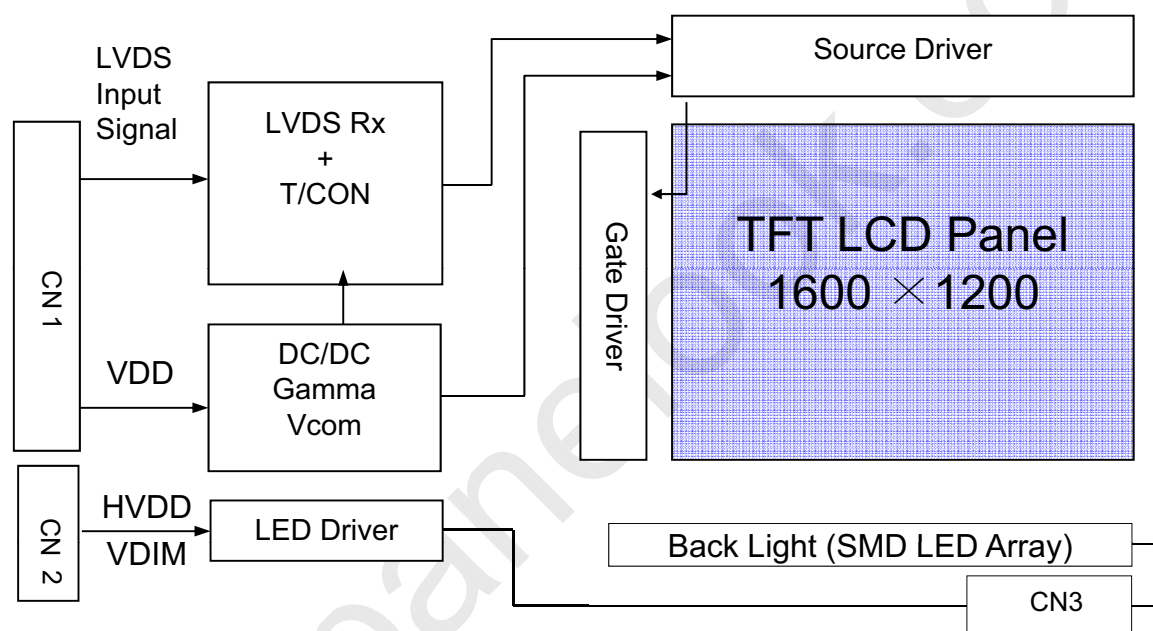

### 1.2 Features

- Thin and light weight
- Anti-Glare polarizer product
- Wide Temp Liquid Crystal
- 2 Channel LVDS Interface
- LED Side mounting Backlight
- 262,144 colors
- Data enable signal mode
- Side Mounting Frame
- Green Product (RoHS)
- On Board EDID chip

SPEC. NUMBER  
S864-1435

SPEC TITLE  
HV150UX2-100 Product Specification for Customer

PAGE  
4 OF 31

B2005-C001-A (2/3)

A4(210 X 297)

**HYDIS****PRODUCT GROUP**

REV

ISSUE DATE

TFT LCD PRODUCT

A

2011.08.17

**1.3 General Specification**

The followings are general specifications at the model HV150UX2-100. (listed in Table 1.)

<Table 1. General Specifications>

Parameter	Specification	Unit	Remarks
Active area	304.8 (H) × 228.6 (V) (15.0" diagonal)	mm	
Number of pixels	1600(H) × 1200(V)	pixels	
Pixel pitch	0.1905(H) × 0.1905(V)	mm	
Pixel arrangement	RGB Vertical stripe		
Display colors	262,144	colors	
Display mode	Normally Black		
Dimensional outline	317.3±0.5(H) × 243.0±0.5(V) × 7.0(D:max)	mm	
Weight	510 g (typ.)	g	
Surface treatment	AG(H40%)/2H		
Back-light	Bottom edge side, LED(54ea) Backlight		
LED Driving Block	Included in LCD, PWM dimming control		
Power consumption	$P_D$ : 1.65	W	
	$P_{BL}$ : 3.46	W	
	$P_{total}$ : 5.11	W	

SPEC. NUMBER  
S864-1435

SPEC TITLE  
HV150UX2-100 Product Specification for Customer

PAGE  
5 OF 31

B2005-C001-A (2/3)

A4(210 X 297)



## PRODUCT GROUP

REV

ISSUE DATE

TFT LCD PRODUCT

A

2011.08.17

## 2.0 ABSOLUTE MAXIMUM RATINGS

The followings are maximum values which, if exceed, may cause faulty operation or damage to the unit.

< Table 2. Absolute Maximum Ratings >

Ta=25+/-2°C

Parameter	Symbol	Min.	Max.	Unit	Remarks
Power Supply Voltage	V <sub>DD</sub>	-0.3	4.0	V	
Logic Supply Voltage	V <sub>IN</sub>	-0.3	V <sub>DD</sub> +0.3	V	
LED Power Supply Voltage	HV <sub>DD</sub>	0	28	V	
B/L LED Current	I <sub>LED</sub>		30	mA	Note 1
B/L LED Reverse Voltage	V <sub>R</sub>		5	V	
Operating Temperature	T <sub>OP</sub>	0	+50	°C	Note 1,2
LC Operating Temperature	T <sub>LC</sub>	-40	103	°C	
Storage Temperature	T <sub>SP</sub>	-20	+60	°C	

Note 1. Ambient temperature vs. allowable forward current are shown in the figure below.

Note 2. Temperature and relative humidity range are shown in the figure below.

90 % RH Max. ( 40 °C ≥ Ta)

Maximum wet - bulb temperature at 39 °C or less. (Ta > 40 °C) No condensation.

Ambient Temperature vs. Maximum Forward Current

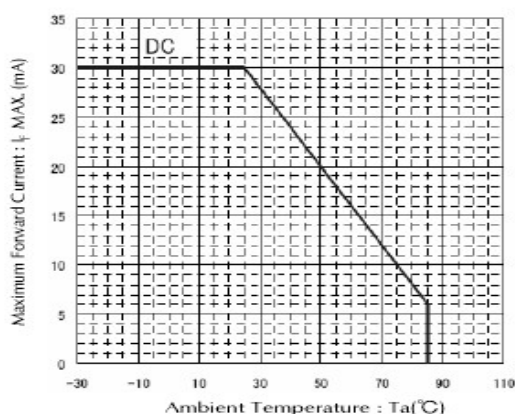

Relative Humidity

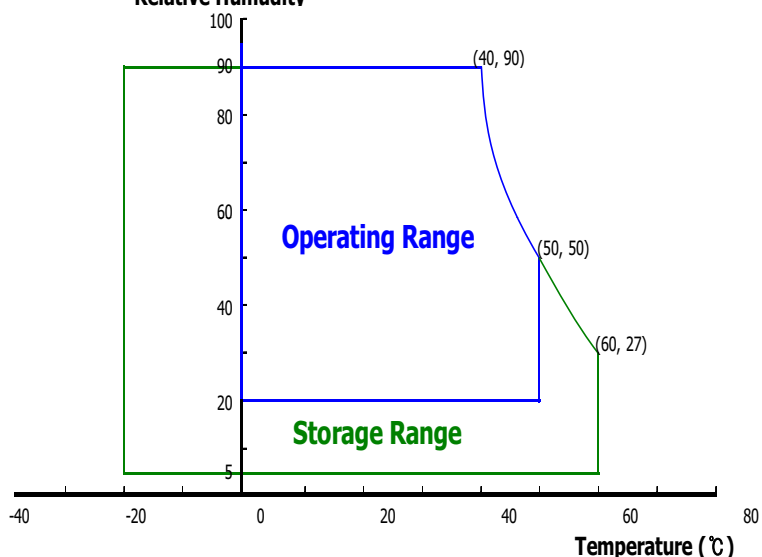

SPEC. NUMBER  
S864-1435

SPEC TITLE  
HV150UX2-100 Product Specification for Customer

PAGE  
6 OF 31

B2005-C001-A (2/3)

A4(210 X 297)

**HYDIS****PRODUCT GROUP**

REV

ISSUE DATE

TFT LCD PRODUCT

A

2011.08.17

**3.0 ELECTRICAL SPECIFICATIONS****3.1 Electrical Specifications**

&lt; Table 3. Electrical specifications &gt;

Parameter		Min.	Typ.	Max.	Unit	Remarks
Logic Power Supply Voltage	$V_{DD}$	3.0	3.3	3.6	V	Note 1
Logic Power Supply Current	$I_{DD}$	-	500	650	mA	Note 1
Back-light Power Supply Voltage	$HV_{DD}$	7.0	12.0	20	V	Note 2
Back-light Power Supply Current	$I_{HVDD}$	-	351		mA	Note 2,3
Back-light Power Consumption	$P_{BL}$	-	4.215		W	Note 2,3
LED Driver's Efficiency	$\eta$	-	82	-	%	Note 2,3
Back light PWM Frequency	$F_{PWM}$	200	320	350	Hz	
Back light PWM Duty Ratio	$D_{PWM}$	10		100	%	
High Level PWM Signal Voltage	$V_{PWMH}$	2.1	3.3	5.0	V	
Low Level PWM Signal Voltage	$V_{PWML}$	-	0	0.6	V	
High Level Differential Input Signal Voltage	$V_{IH}$	-	-	+100	mV	$V_{CM} = 1.2V$
Low Level Differential Input Signal Voltage	$V_{IL}$	-100	-	-	mV	
Back-light LED Voltage / Back-light LED Total Voltage	$V_{LED} / V_{BL}$	-	3.2 / 28.8	3.5 / 31.5	V	Note 4
Back-light LED Current / Back-light LED Total Current	$I_{LED} / I_{BL}$	-	20.0 / 120	21.0 / 122	mA	Note 4
Life Time		20,000	-	-	Hrs	
Power Consumption	$P_D$	-	1.65	2.15	W	Note 1
	$P_{LED}$	-	3.46	3.97	W	Note 4
	$P_{total}$	-	5.11	6.12	W	Note 1,4

Notes : 1. The supply voltage is measured and specified at the interface connector of LCM.

The current draw and power consumption specified is for 3.3V at 25°C.

a) Typ : Window XP pattern,      b) Max : Vertical Sub line pattern

2. The power supply voltage and current is measured and specified at the interface connector of LCM including LED Driver.

3. Reference value, which is measured with LED Driver for 12V.

4. Reference value, which is measured without LED Driver.

5. Calculated value for reference ( $V_{LED} \times I_{LED} \times \# \text{ of LEDs (54EA) }$ ).

SPEC. NUMBER  
S864-1435

SPEC TITLE  
HV150UX2-100 Product Specification for Customer

PAGE  
7 OF 31

B2005-C001-A (2/3)

A4(210 X 297)

 <b>HYDIS</b>	<b>PRODUCT GROUP</b>	REV	ISSUE DATE
	TFT LCD PRODUCT	A	2011.08.17

## 4.0 OPTICAL SPECIFICATION

### 4.1 Overview

The test of Optical specifications shall be measured in a dark room (ambient luminance  $\leq 1$  lux and temperature =  $25 \pm 2^\circ\text{C}$ ) with the equipment of Luminance meter system (Goniometer system and TOPCONE BM-5) and test unit shall be located at an approximate distance 50cm from the LCD surface at a viewing angle of  $\theta$  and  $\Phi$  equal to  $0^\circ$ . We refer to  $\theta\emptyset=0$  ( $=\theta_3$ ) as the 3 o'clock direction (the "right"),  $\theta\emptyset=90$  ( $=\theta_{12}$ ) as the 12 o'clock direction ("upward"),  $\theta\emptyset=180$  ( $=\theta_9$ ) as the 9 o'clock direction ("left") and  $\theta\emptyset=270$  ( $=\theta_6$ ) as the 6 o'clock direction ("bottom"). While scanning  $\theta$  and/or  $\emptyset$ , the center of the measuring spot on the Display surface shall stay fixed. The backlight should be operating for 30 minutes prior to measurement... VDD shall be  $3.3 \pm 0.3\text{V}$  at  $25^\circ\text{C}$ . Optimum viewing angle direction is 6 o'clock.

### 4.2 Optical Specifications

<Table 4. Optical Specifications>

Parameter		Symbol	Condition	Min.	Typ.	Max.	Unit	Remark			
Viewing Angle range	Horizontal	$\Theta_3$	CR > 10	80	85	-	Deg.	Note 1			
		$\Theta_9$		80	85	-	Deg.				
	Vertical	$\Theta_{12}$		80	85	-	Deg.				
		$\Theta_6$		80	85	-	Deg.				
Luminance Contrast ratio		CR	$\Theta = 0^\circ$	500	600	-		Note 2			
Center Luminance of White	1 Point	$Y_w$	$\Theta = 0^\circ$ IBL = 5.1W	170	200	-	cd/m <sup>2</sup>				
White Luminance uniformity	5 Points	$\Delta Y_5$		75	85	-	%				
	13 points	$\Delta Y_{13}$		60	65	-					
White Chromaticity		$W_x$	$\Theta = 0^\circ$	0.273	0.313	0.353		Note 3			
		$W_y$		0.289	0.329	0.369					
Reproduction of color	Red	$R_x$		0.555	0.595	0.635					
		$R_y$		0.310	0.350	0.390					
	Green	$G_x$		0.304	0.344	0.384					
		$G_y$		0.539	0.579	0.619					
	Blue	$B_x$		0.115	0.155	0.195					
		$B_y$		0.085	0.125	0.165					
Response Time		$T_r + T_d$		Ta = $25^\circ\text{C}$ $\Theta = 0^\circ$	-	45			-	ms	
Color Reproduction		-		-	-	45			-	%	
Cross Talk		CT	$\Theta = 0^\circ$	-	-	2.0	%				

SPEC. NUMBER S864-1435	SPEC TITLE HV150UX2-100 Product Specification for Customer	PAGE 8 OF 31
---------------------------	---	-----------------

B2005-C001-A (2/3)

A4(210 X 297)



 <b>HYDIS</b>	<b>PRODUCT GROUP</b>	REV	ISSUE DATE
	TFT LCD PRODUCT	A	2011.08.17

- Notes :
- Viewing angle is the angle at which the contrast ratio is greater than 10. The viewing angles are determined for the horizontal or 3, 9 o'clock direction and the vertical or 6, 12 o'clock direction with respect to the optical axis which is normal to the LCD surface (see FIGURE1 as below).
  - Contrast measurements shall be made at viewing angle of  $\Theta = 0$  and at the center of the LCD surface. Luminance shall be measured with all pixels in the view field set first to white, then to the dark (black) state .  
Luminance Contrast Ratio (CR) is defined mathematically as  $CR = \text{Luminance when displaying a white raster} / \text{Luminance when displaying a black raster}$ .
  - The color chromaticity coordinates specified in Table 4. shall be calculated from the spectral data measured with all pixels first in red, green, blue, and white. Measurements shall be made at the center of the panel.

### 4.3 Optical measurements

**Figure 1. Measurement Set Up**

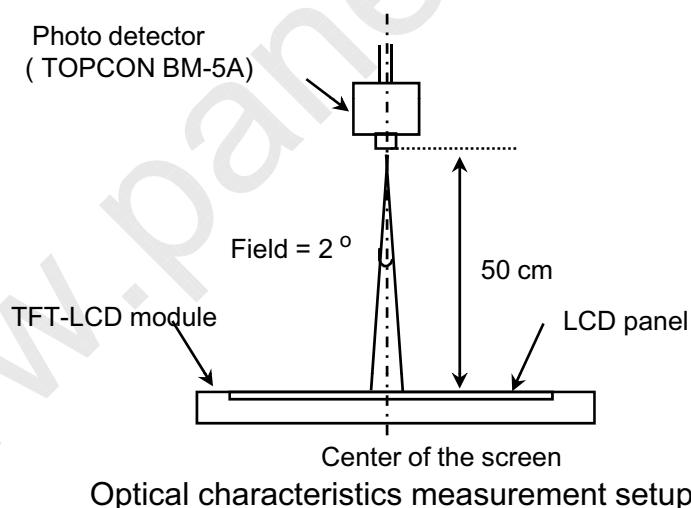

SPEC. NUMBER S864-1435	SPEC TITLE HV150UX2-100 Product Specification for Customer	PAGE 9 OF 31
---------------------------	---	-----------------

 <b>HYDIS</b>	<b>PRODUCT GROUP</b>	REV	ISSUE DATE
	TFT LCD PRODUCT	A	2011.08.17

**Figure 2. White Luminance (Center) and Uniformity Measurement Locations (5 and 13 points)**

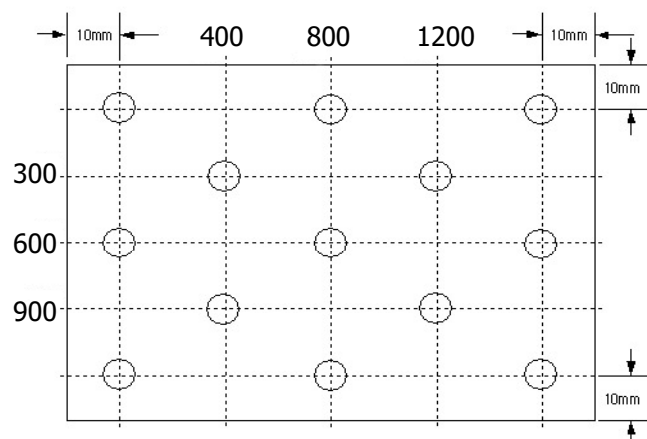

White luminance : Center Luminance of white is defined as luminance values of center 1 point. Luminance shall be measured with all pixels in the view field set first to white. This measurement shall be taken at the locations shown in FIGURE 2.

Uniformity of 5 points and 13 points : The White luminance uniformity on LCD surface is expressed as :  $\Delta Y5 = \text{Minimum Luminance of five points} / \text{Maximum Luminance of five points}$  (see FIGURE 2) ,  $\Delta Y13 = \text{Minimum Luminance of 13 points} / \text{Maximum Luminance of 13 points}$  (see FIGURE 2.)

**Figure 3. Response Time Testing**

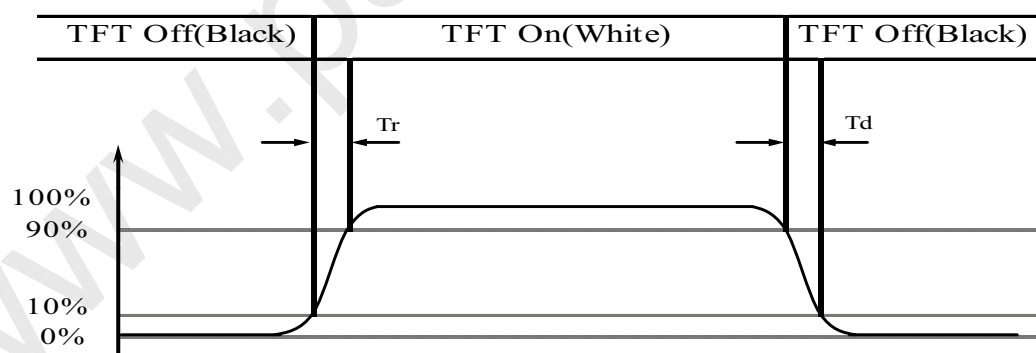

The electro-optical response time measurements shall be made as shown in FIGURE 3 by switching the data input signal ON and OFF. The times needed for the luminance to change from 10% to 90% is  $T_r$  and 90% to 10% is  $T_d$ .

SPEC. NUMBER S864-1435	SPEC TITLE HV150UX2-100 Product Specification for Customer	PAGE 10 OF 31
---------------------------	---	------------------

**PRODUCT GROUP**

REV

ISSUE DATE

TFT LCD PRODUCT

A

2011.08.17

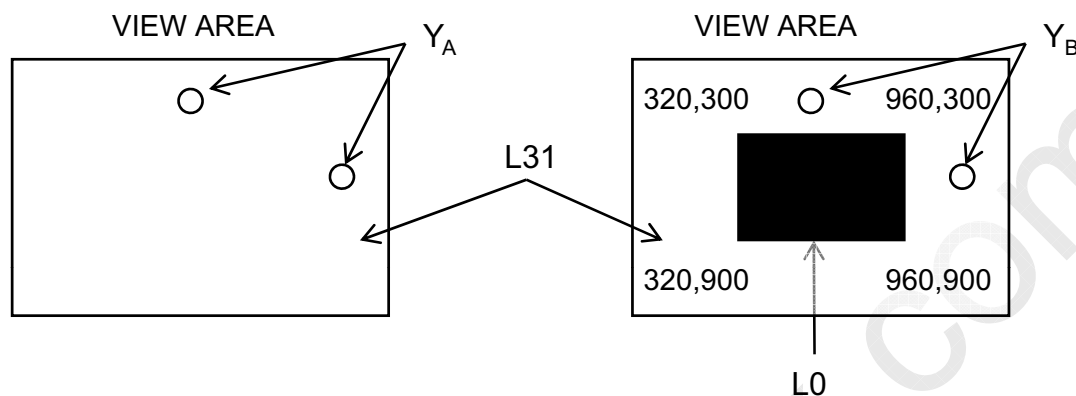
**Figure 4. Cross Modulation Test Description**

Test point of  $Y_A / Y_B$  : Horizontal - 1400, 600  
Vertical - 800, 150

$$\text{Cross-Talk (\%)} = \left| \frac{Y_B - Y_A}{Y_B} \right| \times 100$$

Where:

$Y_A$  = Initial luminance of measured area ( $\text{cd}/\text{m}^2$ )

$Y_B$  = Subsequent luminance of measured area ( $\text{cd}/\text{m}^2$ )

The location measured will be exactly same position in both patterns

Cross-Talk of one area of the LCD surface by another shall be measured by comparing the luminance ( $Y_A$ ) of a 25mm diameter area, with all display pixels set to a gray level, to the luminance ( $Y_B$ ) of that same area when any adjacent area is driven dark (Refer to FIGURE 4).

SPEC. NUMBER  
S864-1435

SPEC TITLE  
HV150UX2-100 Product Specification for Customer

PAGE  
11 OF 31

B2005-C001-A (2/3)

A4(210 X 297)

**HYDIS****PRODUCT GROUP**

REV

ISSUE DATE

TFT LCD PRODUCT

A

2011.08.17

**5.0 INTERFACE CONNECTION.****5.1 Electrical Interface Connection**

Panel side : FI-XB30SL-HF10 (JAE, for Signal) + DF19L-14P-1H (HIROSE, for LED)

**<Pin assignments for the interface connector>**  
**FI-XB30SL-HF10 (JAE)**

Terminal	Symbol	Functions
1	E_CLKIN+	+LVDS differential Clock input (Even pixel)
2	E_CLKIN-	-LVDS differential Clock input (Even pixel)
3	VSS	GND
4	E_RIN2+	+LVDS differential data input (B2~B5,HS,VS,DE) (Even pixel)
5	E_RIN2-	-LVDS differential data input (B2~B5,HS,VS,DE) (Even pixel)
6	VSS	GND
7	E_RIN1+	+LVDS differential data input (G1~G5,B0,B1) (Even pixel)
8	E_RIN1-	-LVDS differential data input (G1~G5,B0,B1) (Even pixel)
9	VSS	GND
10	E_RIN0+	+LVDS differential data input (R0~R5,G0) (Even pixel)
11	E_RIN0-	-LVDS differential data input (R0~R5,G0) (Even pixel)
12	VSS	GND
13	O_CLKIN+	+LVDS differential Clock input (Odd pixel)
14	O_CLKIN-	-LVDS differential Clock input (Odd pixel)
15	VSS	GND
16	O_RIN2+	+LVDS differential data input (B2~B5,HS,VS,DE) (Odd pixel)
17	O_RIN2-	-LVDS differential data input (B2~B5,HS,VS,DE) (Odd pixel)
18	VSS	GND
19	O_RIN1+	+LVDS differential data input (G1~G5,B0,B1) (Odd pixel)
20	O_RIN1-	-LVDS differential data input (G1~G5,B0,B1) (Odd pixel)
21	VSS	GND
22	O_RIN0+	+LVDS differential data input (R0~R5,G0) (Odd pixel)
23	O_RIN0-	-LVDS differential data input (R0~R5,G0) (Odd pixel)
24	DATA <sub>EDID</sub> -	Reserved (for DATA <sub>EDID</sub> )
25	CLK <sub>EDID</sub>	Reserved (for Clk <sub>EDID</sub> )
26	NC	Reserved (for Supplier test point)
27	VDD	Power Supply : +3.3V (typical)
28	VDD	Power Supply : +3.3V (typical)
29	VDD	Power Supply : +3.3V (typical)
30	GND	Low

SPEC. NUMBER  
S864-1435

SPEC TITLE  
HV150UX2-100 Product Specification for Customer

PAGE  
12 OF 31

B2005-C001-A (2/3)

A4(210 X 297)

**HYDIS****PRODUCT GROUP**

REV

ISSUE DATE

TFT LCD PRODUCT

A

2011.08.17

**<Pin assignments for the LED connector>  
DF19L-14P-1H (HIROSE)**

Terminal	Symbol	Functions
1	VSS	Ground
2	HVDD	Power Supply: +12V
3	HVDD	Power Supply: +12V
4	HVDD	Power Supply: +12V
5	HVDD	Power Supply: +12V
6	HVDD	Power Supply: +12V
7	NC	No Connection
8	BL on	BL on/off
9	Vdim	PWM Brightness Control
10	VSS	Ground
11	VSS	Ground
12	VSS	Ground
13	VSS	Ground
14	VSS	Ground

SPEC. NUMBER  
S864-1435SPEC TITLE  
HV150UX2-100 Product Specification for CustomerPAGE  
13 OF 31

B2005-C001-A (2/3)

A4(210 X 297)

	<b>PRODUCT GROUP</b>	REV	ISSUE DATE
	TFT LCD PRODUCT	A	2011.08.17

## 5-2. LVDS Interface

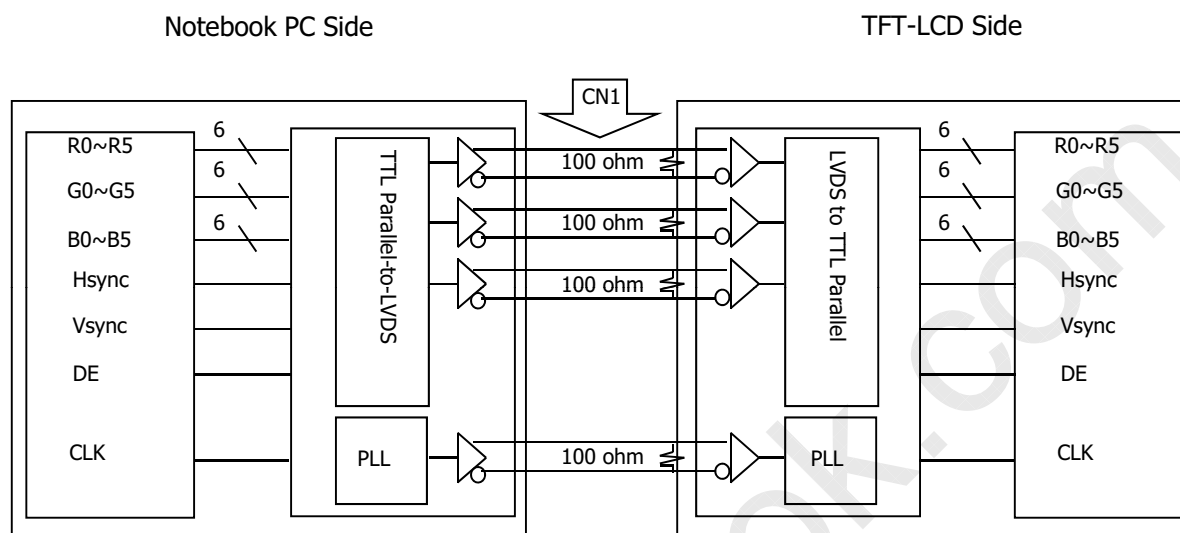

Note. Transmitter : Thine THC63LVDM63A or equivalent. Transmitter is not contained in Module.

## 5.3.LVDS Input signal

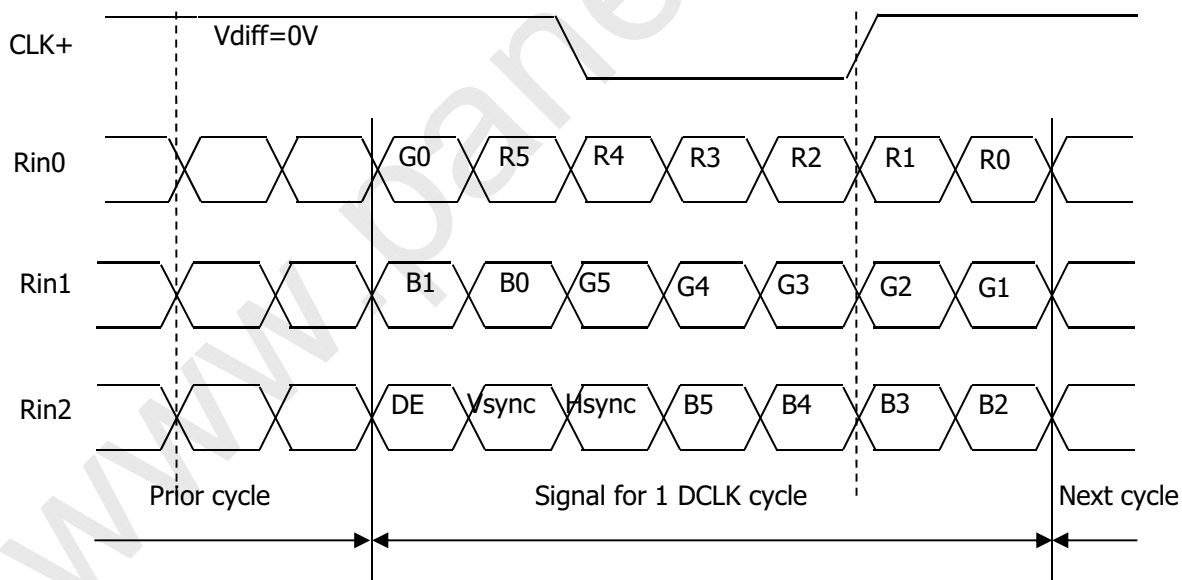

Note. Pin connection in case of using Thine THC63LVDM63A

SPEC. NUMBER S864-1435	SPEC TITLE HV150UX2-100 Product Specification for Customer	PAGE 14 OF 31
---------------------------	---	------------------

**HYDIS****PRODUCT GROUP**

REV

ISSUE DATE

TFT LCD PRODUCT

A

2011.08.17

&lt;Table 6. Pin connection in case of using Thine THC63LVDM63A&gt;

Input signal	Transmitter	Input signal	Transmitter
DCLK	CLK IN(26)	G4	TB3(10)
R0	TA0(44)	G5	TB4(12)
R1	TA1(45)	B0	TB5(13)
R2	TA2(47)	B1	TB6(15)
R3	TA3(48)	B2	TC0(16)
R4	TA4(1)	B3	TC1(18)
R5	TA5(3)	B4	TC2(19)
G0	TA6(4)	B5	TC3(20)
G1	TB0(6)	Hsync	TC4(22)
G2	TB1(7)	Vsync	TC5(23)
G3	TB2(9)	DE	TC6(25)

**5.4.Back light Interface****CN2 LED FPC Connector (20397-008E, Manufactured by I-PEX)**

Pin No.	Symbol	Function	Remark
1	Anode	LED Anode Power Supply	LED Anode Power Supply
2	Anode	LED Anode Power Supply	
3	NC	Non-Connection	LED Cathode Power Supply
4	NC	Non-Connection	
5	Cathode1	LED Cathode Power Supply	
6	Cathode2	LED Cathode Power Supply	
7	Cathode3	LED Cathode Power Supply	
8	Cathode4	LED Cathode Power Supply	

SPEC. NUMBER  
S864-1435SPEC TITLE  
HV150UX2-100 Product Specification for CustomerPAGE  
15 OF 31

B2005-C001-A (2/3)

A4(210 X 297)

 <b>HYDIS</b>	<b>PRODUCT GROUP</b>	REV	ISSUE DATE
	TFT LCD PRODUCT	A	2011.08.17

## 6.0. SIGNAL TIMING SPECIFICATION

The specification of the signal timing parameters are listed in Table 8.

<Table 8. Signal Timing Specification.>

Item	Symbols	Min	Typ	Max	Unit
Frame Period	T1	-	1250	-	Lines
Vertical Display Period	T2	-	1200	-	Lines
One line Scanning Period	T3	-	2160	-	Clocks
Horizontal Display Period	T4	-	1600	-	Clocks
Clock Frequency	1/T5	-	81	-	MHz

## 7.0 SIGNAL TIMING WAVEFORMS

### 7.1 Timing wave forms of interface signal

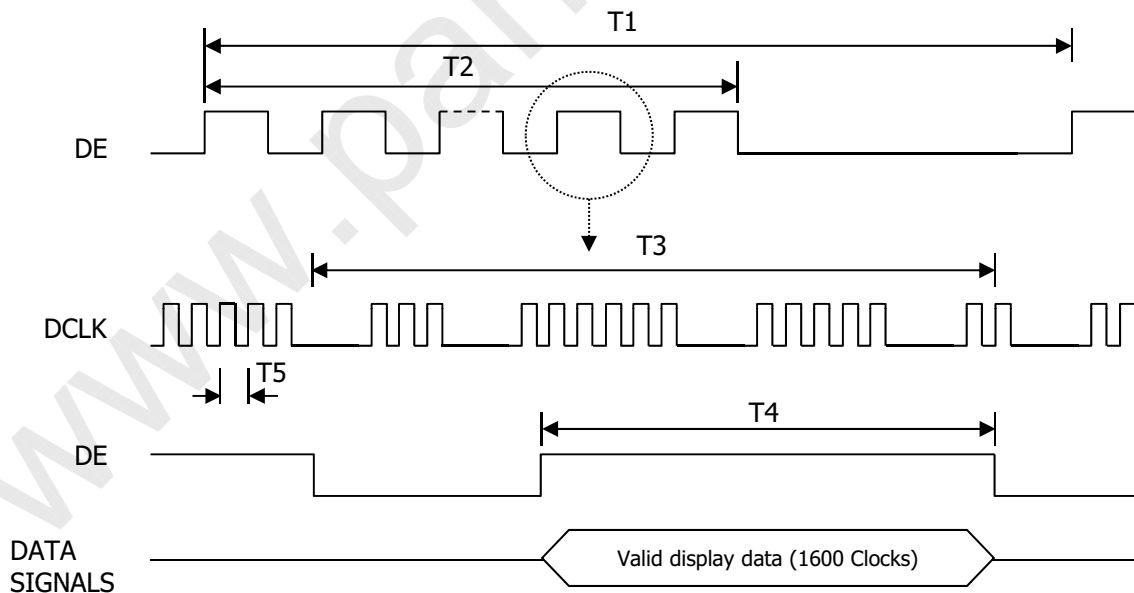

SPEC. NUMBER S864-1435	SPEC TITLE HV150UX2-100 Product Specification for Customer	PAGE 16 OF 31
---------------------------	---	------------------





## PRODUCT GROUP

REV

ISSUE DATE

TFT LCD PRODUCT

A

2011.08.17

### 7.2 LVDS Rx Interface Timing Parameter

The specification of the LVDS Rx interface timing parameter is listed in Table 9.

<Table 9. LVDS Rx Interface Timing Specification>

Item	Symbol	Min	Typ	Max	Unit	Remark
PLL Set	tRPLL	-	-	10.0	msec	
CLKIN Period	tRICP	11.77	12.35	21.16	nsec	
Input Data 0	tRIP0	-0.4	0.0	+0.4	nsec	
Input Data 1	tRIP1	tRICP/7-0.4	tRICP/7	tRICP/7+0.4	nsec	
Input Data 2	tRIP2	2 × tRICP/7-0.4	2 × tRICP/7	2 × tRICP/7+0.4	nsec	
Input Data 3	tRIP3	3 × tRICP/7-0.4	3 × tRICP/7	3 × tRICP/7+0.4	nsec	
Input Data 4	tRIP4	4 × tRICP/7-0.4	4 × tRICP/7	4 × tRICP/7+0.4	nsec	
Input Data 5	tRIP5	5 × tRICP/7-0.4	5 × tRICP/7	5 × tRICP/7+0.4	nsec	
Input Data 6	tRIP6	6 × tRICP/7-0.4	6 × tRICP/7	6 × tRICP/7+0.4	nsec	

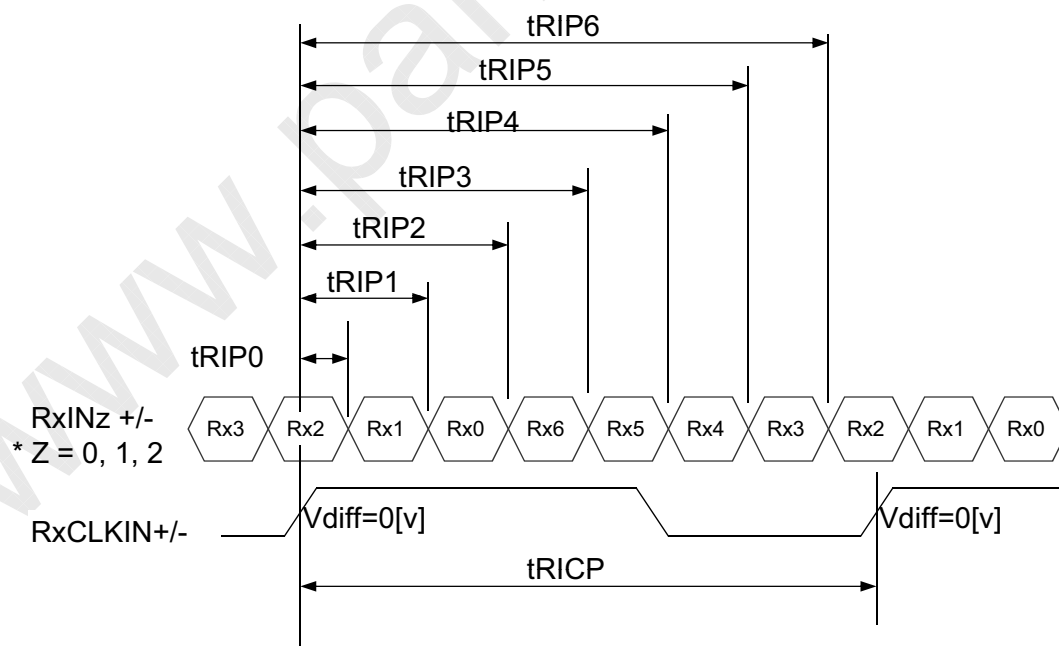

SPEC. NUMBER  
S864-1435

SPEC TITLE  
HV150UX2-100 Product Specification for Customer

PAGE  
17 OF 31

B2005-C001-A (2/3)

A4(210 X 297)

**HYDIS****PRODUCT GROUP**

REV

ISSUE DATE

TFT LCD PRODUCT

A

2011.08.17

**8.0 INPUT SIGNALS, BASIC DISPLAY COLORS & GRAY SCALE OF COLORS**

Each color is displayed in 64 gray scales from a 6 bit data signal input. A total of 262,144 colors are derived from the resultant 18 bit data. Table 10. shows the input signals, basic display colors and gray scale for each color.

&lt;Table 10. Input signals, Basic display colors and Gray scale for each color.&gt;

	Colors & Gray scale	Data signal																	
		R0	R1	R2	R3	R4	R5	G0	G1	G2	G3	G4	G5	B0	B1	B2	B3	B4	B5
Basic colors	Black	0	0	0	0	0	0	0	0	0	0	0	0	0	0	0	0	0	0
	Blue	0	0	0	0	0	0	0	0	0	0	0	0	1	1	1	1	1	1
	Green	0	0	0	0	0	0	1	1	1	1	1	1	0	0	0	0	0	0
	Light Blue	0	0	0	0	0	0	1	1	1	1	1	1	1	1	1	1	1	1
	Red	1	1	1	1	1	1	0	0	0	0	0	0	0	0	0	0	0	0
	Purple	1	1	1	1	1	1	0	0	0	0	0	0	1	1	1	1	1	1
	Yellow	1	1	1	1	1	1	1	1	1	1	1	1	0	0	0	0	0	0
White	1	1	1	1	1	1	1	1	1	1	1	1	1	1	1	1	1	1	
Gray scale of Red	Black	0	0	0	0	0	0	0	0	0	0	0	0	0	0	0	0	0	0
	△	1	0	0	0	0	0	0	0	0	0	0	0	0	0	0	0	0	0
	Darker	0	1	0	0	0	0	0	0	0	0	0	0	0	0	0	0	0	0
	△				↓						↓						↓		
	▽				↓						↓						↓		
	Brighter	1	0	1	1	1	1	0	0	0	0	0	0	0	0	0	0	0	0
Gray scale of Green	Black	0	0	0	0	0	0	0	0	0	0	0	0	0	0	0	0	0	0
	△	0	0	0	0	0	0	1	0	0	0	0	0	0	0	0	0	0	0
	Darker	0	0	0	0	0	0	0	1	0	0	0	0	0	0	0	0	0	0
	△				↓						↓						↓		
	▽				↓						↓						↓		
	Brighter	0	0	0	0	0	0	1	0	1	1	1	1	0	0	0	0	0	0
Gray scale of Blue	Black	0	0	0	0	0	0	0	0	0	0	0	0	0	0	0	0	0	0
	△	0	0	0	0	0	0	0	0	0	0	0	0	1	0	0	0	0	0
	Darker	0	0	0	0	0	0	0	0	0	0	0	0	0	1	0	0	0	0
	△				↓						↓						↓		
	▽				↓						↓						↓		
	Brighter	0	0	0	0	0	0	0	0	0	0	0	0	1	0	1	1	1	1
Gray scale of White & Black	Black	0	0	0	0	0	0	0	0	0	0	0	0	0	0	0	0	0	0
	△	1	0	0	0	0	0	1	0	0	0	0	0	1	0	0	0	0	0
	Darker	0	1	0	0	0	0	0	1	0	0	0	0	0	1	0	0	0	0
	△				↓						↓						↓		
	▽				↓						↓						↓		
	Brighter	1	0	1	1	1	1	1	0	1	1	1	1	1	0	1	1	1	1
White	1	1	1	1	1	1	1	1	1	1	1	1	1	1	1	1	1	1	

SPEC. NUMBER

S864-1435

SPEC TITLE

HV150UX2-100 Product Specification for Customer

PAGE

18 OF 31

B2005-C001-A (2/3)

A4(210 X 297)



## PRODUCT GROUP

REV

ISSUE DATE

TFT LCD PRODUCT

A

2011.08.17

### 9.0 POWER SEQUENCE

To prevent a latch-up or DC operation of the LCD module, the power on/off sequence shall be as shown in below

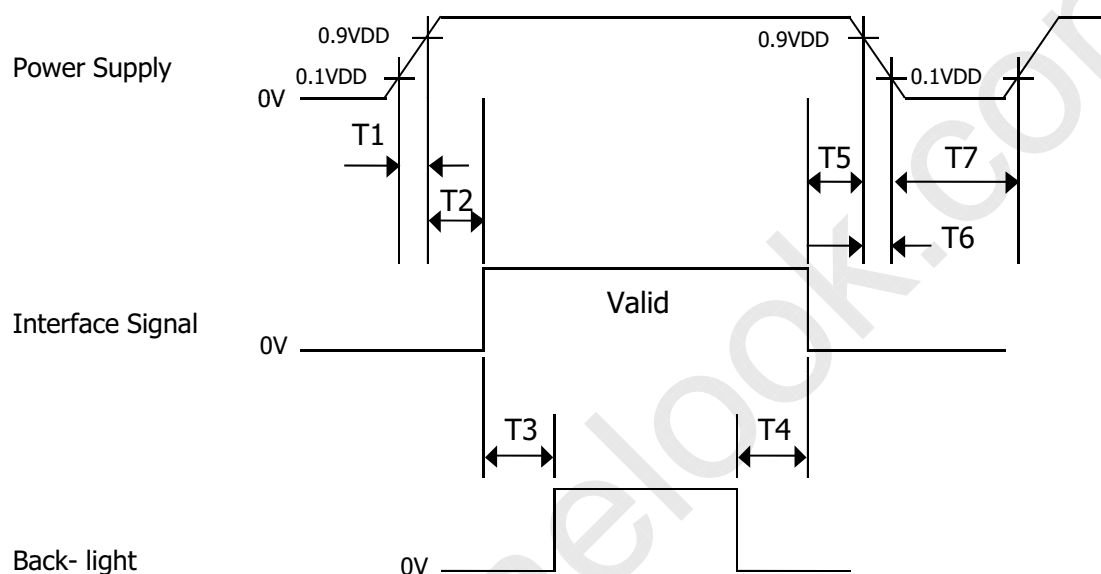

- $T1 \leq 10 \text{ ms}$
- $0 \leq T2 \leq 50 \text{ ms}$
- $200\text{ms} \leq T3$
- $0 \leq T4$
- $0 \leq T5$
- $0 \leq T6 \leq 10\text{ms}$
- $150\text{ms} \leq T7$

Notes : 1. When the power supply VDD is 0V, Keep the level of input signals on the low or keep high impedance.

2. Do not keep the interface signal high impedance when power is on.

Back Light must be turn on after power for logic and interface signal are valid.

SPEC. NUMBER  
S864-1435

SPEC TITLE  
HV150UX2-100 Product Specification for Customer

PAGE  
19 OF 31

B2005-C001-A (2/3)

A4(210 X 297)

**HYDIS****PRODUCT GROUP**

REV

ISSUE DATE

TFT LCD PRODUCT

A

2011.08.17

**10.0 MECHANICAL CHARACTERISTICS****10.1 Dimensional Requirements**

FIGURE 5 (located in Appendix) shows mechanical outlines for the model HV150UX2-100. Other parameters are shown in Table 11.

&lt;Table 11. Dimensional Parameters&gt;

Parameter	Specification	Unit
Active Area	304.8 (H) × 228.6 (V)	mm
Dimensional outline	317.3 ± 0.5 × 243.0 ± 0.5 × 7.0 max	mm
Weight	510 (typ.)	gram
Back-light	SMD LED(54EA) Array	

**10.2 Mounting**

See FIGURE 5. (shown in Appendix)

Parameter	Specification	Unit
Torque of side mounting screw	2.5(Max.)	kgf

**10.3 Anti-Glare and Polarizer Hardness.**

The surface of the LCD has an anti-glare coating to minimize reflection and a coating to reduce scratching.

**10.4 Light Leakage**

There shall not be visible light from the back-lighting system around the edges of the screen as seen from a distance 50cm from the screen with an overhead light level of 350lux.

SPEC. NUMBER  
S864-1435

SPEC TITLE  
HV150UX2-100 Product Specification for Customer

PAGE  
20 OF 31

B2005-C001-A (2/3)

A4(210 X 297)

**HYDIS****PRODUCT GROUP**

REV

ISSUE DATE

TFT LCD PRODUCT

A

2011.08.17

**11.0 RELIABILITY TEST**

The Reliability test items and its conditions are shown in table 12.

&lt;Table 12. Reliability test&gt;

No	Test Items	Conditions
1	High temperature storage test	Ta = 60 °C , 240 hrs
2	Low temperature storage test	Ta = -20 °C , 240 hrs
3	High temperature & high humidity operation test	Ta = 50 °C , 80%RH, 240hrs
4	High temperature operation test	Ta = 50 °C , 240hrs
5	Low temperature operation test	Ta = 0 °C , 240hrs
6	Thermal shock	Ta = -20 °C ↔ 60 °C (0.5 hr), 100 cycle
7	Vibration test (non-operating)	1.5G,10~300Hz for X,Y,Z axis 30 minutes for each axis
8	Shock test (non-operating)	220G,2msec,half sine (6 times)
9	Electro-static discharge test (non-operating)	Air : 150 pF, 330Ω, 15 KV Contact : 150 pF, 330Ω, 8 KV

SPEC. NUMBER  
S864-1435SPEC TITLE  
HV150UX2-100 Product Specification for CustomerPAGE  
21 OF 31

B2005-C001-A (2/3)

A4(210 X 297)

 <b>HYDIS</b>	<b>PRODUCT GROUP</b>	REV	ISSUE DATE
	TFT LCD PRODUCT	A	2011.08.17

## 12.0 HANDLING & CAUTIONS

- (1) Cautions when taking out the module
  - Pick the pouch only, when taking out module from a shipping package.
- (2) Cautions for handling the module
  - As the electrostatic discharges may break the LCD module, handle the LCD module with care. Peel a protection sheet off from the LCD panel surface as slowly as possible.
  - As the LCD panel and back - light element are made from fragile glass material, impulse and pressure to the LCD module should be avoided.
  - As the surface of the polarizer is very soft and easily scratched, use a soft dry cloth without chemicals for cleaning.
  - Do not pull the interface connector in or out while the LCD module is operating.
  - Put the module display side down on a flat horizontal plane.
  - Handle connectors and cables with care.
- (3) Cautions for the operation
  - When the module is operating, do not lose CLK, ENAB signals. If any one of these signals is lost, the LCD panel would be damaged.
  - Obey the supply voltage sequence. If wrong sequence is applied, the module would be damaged.
- (4) Cautions for the atmosphere
  - Dew drop atmosphere should be avoided.
  - Do not store and/or operate the LCD module in a high temperature and/or humidity atmosphere. Storage in an electro-conductive polymer packing pouch and under relatively low temperature atmosphere is recommended.
- (5) Cautions for the module characteristics
  - Do not apply fixed pattern data signal to the LCD module at product aging.
  - Applying fixed pattern for a long time may cause image sticking.
- (6) Other cautions
  - Do not disassemble and/or re-assemble LCD module.
  - Do not re-adjust variable resistor or switch etc.
  - When returning the module for repair or etc., Please pack the module not to be broken. We recommend to use the original shipping packages.

SPEC. NUMBER S864-1435	SPEC TITLE HV150UX2-100 Product Specification for Customer	PAGE 22 OF 31
---------------------------	---	------------------

B2005-C001-A (2/3)

A4(210 X 297)

 <b>HYDIS</b>	<b>PRODUCT GROUP</b>	REV	ISSUE DATE
	TFT LCD PRODUCT	A	2011.08.17

### 13.0 LABELS

#### 13.1 Product Label

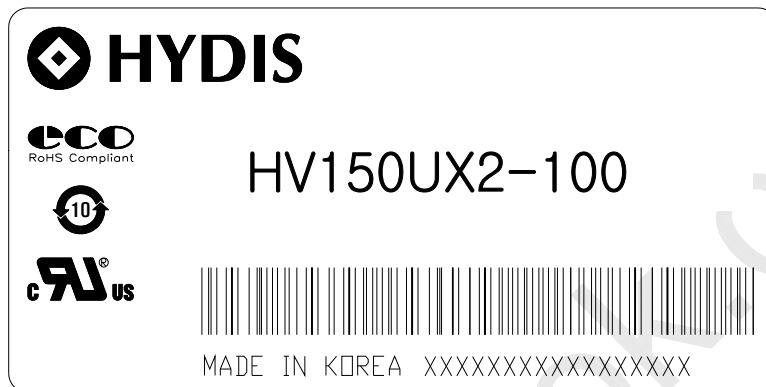

#### HYDIS Barcode

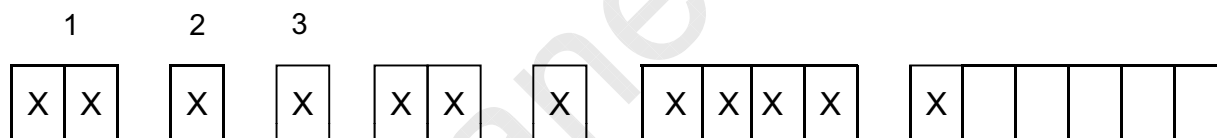

No 1. Control Number

No 5. Month (1, 2, 3,..., 9, X, Y, Z)

No 2. Rank / Grade

No 6. FG Code

No 3. Line Classification  
(HYDIS : H)

No 7. Serial Number

No 4. Year (10 : 2010, 11 : 2011, ...)

SPEC. NUMBER S864-1435	SPEC TITLE HV150UX2-100 Product Specification for Customer	PAGE 23 OF 31
---------------------------	---	------------------



	<b>PRODUCT GROUP</b>	REV	ISSUE DATE
	TFT LCD PRODUCT	A	2011.08.17

### 13.2 Packing Label

Label Size: 108 mm (L) × 56 mm (W)

Contents

Model: HV150UX2-100

Q`ty: Module Q`ty in one box

Serial No.: Box Serial No. See next figure for detail description.

Date: Packing Date

FG Code: FG Code of Product

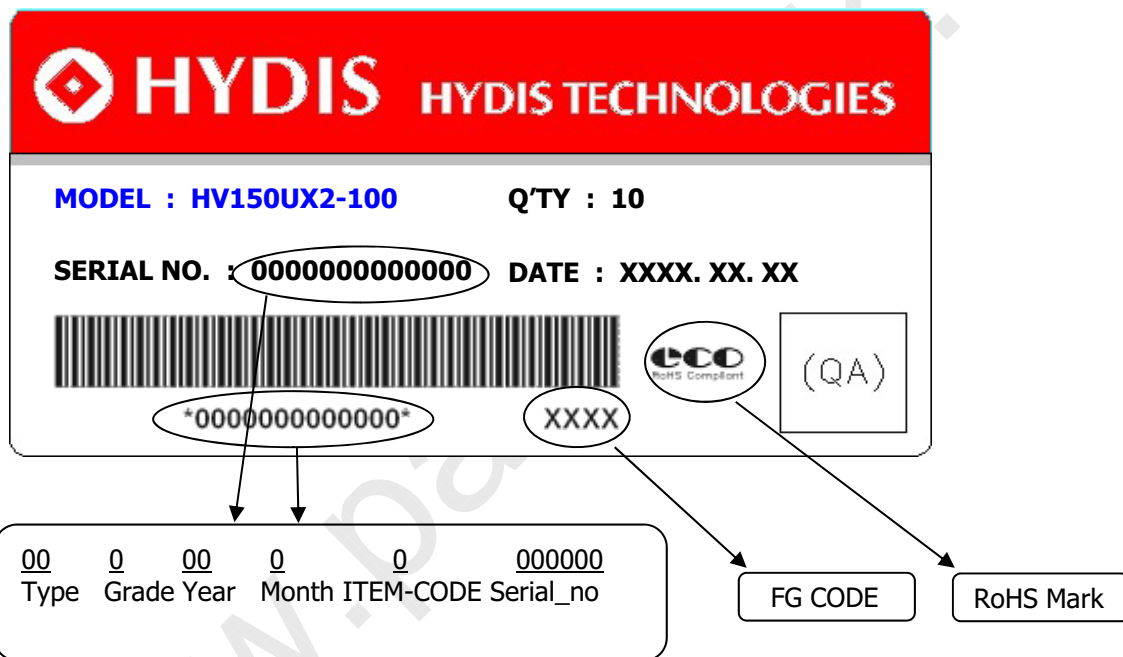

SPEC. NUMBER S864-1435	SPEC TITLE HV150UX2-100 Product Specification for Customer	PAGE 24 OF 31
---------------------------	---	------------------



 <b>HYDIS</b>	<b>PRODUCT GROUP</b>	REV	ISSUE DATE
	TFT LCD PRODUCT	A	2011.08.17

## 14.0 PACKING INFORMATION

### 14.1 Packing order

Put Pad into the box.

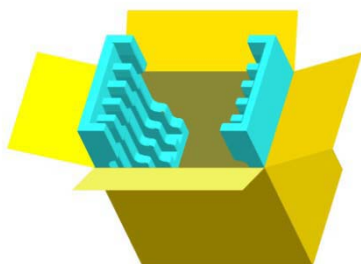

Put silica gels in the box.

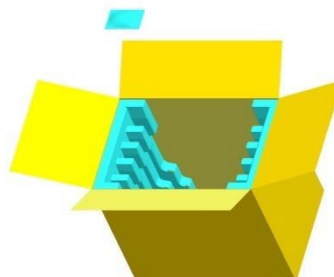

After sealing the box, attach Packing Label on the attach position sign area of the box.

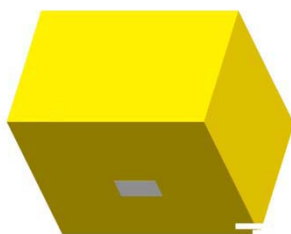

Place a cover on the top of the box.

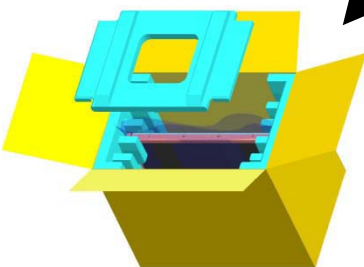

As shown in the figure, place the Modules bundled by shielding bag in the box.

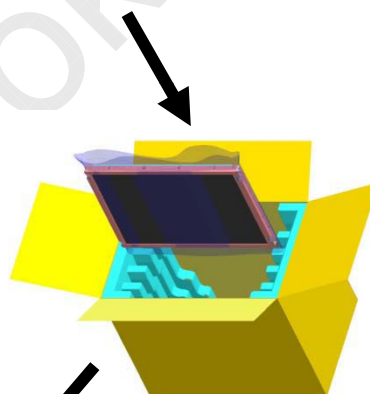

#### \* Notes

- Box Dimension: 333mm(W)X 333mm(D)X 435(H)
- Package Quantity in one Box: 10 pcs

SPEC. NUMBER S864-1435	SPEC TITLE HV150UX2-100 Product Specification for Customer	PAGE 25 OF 31
---------------------------	---	------------------

B2005-C001-A (2/3)

A4(210 X 297)

	<b>PRODUCT GROUP</b>	REV	ISSUE DATE
	TFT LCD PRODUCT	A	2011.08.17

### 14.2 Pallet Packing

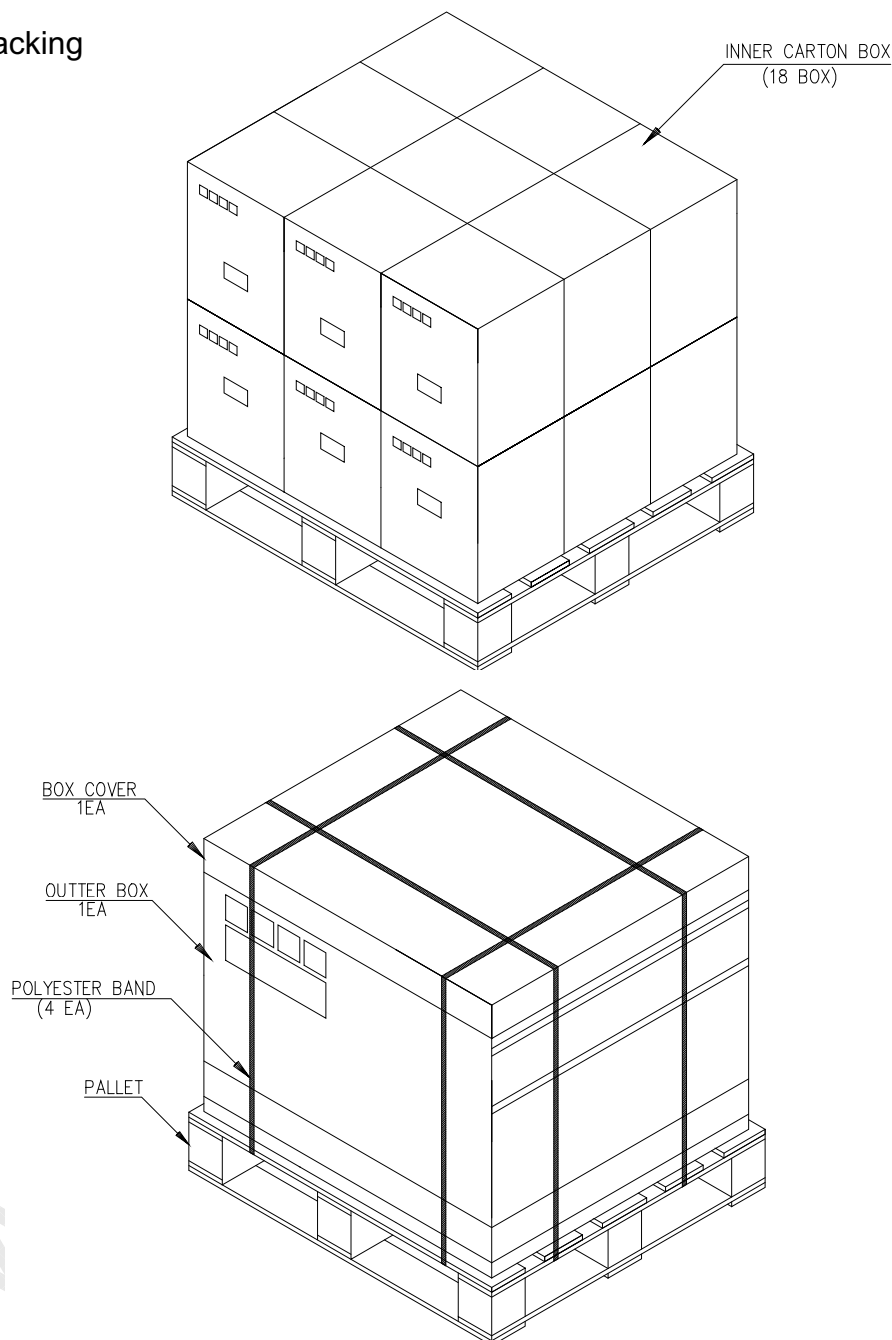

#### Note

- Pallet Dimension : : 1100 mm (L) × 1100 mm (W) × 120 mm (H)
- Package Quantity in one Box : 10pcs
- Box Quantity in one Pallet : 18box

SPEC. NUMBER S864-1435	SPEC TITLE HV150UX2-100 Product Specification for Customer	PAGE 26 OF 31
---------------------------	---	------------------

B2005-C001-A (2/3)

A4(210 X 297)

**HYDIS****PRODUCT GROUP**

REV

ISSUE DATE

TFT LCD PRODUCT

A

2011.08.17

**15.0 EDID data table**

Add (Hex)	Field name & comments	Data	Add (Hex)	Field name & Comments	Data
00	Header	00	1B	Red X : 0.569 (10010001)	91
01	Header	FF	1C	Red Y : 0.332 (01010100)	54
02	Header	FF	1D	Green X : 0.312 (01001111)	4F
03	Header	FF	1E	Green Y : 0.544 (100001011)	8B
04	Header	FF	1F	Blue X : 0.149 (00100110)	26
05	Header	FF	20	Blue Y : 0.132 (00100001)	21
06	Header	FF	21	White X : 0.313 (01010000)	50
07	Header	00	22	White Y : 0.329 (01010100)	54
08	ID System Manufacturer Name : LEN	30	23	Established timing I	21
09		AE	24	Established Timing II	08
0A	ID Product Code : UXGA FFS	46	25	Manufacturer's timings	00
0B		40	26	Standard timing ID1 (01h if not used)	81
0C	ID Serial number	00	27	Standard timing ID1 (01h if not used)	80
0D		00	28	Standard timing ID2 (01h if not used)	A9
0E		00	29	Standard timing ID2 (01h if not used)	40
0F		00	2A	Standard timing ID3 (01h if not used)	01
10	Week of manufacture	00	2B	Standard timing ID3 (01h if not used)	01
11	Year of Manufacturer : 2005	0F	2C	Standard timing ID4 (01h if not used)	01
12	EDID Structure version : Ver 1.0	01	2D	Standard timing ID4 (01h if not used)	01
13	EDID Revision Number : Rev 3	03	2E	Standard timing ID5 (01h if not used)	01
14	Digital I/P, Non TMDS CRGB	80	2F	Standard timing ID5 (01h if not used)	01
15	Max H image size (cm) : 30.45 cm	1E	30	Standard timing ID6 (01h if not used)	01
16	Max V image size (cm) : 22.8375 cm	16	31	Standard timing ID6 (01h if not used)	01
17	Display Gamma : 2.2	78	32	Standard timing ID7 (01h if not used)	01
18	Active off, RGB color	EA	33	Standard timing ID7 (01h if not used)	01
19	Red/Green low bits = 10111101	BD	34	Standard timing ID8 (01h if not used)	01
1A	Blue/White low bits = 00110000	30	35	Standard timing ID8 (01h if not used)	01

SPEC. NUMBER  
S864-1435SPEC TITLE  
HV150UX2-100 Product Specification for CustomerPAGE  
27 OF 31

B2005-C001-A (2/3)

A4(210 X 297)

 <b>HYDIS</b>	<b>PRODUCT GROUP</b>	REV	ISSUE DATE
	TFT LCD PRODUCT	A	2011.08.17

Add (Hex)	Field name & comments	Data	Add (Hex)	Field name & Comments	Data
36	Detailed timing descriptor #1	48	53	Hor Sync offset, PW : pulse width	00
37	Pixel clock (MHz) / 1000 : 162 MHz	3F	54	Horizontal image size (mm):304.5 mm	30
38	Horizontal active : 1600	40	55	Vertical image size (mm):228.375 mm	E4
39	Horizontal blanking : 560	30	56	Horizontal & Vertical image size : 0	10
3A	Horizontal active : blanking	62	57	Horizontal border : 0	00
3B	Vertical active : 1200	B0	58	Vertical border : 0	00
3C	Vertical blanking : 50	32	59	Flags : 0	19
3D	Vertical active : blanking	40	5A	Detailed timing descriptor #3	00
3E	Horizontal Sync offset : 64	40	5B	ASCII data string Tag (Supplier Name)	00
3F	Horizontal Sync pulse width : 192	C0	5C		00
40	Ver sync offset : pulse width = 1 : 3	13	5D		0F
41	Hor Sync offset, PW : pulse width	00	5E		00
42	Horizontal image size (mm):304.5 mm	30	5F	Horizontal active pixel / 8 - 31	A9
43	Vertical image size (mm):228.375 mm	E4	60	Image Aspect Rate (4:3)	43
44	Horizontal & Vertical image size : 0	10	61	Low refresh rate #1 (50 Hz)	32
45	Horizontal border : 0	00	62	Horizontal active pixel / 8 - 31	A9
46	Vertical border : 0	00	63	Image aspect rate (4:3)	43
47	Flags : 0	19	64	Low refresh rate #2 (40 Hz)	28
48	Detailed timing descriptor #2	BC	65	Brightness (1/10 nit)	14
49	Pixel clock (MHz) / 1000 : 135 MHz	34	66	Feature flag (FFS mode)	02
4A	Horizontal active : 1600	40	67	Reserved 00H	00
4B	Horizontal blanking : 560	30	68	EISA manufacturer code (3CharacterID)	09
4C	Horizontal active : blanking	62	69	Compressed ASCII	E5
4D	Vertical active : 1200	B0	6A	Panel supplier reserved -product code	00
4E	Vertical blanking : 50	32	6B	(Hex, LSB first)	00
4F	Vertical active : blanking	40	6C	Detailed timing descriptor #4	00
50	Horizontal Sync offset : 64	40	6D	ASCII data string Tag (Supplier P/N)	00
51	Horizontal Sync pulse width : 192	C0	6E		00
52	Ver sync offset : pulse width = 1 : 3	13	6F		FE

SPEC. NUMBER S864-1435	SPEC TITLE HV150UX2-100 Product Specification for Customer	PAGE 28 OF 31
---------------------------	---	------------------

B2005-C001-A (2/3)

A4(210 X 297)

 <b>HYDIS</b>	<b>PRODUCT GROUP</b>	REV	ISSUE DATE
	TFT LCD PRODUCT	A	2011.08.17

Add (Hex)	Field name & comments	Data	Add (Hex)	Field name & Comments	Data
70	ASCII data string Tag (Supplier P/N)	00	78	2	32
71	H	48	79	-	2D
72	V	56	7A	1	31
73	1	31	7B	0	30
74	5	35	7C	0	30
75	0	30	7D	SP (space)	0A
76	U	55	7E	Extension Flag	00
77	X	58	7F	Checksum	A6

SPEC. NUMBER S864-1435	SPEC TITLE HV150UX2-100 Product Specification for Customer	PAGE 29 OF 31
B2005-C001-A (2/3)		A4(210 X 297)

	<b>PRODUCT GROUP</b>	REV	ISSUE DATE
	TFT LCD PRODUCT	A	2011.08.17

**Figure 5. TFT-LCD Module Outline Dimension (Front View)**

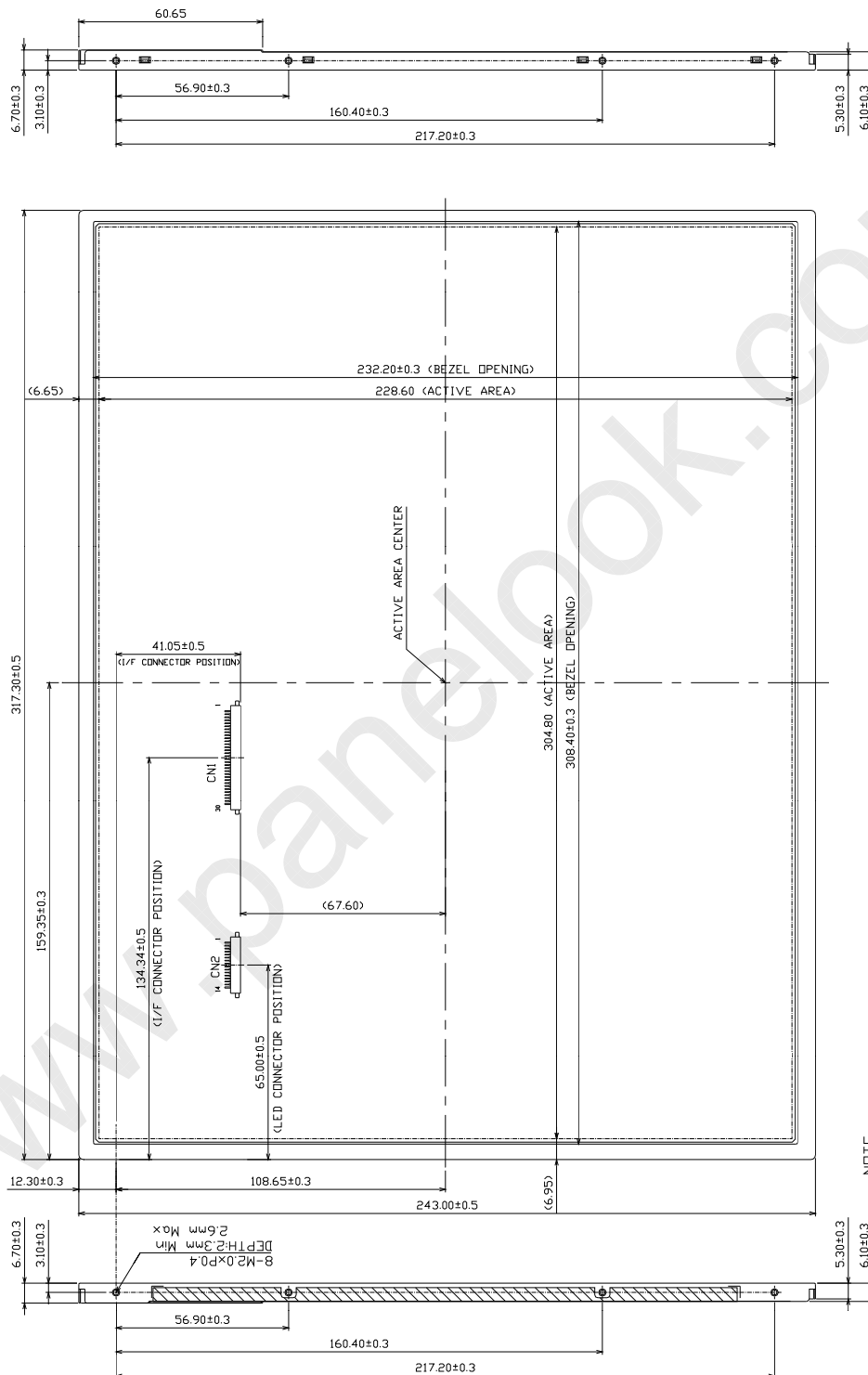

SPEC. NUMBER S864-1435	SPEC TITLE HV150UX2-100 Product Specification for Customer	PAGE 30 OF 31
---------------------------	---	------------------

B2005-C001-A (2/3)

A4(210 X 297)

	<b>PRODUCT GROUP</b>	REV	ISSUE DATE
	TFT LCD PRODUCT	A	2011.08.17

**Figure 6. TFT-LCD Module Outline Dimensions (Rear view)**

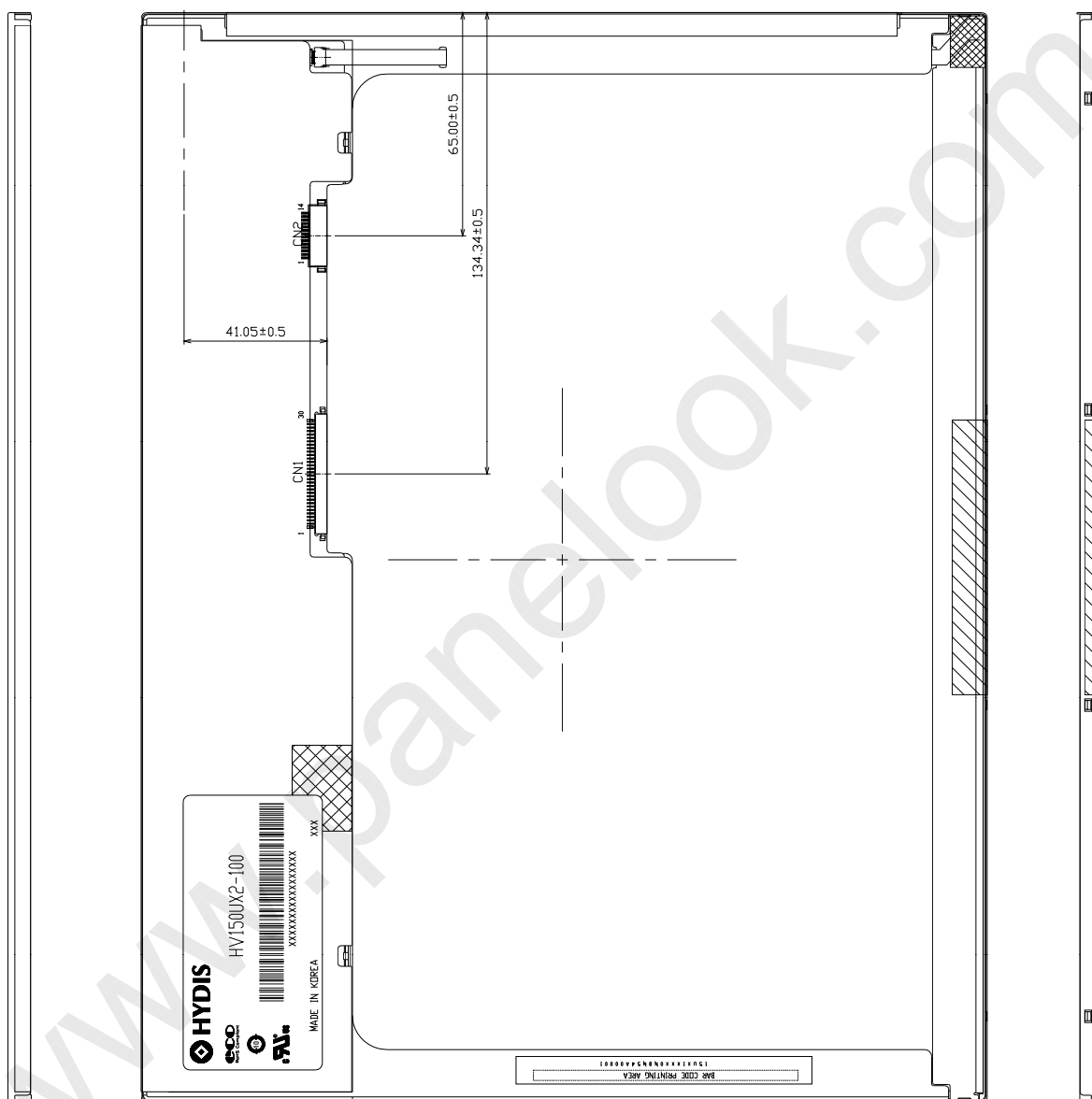

<b>SPEC. NUMBER</b> S864-1435	<b>SPEC TITLE</b> HV150UX2-100 Product Specification for Customer	<b>PAGE</b> 31 OF 31
----------------------------------	--	-------------------------