

SPEC. NUMBER
S863-8B012

PRODUCT GROUP
TFT-LCD

Rev. A

ISSUE DATE
2015.04.15

PAGE
1 OF 23

TITLE :

HV236WHB-N00 Product Specification

SPLCD.com
Supply & Purchase Cloud Platform



Hefei Xinsheng Optoelectronics Technology Co.,LTD.

Contents

No	ITEM	Page
	REVISIONS HISTORY	2
	CONTENTS	3
1	GENERAL DESCRIPTION	4
	1.1 Introduction	
	1.2 Features	
	1.3 Applications	
	1.4 General Specification	
2	ABSOLUTE MAXIMUM RATINGS	6
3	ELECTRICAL SPECIFICATIONS	7
	3.1 TFT LCD Open Cell	
4	INTERFACE CONNECTION	8
	4.1 Open Cell Input Signal & Power	
	4.2 LVDS Interface	
	4.3 LVDS Rx Interface Timing Parameter	
5	SIGNAL TIMING SPECIFICATIONS	11
	5.1 Timing Parameters	
	5.2 Signal Timing Waveform	
	5.3 Input Signals, Basic Display Colors & Cray Scale Of Colors	
	5.4 Power Sequence	
6	OPTICAL SPECIFICATIONS	15
7	MECHANICAL CHARACTERISTICS	17
8	RELIABILITY TEST CONDITION	18
9	PRODUCT SERIAL NUMBER	19
10	PACKING INFORMATION	20
11	HANDING & CAUTIONS	22
12	APPENDIX	23

1.0 GENERAL DESCRIPTION

1.1 Introduction

HV236WHB-N00 is a color active matrix TFT LCD open cell using amorphous silicon TFT's (Thin Film Transistors) as an active switching devices. This open cell has a 23.6 inch diagonally measured active area with WXGA resolutions (1366 horizontal by 768 vertical pixel array). Each pixel is divided into RED, GREEN, BLUE dots which are arranged in vertical stripe and this open cell can display 16.7M colors. The TFT-LCD panel used for this open cell is adapted for a low reflection and higher color type.

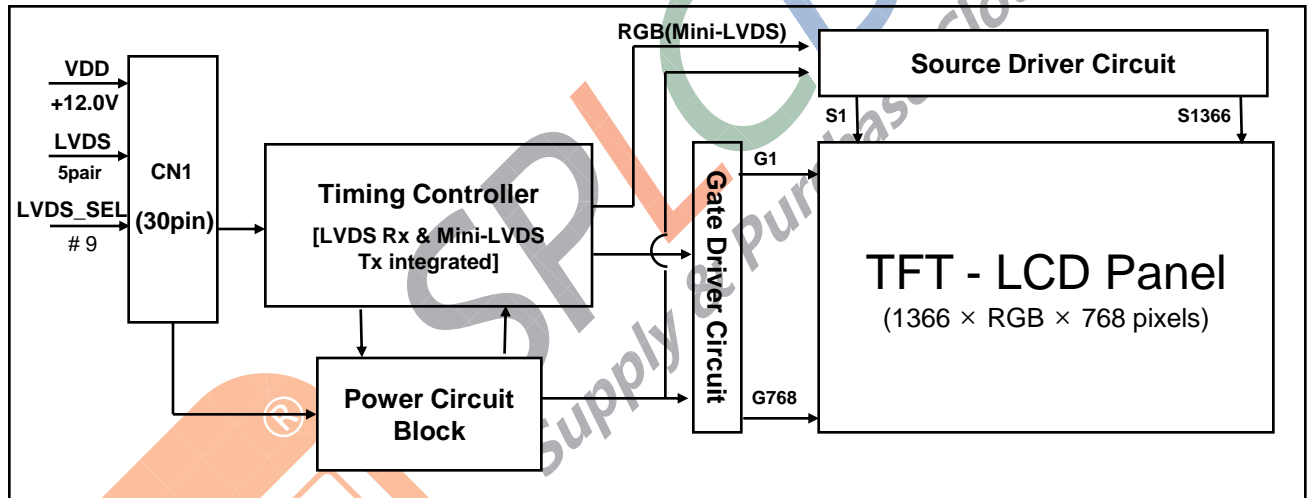

1.2 Features

- LVDS interface with 1 pixel / clock
- Low color shift image quality
- display 16.7M colors(6Bits + FRC)
- High luminance and contrast ratio, low reflection and wide viewing angle
- DE (Data Enable) only mode
- ADS technology is applied for high display quality
- RoHS compliant
- 0.5t Glass

1.3 Application

- Home Alone Multimedia TFT-LCD TV
- Display Terminals for Control System
- High Definition TV(HD TV)
- AV application Products

1.4 General Specification

< Table 1. General Specifications >

Parameter	Specification	Unit	Remark
Active area	521.471(H) × 293.184(V)	mm	
Number of pixels	1366(H) × 768(V)	pixels	
Pixel pitch	381.75(H) × RGB × 381.75(V)	μm	
Pixel arrangement	Pixels RGB Vertical stripe		
Display colors	16.7M(6bits+FRC)	colors	
Display mode	Transmission mode, Normally Black		
Open Cell Transmittance	5.8 (typ.)	%	At center point with BOE BLU
Weight	471 (typ.)	gram	
Power Consumption	4 (typ.)	Watt	
Surface Treatment	Haze 1%, 3H, treatment (Front Polarizer) Clear (Bottom Polarizer)		

2.0 ABSOLUTE MAXIMUM RATINGS

The followings are maximum values which, if exceed, may cause faulty operation or damage to the unit. The operational and non-operational maximum voltage and current values are listed in Table 2.

< Table 2. Open Cell Electrical Specifications >

[VSS=GND=0V]

Parameter	Symbol	Min.	Max.	Unit	Remark
Power Supply Voltage	VDD	VSS-0.3	13.2	V	Ta = 25 °C
Operating Temperature	T _{OP}	0	+50	°C	Note 1
	T _{SUR}	0	+60	°C	
Storage Temperature	T _{ST}	-20	+60	°C	
Operating Ambient Humidity	H _{op}	10	90	%RH	
Storage Humidity	H _{st}	10	90	%RH	

Note 1 : Temperature and relative humidity range are shown in the figure below.
Wet bulb temperature should be 39 °C max. and no condensation of water.

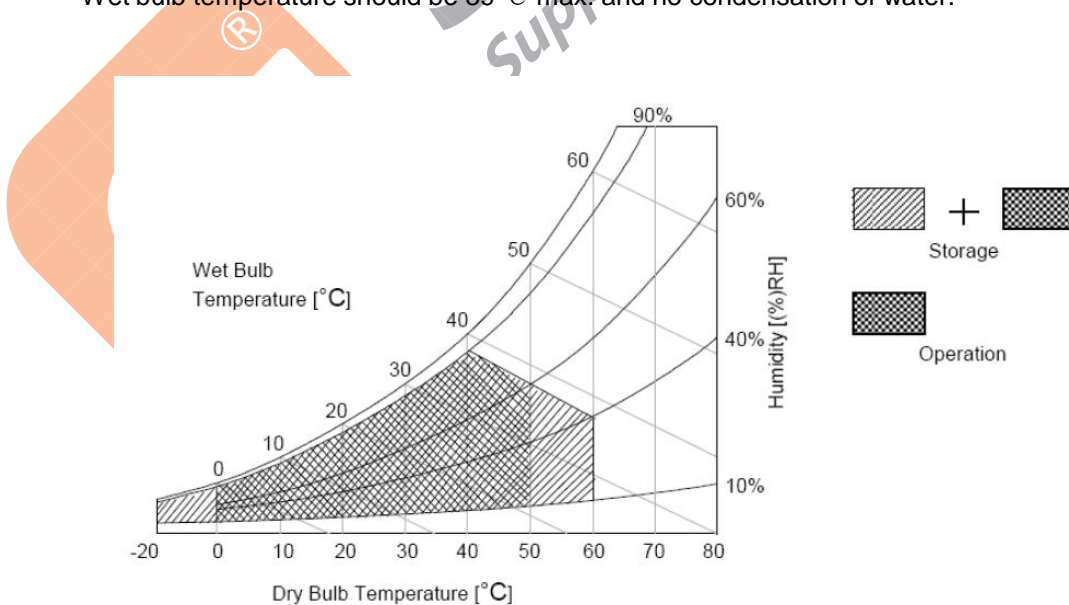

3.0 ELECTRICAL SPECIFICATIONS

3.1 TFT LCD Open Cell

< Table 3. Open Cell Electrical Specifications >

[Ta = 25 ± 2 °C]

Parameter		Symbol	Values			Unit	Remark
			Min	Typ	Max		
Power Supply Input Voltage		VDD	10.8	12	13.2	Vdc	
Power Supply Ripple Voltage		VRP			300	mV	
Power Supply Current		IDD	-	333	-	mA	Note 1
Power Consumption		PDD	-	4.0	7.1	Watt	
Rush current		IRUSH	-		4	A	Note 2
LVDS Interface	Differential Input High Threshold Voltage	VLVTH	+100		+300	mV	
	Differential Input Low Threshold Voltage	VLVTL	-300		-100	mV	
	Common Input Voltage	VLVC	1.0	1.2	1.4	V	
CMOS Interface	Input High Threshold Voltage	VIH	2.7	-	3.3	V	
	Input Low Threshold Voltage	VIL	0	-	0.6	V	

Note 1 : The supply voltage is measured and specified at the interface connector of LCM.

The current draw and power consumption specified is for VDD=12.0V,

Frame rate $f_v=60\text{Hz}$ and Clock frequency = 75.4MHz.

Note 2 : Test Pattern of power supply current & Flicker test Pattern

a) Typ : Mosaic 8 x 6 Pattern(L0/L255)

b) Max : Skip 1H2V Sub Dot

c) Flicker test Pattern
Pattern(L0/Green127)

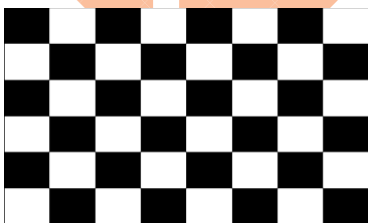

(a)



(b)

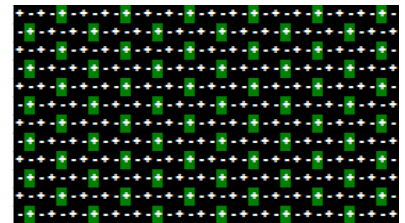

(c)

Note 3 : The duration of rush current is about 2ms and rising time of Power Input is 1ms(min)

4.0 INTERFACE CONNECTION

4.1 Open Cell Input Signal & Power

- Connector : IS100-L30B-C23(Manufactured by UJU) or Equivalent.

< Table 4. Open Cell Input Connector Pin Configuration >

Pin No	Symbol	Description	Pin No	Symbol	Description
1	VDD	Power Supply +12.0V	16	RX1+	LVDS Receiver Signal(+)
2	VDD	Power Supply +12.0V	17	GND	Ground
3	VDD	Power Supply +12.0V	18	RX2-	LVDS Receiver Signal(-)
4	VDD	Power Supply +12.0V	19	RX2+	LVDS Receiver Signal(+)
5	GND	Ground	20	GND	Ground
6	GND	Ground	21	RCLK-	LVDS Receiver Clock Signal(-)
7	GND	Ground	22	RCLK+	LVDS Receiver Clock Signal(+)
8	NC	No Connection	23	GND	Ground
9	LVDS_SEL	'H' or NC=JEIDA , 'L' = VESA	24	RX3-	LVDS Receiver Signal(-)
10	NC	No Connection	25	RX3+	LVDS Receiver Signal(+)
11	GND	Ground	26	GND	Ground
12	RX0-	LVDS Receiver Signal(-)	27	NC	No Connection
13	RX0+	LVDS Receiver Signal(+)	28	SDA	I2C Data (For Vcom tuning)
14	GND	Ground	29	SCL	I2C clock (For Vcom tuning)
15	RX1-	LVDS Receiver Signal(-)	30	GND	Ground

Notes : 1. NC(Not Connected) : This pins are only used for BOE internal operations.

2. Input Level of LVDS signal is based on the IEA 664 Standard.

3. LVDS_SEL : This pin is used for selecting LVDS signal data format.

If this Pin : High (3.3V) or Open (NC) → Normal JEIDA LVDS format

Otherwise : Low (GND) → VESA LVDS format

Rear view of LCM

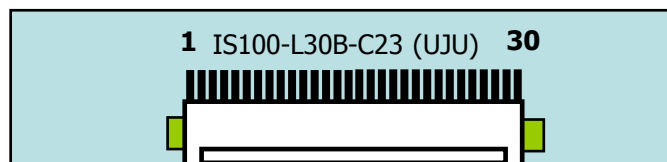

4.2 LVDS Interface

- LVDS Receiver : Timing Controller (LVDS Rx merged) / LVDS Data : Pixel Data
< Table 5. Open Cell Input Connector Pin Configuration >

	LVDS Pin	Vesa Data format	JEIDA Data format	Remark
TxOUT/RxIN0	TxIN/RxOUT0	Red0 [LSB]	R2	
	TxIN/RxOUT1	Red1	R3	
	TxIN/RxOUT2	Red2	R4	
	TxIN/RxOUT3	Red3	R5	
	TxIN/RxOUT4	Red4	R6	
	TxIN/RxOUT6	Red5	R7 [MSB]	
	TxIN/RxOUT7	Green0 [LSB]	G2	
TxOUT/RxIN1	TxIN/RxOUT8	Green1	G3	
	TxIN/RxOUT9	Green2	G4	
	TxIN/RxOUT12	Green3	G5	
	TxIN/RxOUT13	Green4	G6	
	TxIN/RxOUT14	Green5	G7 [MSB]	
	TxIN/RxOUT15	Blue0 [LSB]	B2	
	TxIN/RxOUT18	Blue1	B3	
TxOUT/RxIN2	TxIN/RxOUT19	Blue2	B4	
	TxIN/RxOUT20	Blue3	B5	
	TxIN/RxOUT21	Blue4	B6	
	TxIN/RxOUT22	Blue5	B7 [MSB]	
	TxIN/RxOUT24	HSYNC	HSYNC	
	TxIN/RxOUT25	VSYNC	VSYNC	
	TxIN/RxOUT26	DEN	DEN	
TxOUT/RxIN3	TxIN/RxOUT27	Red6	R0 [LSB]	
	TxIN/RxOUT5	Red7 [MSB]	R1	
	TxIN/RxOUT10	Green6	G0 [LSB]	
	TxIN/RxOUT11	Green7 [MSB]	G1	
	TxIN/RxOUT16	Blue6	B0 [LSB]	
	TxIN/RxOUT17	Blue7 [MSB]	B1	
	TxIN/RxOUT23	Reserved	Reserved	

4.3 LVDS Rx Interface Timing Parameter

The Specification of the LVDS Rx interface timing parameter is shown in Table6

< Table 6. LVDS Rx Interface Timing Specification >

Item	Symbol	Min	Typ	Max	Unit	Note
CLKIN Period	T	9.1	20	40	nsec	
Input Data0	tRCIP1	0.5T/7-0.4	0.5T/7	0.5T/7+0.4	nsec	
Input Data1	tRCIP0	1.5T/7-0.4	1.5T/7	1.5T/7+0.4	nsec	
Input Data2	tRCIP6	2.5T/7-0.4	2.5T/7	2.5T/7+0.4	nsec	
Input Data3	tRCIP5	3.5T/7-0.4	3.5T/7	3.5T/7+0.4	nsec	
Input Data4	tRCIP4	4.5T/7-0.4	4.5T/7	4.5T/7+0.4	nsec	
Input Data5	tRCIP3	5.5T/7-0.4	5.5T/7	5.5T/7+0.4	nsec	
Input Data6	tRCIP2	6.5T/7-0.4	6.5T/7	6.5T/7+0.4	Nsec\	

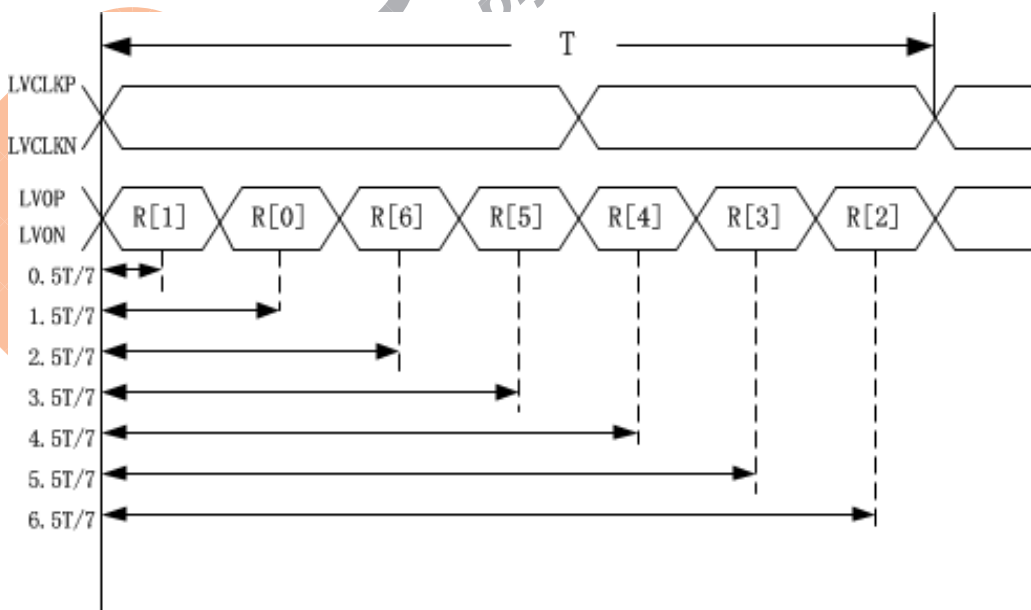

Notes: Input frequency range from 25MHz to 110MHz

5.0 SIGNAL TIMING SPECIFICATION

5.1 Timing Parameters (DE only mode)

< Table 7. Timing Table >

ITEM	Symbol		Min	Typ	Max	Unit	Note
CLK	Period	t_{CLK}	11.8	13.3	17.9	ns	
	Frequency	-	25	75.4	110	MHz	
Hsync	Period	t_{HP}	1450	1560	2000	t_{CLK}	
	Frequency	f_H	39.4	48.4	55	KHz	
Vsync	Period	t_{VP}	778	806	1200	t_{HP}	
	Frequency	f_V	47	60	65	Hz	
Horizontal Active Display Term	Valid	t_{HV}	-	1366	-	t_{CLK}	
	Total	t_{HP}	1450	1560	2000	t_{CLK}	
Vertical Active Display Term	Valid	t_{VV}	-	768	-	t_{HP}	
	Total	t_{VP}	778	806	1200	t_{HP}	

Notes: This product is DE only mode. The input of Hsync & Vsync signal does not have an effect on normal operation.

< Table 8. LVDS Input SSC >

Symbol	Parameter	Condition	Min	Typ	Max	Unit
F	LVDS Input frequency	-	25	50	110	MHz
T_{LVSK}	LVDS channel to channel skew	F=65MHz $V_{IC}=1.2V$ $V_{ID}=\pm 200mV$	-600	-	+600	ps
F_{LVMOD}	Modulating frequency of input clock during SSC	F=85MHz $V_{IC}=1.2V$ $V_{ID}=\pm 200mV$	10	-	300	KHz
F_{LVDEV}	Maximum deviation of input clock frequency during SSC		-3	-	+3	%
T_{CY-CY}	Cycle to Cycle jitter		-	-	200	ps

5.2 Signal Timing Waveform

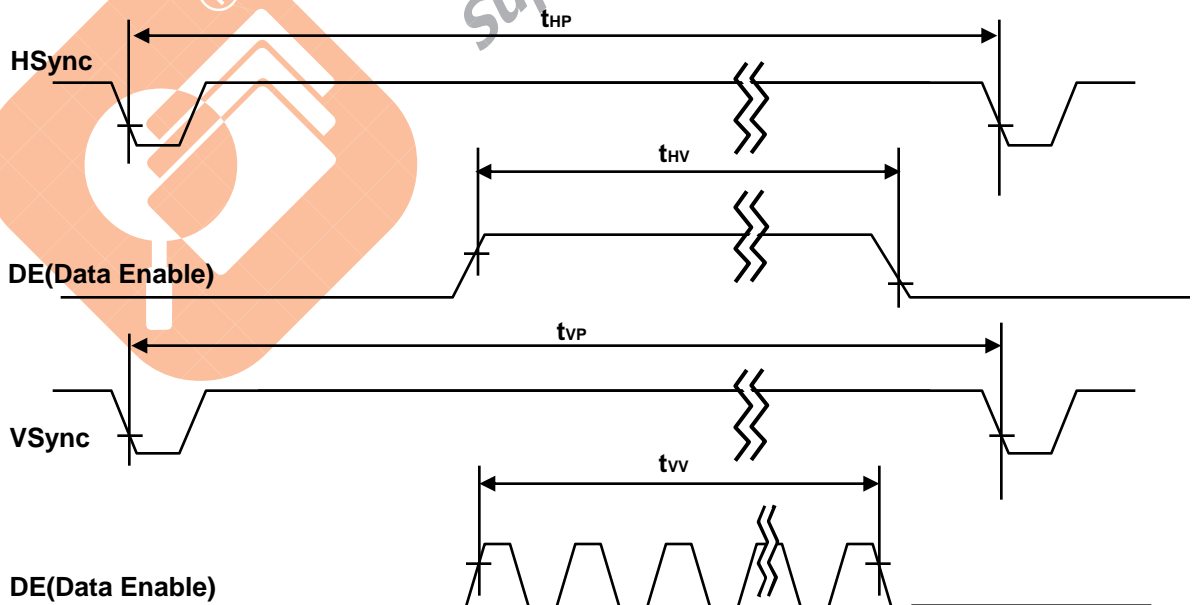
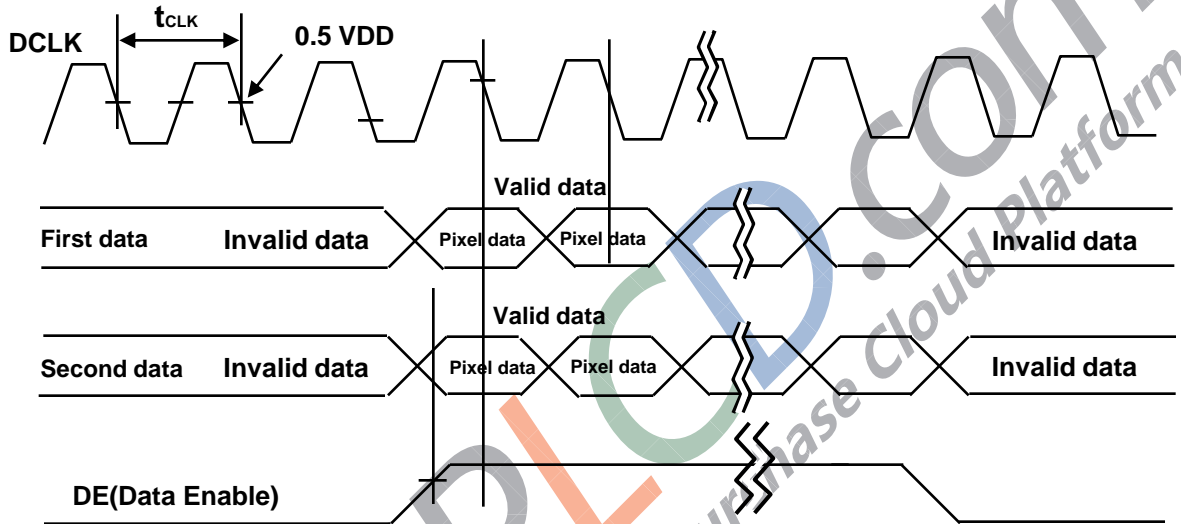

5.3 Input Signals, Basic Display Colors and Gray Scale of Colors

< Table 9. Input Signal and Display Color Table >

Color & Gray Scale		Input Data Signal																							
		Red Data								Green Data						Blue Data									
		R7	R6	R5	R4	R3	R2	R1	R0	G7	G6	G5	G4	G3	G2	G1	G0	B7	B6	B5	B4	B3	B2	B1	B0
Basic Colors	Black	0	0	0	0	0	0	0	0	0	0	0	0	0	0	0	0	0	0	0	0	0	0	0	0
	Blue	0	0	0	0	0	0	0	0	0	0	0	0	0	0	0	0	1	1	1	1	1	1	1	1
	Green	0	0	0	0	0	0	0	0	1	1	1	1	1	1	1	1	0	0	0	0	0	0	0	0
	Cyan	0	0	0	0	0	0	0	0	1	1	1	1	1	1	1	1	1	1	1	1	1	1	1	1
	Red	1	1	1	1	1	1	1	1	0	0	0	0	0	0	0	0	0	0	0	0	0	0	0	0
	Magenta	1	1	1	1	1	1	1	1	0	0	0	0	0	0	0	0	1	1	1	1	1	1	1	1
	Yellow	1	1	1	1	1	1	1	1	1	1	1	1	1	1	1	1	0	0	0	0	0	0	0	0
	White	1	1	1	1	1	1	1	1	1	1	1	1	1	1	1	1	1	1	1	1	1	1	1	1
Gray Scale of Red	Black	0	0	0	0	0	0	0	0	0	0	0	0	0	0	0	0	0	0	0	0	0	0	0	
	△	0	0	0	0	0	0	0	1	0	0	0	0	0	0	0	0	0	0	0	0	0	0	0	
	Darker	0	0	0	0	0	0	1	0	0	0	0	0	0	0	0	0	0	0	0	0	0	0	0	
	△																								
	▽																								
	Brighter	1	1	1	1	1	1	0	1	0	0	0	0	0	0	0	0	0	0	0	0	0	0	0	
	▽	1	1	1	1	1	1	1	0	0	0	0	0	0	0	0	0	0	0	0	0	0	0	0	
	Red	1	1	1	1	1	1	1	1	0	0	0	0	0	0	0	0	0	0	0	0	0	0	0	0
Gray Scale of Green	Black	0	0	0	0	0	0	0	0	0	0	0	0	0	0	0	0	0	0	0	0	0	0	0	
	△	0	0	0	0	0	0	0	0	0	0	0	0	0	0	0	1	0	0	0	0	0	0	0	
	Darker	0	0	0	0	0	0	0	0	0	0	0	0	0	0	1	0	0	0	0	0	0	0	0	
	△																								
	▽																								
	Brighter	0	0	0	0	0	0	0	0	1	1	1	1	1	1	0	1	0	0	0	0	0	0	0	
	▽	0	0	0	0	0	0	0	0	1	1	1	1	1	1	0	0	0	0	0	0	0	0	0	
	Green	0	0	0	0	0	0	0	0	1	1	1	1	1	1	1	1	0	0	0	0	0	0	0	
Gray Scale of Blue	Black	0	0	0	0	0	0	0	0	0	0	0	0	0	0	0	0	0	0	0	0	0	0	0	
	△	0	0	0	0	0	0	0	0	0	0	0	0	0	0	0	0	0	0	0	0	0	0	1	
	Darker	0	0	0	0	0	0	0	0	0	0	0	0	0	0	0	0	0	0	0	0	0	0	1	
	△																								
	▽																								
	Brighter	0	0	0	0	0	0	0	0	0	0	0	0	0	0	0	1	1	1	1	1	1	1	0	
	▽	0	0	0	0	0	0	0	0	0	0	0	0	0	0	0	1	1	1	1	1	1	1	0	
	Blue	0	0	0	0	0	0	0	0	0	0	0	0	0	0	0	1	1	1	1	1	1	1	1	
Gray Scale of White	Black	0	0	0	0	0	0	0	0	0	0	0	0	0	0	0	0	0	0	0	0	0	0	0	
	△	0	0	0	0	0	0	0	1	0	0	0	0	0	0	0	1	0	0	0	0	0	0	1	
	Darker	0	0	0	0	0	0	1	0	0	0	0	0	0	0	1	0	0	0	0	0	0	0	1	
	△																								
	▽																								
	Brighter	1	1	1	1	1	1	0	1	1	1	1	1	1	0	1	1	1	1	1	1	1	0	1	
	▽	1	1	1	1	1	1	1	0	1	1	1	1	1	1	0	1	1	1	1	1	1	1	0	
	White	1	1	1	1	1	1	1	1	1	1	1	1	1	1	1	1	1	1	1	1	1	1	1	

5.4 Power Sequence

To prevent a latch-up or DC operation of the Open Cell, the power on/off sequence shall be as shown in below

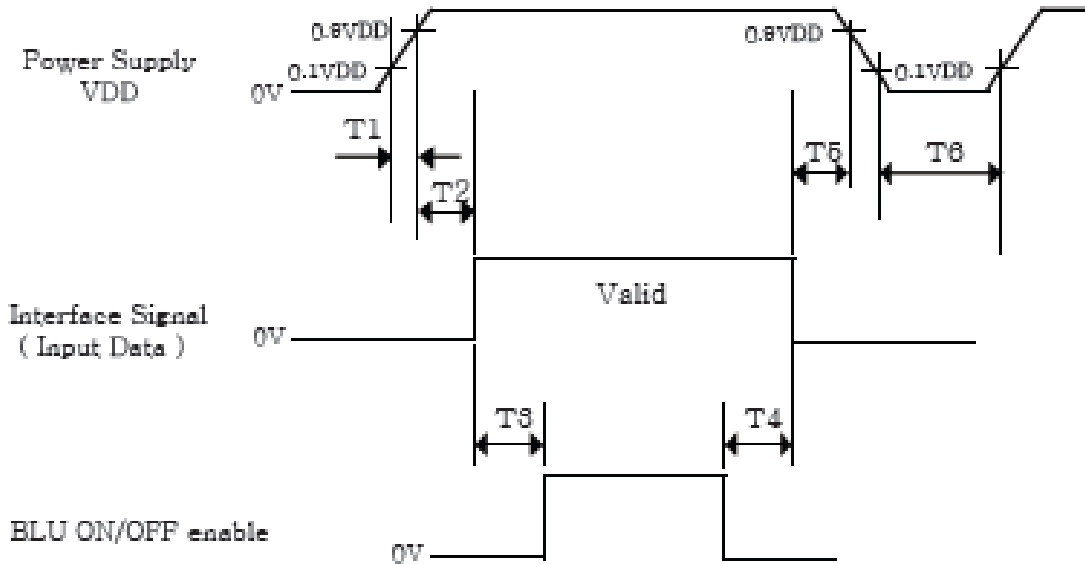

< Table 10. Sequence Table >

Parameter	Values			Units
	Min	Typ	Max	
T1	0.5	-	20	ms
T2	0	-	50	ms
T3	200	-	-	ms
T4	200	-	-	ms
T5	0	-	50	ms
T6	1	-	-	s

- Notes: 1. Even though T1 is over the specified value, there is no problem if I2T spec of fuse is satisfied.
2. Back Light must be turn on after power for logic and interface signal are valid.

6.0 OPTICAL SPECIFICATIONS

The test of optical specifications shall be measured in a dark room (ambient luminance ≤ 1 lux and temperature $= 25 \pm 2^\circ\text{C}$) with the equipment of Luminance meter system (Goniometer system and PR730) and test unit shall be located at an approximate distance 50cm from the LCD surface at a viewing angle of θ and Φ equal to 0° . We refer to $\theta_{\Phi=0}$ ($=\theta_3$) as the 3 o'clock direction (the "right"), $\theta_{\Phi=90}$ ($=\theta_{12}$) as the 12 o'clock direction ("upward"), $\theta_{\Phi=180}$ ($=\theta_9$) as the 9 o'clock direction ("left") and $\theta_{\Phi=270}$ ($=\theta_6$) as the 6 o'clock direction ("bottom"). While scanning θ and/or Φ , the center of the measuring spot on the Display surface shall stay fixed. The measurement shall be executed after 30 minutes warm-up period. VDD shall be 12.0V $\pm 10\%$ at 25°C . Optimum viewing angle direction is 6 'clock.

< Table 11. Optical Table >

[VDD = 12.0V, Frame rate = 60Hz, Ta = $25 \pm 2^\circ\text{C}$]

Parameter		Symbol	Condition	Min	Typ	Max	Unit	Remark
Viewing Angle	Horizontal	Θ_3	CR > 10		89		Deg.	Note 1
		Θ_9			89			
	Vertical	Θ_{12}			89			
		Θ_6			89			
Contrast ratio		CR		700:1	1000:1	-		Note 2
Reproduction of color	White	W_x	$\Theta = 0^\circ$ (Center) Normal Viewing Angle With BOE Module	TYP. - 0.03	0.280	TYP. + 0.03		Note 3
		W_y			0.290			
	Red	R_x			0.625			
		R_y			0.340			
	Green	G_x			0.292			
		G_y			0.597			
	Blue	B_x			0.153			
		B_y			0.095			
Response Time	G to G	T_g		-	14	-	ms	Note 4
Gamma Scale				2.0	2.2	2.4		
Cell Transmittance					5.8		%	Note 5

Note :

1. Viewing angle is the angle at which the contrast ratio is greater than 10. The viewing are determined for the horizontal or 3, 9 o'clock direction and the vertical or 6, 12 o'clock direction with respect to the optical axis which is normal to the LCD surface.
2. Contrast measurements shall be made at viewing angle of $\theta = 0^\circ$ and at the center of the LCD surface. Luminance shall be measured with all pixels in the view field set first to white, then to the dark (black) state. (See Figure 1 shown in Appendix) Luminance Contrast Ratio (CR) is defined mathematically.

$$CR = \frac{\text{Luminance when displaying a white raster}}{\text{Luminance when displaying a black raster}}$$

3. The color chromaticity coordinates specified in Table 9. shall be calculated from the spectral data measured with all pixels first in red, green, blue and white. Measurements shall be made at the center of the panel at BOE BLU.
4. Response time T_g is the average time required for display transition by switching the input signal as below table and is based on Frame rate $f_V = 60\text{Hz}$ to optimize. Each time in below table is defined as Figure 2 and shall be measured by switching the input signal for "any level of gray(bright)" and "any level of gray(dark)".

Measured Response Time	Target																
	0	15	31	47	63	79	95	111	127	143	159	175	191	207	223	239	255
0																	
15																	
31																	
47																	
63																	
79																	
95																	
111																	
127																	
143																	
159																	
175																	
191																	
207																	
223																	
239																	
255																	

5. Definition of Transmittance (T%) :

Module is with white(L255) signal input

$$\text{Transmittance} = \frac{\text{Luminance of LCD Module}}{\text{Luminance of BLU}} \times 100 \%$$

7.0 MECHANICAL CHARACTERISTICS

7.1 Dimensional Requirements

Figure 3 (located in Appendix) shows mechanical outlines for the model HV236WHB-N00. Other parameters are shown in Table 10.

< Table 12. Dimensional Parameters >

Parameter	Specification	Unit
Active area	521.471(H) × 293.184(V)	mm
Pixel pitch	0.382(H) × 0.382(V)	mm
Number of pixels	1366(H) × 768(V) (1 pixel = R + G + B dots)	pixels
Weight	471(typ.)	gram

7.2 Anti-Glare and Polarizer Hardness

The surface of the LCD has an Anti-glare coating to minimize reflection and a coating to reduce scratching.



8.0 Reliability Test Condition

< Table 13. Reliability Test Condition >

Item	Test Condition
High-Temp/STG	Ta = 60 °C, 240 hrs
Low-Temp/STG	Ta = -20 °C, 240 hrs
High-Temp/HMD	Ta = 50 °C, 80%RH, 240hrs
High-Temp/OP	Ta = 50 °C, 240hrs
Low-Temp/OP	Ta = -5 °C, 240hrs
TST	Ta = -20 °C ↔ 60 °C (per0,5 hr), 100 cycle

This test condition is based on BOE module.



9.0 PRODCUT SERIAL NUMBER



MDL ID Naming Rule:

Code \ Digit	1	2	3	4	5	6	7	8	9	10	11	12	13
Code	S	L	S	5	1	2	3	5	9	0	0	0	0
Description	Model Code /GBN		Grade	Line	Year		Month	Model Extension Code		SerialNo 00001-ZZZZZZ			



10.0 PACKING INFORMATION

BOE provides the standard shipping container for customers, unless customer specifies their packing information. The standard packing method and Barcode information are shown in below.

10.1 Packing Order

Put EPE pad and panels into the box, 17pcs panels per box

Put the box on the pallet, 8ea boxes per quarter pallet, a cover on the top of the boxes

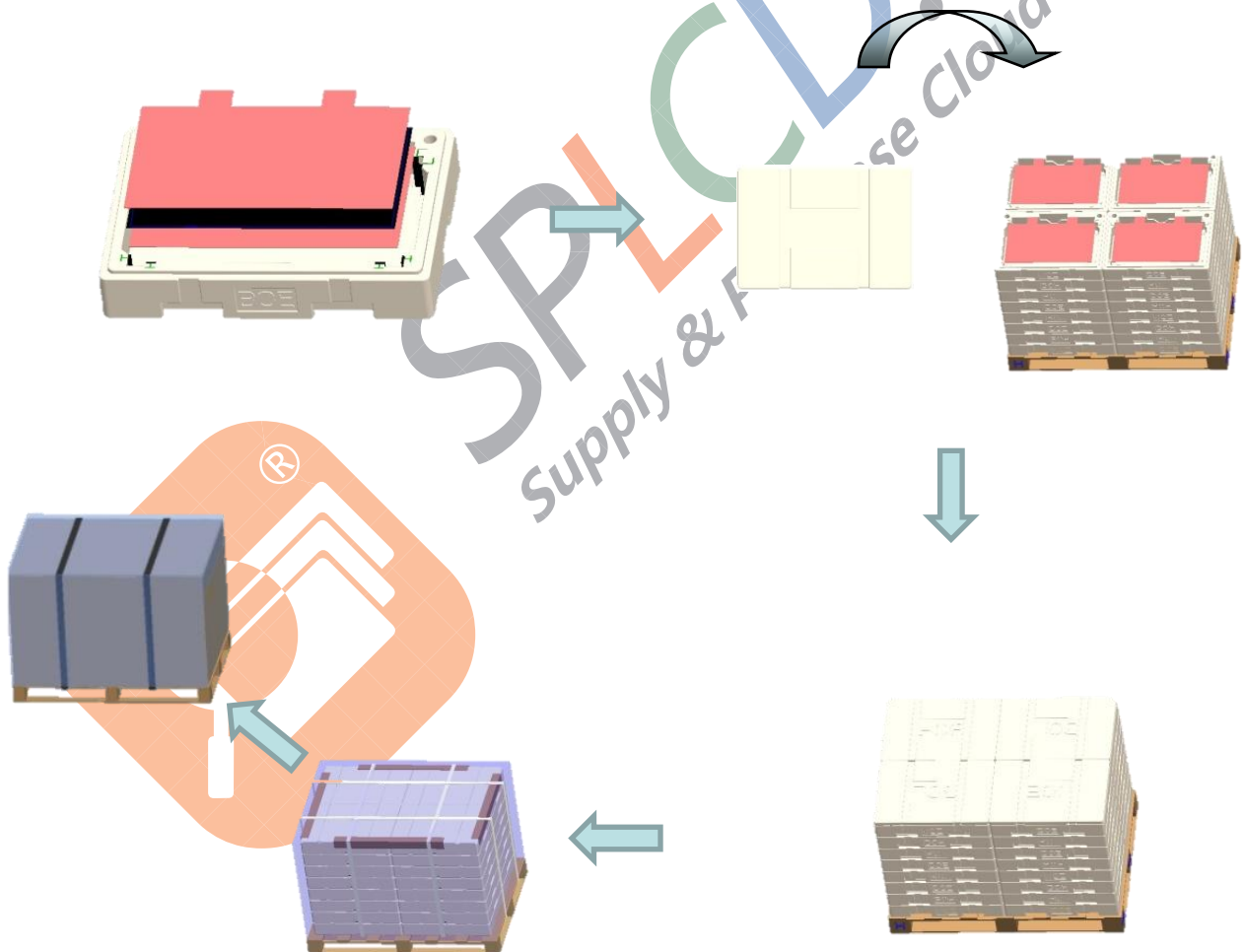

Pack with paper corner & belt, then use wrapping film & out box to bind up them

32ea boxes and 4 covers per pallet

10.2 Packing Note

- Box Dimension : 660mm(L)×460mm(W)×113mm(G)
- Package Quantity in one Box : 17pcs

10.3 Box Label

- Label Size : 110 mm (L) × 55 mm (W)
- Contents

Model : HV236WHB-N00

Q`ty : 17pcs Open Cell in one box.

Serial No. : Box Serial No.

Date : Packing Date

FG Code : FG Code of Product



Box ID Naming Rule:

Digit	1	2	3	4	5	6	7	8	9	10	11	12	13
Code	S	L	S	5	1	2	3	D	0	0	0	6	8
Description	Products GBN		Grade	Line	Year		Month	Revision Code	Serial No				

11.0 HANDLING & CAUTIONS

- (1) Cautions when taking out the Panel
 - Pick the pouch only, when taking out panel from a shipping package.
- (2) Cautions for handling the panel
 - As the electrostatic discharges may break the LCD panel, handle the LCD panel with care. Peel a protection sheet off from the LCD panel surface as slowly as possible.
 - As the LCD panel and back - light element are made from fragile glass material, impulse and pressure to the LCD panel should be avoided.
 - As the surface of the polarizer is very soft and easily scratched, use a soft dry cloth without chemicals for cleaning.
 - Do not pull the interface connector in or out while the LCD panel is operating.
 - Put the panel display side down on a flat horizontal plane.
 - Handle connectors and cables with care.
- (3) Cautions for the operation
 - When the panel is operating, do not lose CLK, ENAB signals. If any one of these signals is lost, the LCD panel would be damaged.
 - Obey the supply voltage sequence. If wrong sequence is applied, the panel would be damaged.
- (4) Cautions for the atmosphere
 - Dew drop atmosphere should be avoided.
 - Do not store and/or operate the LCD panel in a high temperature and/or humidity atmosphere. Storage in an electro-conductive polymer packing pouch and under relatively low temperature atmosphere is recommended.
- (5) Cautions for the panel characteristics
 - Do not apply fixed pattern data signal to the LCD panel at product aging.
 - Applying fixed pattern for a long time may cause image sticking.
- (6) Other cautions
 - Do not disassemble and/or re-assemble LCD panel.
 - Do not re-adjust variable resistor or switch etc.
 - When returning the panel for repair or etc., Please pack the panel not to be broken. We recommend to use the original shipping packages.

12.0 APPENDIX

< Figure 1. Measurement Set Up >

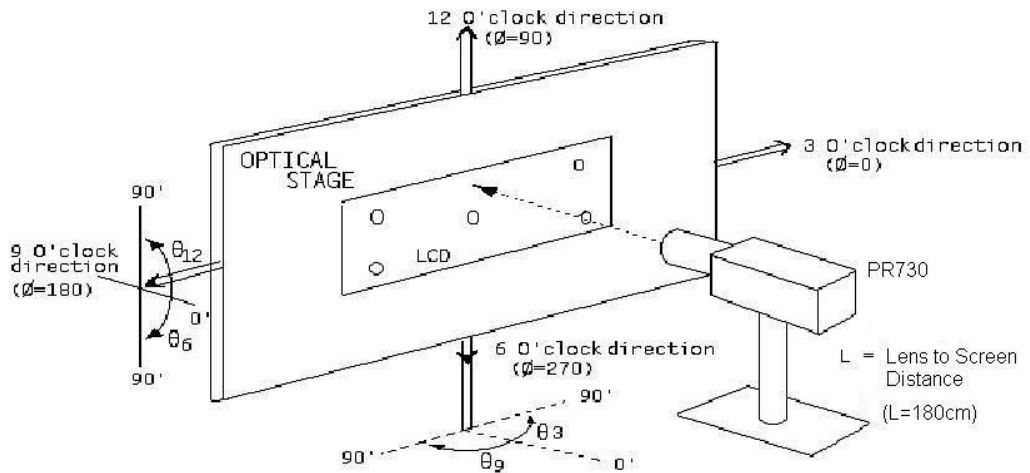

< Figure 2. Response Time Testing >

