

## Quad, High Voltage, Amplifier Array

### Features

- ▶ Four independent high voltage amplifiers
- ▶ 190V output swing
- ▶ 9.0V/ $\mu$ s typical output slew rate
- ▶ Fixed gain of 66.7V/V
- ▶ High value internal feedback resistors
- ▶ Very low operating current

### Applications

- ▶ Tunable Laser
- ▶ MEMS driver
- ▶ Test equipment
- ▶ Piezoelectric transducer driver
- ▶ Braille driver

### General Description

The Supertex HV264 is a quad high voltage amplifier array integrated circuit. It operates on a 200V high voltage supply and a 5.0V low voltage supply. Each channel has its own input and output.

When both VOUT and FB pins are connected together and RGND is set at 0V, a non-inverting amplifier is formed with closed loop gain of 66.7V/V. High value internal feedback resistors are used to minimize the power dissipation. The input voltage  $V_{IN}$  is designed for a range of 0.05V to 2.85V. The output can swing from 1.0V to  $V_{PP} - 10V$ . A 2.85V input will cause the output to swing to 190V.

The HV264 is designed for maximum performance with minimal high voltage current. The high voltage current for each channel is less than 75 $\mu$ A. The typical output slew rate performance is 9.0V/ $\mu$ s.

### Block Diagram

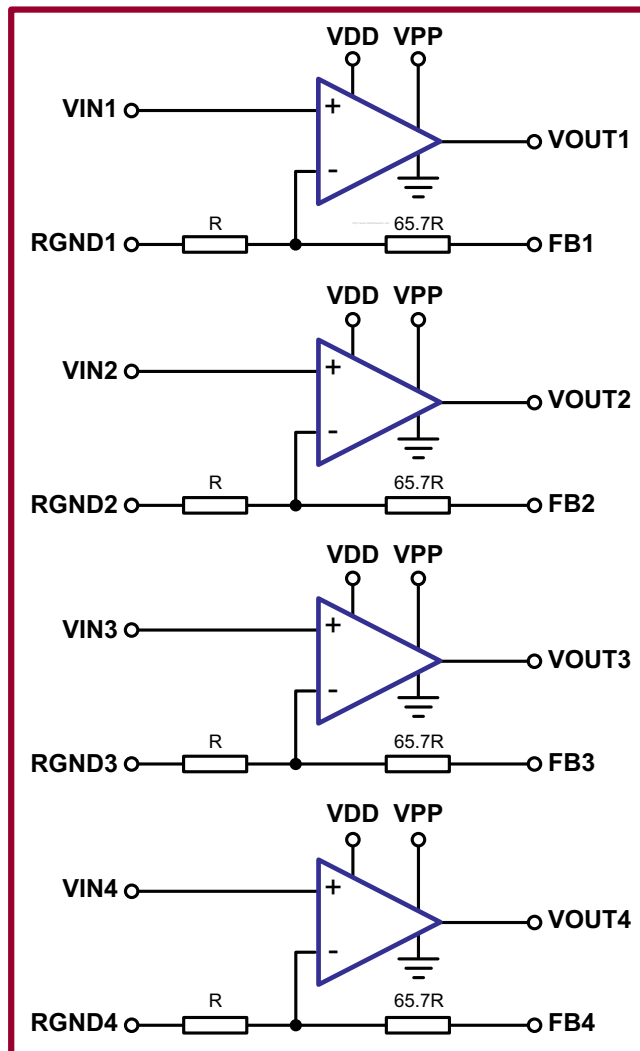

## Ordering Information

Part Number	Package Option	Packing
HV264TS-G	24-Lead TSSOP	2500/Reel

-G denotes a lead (Pb)-free / RoHS compliant package



## Pin Configuration

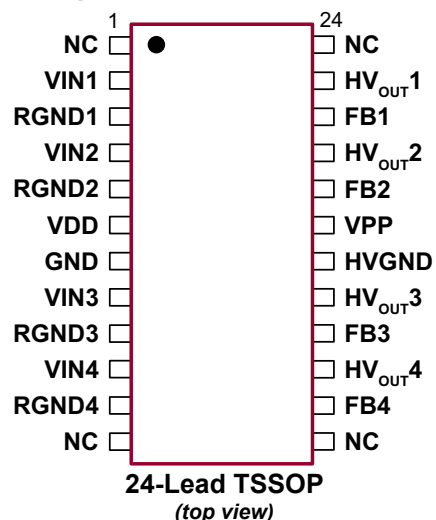

## Absolute Maximum Ratings

Parameter	Value
$V_{PP}$ , High voltage supply	225V
$V_{DD}$ , Low voltage supply	6.5V
$HV_{OUT}$ , Output voltage	0V to VPP
$V_{IN}$ , Analog input signal	0V to VDD
Storage temperature range	-65°C to 150°C
Maximum junction temperature	150°C

Stresses beyond those listed under "Absolute Maximum Ratings" may cause permanent damage to the device. These are stress ratings only, and functional operation of the device at these or any other conditions beyond those indicated in the operational sections of the specifications is not implied. Exposure to absolute maximum rating conditions for extended periods may affect device reliability.

## Thermal Resistance

Package	$\theta_{ja}$
24-Lead TSSOP	72°C/W

## Product Marking

Top Marking



Bottom Marking

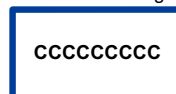

YY = Year Sealed  
 WW = Week Sealed  
 L = Lot Number  
 C = Country of Origin\*  
 A = Assembler ID  
 \_\_\_\_\_ = "Green" Packaging  
 \*May be part of ejector pin

Package may or may not include the following marks: Si or

24-Lead TSSOP

## Operating Conditions

Sym	Parameter	Min	Typ	Max	Unit	Conditions
$V_{PP}$	High voltage positive supply	50	-	200	V	---
$V_{DD}$	Low voltage positive supply	4.5	5.0	5.5	V	---
$R_{GND}$	Input ground range	0	0	$V_{DD}$	V	---
$I_{PP}$	$V_{PP}$ supply current	-	-	300	$\mu$ A	$V_{PP}$ = 200V, All inputs at 0V
$I_{DD}$	$V_{DD}$ supply current	-	-	5.0	mA	$V_{DD}$ = 5.5V
$T_A$	Ambient temperature range	-40	-	85	°C	---
$T_J$	Junction temperature range	-40	-	100	°C	---

## Power Up / Down Sequence

The device can be damaged due to improper power up / down sequence. To prevent damage, please follow the acceptable power up / down sequences and add an external diode across VPP and VDD, where the anode of the diode is connected to VDD and the cathode is connected to VPP. Any low current high voltage diode such as a 1N4004 will be adequate.

## Acceptable Power Up Sequences

- 1)  $V_{DD}$  2)  $V_{PP}$  3) Inputs
- 1)  $V_{DD}$  2) Inputs 3)  $V_{PP}$

## Acceptable Power Down Sequences

- 1) Inputs 2)  $V_{PP}$  3)  $V_{DD}$
- 1)  $V_{PP}$  2) Inputs 3)  $V_{DD}$

## Electrical Characteristics

(Over operating conditions unless otherwise noted,  $T_J = 25^\circ\text{C}$ .)

Sym	Parameter	Min	Typ	Max	Unit	Conditions
<b>High Voltage Amplifier Output</b>						
HV <sub>OUT</sub>	HV <sub>OUT</sub> voltage swing	1.0	-	V <sub>PP</sub> -10	V	No Load
I <sub>SINK</sub>	HV <sub>OUT</sub> sink current	3.0	-	-	mA	---
I <sub>SOURCE</sub>	HV <sub>OUT</sub> source current	3.0	-	-	mA	---
V <sub>IN</sub>	Input voltage range	0	-	V <sub>DD</sub> -1.5	V	---
I <sub>IN</sub>	V <sub>IN</sub> input current	-	-	50	nA	---
HV <sub>OS</sub>	HV <sub>OUT</sub> DC offset	-	-	±1.0	V	V <sub>IN</sub> = 0.2V
SR	HV <sub>OUT</sub> slew rate - rising edge	5.0	9.0	30	V/μs	V <sub>PP</sub> = 200V, Load = 15pF, measured between 10% to 90% of HV <sub>OUT</sub>
	HV <sub>OUT</sub> slew rate - falling edge	-	9.0	-		
R <sub>FB</sub>	Feedback impedance, R <sub>f</sub> + R <sub>i</sub>	3.5	5.3	-	MΩ	---
A <sub>V</sub>	Closed loop gain	63.4	66.7	70.0	V/V	---
BW	HV <sub>OUT</sub> -3dB channel bandwidth	25	-	-	kHz	V <sub>PP</sub> = 200V, Load = 15pF
C <sub>LOAD</sub>	HV <sub>OUT</sub> capacitive load	0	-	15	pF	---
V <sub>N</sub>	Output referred noise	-	-	10	mV <sub>RMS</sub>	Measured at HV <sub>OUT</sub> , 0 to 1.0kHz single-pole, V <sub>IN</sub> = 0.2V
PSRR	V <sub>DD</sub> power supply rejection ratio	55	-	-	dB	V <sub>DD</sub> = 4.5 to 5.5V V <sub>PP</sub> = 200V, V <sub>IN</sub> = 0.1V
PSRR	V <sub>PP</sub> power supply rejection ratio	60	-	-	dB	V <sub>DD</sub> = 5.0V V <sub>PP</sub> = 50 to 200V, V <sub>IN</sub> = 0.1V
Xtalk	Crosstalk	-	-	-80	dB	Output referred

Typical Small Signal Pulse Response

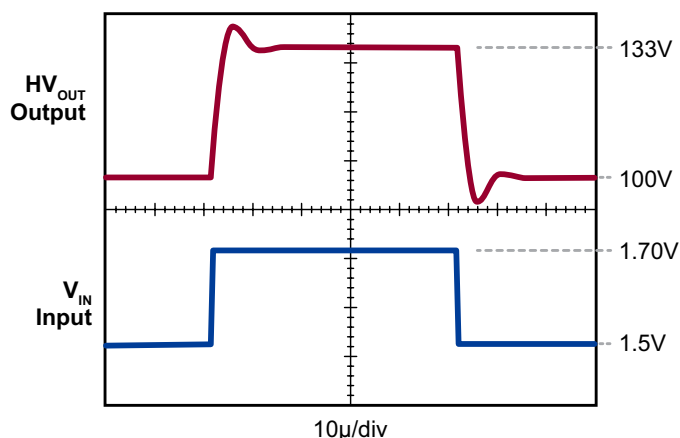

Typical Large Signal Pulse Response

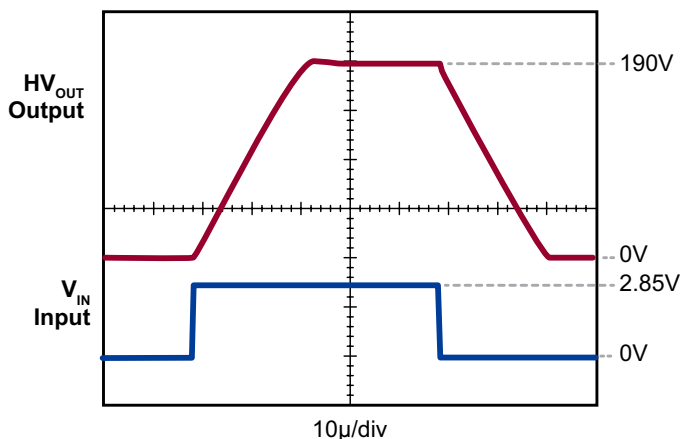

**Typical Bode Plot of Small Signal Gain**

( $V_{IN} = 0.2V_{P-P}$ ,  $V_{DC} = 1.5V$ ,  $V_{DD} = 5.0V$ ,  $V_{PP} = 200V$ )

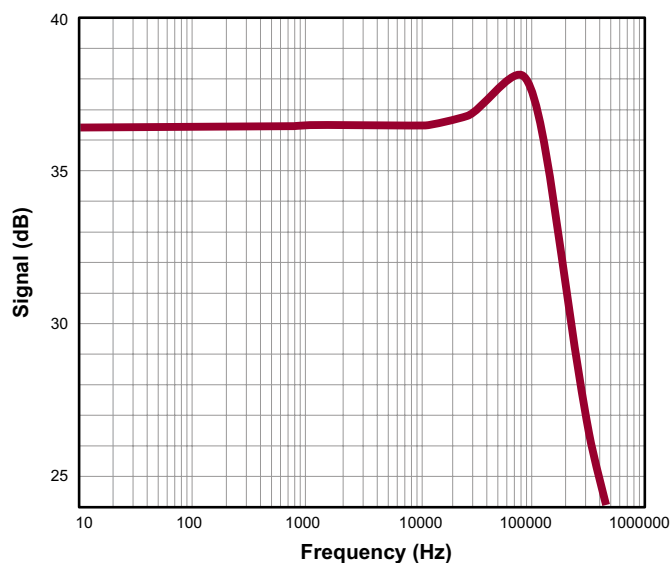

**Distribution of Typical HVOUT Deviation Over Temperature**

( $V_{IN} = 0.1VDC$ ,  $1.6VDC$ ,  $3.3VDC$ , in reference to  $20^{\circ}C$ )

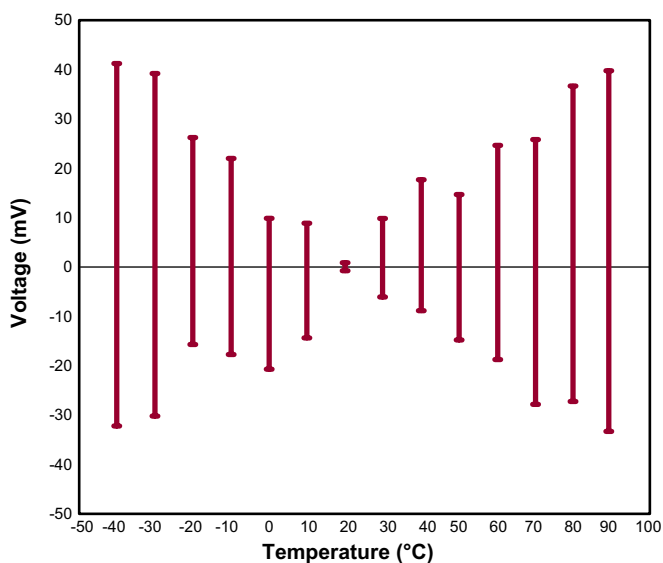

**Typical HVOUT Drift Over Time**

( $V_{PP} = 200V$ ,  $V_{DD} = 5.5V$ ,  $V_{IN} = 0.2V$ , Room Temperature, 50pF Output Loading)

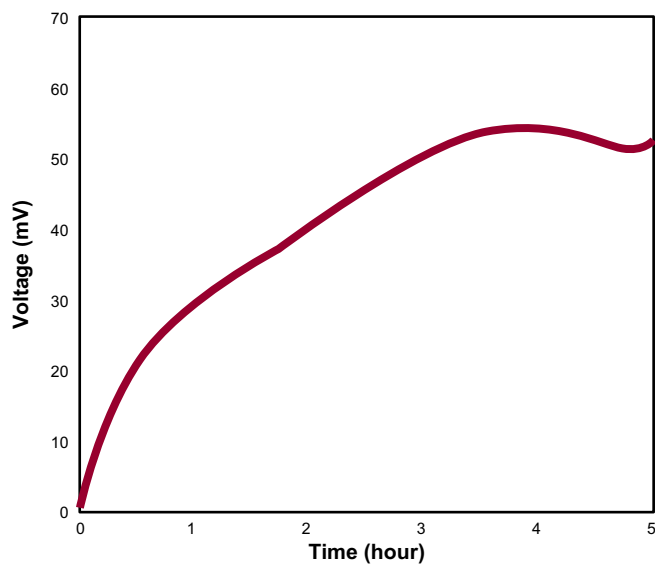

## Typical Application Circuits

### With Internal Gain Setting Resistors

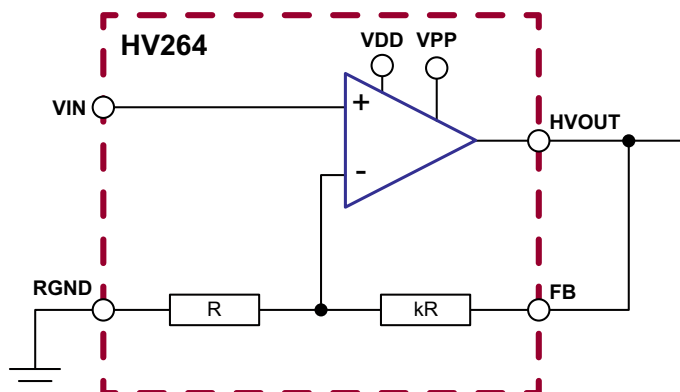

### With External Gain Setting Resistors

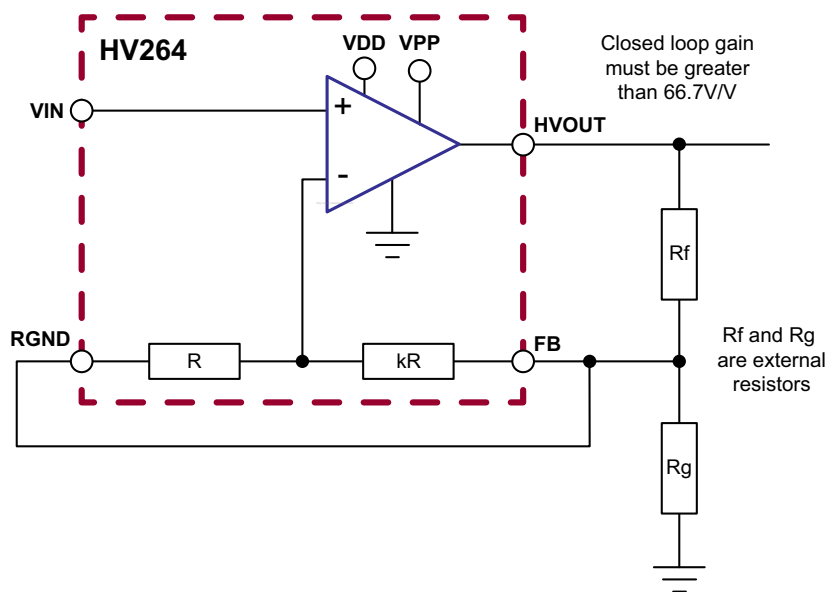

## Pin Description - 24-Lead TSSOP

Pin	Name	Description
1	NC	No Connection
2	VIN1	Amplifier input 1
3	RGND1	Resistor ground for channel 1. Typically grounded. Can be connected to a voltage source to create a DC offset.
4	VIN2	Amplifier input 2
5	RGND2	Resistor ground for channel 2. Typically grounded. Can be connected to a voltage source to create a DC offset.
6	VDD	Low voltage positive supply
7	GND	Device ground
8	VIN3	Amplifier input 3
9	RGND3	Resistor ground for channel 3. Typically grounded. Can be connected to a voltage source to create a DC offset.
10	VIN4	Amplifier input 4
11	RGND4	Resistor ground for channel 4. Typically grounded. Can be connected to a voltage source to create a DC offset.
12	NC	No Connection
13	NC	No Connection
14	FB4	Feedback input 4
15	HVOUT4	Amplifier output 4
16	FB3	Feedback input 3
17	HVOUT3	Amplifier output 3
18	HVGND	Device high voltage supply ground
19	VPP	High voltage positive supply
20	FB2	Feedback input 2
21	HVOUT2	Amplifier output 2
22	FB1	Feedback input 1
23	HVOUT1	Amplifier output 1
24	NC	No Connection

# 24-Lead TSSOP Package Outline (TS)

7.80x4.40mm body, 1.20mm height (max), 0.65mm pitch

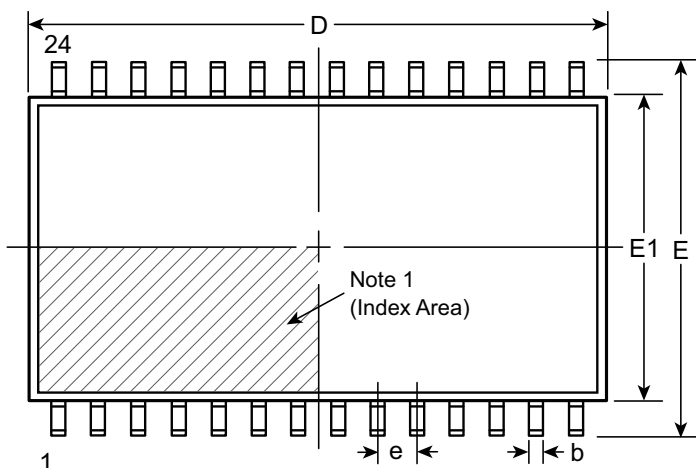

**Top View**

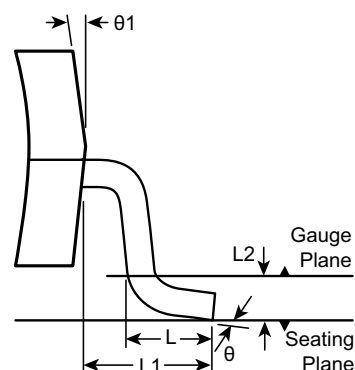

**View B**

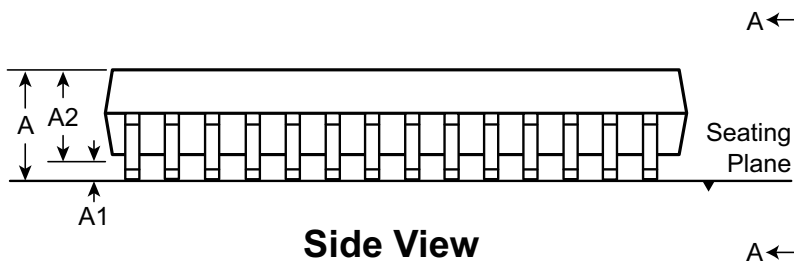

**Side View**

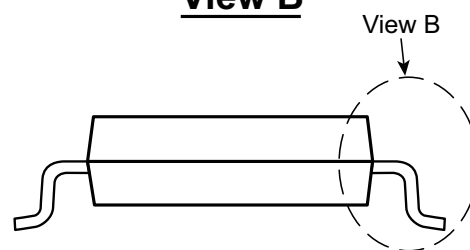

**View A-A**

**Note:**  
 1. A Pin 1 identifier must be located in the index area indicated. The Pin 1 identifier can be: a molded mark/identifier; an embedded metal marker; or a printed indicator.

Symbol	A	A1	A2	b	D	E	E1	e	L	L1	L2	θ	θ1	
Dimension (mm)	MIN	0.85*	0.05	0.80	0.19	7.70	6.20*	4.30	0.65 BSC	0.45	1.00 REF	0.25 BSC	0°	12° REF
	NOM	-	-	1.00	-	7.80	6.40	4.40		0.60		-		
	MAX	1.20	0.15	1.15†	0.30	7.90	6.60*	4.50		0.75		8°		

JEDEC Registration MS-153, Variation AD, Issue F, May 2001.

\* This dimension is not specified in the JEDEC drawing.

† This dimension differs from the JEDEC drawing.

Drawings are not to scale.

Supertex Doc. #: DSPD-24TSSOPTS, Version B041309.

(The package drawing(s) in this data sheet may not reflect the most current specifications. For the latest package outline information go to <http://www.supertex.com/packaging.html>.)

**Supertex inc.** does not recommend the use of its products in life support applications, and will not knowingly sell them for use in such applications unless it receives an adequate "product liability indemnification insurance agreement." **Supertex inc.** does not assume responsibility for use of devices described, and limits its liability to the replacement of the devices determined defective due to workmanship. No responsibility is assumed for possible omissions and inaccuracies. Circuitry and specifications are subject to change without notice. For the latest product specifications refer to the **Supertex inc.** (website: <http://www.supertex.com>)