



PROPRIETARY NOTE
THIS SPECIFICATION IS THE PROPERTY OF BOE HF AND SHALL NOT BE REPRODUCED OR COPIED WITHOUT THE WRITTEN PERMISSION OF BOE HF AND MUST BE RETURNED TO BOE HF UPON ITS REQUEST.

SPEC. NUMBER	PRODUCT GROUP TFT-LCD	REV. A	ISSUE DATE 2011.05.10	PAGE 1 OF 22
---------------------	---------------------------------	------------------	---------------------------------	------------------------

TITLE : HV320WX2-101 Open Cell
Product Specification
Rev. A

Contents

No	ITEM	Page
	REVISIONS HISTORY	2
	CONTENTS	3
1	GENERAL DESCRIPTION	4
	1.1 Introduction	
	1.2 Features	
	1.3 Applications	
	1.4 General Specification	
2	ABSOLUTE MAXIMUM RATINGS	6
3	ELECTRICAL SPECIFICATIONS	7
4	INTERFACE CONNECTION	8
	4.1 Open Cell Input Signal & power	
	4.2 LVDS Interface	
5	SIGNAL TIMING SPECIFICATIONS	10
	5.1 Timing Parameter	
	5.2 Signal Timing Waveform	
	5.3 Input Signals, Basic Display Colors & Cray Scale Of Colors	
	5.4 Power Sequence	
6	OPTICAL SPECIFICATIONS	14
7	MECHANICAL CHARACTERISTICS	16
8	PRODUCT SERIAL NUMBER	17
9	PACKING INFORMATION	18
10	HANDING & CAUTIONS	20
11	APPENDIX	21

1.0 GENERAL DESCRIPTION

1.1 Introduction

HV320WX2-101 is a color active matrix TFT LCD Open Cell using amorphous silicon TFT's (Thin Film Transistors) as an active switching devices. This Open Cell has a 31.5inch diagonally measured active area with WXGA resolutions (1366 horizontal by 768 vertical pixel array). Each pixel is divided into RED, GREEN, BLUE dots which are arranged in vertical stripe and this Open Cell can display 16.7M colors. The TFT-LCD panel used for this Open Cell is adapted for a low reflection and higher color type.

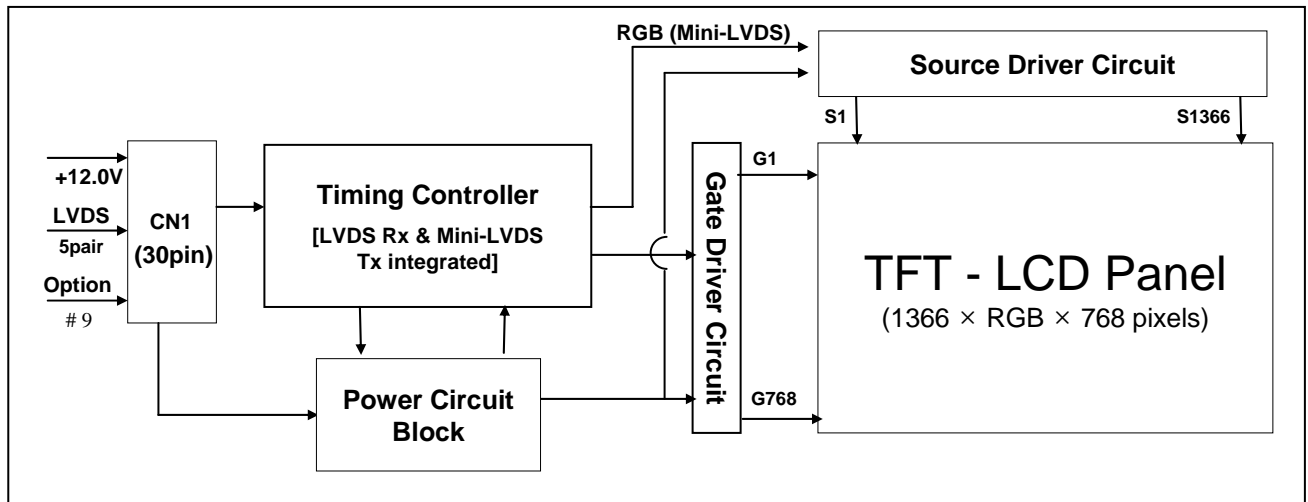

1.2 Features

- LVDS Interface with 1 pixel / clock
- High-speed response
- Lower Color shift Image Quality
- 8-bit Hi-FRC color depth, display 16.7M colors
- High luminance and contrast ratio, low reflection and wide viewing angle
- DE (Data Enable) only mode
- RoHS Compliant

1.3 Application

- Home Alone Multimedia TFT-LCD TV
- Display Terminals for Control System
- High Definition TV(HD TV)
- AV application Products

1.4 General Specification

< Table 1. General Specifications >

Parameter	Specification	Unit	Remarks
Active area	697.685(H) x 392.256(V)	mm	
Number of pixels	1366(H) × 768(V)	pixels	
Pixel pitch	170.25(H) × RGB × 510.75(V)	μm	
Pixel arrangement	Pixels RGB Vertical stripe		
Display colors	16.7M(8bits)	colors	
Display mode	Transmission mode, Normally Black		
Weight	1175 (typ.)	g	
Power Consumption	3	Watt	
Surface Treatment	Haze 10%, 3H, Semi-glare treatment (Front Polarizer)		
Open Cell TR.	5.25	%	At center point with BOE module

2.0 ABSOLUTE MAXIMUM RATINGS

The followings are maximum values which, if exceed, may cause faulty operation or damage to the unit. The operational and non-operational maximum voltage and current values are listed in Table 2.

< Table 2. LCD panel Electrical Specifications >

[VSS=GND=0V]

Parameter	Symbol	Min.	Max.	Unit	Remarks
Power Supply Voltage	VDD	10.8	13.2	V	Ta = 25 °C
Operating Temperature	T _{OP}	0	+50	°C	1)
	T _{SUR}	0	+60	°C	
Storage Temperature	T _{ST}	-20	+60	°C	
Operating Ambient Humidity	Hop	10	80	%RH	
Storage Humidity	Hst	10	80	%RH	

Note : 1) Temperature and relative humidity range are shown in the figure below.

Wet bulb temperature should be 39 °C max. and no condensation of water.

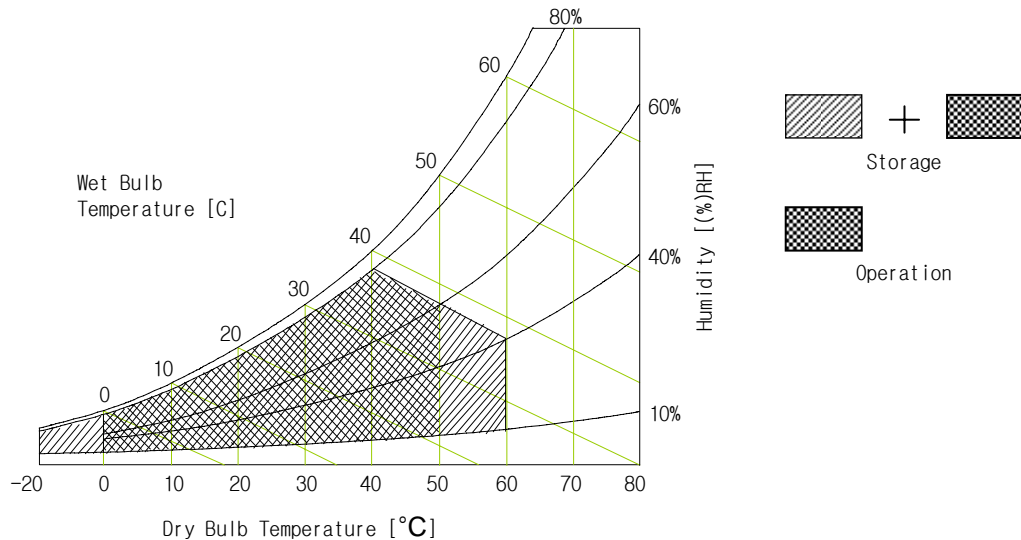

3.0 ELECTRICAL SPECIFICATIONS

3.1 TFT LCD panel

< Table 3. LCD panel Electrical Specifications >

[Ta =25±2 °C]

Parameter	Symbol	Values			Unit	Notes
		Min	Typ	Max		
Power Supply Input Voltage	VDD	10.8	12	13.2	V	
Power Supply Current	IDD	200	250	350	mA	1
Power Consumption	PDD	2	3	5	Watt	
Vsync Frequency	f _V	47	60	63	Hz	
Hsync Frequency	f _H	39.4	47.4	53	KHz	
Main Clock Frequency	PLCD	-	80.4	85	MHz	
Rush current	IRUSH	-	-	2.0	A	2

Notes : 1. The supply voltage is measured and specified at the interface connector of LCM.

The current draw and power consumption specified is for VDD=12.0V, Frame rate=60Hz and Clock frequency = 75.4MHz. Test Pattern of power supply current

a) Typ : Black Pattern

b) Max : Sub Dot Pattern

2. The duration of rush current is about 2ms and rising time of Power Input is 1ms(min)

White : 255Gray
Black : 0Gray

Mosaic Pattern(8 x 6)

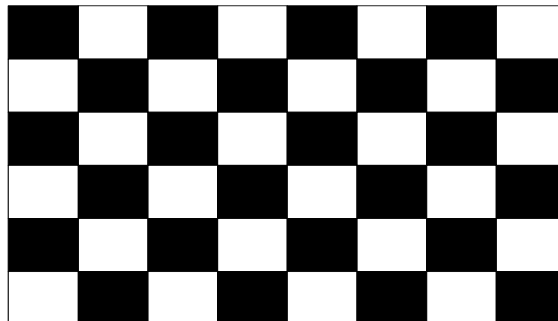

4.0 INTERFACE CONNECTION

4.1 panel Input Signal & Power

- Connector : IS100-L30B-C23(Manufactured by UJU) or Equivalent.

< Table 4. LCM panel Input Connector Pin Configuration >

Pin No	Symbol	Description	Pin No	Symbol	Description
1	VDD	Power Supply +12.0V	16	RX1+	LVDS Receiver Signal(+)
2	VDD	Power Supply +12.0V	17	GND	Ground
3	VDD	Power Supply +12.0V	18	RX2-	LVDS Receiver Signal(-)
4	VDD	Power Supply +12.0V	19	RX2+	LVDS Receiver Signal(+)
5	GND	Ground	20	GND	Ground
6	GND	Ground	21	RCLK-	LVDS Receiver Clock Signal(-)
7	GND	Ground	22	RCLK+	LVDS Receiver Clock Signal(+)
8	GND	Ground	23	GND	Ground
9	LVDS_SEL	'H'=JEIDA , 'L' or NC= VESA	24	RX3-	LVDS Receiver Signal(-)
10	NC	No Connection	25	RX3+	LVDS Receiver Signal(+)
11	GND	Ground	26	GND	Ground
12	RX0-	LVDS Receiver Signal(-)	27	NC	No Connection
13	RX0+	LVDS Receiver Signal(+)	28	NC	No Connection
14	GND	Ground	29	GND	Ground
15	RX1-	LVDS Receiver Signal(-)	30	GND	Ground

Notes : 1. NC (Not Connected) : This pins are only used for BOE internal operations.

2. Input Level of LVDS signal is based on the IEA 664 Standard.

3. LVDS_SEL : This pin is used for selecting LVDS signal data format.

If this Pin : Low (GND) or Open (NC) → Normal NS LVDS format

Otherwise : High (3.3V) → JEIDA LVDS format

Sequence : On = Vdd ≥ LVDS Option ≥ Interface signal

Off = Interface signal ≥ LVDS Option ≥ Vdd

Rear view of LCM

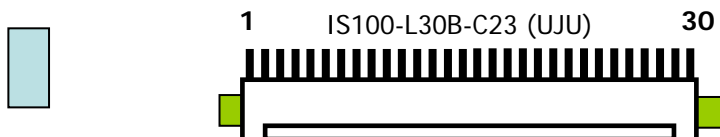

4.2 LVDS Interface

- LVDS Receiver : Timing Controller (LVDS Rx merged)

- LVDS Data : Pixel Data

< Table 5. LCM panel Input Connector Pin Configuration >

	LVDS Pin	Vesa Data format	JEIDA Data format	Remark
TxOUT/RxIN0	TxIN/RxOUT0	Red0 [LSB]	R2	
	TxIN/RxOUT1	Red1	R3	
	TxIN/RxOUT2	Red2	R4	
	TxIN/RxOUT3	Red3	R5	
	TxIN/RxOUT4	Red4	R6	
	TxIN/RxOUT6	Red5	R7 [MSB]	
	TxIN/RxOUT7	Green0 [LSB]	G2	
TxOUT/RxIN1	TxIN/RxOUT8	Green1	G3	
	TxIN/RxOUT9	Green2	G4	
	TxIN/RxOUT12	Green3	G5	
	TxIN/RxOUT13	Green4	G6	
	TxIN/RxOUT14	Green5	G7 [MSB]	
	TxIN/RxOUT15	Blue0 [LSB]	B2	
	TxIN/RxOUT18	Blue1	B3	
TxOUT/RxIN2	TxIN/RxOUT19	Blue2	B4	
	TxIN/RxOUT20	Blue3	B5	
	TxIN/RxOUT21	Blue4	B6	
	TxIN/RxOUT22	Blue5	B7 [MSB]	
	TxIN/RxOUT24	HSYNC	HSYNC	
	TxIN/RxOUT25	VSYNC	VSYNC	
	TxIN/RxOUT26	DEN	DEN	
TxOUT/RxIN3	TxIN/RxOUT27	Red6	R0 [LSB]	
	TxIN/RxOUT5	Red7 [MSB]	R1	
	TxIN/RxOUT10	Green6	G0 [LSB]	
	TxIN/RxOUT11	Green7 [MSB]	G1	
	TxIN/RxOUT16	Blue6	B0 [LSB]	
	TxIN/RxOUT17	Blue7 [MSB]	B1	
	TxIN/RxOUT23	Reserved	Reserved	

5.0 SIGNAL TIMING SPECIFICATION

5.1 Timing Parameters (DE only mode)

< Table 6. Timing Table >

ITEM	Symbol		Min	Typ	Max	Unit	Note
CLK	Period	t_{CLK}	11.5	12.8	15.0	ns	
	Frequency	-	70.5	78.4	90.0	MHz	
Hsync	Period	t_{HP}	1416	1560	1776	t_{CLK}	
	Frequency	f_H	39.4	47.4	53	KHz	
Vsync	Period	t_{VP}	775	790	1063	t_{HP}	
	Frequency	f_V	47	60	63	Hz	
Horizontal Active Display Term	Valid	t_{HV}	-	1366	-	t_{CLK}	
	Total	t_{HP}	1440	1560	2000	t_{CLK}	
Vertical Active Display Term	Valid	t_{VV}	-	768	-	t_{HP}	
	Total	t_{VP}	773	838	1200	t_{HP}	

Notes: This product is DE only mode. The input of Hsync & Vsync signal does not have an effect on normal operation.

5.2 Signal Timing Waveform

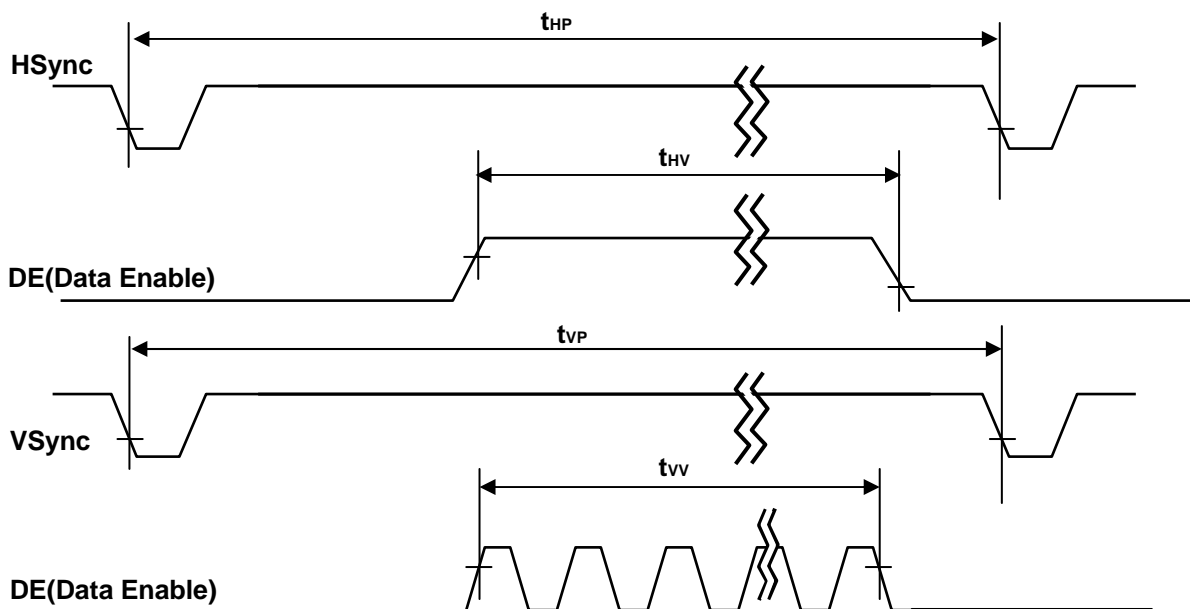
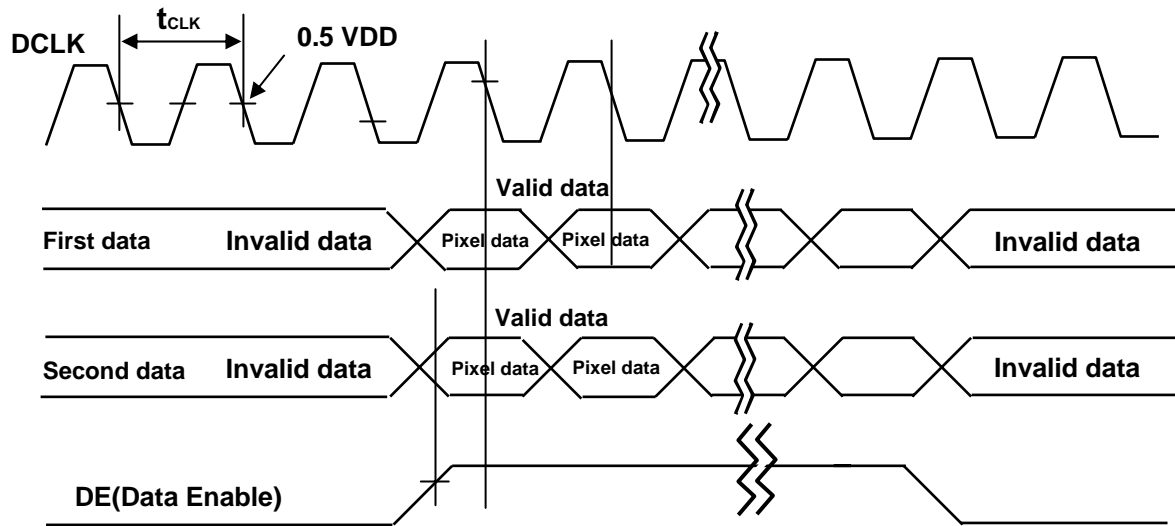

5.3 Input Signals, Basic Display Colors & Gray Scale Of Colors

< Table 7. Input Signal and Display Color Table >

Color & Gray Scale		Input Data Signal																							
		Red Data								Green Data				Blue Data											
		R7	R6	R5	R4	R3	R2	R1	R0	G7	G6	G5	G4	G3	G2	G1	G0	B7	B6	B5	B4	B3	B2	B1	B0
Basic Colors	Black	0	0	0	0	0	0	0	0	0	0	0	0	0	0	0	0	0	0	0	0	0	0	0	0
	Blue	0	0	0	0	0	0	0	0	0	0	0	0	0	0	0	0	1	1	1	1	1	1	1	1
	Green	0	0	0	0	0	0	0	0	1	1	1	1	1	1	1	1	0	0	0	0	0	0	0	0
	Cyan	0	0	0	0	0	0	0	0	1	1	1	1	1	1	1	1	1	1	1	1	1	1	1	1
	Red	1	1	1	1	1	1	1	1	0	0	0	0	0	0	0	0	0	0	0	0	0	0	0	0
	Magenta	1	1	1	1	1	1	1	1	0	0	0	0	0	0	0	0	1	1	1	1	1	1	1	1
	Yellow	1	1	1	1	1	1	1	1	1	1	1	1	1	1	1	1	0	0	0	0	0	0	0	0
	White	1	1	1	1	1	1	1	1	1	1	1	1	1	1	1	1	1	1	1	1	1	1	1	1
Gray Scale of Red	Black	0	0	0	0	0	0	0	0	0	0	0	0	0	0	0	0	0	0	0	0	0	0	0	
	△	0	0	0	0	0	0	0	1	0	0	0	0	0	0	0	0	0	0	0	0	0	0	0	
	Darker	0	0	0	0	0	0	1	0	0	0	0	0	0	0	0	0	0	0	0	0	0	0	0	
	△	↑								↑				↑											
	▽	↓								↓				↓											
	Brighter	1	1	1	1	1	1	0	1	0	0	0	0	0	0	0	0	0	0	0	0	0	0	0	0
	▽	1	1	1	1	1	1	1	0	0	0	0	0	0	0	0	0	0	0	0	0	0	0	0	0
Gray Scale of Green	Red	1	1	1	1	1	1	1	0	0	0	0	0	0	0	0	0	0	0	0	0	0	0	0	
	Black	0	0	0	0	0	0	0	0	0	0	0	0	0	0	0	0	0	0	0	0	0	0	0	
	△	0	0	0	0	0	0	0	0	0	0	0	0	0	0	0	1	0	0	0	0	0	0	0	
	Darker	0	0	0	0	0	0	0	0	0	0	0	0	0	0	1	0	0	0	0	0	0	0	0	
	△	↑								↑				↑											
	▽	↓								↓				↓											
	Brighter	0	0	0	0	0	0	0	0	1	1	1	1	1	1	0	1	0	0	0	0	0	0	0	
Gray Scale of Blue	Green	0	0	0	0	0	0	0	0	1	1	1	1	1	1	1	0	0	0	0	0	0	0	0	
	Black	0	0	0	0	0	0	0	0	0	0	0	0	0	0	0	0	0	0	0	0	0	0	0	
	△	0	0	0	0	0	0	0	0	0	0	0	0	0	0	0	0	0	0	0	0	0	0	1	
	Darker	0	0	0	0	0	0	0	0	0	0	0	0	0	0	0	0	0	0	0	0	0	0	1	
	△	↑								↑				↑											
	▽	↓								↓				↓											
	Brighter	0	0	0	0	0	0	0	0	0	0	0	0	0	0	0	1	1	1	1	1	1	0	1	
Gray Scale of White	Blue	0	0	0	0	0	0	0	0	0	0	0	0	0	0	0	1	1	1	1	1	1	1	1	
	Black	0	0	0	0	0	0	0	0	0	0	0	0	0	0	0	0	0	0	0	0	0	0	0	
	△	0	0	0	0	0	0	0	1	0	0	0	0	0	0	0	1	0	0	0	0	0	0	1	
	Darker	0	0	0	0	0	0	1	0	0	0	0	0	0	0	1	0	0	0	0	0	0	0	1	
	△	↑								↑				↑											
	▽	↓								↓				↓											
	Brighter	1	1	1	1	1	1	0	1	1	1	1	1	1	0	1	1	1	1	1	1	1	0	1	
White	1	1	1	1	1	1	1	1	1	1	1	1	1	1	1	1	1	1	1	1	1	1	1	1	

5.4 Power Sequence

To prevent a latch-up or DC operation of the LCD panel, the power on/off sequence shall be as shown in below

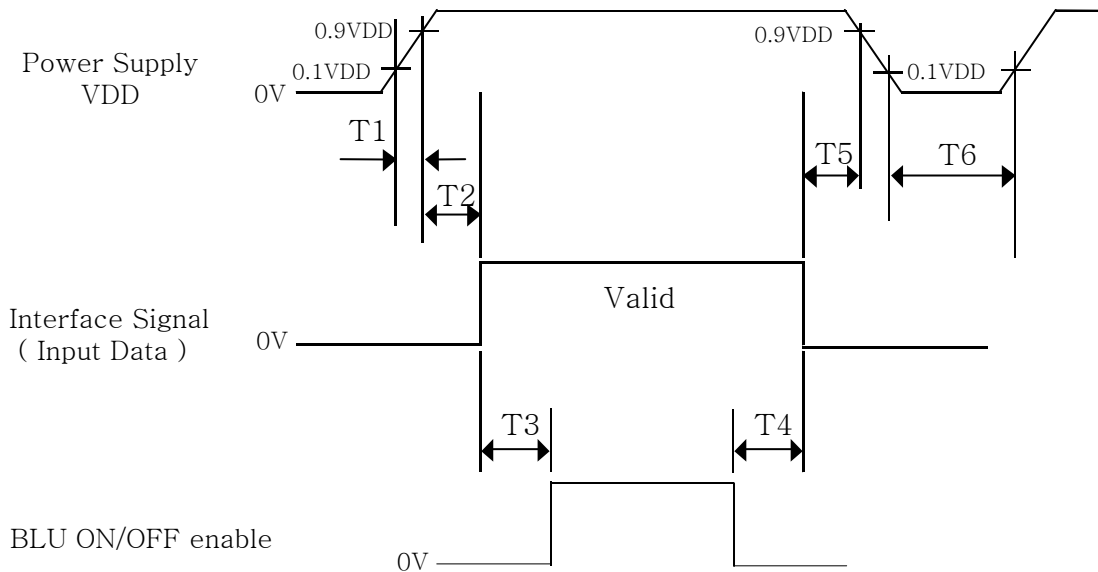

< Table 8. Sequence Table >

Parameter	Values			Units
	Min	Typ	Max	
T1	0.5	-	10	ms
T2	0.5	-	50	ms
T3	1	-	-	ms
T4	100	-	-	ms
T5	0.5	-	50	ms
T6	3.0	-	-	s

Notes:

1. When the power supply VDD is 0V, Keep the level of input signals on the low or keep high impedance.
2. Do not keep the interface signal high impedance when power is on.
3. Back Light must be turn on after power for logic and interface signal are valid.

6.0 OPTICAL SPECIFICATION

The test of Optical specifications shall be measured in a dark room (ambient luminance ≤ 1 lux and temperature = $25 \pm 2^\circ\text{C}$) with the equipment of Luminance meter system (Goniometer system and TOPCON BM-5) and test unit shall be located at an approximate distance 50cm from the LCD surface at a viewing angle of Θ and Φ equal to 0° . We refer to $\Theta_{\phi=0}$ ($=\Theta_3$) as the 3 o'clock direction (the "right"), $\Theta_{\phi=90}$ ($=\Theta_{12}$) as the 12 o'clock direction ("upward"), $\Theta_{\phi=180}$ ($=\Theta_9$) as the 9 o'clock direction ("left") and $\Theta_{\phi=270}$ ($=\Theta_6$) as the 6 o'clock direction ("bottom"). While scanning Θ and/or Φ , the center of the measuring spot on the Display surface shall stay fixed. The measurement shall be executed after 30 minutes warm-up period. VDD shall be 12.0V +/-10% at 25°C . Optimum viewing angle direction is 6 o'clock.

[VDD = 12.0V, Frame rate = 60Hz, Ta = $25 \pm 2^\circ\text{C}$]

< Table 9. Optical Table >

Parameter		Symbol	Condition	Min	Typ	Max	Unit	Remark
Viewing Angle	Horizontal	Θ_3	CR > 10		89		Deg.	Note 1
		Θ_9			89		Deg.	
	Vertical	Θ_{12}			89		Deg.	
		Θ_6			89		Deg.	
Contrast ratio		CR		900:1	1200:1	-		Note 2
Reproduction of color	White	W_x	$\Theta = 0^\circ$ (center) Normal Viewing Angle with BOE module	TYP. - 0.03	0.279	TYP. + 0.03		Note 3
		W_y			0.292			
	Red	R_x			0.636			
		R_y			0.335			
	Green	G_x			0.291			
		G_y			0.603			
	Blue	B_x			0.146			
		B_y			0.061			
Response Time	G to G	T_g		-	8	10	ms	Note 4
Cell Transmittance					5.25			Note 5
Gamma Scale				2.0	2.2	2.4		

Note :

1. Viewing angle is the angle at which the contrast ratio is greater than 10. The viewing are determined for the horizontal or 3, 9 o'clock direction and the vertical or 6, 12 o'clock direction with respect to the optical axis which is normal to the LCD surface.
2. Contrast measurements shall be made at viewing angle of $\theta = 0^\circ$ and at the center of the LCD surface. Luminance shall be measured with all pixels in the view field set first to white, then to the dark (black) state. (See FIGURE 1 shown in Appendix) Luminance Contrast Ratio (CR) is defined mathematically.

$$CR = \frac{\text{Luminance when displaying a white raster}}{\text{Luminance when displaying a black raster}}$$

3. The color chromaticity coordinates specified in Table 9. shall be calculated from the spectral data measured with all pixels first in red, green, blue and white. Measurements shall be made at the center of the panel.
4. Response time T_g is the average time required for display transition by switching the input signal as FIGURE 2 shown in Appendix and is based on $f_v = 60\text{Hz}$ to optimize.
5. Definition of Transmittance (T%) :
Module is with white(L255) signal input

$$\text{Transmittance} = \frac{\text{Luminance of LCD module}}{\text{Luminance of Backlight}} * 100\%$$

7.0 MECHANICAL CHARACTERISTICS

7.1 Dimensional Requirements

FIGURE 4 (located in Appendix) shows mechanical outlines for the model HV320WX2-101 . Other parameters are shown in Table 10.

<Table 10. Dimensional Parameters>

Parameter	Specification	Unit
Weight	1175(typ)	gram
Active area	697.685(H) x 392.256(V)	mm
Pixel pitch	0.51(H) × 0.51(V)	mm
Number of pixels	1366(H) × 768(V) (1 pixel = R + G + B dots)	pixels

7.2 Semi-Glare and Polarizer Hardness.

The surface of the LCD has an semi-glare coating to minimize reflection and a coating to reduce scratching.

8.0 PRODUCT SERIAL NUMBER

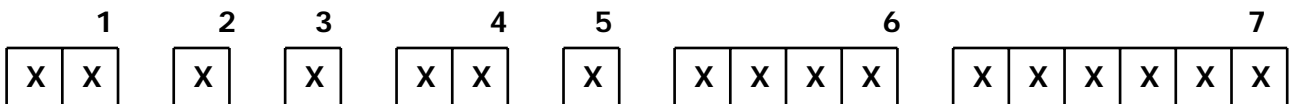

- 1. Control Number
- 2. Rank / Grade
- 3. Line Classification
- 4. Year (2011 : 11, 2012 : 12, ...)

- 5. Month (1,2,3, ... , 9, X, Y, Z)
- 6. Internal Use
- 7. Serial Number

9.0 PACKING INFORMATION

BOE provides the standard shipping container for customers, unless customer specifies their packing information. The standard packing method and Barcode information are shown in below.

9.1 Packing Order

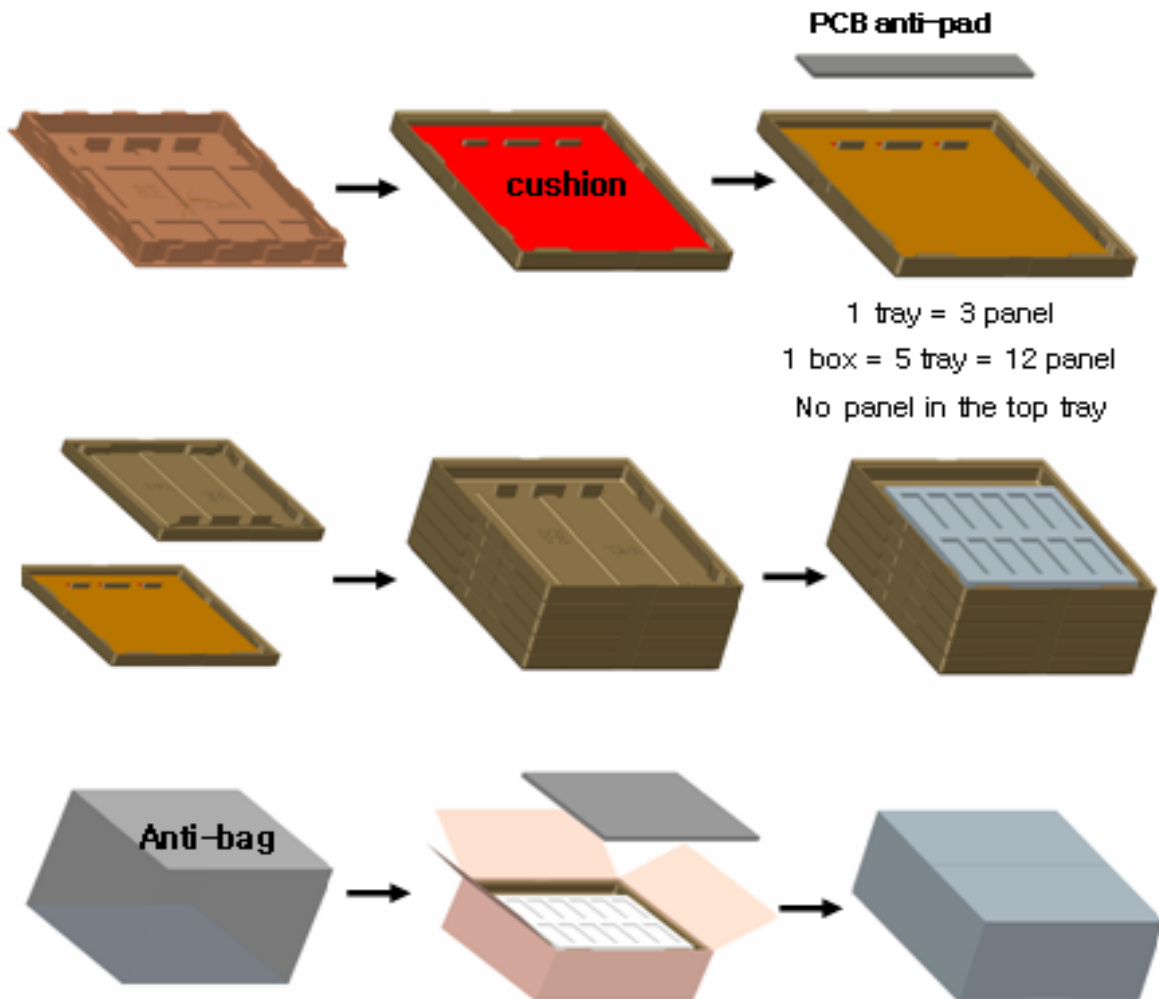



PRODUCT GROUP

REV

ISSUE DATE

TFT- LCD PRODUCT

A

2011.05.10

SPEC. NUMBER

SPEC. TITLE ; HV320WX2-101 Open Cell
Product Specification

PAGE

19 OF 22

9.2 Packing Note

- Box Dimension : 880L× 610W× 250H
- Package Quantity in one Box : 12pcs

9.3 Box label

- Label Size : 108 mm (L) 56 mm (W)
- Contents

Model : HV320WX2-101

Serial No. : Box Serial No. See next page for detail description.

Date : Packing Date

FG Code : FG Code of Product

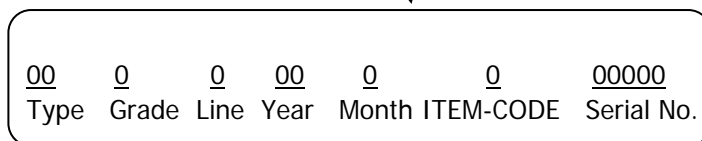
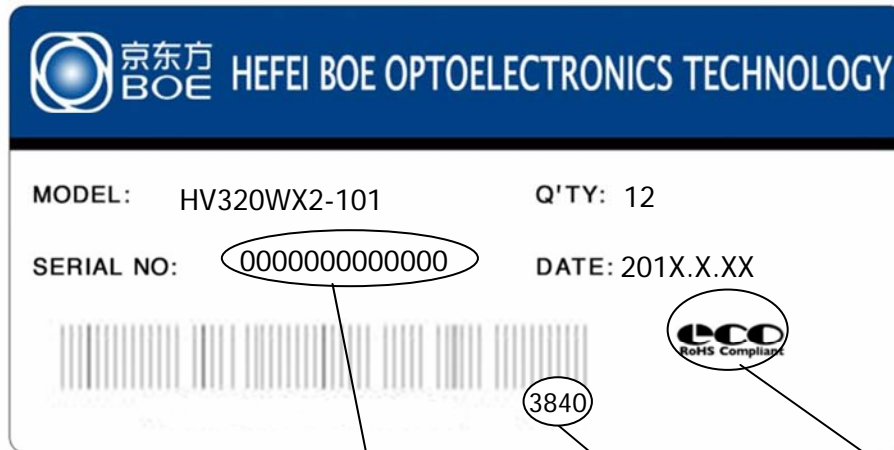

FG CODE

RoHS Mark

10.0 HANDLING & CAUTIONS

- (1) Cautions when taking out the panel
 - Pick the pouch only, when taking out panel from a shipping package.
- (2) Cautions for handling the panel
 - As the electrostatic discharges may break the LCD panel, handle the LCD panel with care. Peel a protection sheet off from the LCD panel surface as slowly as possible.
 - As the LCD panel and back - light element are made from fragile glass material, impulse and pressure to the LCD panel should be avoided.
 - As the surface of the polarizer is very soft and easily scratched, use a soft dry cloth without chemicals for cleaning.
 - Do not pull the interface connector in or out while the LCD panel is operating.
 - Put the panel display side down on a flat horizontal plane.
 - Handle connectors and cables with care.
- (3) Cautions for the operation
 - When the panel is operating, do not lose CLK, ENAB signals. If any one of these signals is lost, the LCD panel would be damaged.
 - Obey the supply voltage sequence. If wrong sequence is applied, the panel would be damaged.
- (4) Cautions for the atmosphere
 - Dew drop atmosphere should be avoided.
 - Do not store and/or operate the LCD panel in a high temperature and/or humidity atmosphere. Storage in an electro-conductive polymer packing pouch and under relatively low temperature atmosphere is recommended.
- (5) Cautions for the panel characteristics
 - Do not apply fixed pattern data signal to the LCD panel at product aging.
 - Applying fixed pattern for a long time may cause image sticking.
- (6) Other cautions
 - Do not disassemble and/or re-assemble LCD panel.
 - Do not re-adjust variable resistor or switch etc.
 - When returning the panel for repair or etc., Please pack the panel not to be broken. We recommend to use the original shipping packages.

