



PROPRIETARY NOTE
THIS SPECIFICATION IS THE PROPERTY OF BOE DT AND SHALL NOT BE REPRODUCED OR COPIED WITHOUT THE WRITTEN PERMISSION OF BOE DT AND MUST BE RETURNED TO BOE DT UPON ITS REQUEST

HV320WX2-170 Product Specification For LGE

Approved by	
Date	

BEIJING BOE DISPLAY TECHNOLOGY

SPEC. NUMBER S8-64-8A-026	PRODUCT GROUP TFT LCD	REV. 0	ISSUE DATE 2012.12.21	PAGE 1 of 23
------------------------------	--------------------------	-----------	--------------------------	-----------------



京东方
BOE

PRODUCT GROUP

REV

ISSUE DATE

TFT LCD

0

2012.12.21

REVISION HISTORY

REV.	ECN NO.	DESCRIPTION OF CHANGES	DATE	PREPARED
0	-	Initial Release	2012.12.21	孙志华

SPEC. NUMBER S8-64-8A-026	SPEC. TITLE HV320WX2-170 Product Specification For LGE	PAGE 2 of 23
------------------------------	---	-----------------



京东方
BOE

PRODUCT GROUP

REV

ISSUE DATE

TFT LCD

0

2012.12.21

Contents

No	ITEM	Page
	REVISIONS HISTORY	2
	CONTENTS	3
1	GENERAL DESCRIPTION	4
	1.1 Introduction	
	1.2 Features	
	1.3 Applications	
	1.4 General Specification	
2	ABSOLUTE MAXIMUM RATINGS	6
3	ELECTRICAL SPECIFICATIONS	7
	3.1 TFT LCD Open Cell	
4	INTERFACE CONNECTION	8
	4.1 Open Cell Input Signal & Power	
	4.2 LVDS Interface	
5	SIGNAL TIMING SPECIFICATIONS	10
	5.1 Timing Parameters	
	5.2 Signal Timing Waveform	
	5.3 Input Signals, Basic Display Colors & Cray Scale Of Colors	
	5.4 Power Sequence	
6	OPTICAL SPECIFICATIONS	14
7	MECHANICAL CHARACTERISTICS	16
8	RELIABILITY TEST CONDITION	17
9	PRODUCT SERIAL NUMBER	18
10	PACKING INFORMATION	19
11	HANDING & CAUTIONS	21
12	APPENDIX	22

SPEC. NUMBER
S8-64-8A-026

SPEC. TITLE
HV320WX2-170 Product Specification For LGE

PAGE
3 of 23



1.0 GENERAL DESCRIPTION

1.1 Introduction

HV320WX2-170 is a color active matrix TFT LCD open cell using amorphous silicon TFT's (Thin Film Transistors) as an active switching devices. This open cell has a 31.51 inch diagonally measured active area with WXGA resolutions (1366 horizontal by 768 vertical pixel array). Each pixel is divided into RED, GREEN, BLUE dots which are arranged in vertical stripe and this open cell can display 16.7M colors. The TFT-LCD panel used for this open cell is adapted for a low reflection and higher color type.

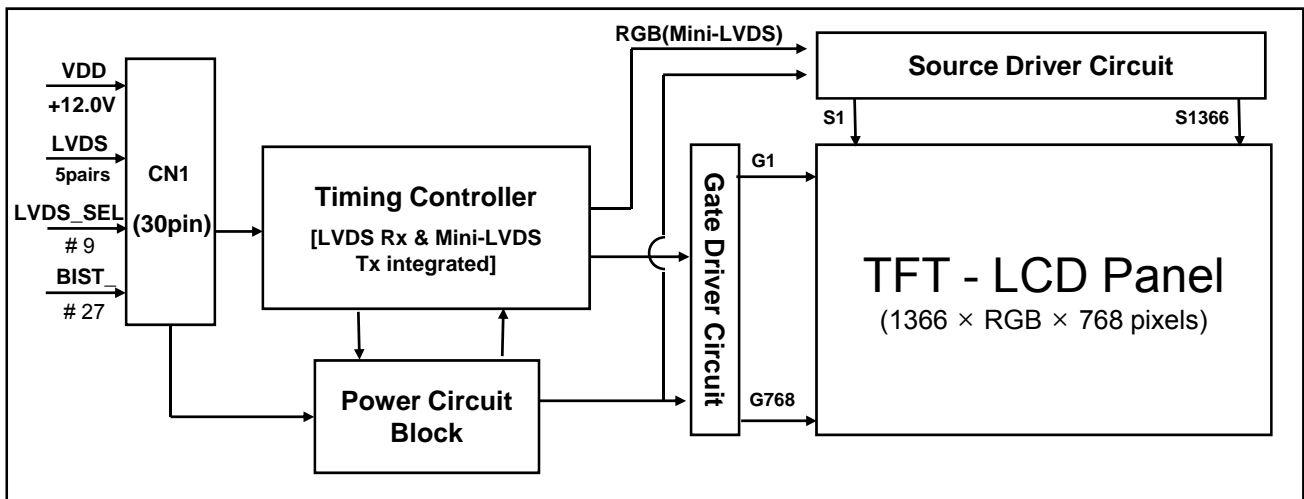

1.2 Features

- LVDS interface with 1 pixel / clock
- High-speed response
- Low color shift image quality
- 8-bit color depth, display 16.7M colors
- High luminance and contrast ratio, low reflection and wide viewing angle
- DE (Data Enable) only mode
- ADS technology is applied for high display quality
- RoHS compliant



京东方
BOE

PRODUCT GROUP

REV

ISSUE DATE

TFT LCD

0

2012.12.21

1.3 Application

- Home Alone Multimedia TFT-LCD TV
- Display Terminals for Control System
- High Definition TV(HD TV)
- AV application Products

1.4 General Specification

< Table 1. General Specifications >

Parameter	Specification	Unit	Remark
Active area	697.685(H) × 392.256(V)	mm	
Number of pixels	1366(H) × 768(V)	pixels	
Pixel pitch	170.25(H) × RGB × 510.75(V)	μm	
Pixel arrangement	Pixels RGB Vertical stripe		
Display colors	16.7M(8bits-true)	colors	
Display mode	Transmission mode, Normally Black		
Open Cell Transmittance	6.6 (typ.)	%	At center point with BOE BLU
Weight	1160 (typ.)	gram	
Power Consumption	4.0 (typ.)	Watt	
Surface Treatment	Haze 1%, 3H, Semi-glare treatment (Front Polarizer) Clear (Bottom Polarizer)		

SPEC. NUMBER
S8-64-8A-026

SPEC. TITLE
HV320WX2-170 Product Specification For LGE

PAGE
5 of 23



2.0 ABSOLUTE MAXIMUM RATINGS

The followings are maximum values which, if exceed, may cause faulty operation or damage to the unit. The operational and non-operational maximum voltage and current values are listed in Table 2.

< Table 2. Open Cell Electrical Specifications >

[VSS=GND=0V]

Parameter	Symbol	Min.	Max.	Unit	Remark
Power Supply Voltage	VDD	VSS-0.3	13.2	V	Ta = 25 °C
Operating Temperature	T _{OP}	0	+50	°C	Note 1
	T _{SUR}	0	+60	°C	
Storage Temperature	T _{ST}	-20	+60	°C	
Operating Ambient Humidity	Hop	10	80	%RH	
Storage Humidity	Hst	10	80	%RH	

Note 1 : Temperature and relative humidity range are shown in the figure below.

Wet bulb temperature should be 39 °C max. and no condensation of water.

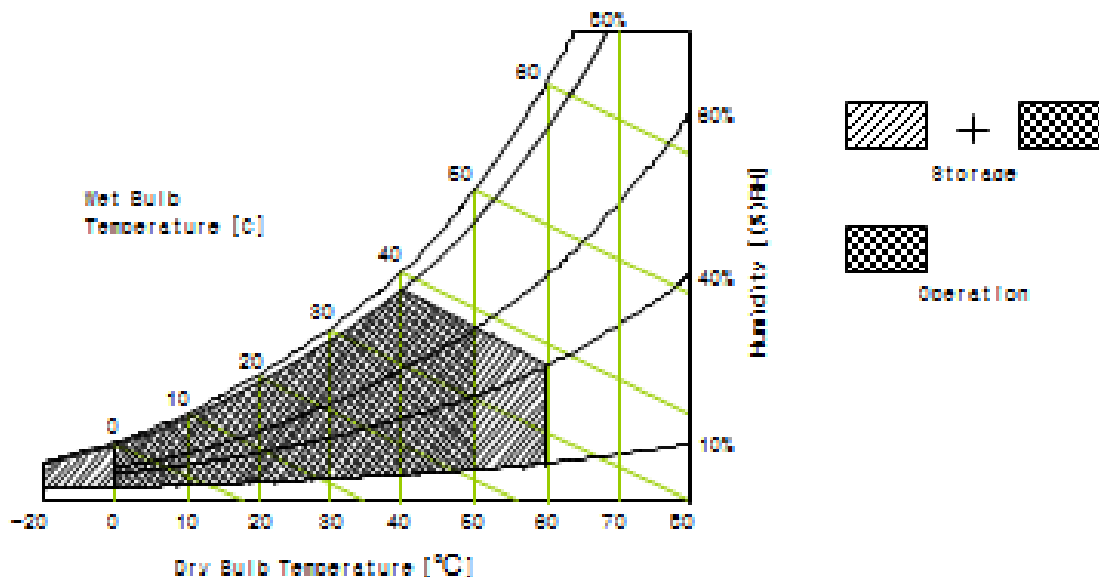



3.0 ELECTRICAL SPECIFICATIONS

3.1 TFT LCD Open Cell

< Table 3. Open Cell Electrical Specifications >

[Ta =25±2 °C]

Parameter		Symbol	Values			Unit	Remark
			Min	Typ	Max		
Power Supply Input Voltage		VDD	10.8	12	13.2	Vdc	
Power Supply Ripple Voltage		VRP			300	mV	
Power Supply Current		IDD	-	333	592	mA	Note 1
Power Consumption		PDD		4.0	7.1	Watt	
Rush current		IRUSH	-	-	3.0	A	Note 2
LVDS Interface	Differential Input High Threshold Voltage	VLVTH	+100		+300	mV	
	Differential Input Low Threshold Voltage	VLVTL	-300		-100	mV	
	Common Input Voltage	VLVC	1.0	1.2	1.4	V	
CMOS Interface	Input High Threshold Voltage	VIH	2.7	-	3.3	V	
	Input Low Threshold Voltage	VIL	0	-	0.6	V	

Note 1 : The supply voltage is measured and specified at the interface connector of LCM.

The current draw and power consumption specified is for VDD=12.0V,

Frame rate $f_v=60\text{Hz}$ and Clock frequency = 75.4MHz.

Test Pattern of power supply current

a) Typ : Mosaic 8 x 6 Pattern(L0/L255)
Pattern(L0/L255)

b) Max : Skip 1H2V Sub Dot

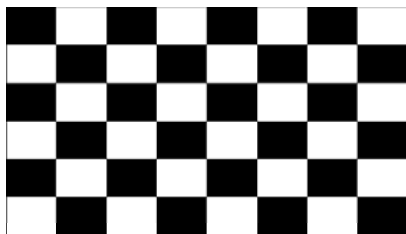

Note 2 : The duration of rush current is about 2ms and rising time of Power Input is 1ms(min)



4.0 INTERFACE CONNECTION

4.1 Module Input Signal & Power

- Connector : FI-X30SSLA(Manufactured by JAE) or Equivalent.

< Table 4. Open Cell Input Connector Pin Configuration >

Pin No	Symbol	Description	Pin No	Symbol	Description
1	VDD	Power Supply +12.0V	16	RX1+	LVDS Receiver Signal(+)
2	VDD	Power Supply +12.0V	17	GND	Ground
3	VDD	Power Supply +12.0V	18	RX2-	LVDS Receiver Signal(-)
4	VDD	Power Supply +12.0V	19	RX2+	LVDS Receiver Signal(+)
5	GND	Ground	20	GND	Ground
6	GND	Ground	21	RCLK-	LVDS Receiver Clock Signal(-)
7	GND	Ground	22	RCLK+	LVDS Receiver Clock Signal(+)
8	GND	Ground	23	GND	Ground
9	LVDS_SEL	'L'=JEIDA , 'H'or NC= VESA	24	RX3-	LVDS Receiver Signal(-)
10	NC	No Connection	25	RX3+	LVDS Receiver Signal(+)
11	GND	Ground	26	GND	Ground
12	RX0-	LVDS Receiver Signal(-)	27	BIST	'L' or NC=Free run mode , 'H'= BIST mode
13	RX0+	LVDS Receiver Signal(+)	28	NC	No Connection
14	GND	Ground	29	NC	No Connection
15	RX1-	LVDS Receiver Signal(-)	30	GND	Ground

Notes : 1. NC(Not Connected) : This pins are only used for BOE internal operations.

2. Input Level of LVDS signal is based on the IEA 664 Standard.

3. LVDS_SEL : This pin is used for selecting LVDS signal data format.

If this Pin : High (3.3V) or Open (NC) → Normal NS LVDS format

Otherwise : Low (GND) → JEIDA LVDS format

4. BIST : This pin is used for selecting display pattern mode when input DE or input CLOCK quits toggling.

If this Pin : Low (GND) or Open (NC) → Free run mode(Black Pattern)

Otherwise : High(3.3V) → BIST mode(BIST Pattern)

Sequence : On = VDD ≥ LVDS Option , BIST Option ≥ Interface signal

Off = Interface signal ≥ LVDS Option , BIST Option ≥ VDD

Rear view of LCM

BIST Pattern

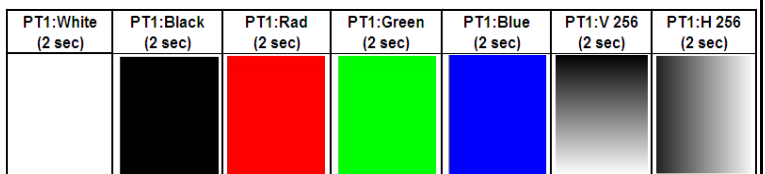
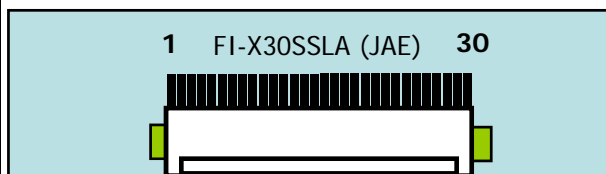

SPEC. NUMBER
S8-64-8A-026

SPEC. TITLE
HV320WX2-170 Product Specification For LGE

PAGE
8 of 23



4.2 LVDS Interface

- LVDS Receiver : Timing Controller (LVDS Rx merged) / LVDS Data : Pixel Data

< Table 5. Open Cell Input Connector Pin Configuration >

	LVDS Pin	Vesa Data format	JEIDA Data format	Remark
TxOUT/RxIN0	TxIN/RxOUT0	Red0 [LSB]	R2	
	TxIN/RxOUT1	Red1	R3	
	TxIN/RxOUT2	Red2	R4	
	TxIN/RxOUT3	Red3	R5	
	TxIN/RxOUT4	Red4	R6	
	TxIN/RxOUT6	Red5	R7 [MSB]	
	TxIN/RxOUT7	Green0 [LSB]	G2	
TxOUT/RxIN1	TxIN/RxOUT8	Green1	G3	
	TxIN/RxOUT9	Green2	G4	
	TxIN/RxOUT12	Green3	G5	
	TxIN/RxOUT13	Green4	G6	
	TxIN/RxOUT14	Green5	G7 [MSB]	
	TxIN/RxOUT15	Blue0 [LSB]	B2	
	TxIN/RxOUT18	Blue1	B3	
TxOUT/RxIN2	TxIN/RxOUT19	Blue2	B4	
	TxIN/RxOUT20	Blue3	B5	
	TxIN/RxOUT21	Blue4	B6	
	TxIN/RxOUT22	Blue5	B7 [MSB]	
	TxIN/RxOUT24	HSYNC	HSYNC	
	TxIN/RxOUT25	VSYNC	VSYNC	
	TxIN/RxOUT26	DEN	DEN	
TxOUT/RxIN3	TxIN/RxOUT27	Red6	R0 [LSB]	
	TxIN/RxOUT5	Red7 [MSB]	R1	
	TxIN/RxOUT10	Green6	G0 [LSB]	
	TxIN/RxOUT11	Green7 [MSB]	G1	
	TxIN/RxOUT16	Blue6	B0 [LSB]	
	TxIN/RxOUT17	Blue7 [MSB]	B1	
	TxIN/RxOUT23	Reserved	Reserved	



5.0 SIGNAL TIMING SPECIFICATION

5.1 Timing Parameters (DE only mode)

< Table 6. Timing Table >

ITEM	Symbol	Min	Typ	Max	Unit	Note
CLK	Period	t_{CLK}	11.8	13.3	17.9	ns
	Frequency	-	56	75.4	85.0	MHz
Hsync	Period	t_{HP}	1450	1560	2000	t_{CLK}
	Frequency	f_H	39.4	48.4	55	KHz
Vsync	Period	t_{VP}	778	806	1200	t_{HP}
	Frequency	f_V	47	60	65	Hz
Horizontal Active Display Term	Valid	t_{HV}	-	1366	-	t_{CLK}
	Total	t_{HP}	1450	1560	2000	t_{CLK}
Vertical Active Display Term	Valid	t_{VV}	-	768	-	t_{HP}
	Total	t_{VP}	778	806	1200	t_{HP}

Notes: This product is DE only mode. The input of Hsync & Vsync signal does not have an effect on normal operation.



5.2 Signal Timing Waveform

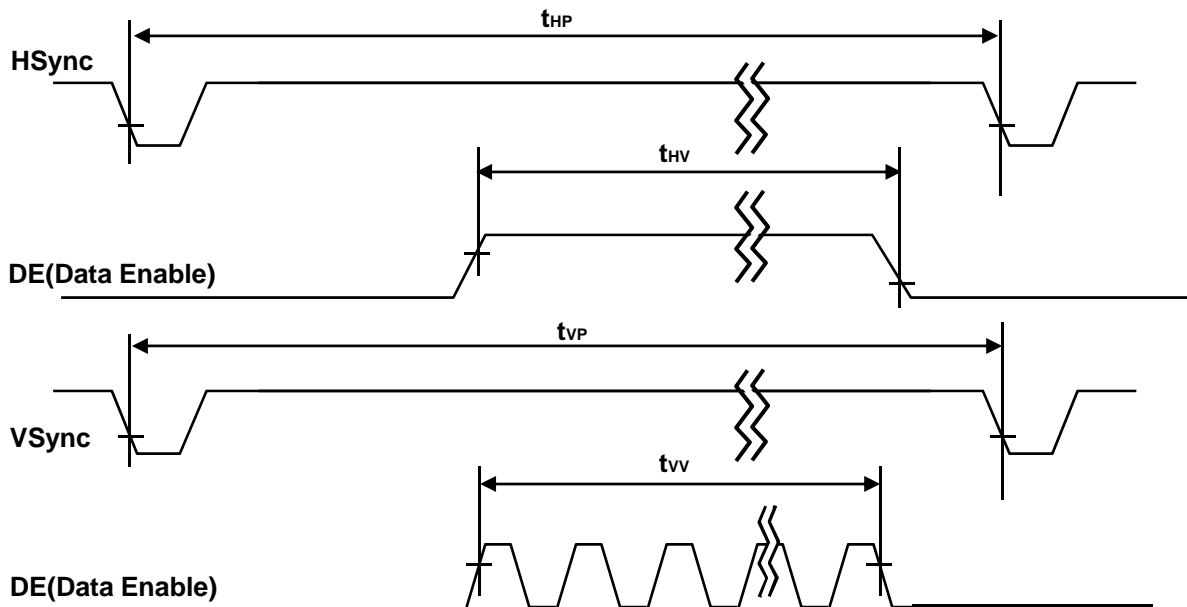
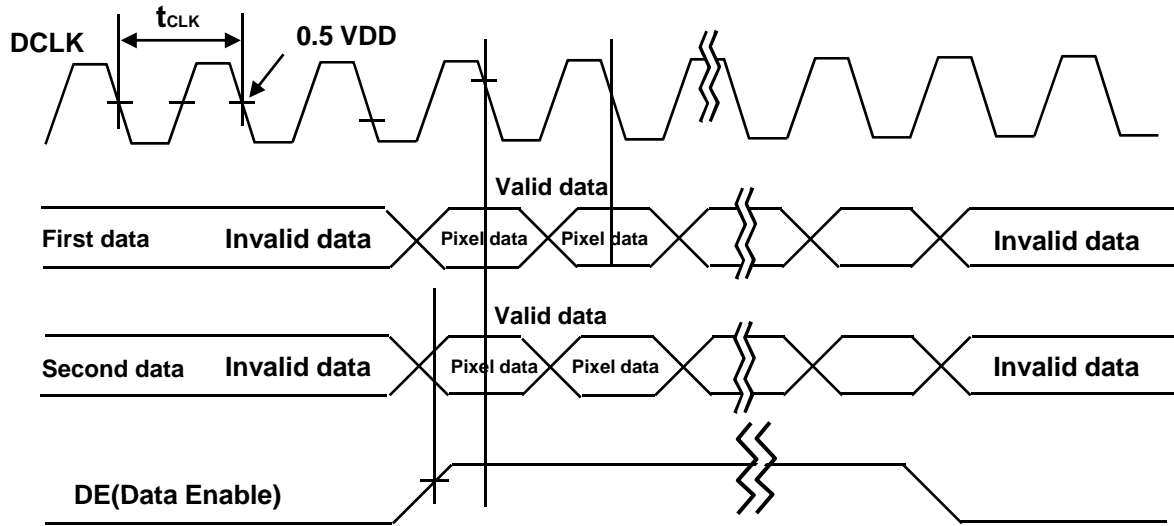



5.3 Input Signals, Basic Display Colors and Gray Scale of Colors

< Table 7. Input Signal and Display Color Table >

Color & Gray Scale		Input Data Signal																							
		Red Data						Green Data						Blue Data											
		R7	R6	R5	R4	R3	R2	R1	R0	G7	G6	G5	G4	G3	G2	G1	G0	B7	B6	B5	B4	B3	B2	B1	B0
Basic Colors	Black	0	0	0	0	0	0	0	0	0	0	0	0	0	0	0	0	0	0	0	0	0	0	0	0
	Blue	0	0	0	0	0	0	0	0	0	0	0	0	0	0	0	0	1	1	1	1	1	1	1	1
	Green	0	0	0	0	0	0	0	0	1	1	1	1	1	1	1	1	0	0	0	0	0	0	0	0
	Cyan	0	0	0	0	0	0	0	0	1	1	1	1	1	1	1	1	1	1	1	1	1	1	1	1
	Red	1	1	1	1	1	1	1	1	0	0	0	0	0	0	0	0	0	0	0	0	0	0	0	0
	Magenta	1	1	1	1	1	1	1	1	0	0	0	0	0	0	0	0	1	1	1	1	1	1	1	1
	Yellow	1	1	1	1	1	1	1	1	1	1	1	1	1	1	1	1	0	0	0	0	0	0	0	0
	White	1	1	1	1	1	1	1	1	1	1	1	1	1	1	1	1	1	1	1	1	1	1	1	1
Gray Scale of Red	Black	0	0	0	0	0	0	0	0	0	0	0	0	0	0	0	0	0	0	0	0	0	0	0	
	△	0	0	0	0	0	0	0	1	0	0	0	0	0	0	0	0	0	0	0	0	0	0	0	
	Darker	0	0	0	0	0	0	1	0	0	0	0	0	0	0	0	0	0	0	0	0	0	0	0	
	△	↑						↑						↑											
	▽	↓						↓						↓											
	Brighter	1	1	1	1	1	1	0	1	0	0	0	0	0	0	0	0	0	0	0	0	0	0	0	0
	▽	1	1	1	1	1	1	1	0	0	0	0	0	0	0	0	0	0	0	0	0	0	0	0	0
	Red	1	1	1	1	1	1	1	1	0	0	0	0	0	0	0	0	0	0	0	0	0	0	0	0
Gray Scale of Green	Black	0	0	0	0	0	0	0	0	0	0	0	0	0	0	0	0	0	0	0	0	0	0	0	
	△	0	0	0	0	0	0	0	0	0	0	0	0	0	0	0	1	0	0	0	0	0	0	0	
	Darker	0	0	0	0	0	0	0	0	0	0	0	0	0	0	1	0	0	0	0	0	0	0	0	
	△	↑						↑						↑											
	▽	↓						↓						↓											
	Brighter	0	0	0	0	0	0	0	0	1	1	1	1	1	1	0	1	0	0	0	0	0	0	0	0
	▽	0	0	0	0	0	0	0	0	1	1	1	1	1	1	1	0	0	0	0	0	0	0	0	0
	Green	0	0	0	0	0	0	0	0	1	1	1	1	1	1	1	1	0	0	0	0	0	0	0	0
Gray Scale of Blue	Black	0	0	0	0	0	0	0	0	0	0	0	0	0	0	0	0	0	0	0	0	0	0	0	
	△	0	0	0	0	0	0	0	0	0	0	0	0	0	0	0	0	0	0	0	0	0	0	1	
	Darker	0	0	0	0	0	0	0	0	0	0	0	0	0	0	0	0	0	0	0	0	0	0	1	
	△	↑						↑						↑											
	▽	↓						↓						↓											
	Brighter	0	0	0	0	0	0	0	0	0	0	0	0	0	0	0	0	1	1	1	1	1	1	0	1
	▽	0	0	0	0	0	0	0	0	0	0	0	0	0	0	0	0	1	1	1	1	1	1	1	0
	Blue	0	0	0	0	0	0	0	0	0	0	0	0	0	0	0	0	1	1	1	1	1	1	1	1
Gray Scale of White	Black	0	0	0	0	0	0	0	0	0	0	0	0	0	0	0	0	0	0	0	0	0	0	0	
	△	0	0	0	0	0	0	0	1	0	0	0	0	0	0	0	1	0	0	0	0	0	0	1	
	Darker	0	0	0	0	0	0	1	0	0	0	0	0	0	0	1	0	0	0	0	0	0	0	1	
	△	↑						↑						↑											
	▽	↓						↓						↓											
	Brighter	1	1	1	1	1	1	0	1	1	1	1	1	1	0	1	1	1	1	1	1	1	1	0	1
	▽	1	1	1	1	1	1	1	0	1	1	1	1	1	1	0	1	1	1	1	1	1	1	1	0
	White	1	1	1	1	1	1	1	1	1	1	1	1	1	1	1	1	1	1	1	1	1	1	1	1



5.4 Power Sequence

To prevent a latch-up or DC operation of the Open Cell, the power on/off sequence shall be as shown in below

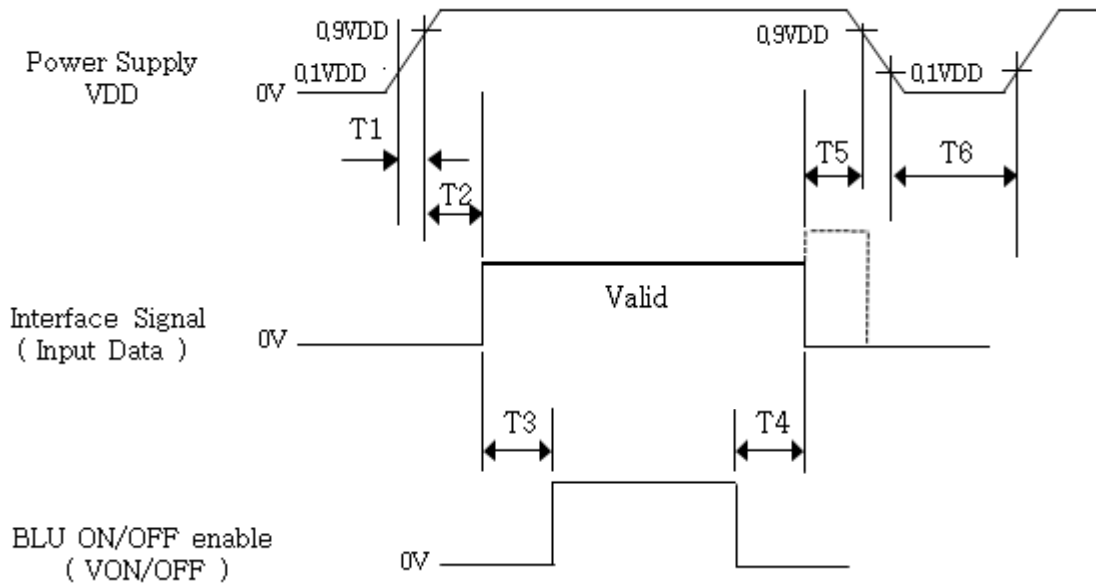

< Table 8. Sequence Table >

Parameter	Values			Units
	Min	Typ	Max	
T1	0.5	-	20	ms
T2	10	-	100	ms
T3	200	-	-	ms
T4	200	-	-	ms
T5	0	-	-	ms
T6	1	-	-	s

Notes: 1. Even though T1 is over the specified value, there is no problem if I2T spec of fuse is satisfied.

2. Please use differential oscilloscope test Interface Signal.

When using normal oscilloscope, If there is a action of pulling high in the valid Interface Signal wave, The end of Valid Interface Signal is at the point of pulling high, refer to the dotted line.

3. Back Light must be turn on after power for logic and interface signal are valid.



6.0 OPTICAL SPECIFICATIONS

The test of optical specifications shall be measured in a dark room (ambient luminance \leq 1 lux and temperature $=25\pm 2^{\circ}\text{C}$) with the equipment of Luminance meter system (Goniometer system and PR730) and test unit shall be located at an approximate distance 50cm from the LCD surface at a viewing angle of θ and Φ equal to 0° . We refer to $\theta_{\Phi=0}$ ($=\theta_3$) as the 3 o'clock direction (the "right"), $\theta_{\Phi=90}$ ($=\theta_{12}$) as the 12 o'clock direction ("upward"), $\theta_{\Phi=180}$ ($=\theta_9$) as the 9 o'clock direction ("left") and $\theta_{\Phi=270}$ ($=\theta_6$) as the 6 o'clock direction ("bottom"). While scanning θ and/or Φ , the center of the measuring spot on the Display surface shall stay fixed. The measurement shall be executed after 30 minutes warm-up period. VDD shall be 12.0V \pm 10% at 25°C . Optimum viewing angle direction is 6 'clock.

< Table 9. Optical Table >

[VDD = 12.0V, Frame rate = 60Hz, Ta = $25\pm 2^{\circ}\text{C}$]

Parameter		Symbol	Condition	Min	Typ	Max	Unit	Remark	
Viewing Angle	Horizontal	θ_3	CR > 10		89		Deg.	Note 1	
		θ_9			89		Deg.		
	Vertical	θ_{12}			89		Deg.		
		θ_6			89		Deg.		
Contrast Ratio		CR	$\theta = 0^{\circ}$ (Center) Normal Viewing Angle With BOE Module	900:1	1200:1	-		Note 2	
Response Time	G to G	T_g		-	8	10	ms	Note 3	
Gamma Scale					2.0	2.2	2.4		
Cell Transmittance						6.6		%	Note 4



Note :

1. Viewing angle is the angle at which the contrast ratio is greater than 10. The viewing are determined for the horizontal or 3, 9 o'clock direction and the vertical or 6, 12 o'clock direction with respect to the optical axis which is normal to the LCD surface.
2. Contrast measurements shall be made at viewing angle of $\theta = 0^\circ$ and at the center of the LCD surface. Luminance shall be measured with all pixels in the view field set first to white, then to the dark (black) state. (See Figure 1 shown in Appendix) Luminance Contrast Ratio (CR) is defined mathematically.

$$CR = \frac{\text{Luminance when displaying a white raster}}{\text{Luminance when displaying a black raster}}$$

3. Response time Tg is the average time required for display transition by switching the input signal as below table and is based on Frame rate fV =60Hz to optimize. Each time in below table is defined as Figure 2 and shall be measured by switching the input signal for "any level of gray(bright)" and "any level of gray(dark)".

Measured Response Time	Target																
	0	15	31	47	63	79	95	111	127	143	159	175	191	207	223	239	255
0																	
15																	
31																	
47																	
63																	
79																	
95																	
111																	
127																	
143																	
159																	
175																	
191																	
207																	
223																	
239																	
255																	

4. Definition of Transmittance (T%) :

Module is with white(L255) signal input

$$\text{Transmittance} = \frac{\text{Luminance of LCD Module}}{\text{Luminance of BLU}} \times 100 \%$$



7.0 MECHANICAL CHARACTERISTICS

7.1 Dimensional Requirements

Figure 3 (located in Appendix) shows mechanical outlines for the model HV320WX2-201. Other parameters are shown in Table 10.

< Table 10. Dimensional Parameters >

Parameter	Specification	Unit
Active area	697.685 (H) × 392.256(V)	mm
Pixel pitch	0.51(H) × 0.51(V)	mm
Number of pixels	1366(H) × 768(V) (1 pixel = R + G + B dots)	pixels
Weight	1160 (typ.)	gram

7.2 Semi-Glare and Polarizer Hardness

The surface of the LCD has an semi-glare coating to minimize reflection and a coating to reduce scratching.



8.0 Reliability Test Condition

< Table 12. Reliability Test Condition >

Test Item	Test Condition
High Temperature Storage Test	Ta = 60 °C, 240 hrs
Low Temperature Storage Test	Ta = -20 °C, 240 hrs
High Temperature & High Humidity Operation Test	Ta = 50 °C, 80%RH, 240hrs
High Temperature Operation Test	Ta = 50 °C, 240hrs
Low Temperature Operation Test	Ta = 0 °C, 240hrs
Thermal Shock Test	Ta = -20 °C (0.5 hr) ↔ 60 °C (0.5 hr), 100 cycle

This test condition is based on BOE module.



京东方
BOE

PRODUCT GROUP

REV

ISSUE DATE

TFT LCD

0

2012.12.21

9.0 PRODCUT SERIAL NUMBER

HV320WX2-170



XXXXXXXXXXXXXXXXXXXX

Label size: 40mm*9mm

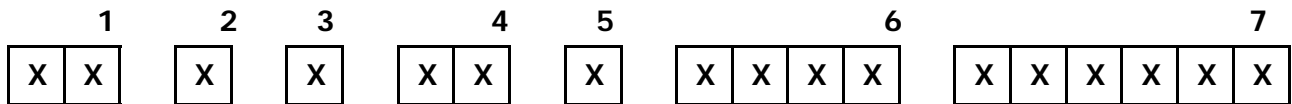

- 1. Control Number
- 2. Rank / Grade
- 3. Line Classification
- 4. Year (2011 : 11, 2012 : 12, ...)

- 5. Month (1,2,3, ... , 9, X, Y, Z)
- 6. Internal Use
- 7. Serial Number

SPEC. NUMBER
S8-64-8A-026

SPEC. TITLE
HV320WX2-170 Product Specification For LGE

PAGE
18 of 23



京东方
BOE

PRODUCT GROUP

TFT LCD

REV

0

ISSUE DATE

2012.12.21

10.0 PACKING INFORMATION

BOE provides the standard shipping container for customers, unless customer specifies their packing information. The standard packing method and Barcode information are shown in below.

10.1 Packing Order

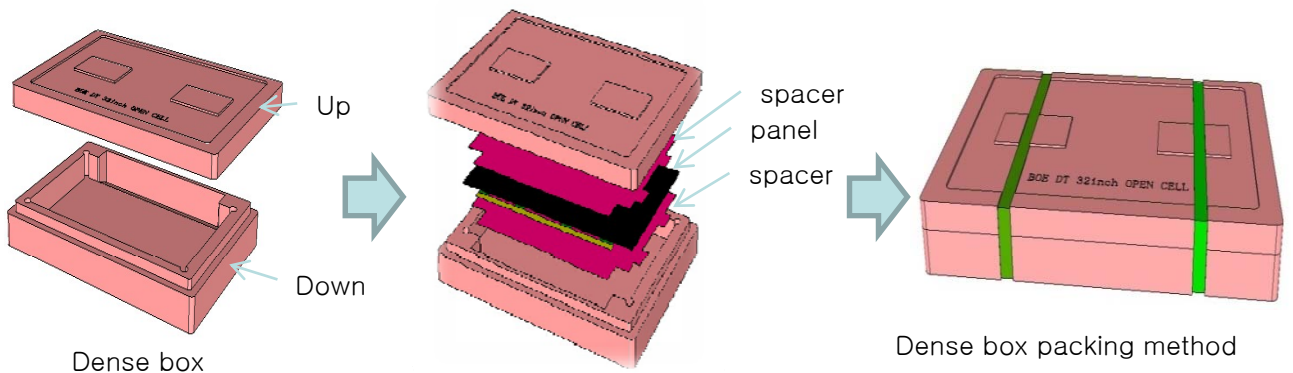

storage: spacer + panel + spacer+...+Panel + spacer

Total: spacer: 16 pcs
Panel: 15 pcs



SPEC. NUMBER
S8-64-8A-026

SPEC. TITLE
HV320WX2-170 Product Specification For LGE

PAGE
19 of 23



京东方
BOE

PRODUCT GROUP

REV

ISSUE DATE

TFT LCD

0

2012.12.21

10.2 Packing Note

- Box Dimension : 870mmL × 592mmW × 270mmH
- Package Quantity in one Box : 15 pcs

10.3 Box Label

- Label Size : 110 mm (L) × 55 mm (W)
- Contents

Model : HV320WX2-170

Q`ty : 15 Open Cell in one box.

Serial No. : Box Serial No. See next page for detail description.

Date : Packing Date

FG Code : FG Code of Product

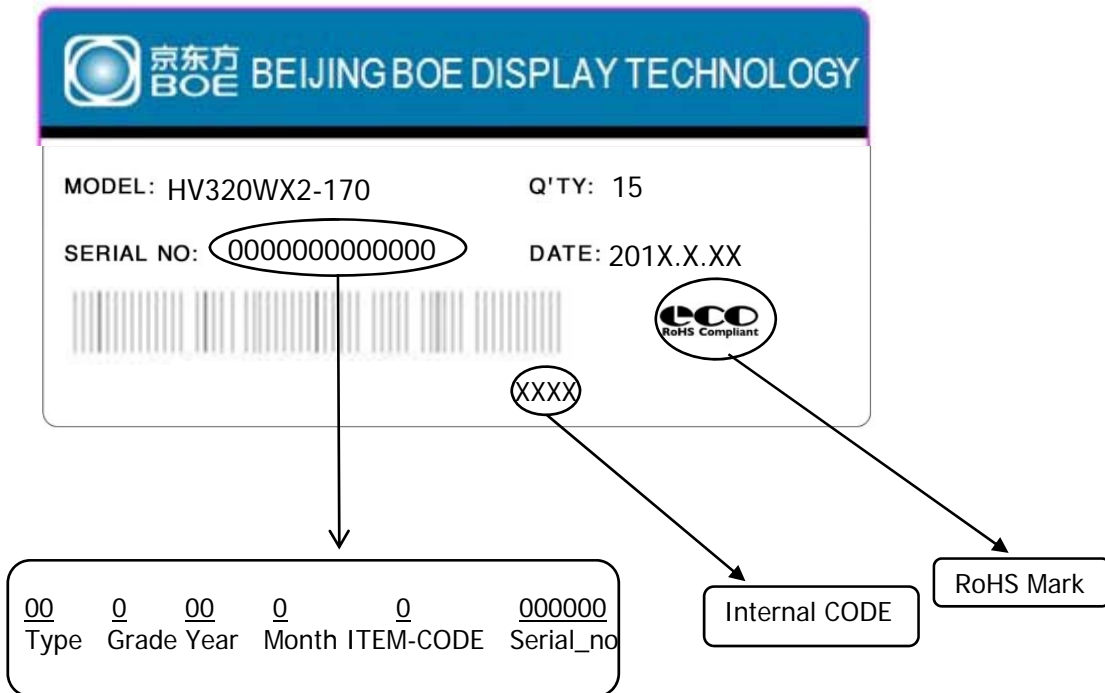

SPEC. NUMBER
S8-64-8A-026

SPEC. TITLE
HV320WX2-170 Product Specification For LGE

PAGE
20 of 23

 京东方 BOE	PRODUCT GROUP	REV	ISSUE DATE
	TFT LCD	0	2012.12.21

12.0 HANDLING & CAUTIONS

CAUTIONS

(1) Cautions when taking out the Panel

Pick the pouch only, when taking out panel from a shipping package.

(2) Cautions for handling the panel

As the electrostatic discharges may break the LCD Panel, handle the LCD panel with care. Peel a protection sheet off from the LCD panel surface as slowly as possible.

As the LCD panel and back -light element are made from fragile glass material, impulse and pressure to the LCD panel should be avoided.

As the surface of the polarizer is very soft and easily scratched, use a soft dry cloth without chemicals for cleaning.

Do not pull the interface connector in or out while the LCD panel is operating.

Put the panel display side down on a flat horizontal plane.

Handle connectors and cables with care.

(3) Cautions for the operation

When the panel is operating, do not lose CLK, ENAB signals. If any one of these signals is lost, the LCD panel would be damaged.

Obey the supply voltage sequence. If wrong sequence is applied, the panel would be damaged.

(4) Cautions for the atmosphere

Dew drop atmosphere should be avoided.

Do not store and/or operate the LCD panel in a high temperature and/or humidity atmosphere. Storage in an electro-conductive polymer packing pouch and under relatively low temperature atmosphere is recommended.

(5) Cautions for the panel characteristics

Do not apply fixed pattern data signal to the LCD panel at product aging.

Applying fixed pattern for a long time may cause image sticking.

(6) Other cautions

Do not disassemble and/or re-assemble LCD panel.

Do not re-adjust variable resistor or switch etc.

When returning the panel for repair or etc., Please pack the panel not to be broken. We recommend to use the original shipping packages.

SPEC. NUMBER S8-64-8A-026	SPEC. TITLE HV320WX2-170 Product Specification For LGE	PAGE 21 of 23
------------------------------	---	------------------



13.0 APPENDIX

< Figure 1. Measurement Set Up >

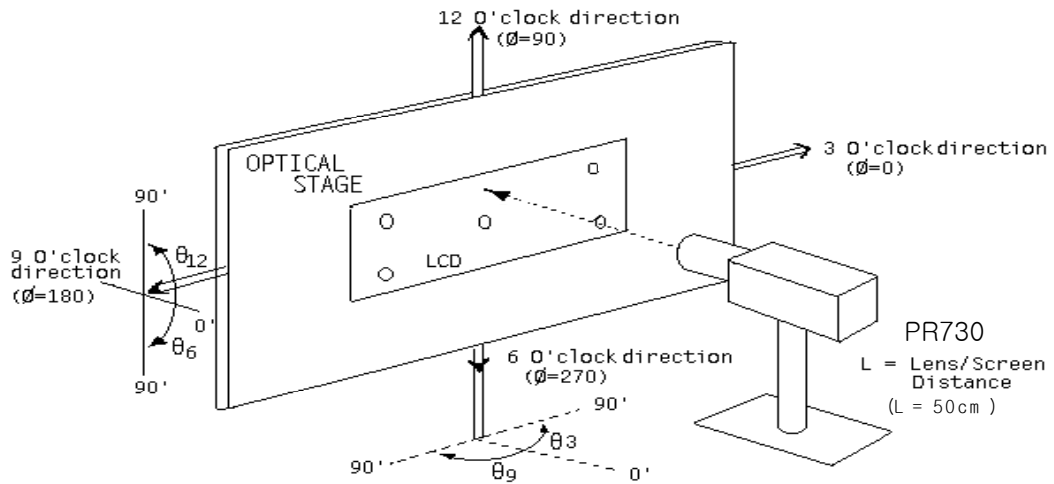

< Figure 2. Response Time Testing >

Any level of gray (Bright)

Any level of gray (Dark)

Any level of gray (Bright)

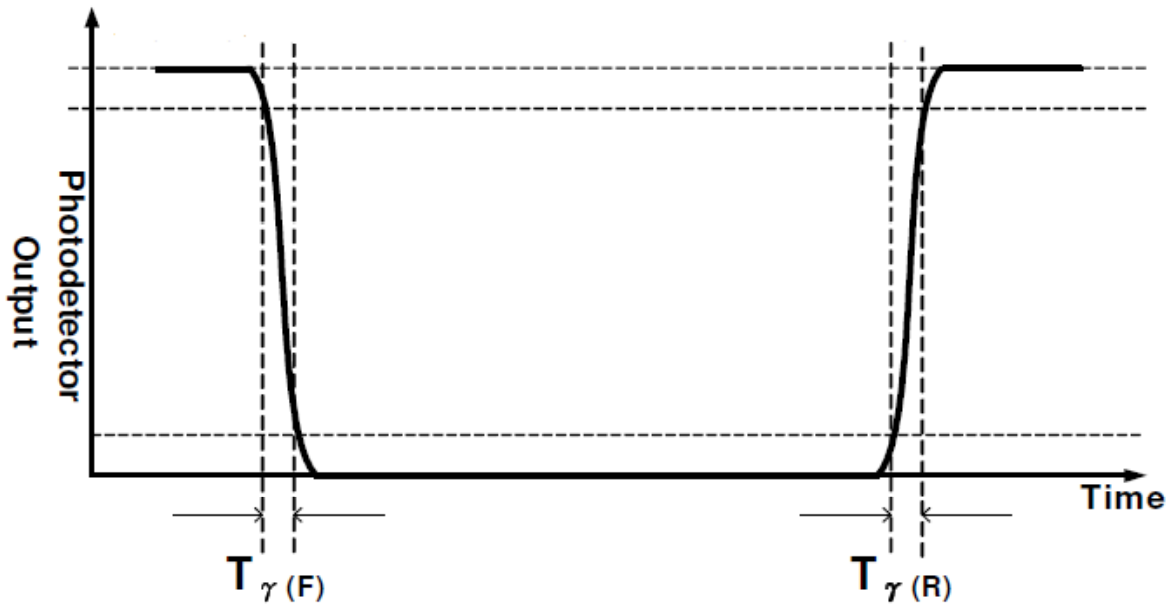



京东方
BOE

PRODUCT GROUP
TFT LCD

REV

ISSUE DATE

0

2012.12.21

< Figure 3. Open Cell Outline Dimensions (Front View) >

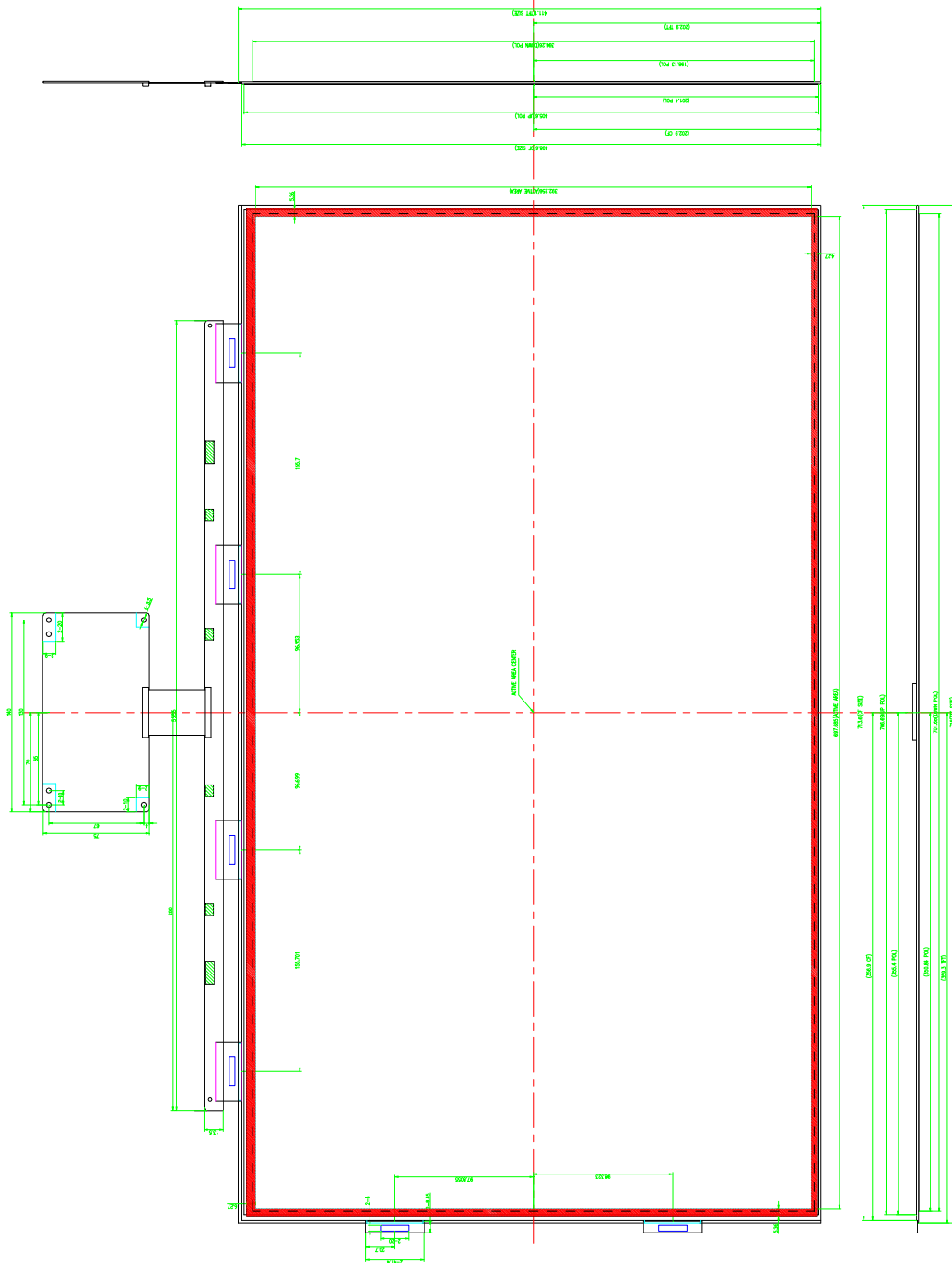

SPEC. NUMBER
S8-64-8A-026

SPEC. TITLE
HV320WX2-170 Product Specification For LGE

PAGE
23 of 23