

High-Voltage Ring Generator

Ordering Information

Operating Voltage	Package Options
$V_{PP1} - V_{NN1}$	44-Pin PLCC
220V	HV441PJ

Features

- 220V maximum operating voltage
- Integrated high voltage transistors
- Up to 70 V_{RMS} ring signal
- Adjustable AC and DC output voltage level
- Adjustable ring signal start phase angle
- Pulse by pulse output over current protection
- 5 REN output capability
- External MOSFETs enhance output rating to 20 REN

Applications

- Stand alone high voltage ring generator
- Set-top/Street box ring generator
- Pair gain ring generator
- Wireless local loops
- Fiber in the loop/to the curb
- Coax cable loop

Absolute Maximum Ratings

$V_{PP1} - V_{NN1}$, power supply voltage	+240V
V_{PP1} , positive high voltage supply	+120V
V_{PP2} , positive gate voltage supply	+120V
V_{NN1} , negative high voltage supply	-170V
V_{NN2} , negative gate voltage supply	-170V
V_{DD1} , low voltage logic supply	+7.5V
V_{DD2} , low voltage analog/logic supply	+18V
Storage temperature	-65°C to +150°C
Power dissipation	1200mW

General Description

The Supertex HV441 is a monolithic integrated circuit capable of generating up to a 70V RMS sine wave output at frequencies of 15Hz to 60Hz with a load of 5 North American RENs. Its output rating can be enhanced to 20 North American RENs with the addition of two Supertex MOSFETs: one N-Channel MOSFET, the TN2524N8 and one P-Channel MOSFET, the TP2522N8. The high voltage outputs have pulse by pulse over current protection set by two external sense resistors.

The HV441 generates a low voltage reference sine wave by using external passive components. An external sine wave signal can be used if desired. The HV441 amplifies the reference sine wave signal by pulse width modulating the high voltage output at a nominal frequency of 100KHz. An error amplifier compares the output sine wave with the reference sine wave and adjusts the pulse width accordingly. Both the amplitude of the output sine wave and the DC offset voltage are adjustable.

For detailed circuit and application information, please refer to application note AN-H35.

Electrical Characteristics

(Over operating supply voltage unless otherwise specified, $T_A = 25^\circ\text{C}$.)

Symbol	Parameters	Min	Typ	Max	Unit	Conditions
--------	------------	-----	-----	-----	------	------------

High Voltage Output

R_{SOURCE}	V_{OUT} P source resistance		55		Ω	$I_{\text{OUT}} = 100\text{mA}$
R_{SINK}	V_{OUT} P sink resistance		55		Ω	$I_{\text{OUT}} = -100\text{mA}$
DC_P	Max P-Channel duty cycle	92			%	$V_{\text{PP1}} = +60\text{V}$, $V_{\text{NN1}} = -160\text{V}$
DC_N	Max N-Channel duty cycle	94			%	$V_{\text{PP1}} = +60\text{V}$, $V_{\text{NN1}} = -160\text{V}$
$t_{\text{d(ON)}}$	HV _{OUT} delay time		150		ns	
t_{rise}	HV _{OUT} rise time			50	ns	
$t_{\text{d(OFF)}}$	HV _{OUT} delay time		200		ns	
t_{fall}	HV _{OUT} fall time			50	ns	
V_{psen}	HV _{OUT} current source sense voltage	$V_{\text{PP1}} - 0.75$	$V_{\text{PP1}} - 1.00$	$V_{\text{PP1}} - 1.25$	V	$T_A = -40^\circ\text{C}$ to $+85^\circ\text{C}$
		$V_{\text{PP1}} - 0.67$		$V_{\text{PP1}} - 1.31$		
V_{nsen}	HV _{OUT} current sink sense voltage	$V_{\text{NN1}} + 0.75$	$V_{\text{NN1}} + 1.00$	$V_{\text{NN1}} + 1.25$	V	$T_A = -40^\circ\text{C}$ to $+85^\circ\text{C}$
		$V_{\text{NN1}} + 0.65$		$V_{\text{NN1}} + 1.33$		
t_{shortP}	HV _{OUT} off delay time when current source sense is activated			100	ns	
t_{shortN}	HV _{OUT} off delay time when current sink sense is activated			100	ns	

Operational Amplifier 1, 2, and 3

Symbol	Parameters	Min	Typ	Max	Unit	Conditions
V_{OS}	Input offset voltage			5	mV	
I_{IN}	Input bias current			500	nA	
V_{IN}	Input voltage range	1		$V_{\text{DD2}} - 1$	V	
V_{OUT}	Output voltage swing	0.5		$V_{\text{DD2}} - 1$	V	
I_{SOURCE}	Output source current			3	mA	
I_{SINK}	Output sink current			-2.75	mA	
A_{O}	DC open loop gain	70	85		dB	
BW	Bandwidth	100			KHz	
SR	Output slew rate	0.3			V/ μs	

Comparator

Symbol	Parameters	Min	Typ	Max	Unit	Conditions
V_{OS}	Input offset voltage			4	mV	
I_{IN}	Input bias current			500	nA	
V_{IN}	Input voltage range			$V_{\text{DD2}} - 2$	V	
A_{V}	Voltage gain	80			dB	
t_{res}	Response time		80		ns	

Oscillator

Symbol	Parameters	Min	Typ	Max	Unit	Conditions
V_{osc1}	Input voltage range for osc1	0		V_{DD2}	V	
V_{osc2}	Input voltage range for osc2	0		V_{DD2}	V	
V_{oscin}	Input voltage range for oscin	0		V_{DD1}	V	
f_{oscout}	Output frequency of oscout			120	KHz	$f_{\text{OSC1}} = 480\text{KHz}$
V_{oscout}	Oscout voltage	0		V_{DD1}	V	

Electrical Characteristics, cont'd.

(Over operating supply voltage unless otherwise specified, $T_A = 25^\circ\text{C}$.)

Symbol	Parameters	Min	Typ	Max	Unit	Conditions
V_{PP1}	High voltage positive supply	15		110	V	$T_A = -40^\circ\text{C}$ to $+85^\circ\text{C}$
V_{PP2}	Positive charge pump output voltage	$V_{PP1} - 8$		$V_{PP1} - 19$	V	$T_A = -40^\circ\text{C}$ to $+85^\circ\text{C}$
V_{NN1}	High voltage negative supply	$V_{PP} - 220$		-110	V	$T_A = -40^\circ\text{C}$ to $+85^\circ\text{C}$
V_{NN2}	Negative charge pump output voltage	$V_{NN1} + 5.2$		$V_{NN1} + 10.5$	V	$T_A = -40^\circ\text{C}$ to $+85^\circ\text{C}$
V_{DD1}	Low voltage supply	3.0		5.5	V	$T_A = -40^\circ\text{C}$ to $+85^\circ\text{C}$
V_{DD2}	Low voltage supply	10.8		13.5	V	$T_A = -40^\circ\text{C}$ to $+85^\circ\text{C}$
I_{PP1Q}	V_{PP1} quiescent current		250	400	μA	$T_A = -40^\circ\text{C}$ to $+85^\circ\text{C}$
I_{NN1Q}	V_{NN1} quiescent current		250	500	μA	$T_A = -40^\circ\text{C}$ to $+85^\circ\text{C}$
I_{PP1}	V_{PP1} operating current			0.8	mA	HV _{OUT} switching at 100KHz, $V_{PP1} = +60\text{V}$, $V_{NN1} = -160\text{V}$, $T_A = -40^\circ\text{C}$ to $+85^\circ\text{C}$
I_{NN1}	V_{NN1} operating current			1.0	mA	
I_{DD1Q}	V_{DD1} quiescent current			10	μA	
I_{DD2Q}	V_{DD2} quiescent current			4.0	mA	

Pin Description

V_{PP1}	Positive high voltage supply
V_{PP2}	Positive gate voltage supply. Generated by an internal linear regulator.
V_{NN1}	Negative high voltage supply
V_{NN2}	Negative gate voltage supply. Generated by an internal linear regulator.
V_{DD1}	+3.3V to 5.0V supply for input and output logic
V_{DD2}	+12V supply for analog/logic circuit
GND	Low voltage ground
P_{GND}	High voltage power ground
Input1-	Inverting input of op-amp 1.
Input1+	Noninverting input of op-amp 1.
Output1	Output of op-amp 1.
Input2-	Inverting input of op-amp 2.
Input2+	Noninverting input of op-amp 2.
Output2	Output of op-amp 2.
Input3-	Inverting input of op-amp 3.
Input3+	Noninverting input of op-amp 3.
Output3	Output of op-amp 3.
V_{ref}	External input reference voltage for zero crossing detection.
On/Off	Enables/Disables HV _{OUT} .
osc1	Input 1 for external resonator. Connect to GND when not in use.
osc2	Input 2 for external resonator. Leave floating when not in use.
oscin	External oscillator input. Zero to V_{DD1} input signal. Connect to V_{DD1} when not in use.
oscout	Oscillator output; 1/4 frequency of external resonator. 50% duty cycle.
HV _{OUT}	High voltage output. Voltage swings from V_{PP1} to V_{NN1} .
V_{psen}	Pulse by pulse over current sensing for internal P-Channel MOSFET.
V_{nsen}	Pulse by pulse over current sensing for internal N-Channel MOSFET.
P_{gate}	Gate drive for external P-channel MOSFET.
Ngate	Gate drive for external N-channel MOSFET.

Functional Block Diagram

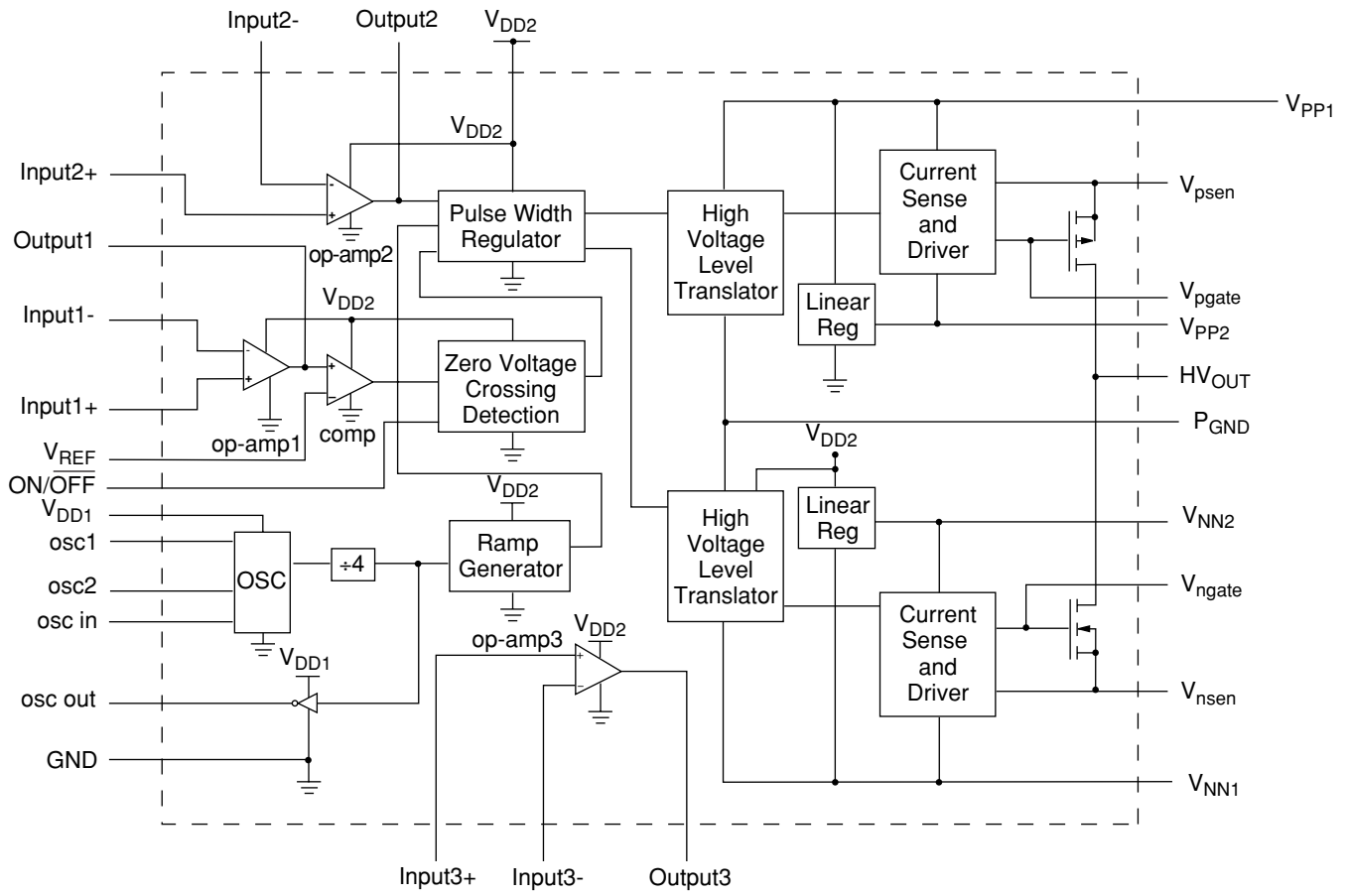

Typical 5 REN Application Circuit

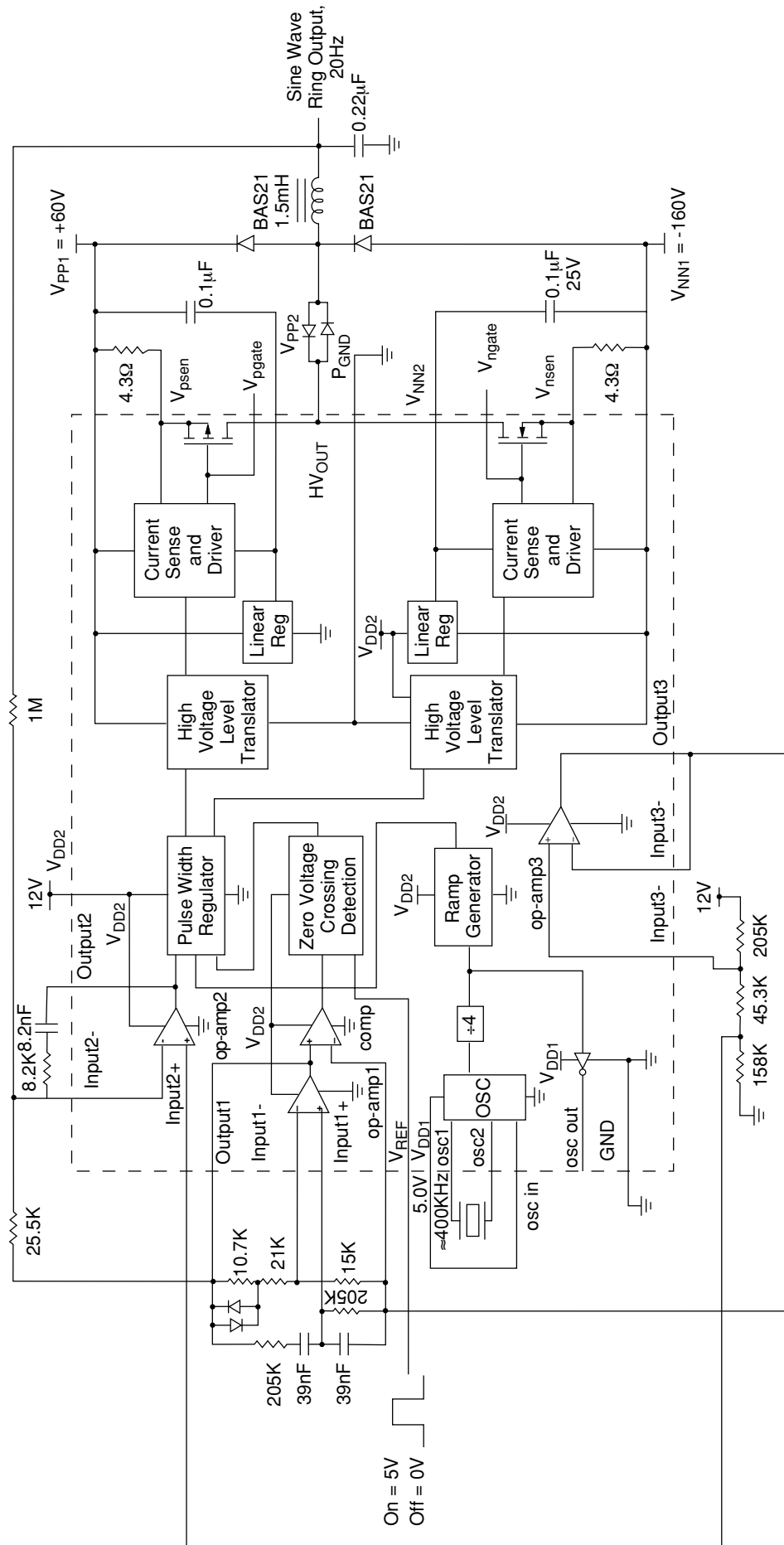

Typical 20 REN Application Circuit

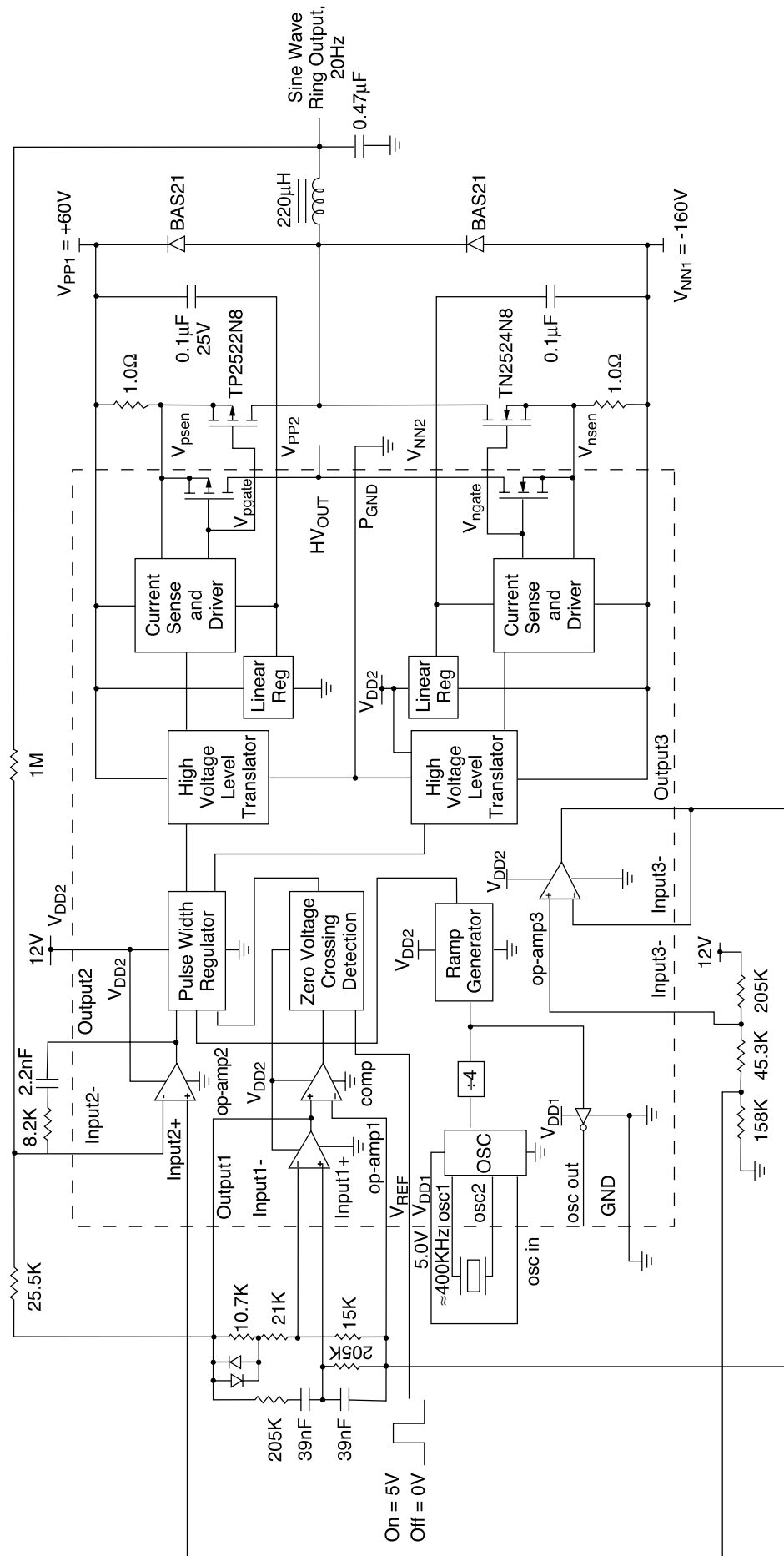

On = 5V
Off = 0V

Pin Configuration

Package Outline

HV441

Pin	Function	Pin	Function
1	N/C	23	HV _{OUT}
2	N/C	24	N/C
3	N/C	25	V _{psen}
4	V _{ref}	26	P _{gate}
5	N/C	27	V _{PP2}
6	V _{DD2}	28	N/C
7	N/C	29	V _{PP1}
8	V _{DD1}	30	N/C
9	osc1	31	N/C
10	osc2	32	N/C
11	oscin	33	P _{GND}
12	oscout	34	GND
13	ON/OFF	35	Output2
14	N/C	36	Input2-
15	N/C	37	Input2+
16	N/C	38	Output1
17	V _{NN1}	39	Input1-
18	N/C	40	Input1+
19	V _{NN2}	41	Output3
20	N _{gate}	42	Input3-
21	V _{rnsen}	43	Input3+
22	N/C	44	N/C

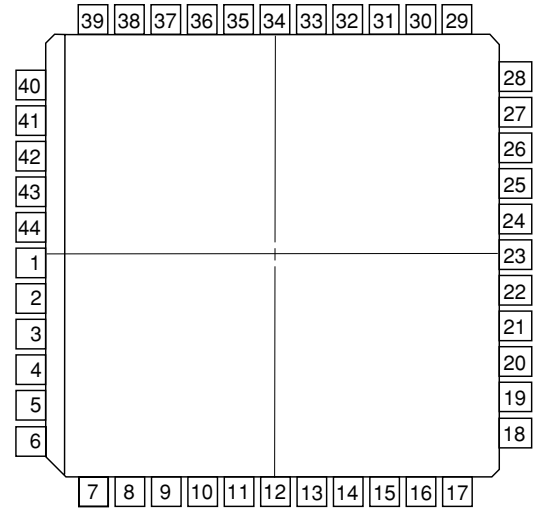

top view
44-pin PLCC