



PROPRIETARY NOTE

THIS SPECIFICATION IS THE PROPERTY OF BOE DT AND SHALL NOT BE REPRODUCED OR COPIED WITHOUT THE WRITTEN PERMISSION OF BOE DT AND MUST BE RETURNED TO BOE DT UPON ITS REQUEST

TITLE:

HV460WU2-200 Preliminary Product Specification

BEIJING BOE DISPLAY TECHNOLOGY

SPEC. NUMBER
S8XX-XXXX

PRODUCT GROUP
TFT LCD

REV.
P0

ISSUE DATE
2012.02.15

PAGE
1 of 24



京东方
BOE

PRODUCT GROUP

REV

ISSUE DATE

TFT LCD

P0

2012.02.15

Contents

No	ITEM	Page
	REVISIONS HISTORY	2
	CONTENTS	3
1	GENERAL DESCRIPTION	4
	1.1 Introduction	
	1.2 Features	
	1.3 Applications	
	1.4 General Specification	
2	ABSOLUTE MAXIMUM RATINGS	6
3	ELECTRICAL SPECIFICATIONS	7
	3.1 TFT LCD Open Cell	
4	INTERFACE CONNECTION	8
	4.1 Open Cell Input Signal & Power	
	4.2 LVDS Interface	
5	SIGNAL TIMING SPECIFICATIONS	11
	5.1 Timing Parameters	
	5.2 Signal Timing Waveform	
	5.3 Input Signals, Basic Display Colors & Cray Scale Of Colors	
	5.4 Power Sequence	
6	OPTICAL SPECIFICATIONS	15
7	MECHANICAL CHARACTERISTICS	17
8	RELIABLITY	18
9	PRODUCT SERIAL NUMBER	19
10	PACKING INFORMATION	20
11	HANDING & CAUTIONS	22
12	APPENDIX	23

SPEC. NUMBER
S8XX-XXXX

SPEC. TITLE
HV460WU2-200 Preliminary Product Specification

PAGE
3 of 24

1.0 GENERAL DESCRIPTION

1.1 Introduction

HV460WU2-200 is a color active matrix TFT LCD open cell using amorphous silicon TFT's (Thin Film Transistors) as an active switching devices. This module has a 46.00 inch diagonally measured active area with WUXGA resolutions (1920 horizontal by 1080 vertical pixel array). Each pixel is divided into RED, GREEN, BLUE dots which are arranged in vertical stripe and this module can display 16.7M colors. The TFT-LCD panel used for this module is adapted for a low reflection and higher color type.

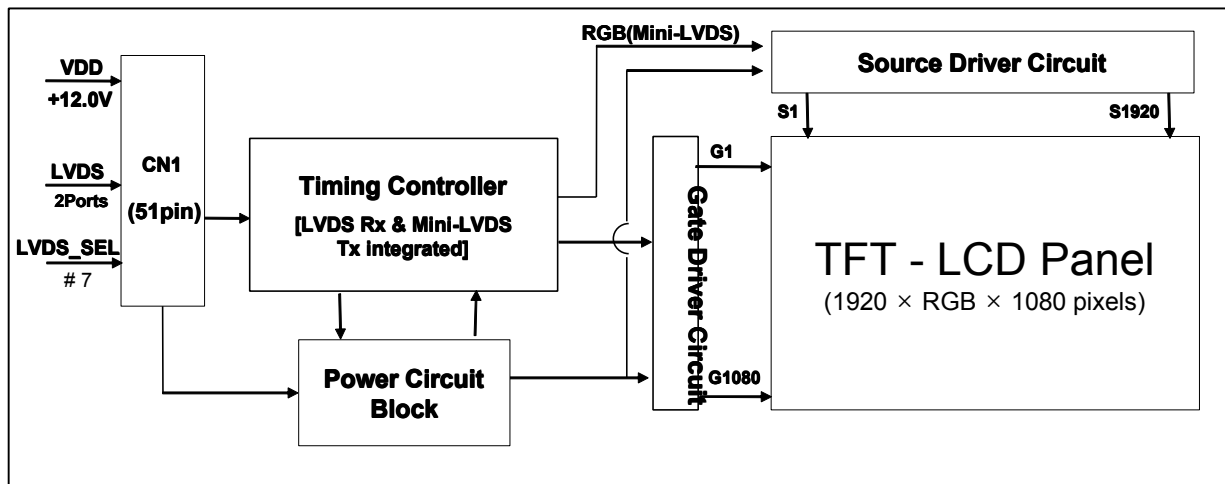

1.2 Features

- LVDS interface with 2 pixel / clock
- High-speed response
- Low color shift image quality
- 8-bit color depth, display 16.7M colors
- High luminance and contrast ratio, low reflection and wide viewing angle
- DE (Data Enable) only mode
- ADS technology is applied for high display quality
- RoHS compliant



京东方
BOE

PRODUCT GROUP

REV

ISSUE DATE

TFT LCD

P0

2012.02.15

1.3 Application

- Home Alone Multimedia TFT-LCD TV
- Display Terminals for Control System
- Full High Definition TV(FHD TV)
- AV application Products

1.4 General Specification

< Table 1. General Specifications >

Parameter	Specification	Unit	Remark
Active area	1018.08(H) × 572.67(V)	mm	
Number of pixels	1920(H) × 1080(V)	pixels	
Pixel pitch	176.75(H) × RGB × 530.25(V)	μm	
Pixel arrangement	Pixels RGB Vertical stripe		
Display colors	16.7M(8bits-true)	colors	
Display mode	Transmission mode, Normally Black		
Open Cell Transmittance	6.3 (typ.)	%	At center point with BOE BLU
Weight	2370 (Typ.)	gram	With T-con Board
Power Consumption	9.0(Typ.)	Watt	
Surface Treatment	Haze 13%, 3H, Anti-glare treatment (Front Polarizer) Clear (Bottom Polarizer)		

SPEC. NUMBER
S8XX-XXXX

SPEC. TITLE
HV460WU2-200 Preliminary Product Specification

PAGE
5 of 24

2.0 ABSOLUTE MAXIMUM RATINGS

The followings are maximum values which, if exceed, may cause faulty operation or damage to the unit. The operational and non-operational maximum voltage and current values are listed in Table 2.

< Table 2. Open Cell Electrical Specifications >

[VSS=GND=0V]

Parameter	Symbol	Min.	Max.	Unit	Remark
Power Supply Voltage	VDD	VSS-0.3	13.5	V	Ta = 25 °C
Operating Temperature	T _{OP}	0	+50	°C	Note 1
	T _{SUR}	0	+60	°C	
Storage Temperature	T _{ST}	-20	+60	°C	
Operating Ambient Humidity	Hop	10	80	%RH	
Storage Humidity	Hst	10	80	%RH	

Note 1 : Temperature and relative humidity range are shown in the figure below.

Wet bulb temperature should be 39 °C max. and no condensation of water.

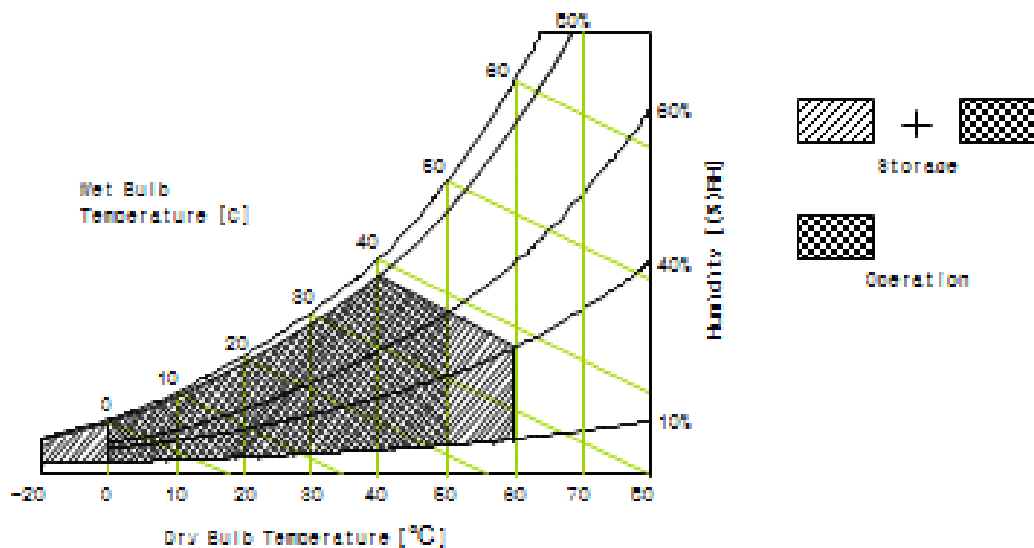

3.0 ELECTRICAL SPECIFICATIONS

3.1 TFT LCD open cell

< Table 3. Open Cell Electrical Specifications >

[Ta =25±2 ℃]

Parameter		Symbol	Values			Unit	Remark
			Min	Typ	Max		
Power Supply Input Voltage		VDD	10.8	12	13.2	Vdc	
Power Supply Ripple Voltage		VRP			300	mV	
Power Supply Current		IDD	-	750	850	mA	Note 1
Power Consumption		PDD		9.0	10.2	Watt	
Rush current		IRUSH	-	-	3.0	A	Note 2
LVDS Interface	Differential Input High Threshold Voltage	VLVTH	+100		+300	mV	
	Differential Input Low Threshold Voltage	VLVTL	-300		-100	mV	
	Common Input Voltage	VLVC	1.0	1.2	1.4	V	
CMOS Interface	Input High Threshold Voltage	VIH	2.7	-	3.3	V	
	Input Low Threshold Voltage	VIL	0	-	0.6	V	

Note 1 : The supply voltage is measured and specified at the interface connector of LCM.

The current draw and power consumption specified is for VDD= 12.0V,
Frame rate $f_v=60\text{Hz}$ and Clock frequency = 75.4MHz.

Test Pattern of power supply current

a) Typ : Color Test (L0/L255)

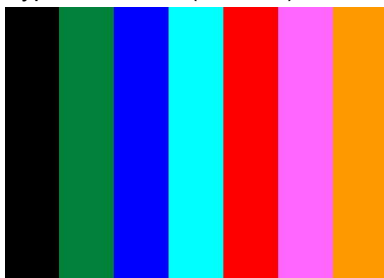

b) Max : Vertical Subline (L0/L255)

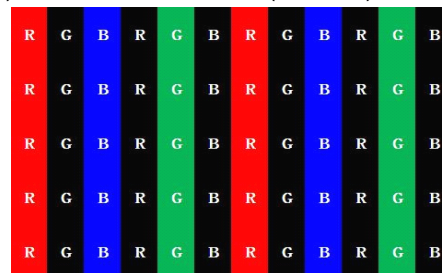

Note 2 : The duration of rush current is about 2ms and rising time of Power Input is 1ms(min)

SPEC. NUMBER
S8XX-XXXX

SPEC. TITLE
HV460WU2-200 Preliminary Product Specification

PAGE
7 of 24



4.0 INTERFACE CONNECTION

4.1 Module Input Signal & Power

- Connector : IS100-L30B-C23(Manufactured by UJU) or Equivalent.

< Table 4. Open Cell Input Connector Pin Configuration >

Pin No	Symbol	Description	Pin No	Symbol	Description
1	NC	No Connection	21	GND	Ground
2	SDA	I ² C Data	22	CH1[3]-	First pixel negative LVDS differential data input. Pair3
3	SCL	I ² C Clock	23	CH1[3]+	First pixel positive LVDS differential data input. Pair3
4	NC	Not Connected	24	CH1[4]-/NC	First pixel negative LVDS differential data input. Pair4
5	NC	Not Connected	25	CH1[4]+/NC	First pixel positive LVDS differential data input. Pair4
6	NC	Not Connected	26	NC	Not Connected
7	SELLVDS	High : JEIDA Low or Open:NS	27	NC	Not Connected
8	NC	Not Connected	28	CH2[0]-	Second pixel negative LVDS differential data input. Pair0
9	NC	Not Connected	29	CH2[0]+	Second pixel positive LVDS differential data input. Pair0
10	NC	Not Connected	30	CH2[1]-	Second pixel negative LVDS differential data input. Pair1
11	GND	Ground	31	CH2[1]+	Second pixel positive LVDS differential data input. Pair1
12	CH1[0]-	First pixel negative LVDS differential data input. Pair0	32	CH2[2]-	Second pixel negative LVDS differential data input. Pair2
13	CH1[0]+	First pixel positive LVDS differential data input. Pair0	33	CH2[2]+	Second pixel positive LVDS differential data input. Pair2
14	CH1[1]-	First pixel negative LVDS differential data input. Pair1	34	GND	Ground
15	CH1[1]+	First pixel positive LVDS differential data input. Pair1	35	CH2CLK-	First pixel negative LVDS clock
16	CH1[2]-	First pixel negative LVDS differential data input. Pair2	36	CH2CLK+	First pixel positive LVDS clock
17	CH1[2]+	First pixel positive LVDS differential data input. Pair2	37	GND	Ground
18	GND	Ground	38	CH2[3]-	Second pixel negative LVDS differential data input. Pair3
19	CH1CLK-	First pixel negative LVDS clock	39	CH2[3]+	Second pixel positive LVDS differential data input. Pair3
20	CH1CLK+	First pixel positive LVDS clock			



京东方
BOE

PRODUCT GROUP

REV

ISSUE DATE

TFT LCD

P0

2012.02.15

Pin No	Symbol	Description	Pin No	Symbol	Description
40	CH2[4]-/NC	Second pixel negative LVDS differential data input. Pair4	46	GND	Ground
41	CH2[4]+/NC	Second pixel positive LVDS differential data input. Pair4	47	NC	Not Connected
42	NC	Not Connected	48	VCC	Input Voltage
43	NC	Not Connected	49	VCC	Input Voltage
44	GND	Ground	50	VCC	Input Voltage
45	GND	Ground	51	VCC	Input Voltage

- Notes :
1. NC(Not Connected) : This pins are only used for BOE internal operations .
 2. Input Level of LVDS signal is based on the IEA 664 Standard.
 3. LVDS_SEL : This pin is used for selecting LVDS signal data format.
If this Pin : High (3.3V) or Open (NC) → Normal NS LVDS format
Otherwise : Low (GND) → JEIDA LVDS format

Rear view of LCM

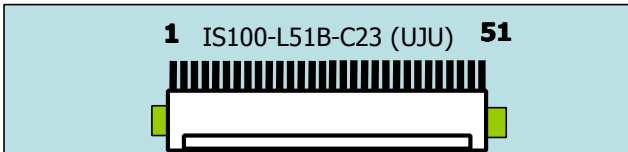

BIST Pattern

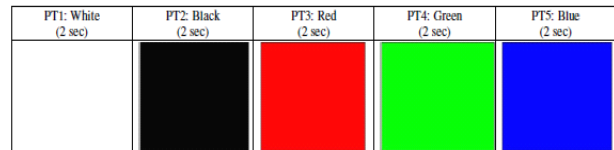

SPEC. NUMBER
S8XX-XXXX

SPEC. TITLE
HV460WU2-200 Preliminary Product Specification

PAGE
9 of 24



京东方
BOE

PRODUCT GROUP

REV

ISSUE DATE

TFT LCD

P0

2012.02.15

4.2 LVDS Interface

- LVDS Receiver : Timing Controller (LVDS Rx merged) / LVDS Data : Pixel Data

< Table 5. Open Cell Input Connector Pin Configuration >

Channel No.	Data No.	8-bit LVDS Type	
		NS	JEIDA
0	Bit-0	R0	R2
	Bit-1	R1	R3
	Bit-2	R2	R4
	Bit-3	R3	R5
	Bit-4	R4	R6
	Bit-5	R5	R7
	Bit-6	G0	G2
1	Bit-0	G1	G3
	Bit-1	G2	G4
	Bit-2	G3	G5
	Bit-3	G4	G6
	Bit-4	G5	G7
	Bit-5	B0	B2
	Bit-6	B1	B3
2	Bit-0	B2	B4
	Bit-1	B3	B5
	Bit-2	B4	B6
	Bit-3	B5	B7
	Bit-4	HS	HS
	Bit-5	VS	VS
	Bit-6	DE	DE
3	Bit-0	R6	R0
	Bit-1	R7	R1
	Bit-2	G6	G0
	Bit-3	G7	G1
	Bit-4	B6	B0
	Bit-5	B7	B1
	Bit-6	-	

SPEC. NUMBER
S8XX-XXXX

SPEC. TITLE
HV460WU2-200 Preliminary Product Specification

PAGE
10 of 24



5.0 SIGNAL TIMING SPECIFICATION

5.1 Timing Parameters (DE only mode)

< Table 6. Timing Table >

Item		Symbols	Min	Typ	Max	Unit
Clock	Frequency	1/Tc	66.00	74.25	82	MHz
	High Time	Tch	-	4/7Tc	-	
	Low Time	Tcl	-	4/7Tc	-	
Frame Period		Tv	1116	1126	1150	lines
			56.32	60	62.77	Hz
Vertical Display Period		Tvd	-	1080	-	lines
One line Scanning Period		Th	1050	1100	1150	clocks
Horizontal Display Period		Thd	960	960	960	clocks

Notes: This product is DE only mode. The input of Hsync & Vsync signal does not have an effect on normal operation.

5.2 Signal Timing Waveform

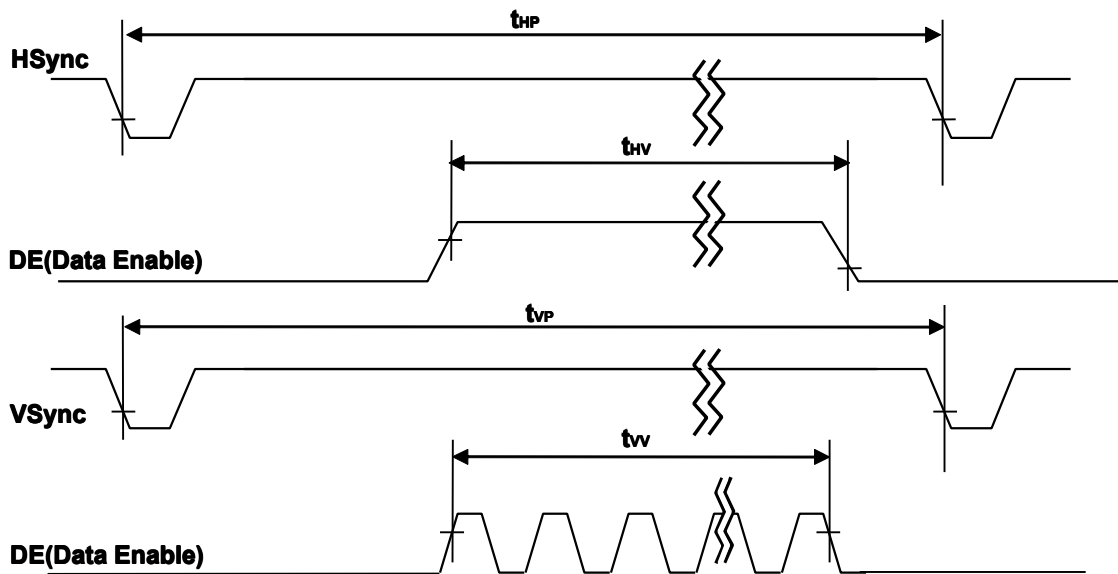
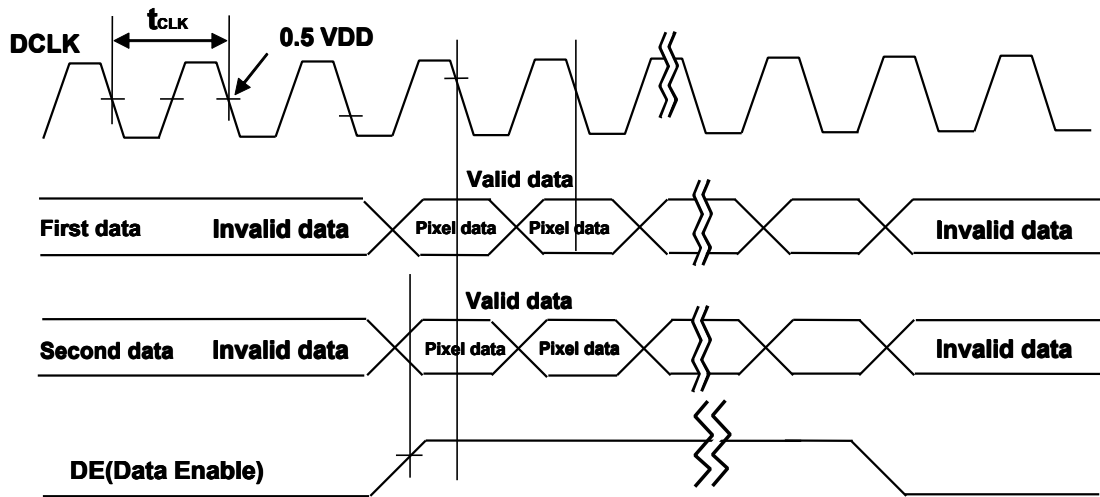

5.3 Input Signals, Basic Display Colors and Gray Scale of Colors

< Table 7. Input Signal and Display Color Table >

Color & Gray Scale		Input Data Signal																							
		Red Data								Green Data								Blue Data							
		R7	R6	R5	R4	R3	R2	R1	R0	G7	G6	G5	G4	G3	G2	G1	G0	B7	B6	B5	B4	B3	B2	B1	B0
Basic Colors	Black	0	0	0	0	0	0	0	0	0	0	0	0	0	0	0	0	0	0	0	0	0	0	0	0
	Blue	0	0	0	0	0	0	0	0	0	0	0	0	0	0	0	0	1	1	1	1	1	1	1	1
	Green	0	0	0	0	0	0	0	0	1	1	1	1	1	1	1	1	0	0	0	0	0	0	0	0
	Cyan	0	0	0	0	0	0	0	0	1	1	1	1	1	1	1	1	1	1	1	1	1	1	1	1
	Red	1	1	1	1	1	1	1	1	0	0	0	0	0	0	0	0	0	0	0	0	0	0	0	0
	Magenta	1	1	1	1	1	1	1	1	0	0	0	0	0	0	0	0	1	1	1	1	1	1	1	1
	Yellow	1	1	1	1	1	1	1	1	1	1	1	1	1	1	1	1	0	0	0	0	0	0	0	0
	White	1	1	1	1	1	1	1	1	1	1	1	1	1	1	1	1	1	1	1	1	1	1	1	1
Gray Scale of Red	Black	0	0	0	0	0	0	0	0	0	0	0	0	0	0	0	0	0	0	0	0	0	0	0	
	△	0	0	0	0	0	0	0	1	0	0	0	0	0	0	0	0	0	0	0	0	0	0	0	
	Darker	0	0	0	0	0	0	1	0	0	0	0	0	0	0	0	0	0	0	0	0	0	0	0	
	△	↑								↑															
	▽	↓								↓															
	Brighter	1	1	1	1	1	1	0	1	0	0	0	0	0	0	0	0	0	0	0	0	0	0	0	0
	▽	1	1	1	1	1	1	1	0	0	0	0	0	0	0	0	0	0	0	0	0	0	0	0	0
	Red	1	1	1	1	1	1	1	1	0	0	0	0	0	0	0	0	0	0	0	0	0	0	0	0
Gray Scale of Green	Black	0	0	0	0	0	0	0	0	0	0	0	0	0	0	0	0	0	0	0	0	0	0	0	
	△	0	0	0	0	0	0	0	0	0	0	0	0	0	0	0	1	0	0	0	0	0	0	0	
	Darker	0	0	0	0	0	0	0	0	0	0	0	0	0	0	1	0	0	0	0	0	0	0	0	
	△	↑								↑															
	▽	↓								↓															
	Brighter	0	0	0	0	0	0	0	0	1	1	1	1	1	1	0	1	0	0	0	0	0	0	0	0
	▽	0	0	0	0	0	0	0	0	1	1	1	1	1	1	0	0	0	0	0	0	0	0	0	0
	Green	0	0	0	0	0	0	0	0	1	1	1	1	1	1	1	0	0	0	0	0	0	0	0	0
Gray Scale of Blue	Black	0	0	0	0	0	0	0	0	0	0	0	0	0	0	0	0	0	0	0	0	0	0	0	
	△	0	0	0	0	0	0	0	0	0	0	0	0	0	0	0	0	0	0	0	0	0	0	1	
	Darker	0	0	0	0	0	0	0	0	0	0	0	0	0	0	0	0	0	0	0	0	0	0	1	
	△	↑								↑															
	▽	↓								↓															
	Brighter	0	0	0	0	0	0	0	0	0	0	0	0	0	0	0	1	1	1	1	1	1	0	1	
	▽	0	0	0	0	0	0	0	0	0	0	0	0	0	0	0	1	1	1	1	1	1	1	0	
	Blue	0	0	0	0	0	0	0	0	0	0	0	0	0	0	0	1	1	1	1	1	1	1	1	
Gray Scale of White	Black	0	0	0	0	0	0	0	0	0	0	0	0	0	0	0	0	0	0	0	0	0	0	0	
	△	0	0	0	0	0	0	0	1	0	0	0	0	0	0	0	1	0	0	0	0	0	0	1	
	Darker	0	0	0	0	0	0	1	0	0	0	0	0	0	1	0	0	0	0	0	0	0	1	0	
	△	↑								↑															
	▽	↓								↓															
	Brighter	1	1	1	1	1	1	0	1	1	1	1	1	1	0	1	1	1	1	1	1	1	0	1	
	▽	1	1	1	1	1	1	1	0	1	1	1	1	1	1	0	1	1	1	1	1	1	1	0	
	White	1	1	1	1	1	1	1	1	1	1	1	1	1	1	1	1	1	1	1	1	1	1	1	



5.4 Power Sequence

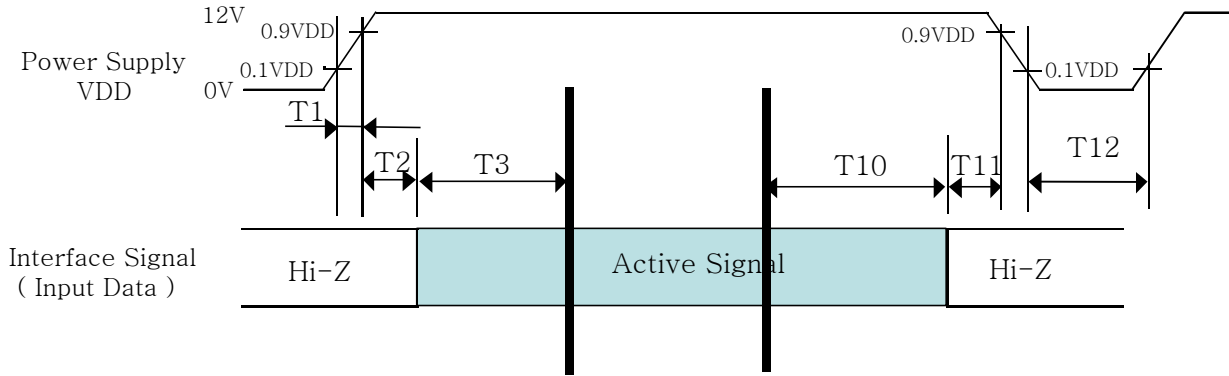

< Table 8. Sequence Table >

Parameter	Values			Units
	Min	Typ	Max	
T1	0.5	-	10	ms
T2	0	-	50	ms
T3	200	-	-	ms
T10	200	-	-	ms
T11	0	-	50	ms
T12	1	-	-	s

Notes: 1. Even though T1 is over the specified value, there is no problem if I2T spec of fuse is satisfied.



6.0 OPTICAL SPECIFICATIONS

The test of optical specifications shall be measured in a dark room (ambient luminance ≤ 1 lux and temperature $= 25 \pm 2^\circ\text{C}$) with the equipment of Luminance meter system (Goniometer system and PR730) and test unit shall be located at an approximate distance 50cm from the LCD surface at a viewing angle of θ and Φ equal to 0° . We refer to $\theta_{-\phi=0}$ ($=\theta_3$) as the 3 o'clock direction (the "right"), $\theta_{-\phi=90}$ ($=\theta_{12}$) as the 12 o'clock direction ("upward"), $\theta_{-\phi=180}$ ($=\theta_9$) as the 9 o'clock direction ("left") and $\theta_{-\phi=270}$ ($=\theta_6$) as the 6 o'clock direction ("bottom"). While scanning θ and/or ϕ , the center of the measuring spot on the Display surface shall stay fixed. The measurement shall be executed after 30 minutes warm-up period. VDD shall be 12.0V +/-10% at 25°C . Optimum viewing angle direction is 6 'clock.

< Table 9. Optical Table >

[VDD = 12.0V, Frame rate = 60Hz, Ta = $25 \pm 2^\circ\text{C}$]

Parameter	Symbol	Condition	Min	Typ	Max	Unit	Remark
Viewing Angle	Horizontal	CR > 10		89		Deg.	Note 1
				89			
	Vertical			89			
				89			
Contrast ratio		CR	900:1	1200:1	-		Note 2
Reproduction of color	White	$\Theta = 0^\circ$ (Center) Normal Viewing Angle	TYP. - 0.03	0.280	TYP. + 0.03		Note 3
				0.290			
	Red			TBD			
				TBD			
	Green			TBD			
				TBD			
	Blue			TBD			
				TBD			
Response Time	G to G	T_g	-	8	10	ms	Note 4
Gamma Scale			2.0	2.2	2.4		
Cell Transmittance				6.3		%	Note 5



京东方
BOE

PRODUCT GROUP

REV

ISSUE DATE

TFT LCD

P0

2012.02.15

Note :

1. Viewing angle is the angle at which the contrast ratio is greater than 10. The viewing are determined for the horizontal or 3, 9 o'clock direction and the vertical or 6, 12 o'clock direction with respect to the optical axis which is normal to the LCD surface.
2. Contrast measurements shall be made at viewing angle of $\theta = 0^\circ$ and at the center of the LCD surface. Luminance shall be measured with all pixels in the view field set first to white, then to the dark (black) state. (See Figure 1 shown in Appendix) Luminance Contrast Ratio (CR) is defined mathematically.

$$CR = \frac{\text{Luminance when displaying a white raster}}{\text{Luminance when displaying a black raster}}$$

3. The color chromaticity coordinates specified in Table 9 shall be calculated from the spectral data measured with all pixels first in red, green, blue and white. Measurements shall be made at the center of the panel.
4. Response time T_g is the average time required for display transition by switching the input signal as below table and is based on Frame rate $f_V = 60\text{Hz}$ to optimize. Each time in below table is defined as Figure 2 and shall be measured by switching the

Measured Response Time	Target																
	0	15	31	47	63	79	95	111	127	143	159	175	191	207	223	239	255
0																	
15																	
31																	
47																	
63																	
79																	
95																	
111																	
127																	
143																	
159																	
175																	
191																	
207																	
223																	
239																	
255																	

5. Definition of Transmittance (T%) :

Module is with white(L255) signal input

$$\text{Transmittance} = \frac{\text{Luminance of LCD Module}}{\text{Luminance of BLU}} \times 100 \%$$

SPEC. NUMBER
S8XX-XXXX

SPEC. TITLE
HV460WU2-200 Preliminary Product Specification

PAGE
16 of 24



7.0 MECHANICAL CHARACTERISTICS

7.1 Dimensional Requirements

Figure 3(located in Appendix) shows mechanical outlines for the model HV460WU2-200. Other parameters are shown in Table 10.

< Table 10. Dimensional Parameters >

Parameter	Specification	Unit
Active area	1018.08 (H) × 572.67(V)	mm
Pixel pitch	0.53025(H) × 0.53025(V)	mm
Number of pixels	1920(H) × 1080(V) (1 pixel = R + G + B dots)	pixels
Weight	2370 (Typ.)	gram

7.2 Semi-Glare and Polarizer Hardness

The surface of the LCD has an Anti-glare coating to minimize reflection and a coating to Reduce scratching.



8.0 RELIABILITY TEST

The Reliability test items and its conditions are shown in below.

< Table 11. Reliability Test Parameters >

No	Test Items	Conditions
1	High temperature storage test	Ta = 60 °C, 240 hrs
2	Low temperature storage test	Ta = -20 °C, 240 hrs
3	High temperature & high humidity operation test	Ta = 50 °C, 80%RH, 240hrs
4	High temperature operation test	Ta = 50 °C, 240hrs
5	Low temperature operation test	Ta = 0 °C, 240hrs
6	Thermal shock	Ta = -20 °C ↔ 60 °C (0.5 hr), 100 cycle
7	Vibration test (non-operating)	Frequency : 10 ~ 300 Hz, Random Gravity / AMP : 1.0 Grms Period : X, Y, Z 30 min/axis
8	Shock test (non-operating)	Gravity : 50G Pulse width : 11msec, Sine wave ±X, ±Y, ±Z Once for each direction
9	Electro-static discharge test	Air : ±15kV, 150pF/330Ω, 100Point, 1time/Point Contact : ±8kV, 150pF/330Ω, 100Point, 1time/Point Non operation Contact: ±4KV~±6KV, 150pF/330Ω, 100Point, Input connector Pin, 3 times/pin with no function loss



京东方
BOE

PRODUCT GROUP

REV

ISSUE DATE

TFT LCD

P0

2012.02.15

9.0 PRODCUT SERIAL NUMBER



- 1. Control Number
- 2. Rank / Grade
- 3. Line Classification
- 4. Year (2011 : 11, 2012 : 12, ...)

- 5. Month (1,2,3, ... , 9, X, Y, Z)
- 6. Internal Use
- 7. Serial Number

SPEC. NUMBER
S8XX-XXXX

SPEC. TITLE
HV460WU2-200 Preliminary Product Specification

PAGE
19 of 24

10.0 PACKING INFORMATION

BOE provides the standard shipping container for customers, unless customer specifies their packing information. The standard packing method and Barcode information are shown in below.

10.1 Packing Order

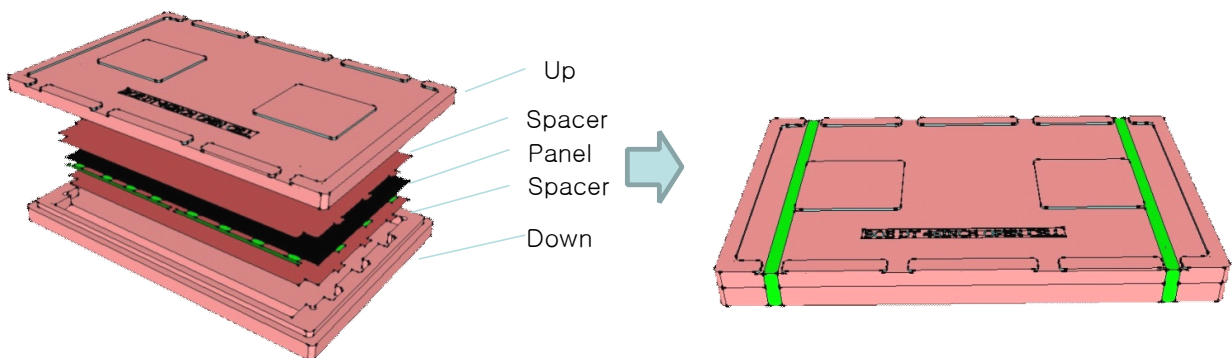

Stowage: Spacer + Panel + Spacer+...+Panel + Spacer

Total: Spacer: 11pcs, Panel: 10pcs

Dense box packing method



6 Inner Box/120Pcs/1 Pallet

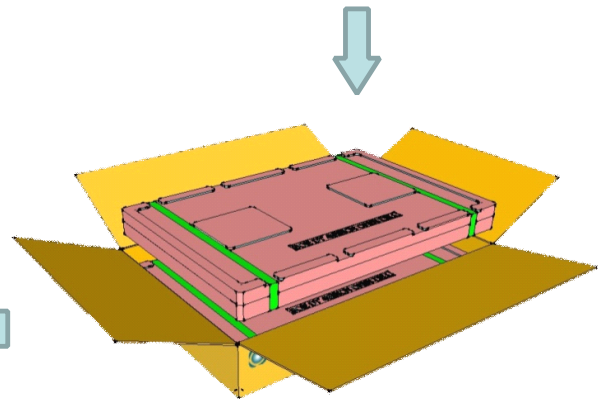

2 Dense Box/1 Inner Box

Packing method

SPEC. NUMBER
S8XX-XXXX

SPEC. TITLE
HV460WU2-200 Preliminary Product Specification

PAGE
20 of 24



京东方
BOE

PRODUCT GROUP

REV

ISSUE DATE

TFT LCD

P0

2012.02.15

10.2 Packing Note

- Box Dimension : 875mmL × 597mmW × 279mmH
- Package Quantity in one Box : 10pcs

10.3 Box Label

- Label Size : 110 mm (L) × 55 mm (W)
- Contents
 - Model : HV460WU2-200
 - Q'ty : 10 Open Cell in one box.
 - Serial No. : Box Serial No. See next page for detail description.
 - Date : Packing Date
 - FG Code : FG Code of Product

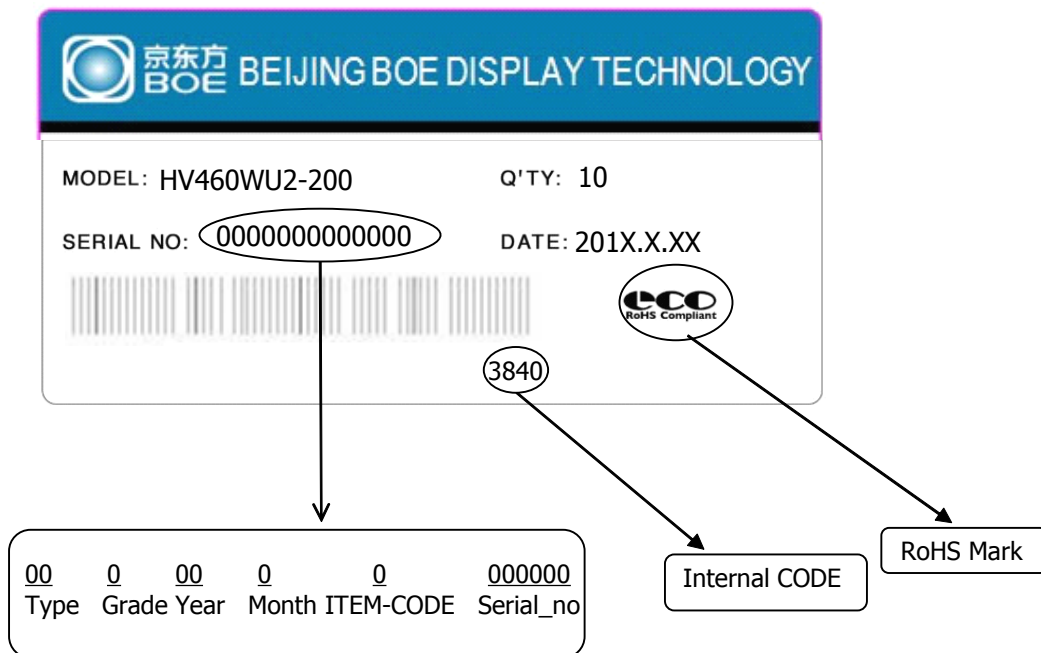

SPEC. NUMBER
S8XX-XXXX

SPEC. TITLE
HV460WU2-200 Preliminary Product Specification

PAGE
21 of 24



11.0 HANDLING & CAUTIONS

- (1) Cautions when taking out the module
 - Pick the pouch only, when taking out module from a shipping package.
- (2) Cautions for handling the module
 - As the electrostatic discharges may break the LCD module, handle the LCD module with care. Peel a protection sheet off from the LCD panel surface as slowly as possible.
 - As the LCD panel and back - light element are made from fragile glass material, impulse and pressure to the LCD module should be avoided.
 - As the surface of the polarizer is very soft and easily scratched, use a soft dry cloth without chemicals for cleaning.
 - Do not pull the interface connector in or out while the LCD module is operating.
 - Put the module display side down on a flat horizontal plane.
 - Handle connectors and cables with care.
- (3) Cautions for the operation
 - When the module is operating, do not lose CLK, ENAB signals. If any one of these signals is lost, the LCD panel would be damaged.
 - Obey the supply voltage sequence. If wrong sequence is applied, the module would be damaged.
- (4) Cautions for the atmosphere
 - Dew drop atmosphere should be avoided.
 - Do not store and/or operate the LCD module in a high temperature and/or humidity atmosphere. Storage in an electro-conductive polymer packing pouch and under relatively low temperature atmosphere is recommended.
- (5) Cautions for the module characteristics
 - Do not apply fixed pattern data signal to the LCD module at product aging.
 - Applying fixed pattern for a long time may cause image sticking.
- (6) Other cautions
 - Do not disassemble and/or re-assemble LCD module.
 - Do not re-adjust variable resistor or switch etc.
 - When returning the module for repair or etc., Please pack the module not to be broken. We recommend to use the original shipping packages.



12.0 APPENDIX

< Figure 1. Measurement Set Up >

PR730

(L = 180cm)

< Figure 2. Response Time Testing >

Any level of gray (Bright)

Any level of gray (Dark)

Any level of gray (Bright)

