

32-Channel LCD Driver with Separate Backplane Output

Ordering Information

Device	Package Options		
	44-J Lead Quad Plastic Chip Carrier	44 Lead Quad Plastic Gullwing	Dice in waffle pack
HV65	HV6506PJ	HV6506PG	HV6506X

Features

- Processed with HVC MOS[®] technology
- 32 push-pull CMOS output up to 60V
- Low power level shifting
- Source/sink current minimum 5mA
- Shift register speed 5MHz
- Latched data outputs
- Bidirectional shift register (DIR)
- Backplane output

General Description

The HV65 is a low-voltage serial to high-voltage parallel converter with push-pull outputs. This device has been designed for use as a driver circuit for LCD displays. It can also be used in any application requiring multiple output high-voltage current sourcing and sinking capabilities. The inputs are fully CMOS compatible.

The device consists of a 32-bit shift register, 32 latches, and control logic to perform the polarity select of the outputs. HVOut1 is connected to the first stage of the shift register through the polarity logic. Data is shifted through the shift register on the logic low to high transition of the clock. A DIR pin causes data shifting counterclockwise when grounded and clockwise when connected to V_{DD} . A data output buffer is provided for cascading devices. This output reflects the current status of the last bit of the shift register. Operation of the shift register is not affected by the LE (latch enable) or the POL (polarity) inputs. Transfer of data from the shift register to the latch occurs when the LE (latch enable) input is high. The data in the latch is stored after LE transition from high to low.

Absolute Maximum Ratings¹

Supply voltage, V_{DD} ²	-0.5V to +7.0V
Output voltage, V_{PP} ²	-0.5V to +80V
Logic input levels ²	-0.5V to $V_{DD} + 0.5V$
Ground current ³	1.5A
Continuous total power dissipation ⁴	1500mW
Operating temperature range	-40°C to +85°C
Storage temperature range	-65°C to +125°C
Lead temperature 1.6mm (1/16 inch) from case for 10 seconds	260°C

Notes:

1. Device will survive (but operation may not be specified or guaranteed) at these extremes.
2. All voltages are referenced to V_{SS} .
3. Duty cycle is limited by the total power dissipated in the package.
4. For operation above 25°C ambient, derate linearly to 70°C at 12mW/°C.

Electrical Characteristics (over recommended operating conditions unless noted)

DC Characteristics ($V_{DD} = 5V$, $V_{PP} = 60V$, $V_{SS} = GND$)

Symbol	Parameter	Min	Max	Units	Conditions	
I_{DD}	V_{DD} supply current		15	mA	$V_{DD} = V_{DD} \text{ max}$ $f_{CLK} = 5\text{MHz}$	
I_{PP}	High voltage supply current		0.5	mA	Outputs high	
			0.5	mA	Outputs low	
I_{DDQ}	Quiescent V_{DD} supply current		0.5	mA	All $V_{IN} = V_{SS}$ or V_{DD}	
V_{OH}	High-level output	Q	50	V	$I_O = 5\text{mA}$, $V_{PP} = 60V$	
		Data out	4.6	V	$I_O = -100\mu\text{A}$	
V_{OL}	Low-level output	Q		8	V	$I_O = 5\text{mA}$, $V_{PP} = 60V$
		Data out		0.4	V	$I_O = 100\mu\text{A}$
I_{IH}	High-level logic input current		1	μA	$V_{IH} = V_{DD}$	
I_{IL}	Low-level logic input current		-1	μA	$V_{IL} = 0V$	
V_{OLBP}	Low-level output voltage, backplane		8	V	$I_O = 40\text{mA}$	
V_{OHBP}	High-level output voltage, backplane	48		V	$I_O = -40\text{mA}$	

AC Characteristics ($V_{DD} = 5V$, $V_{PP} = 60V$, $T_C = 25^\circ\text{C}$)

Symbol	Parameter	Min	Max	Units	Conditions
f_{CLK}	Clock frequency		5	MHz	
t_W	Clock width high or low	100		ns	
t_{SU}	Data set-up time before clock rises	25		ns	
t_H	Data hold time after clock rises	50		ns	
t_{ON}, t_{OFF}	Time from latch enable or POL to HV_{OUT}		500	ns	$C_L = 30\text{pF}$
t_{ON}, t_{OFF}	Time from POL to BP output		500	ns	$C_L = 30\text{pF}$
t_{DHL}	Delay time clock to data high to low		200	ns	$C_L = 15\text{pF}$
t_{DLH}	Delay time clock to data low to high		200	ns	$C_L = 15\text{pF}$
t_{DLE}	Delay time clock to LE low to high	50		ns	
t_{WLE}	Width of LE pulse	100		ns	
t_{SLE}	LE set-up time before clock rises	50		ns	

Recommended Operating Conditions

Symbol	Parameter	Min	Max	Units
V_{DD}	Logic supply voltage	4.5	5.5	V
V_{PP}	Output off voltage	0	60	V
V_{IH}	High-level input voltage	3.5	V_{DD}	V
V_{IL}	Low-level input voltage	0	0.8	V
f_{CLK}	Clock frequency		5	MHz
T_A	Operating free-air temperature	-40	+85	$^\circ\text{C}$
I_{OD}	Allowable current through output diodes		200	mA

Note:

Power-up sequence should be the following:

1. Connect ground.
2. Apply V_{DD} .
3. Set all inputs (Data, CLK, Enable, etc.) to a known state.
4. Apply V_{PP} .

Power-down sequence should be the reverse of the above.

5. The V_{PP} should not drop below 0V during operation.

Switching Waveforms

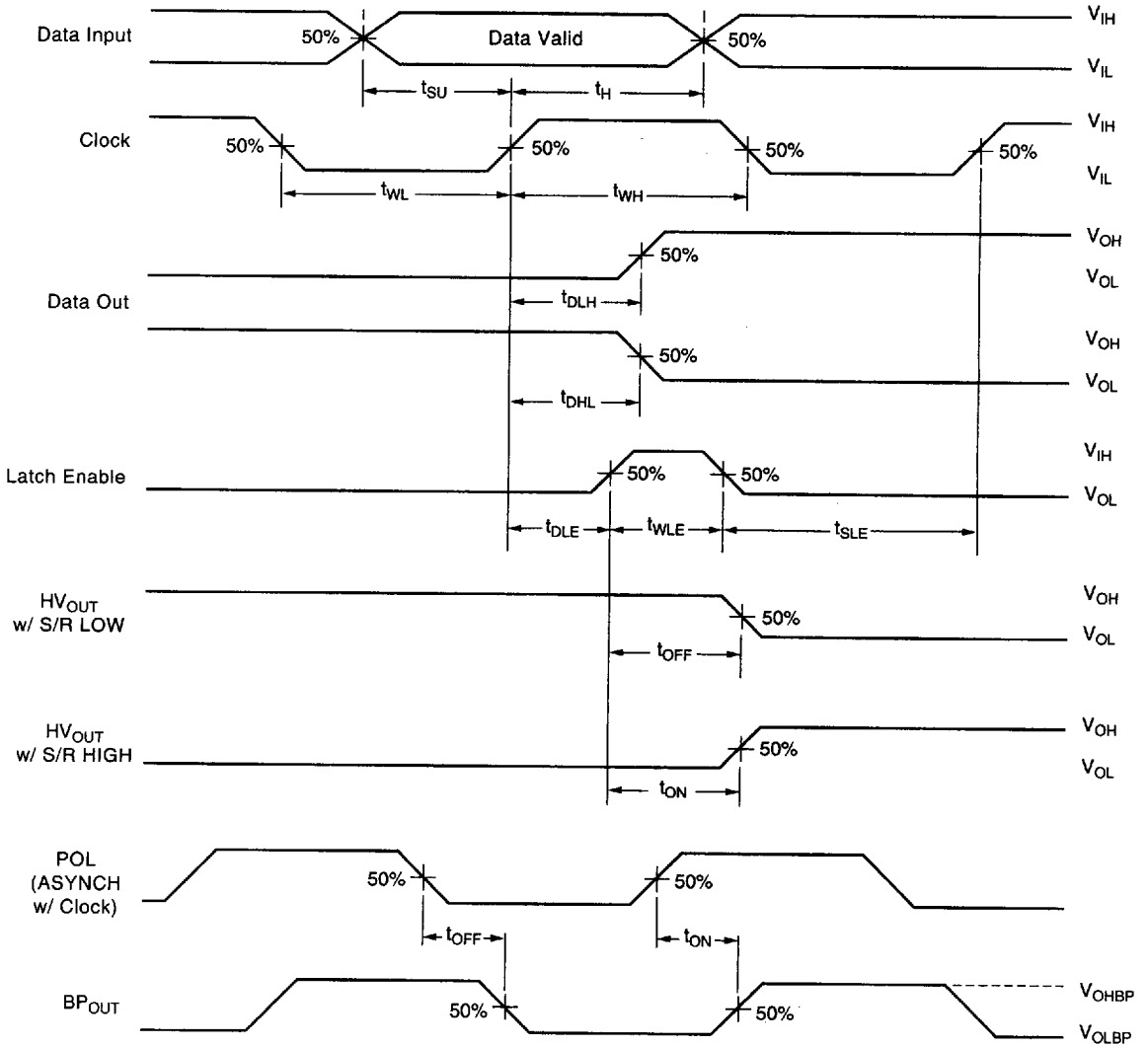

Functional Block Diagram

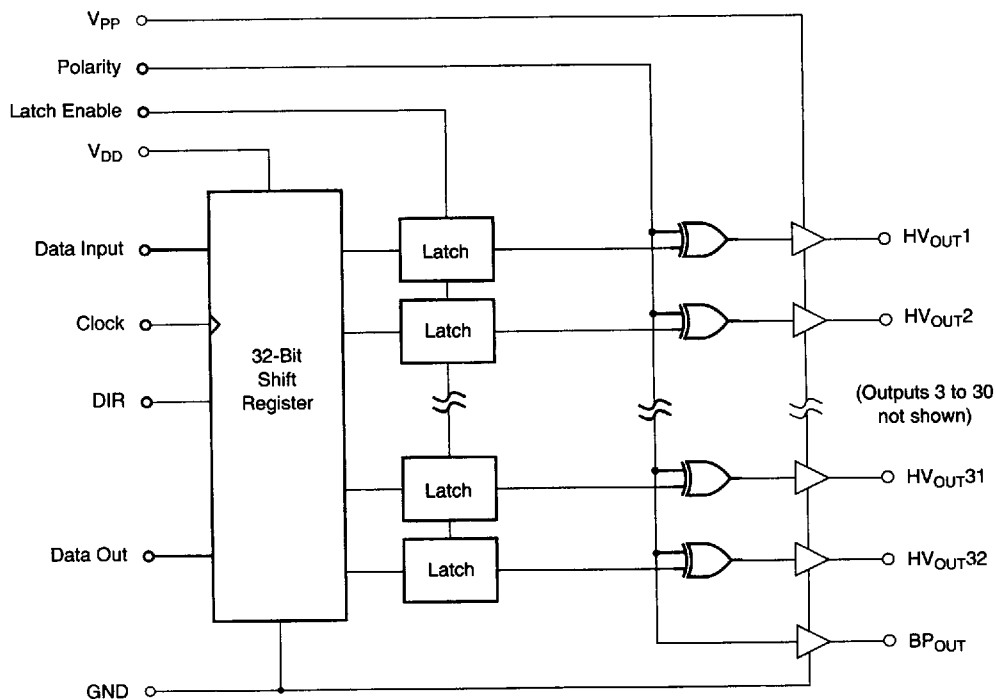

Function Table

Function	Inputs					Outputs				
	Data	CLK	LE	POL	DIR	Shift Reg 1 2...32	HV Outputs 1 2...32	Data Out 2...32	BP _{OUT} *	
Load S/R	H or L	↑	L	H	X	H or L *...*	* *...*	* *...*	H	
Load latches	X	H or L	L	H	X	* *...*	* *...*	* *...*	H	
	X	H or L	L	L	X	* *...*	* *...*	* *...*	L	
All high	H	↑	H	L	X	H *...*	H *...*	* *...*	L	
	L	↑	H	H	X	L *...*	H *...*	* *...*	H	
All low	H	↑	H	H	X	H *...*	L *...*	* *...*	H	
	L	↑	H	L	X	L *...*	L *...*	* *...*	L	
Transparent Mode	L	↑	H	H	X	L *...*	H *...*	* *...*	H	
	H	↑	H	H	X	H *...*	L *...*	* *...*	H	
	L	↑	H	L	X	L *...*	L *...*	* *...*	L	
	H	↑	H	L	X	H *...*	H *...*	* *...*	L	
R/L Shift	X	↑	X	X	H	Q _n → Q _{n+1}	* *...*	Q ₃₂		
	X	↑	X	X	L	Q _n → Q _{n-1}	* *...*	Q ₁		

Notes:

H = high level, L = low level, X = irrelevant, ↑ = low-to-high transition.

* = dependent on previous stage's state before the last CLK or last LE high.

Pin Configuration

HV65

44 Pin J-Lead Package

Pin	Function	Pin	Function
1	HV _{OUT} 17/16	23	LE
2	HV _{OUT} 16/17	24	V _{DD}
3	HV _{OUT} 15/18	25	Clock
4	HV _{OUT} 14/19	26	DIR
5	HV _{OUT} 13/20	27	Data In
6	HV _{OUT} 12/21	28	V _{PP}
7	HV _{OUT} 11/22	29	BP Out
8	HV _{OUT} 10/23	30	HV _{OUT} 32/1
9	HV _{OUT} 9/24	31	HV _{OUT} 31/2
10	HV _{OUT} 8/25	32	HV _{OUT} 30/3
11	HV _{OUT} 7/26	33	HV _{OUT} 29/4
12	HV _{OUT} 6/27	34	HV _{OUT} 28/5
13	HV _{OUT} 5/28	35	HV _{OUT} 27/6
14	HV _{OUT} 4/29	36	HV _{OUT} 26/7
15	HV _{OUT} 3/30	37	HV _{OUT} 25/8
16	HV _{OUT} 2/31	38	HV _{OUT} 24/9
17	HV _{OUT} 1/32	39	HV _{OUT} 23/10
18	Data Out	40	HV _{OUT} 22/11
19	GND	41	HV _{OUT} 21/12
20	N/C	42	HV _{OUT} 20/13
21	N/C	43	HV _{OUT} 19/14
22	POL	44	HV _{OUT} 18/15

HV65

44 Pin Plastic Gullwing (QFP) Package

Pin	Function	Pin	Function
1	HV _{OUT} 22/11	23	Data Out
2	HV _{OUT} 21/12	24	GND
3	HV _{OUT} 20/13	25	N/C
4	HV _{OUT} 19/14	26	N/C
5	HV _{OUT} 18/15	27	POL
6	HV _{OUT} 17/16	28	LE
7	HV _{OUT} 16/17	29	V _{DD}
8	HV _{OUT} 15/18	30	Clock
9	HV _{OUT} 14/19	31	DIR
10	HV _{OUT} 13/20	32	Data In
11	HV _{OUT} 12/21	33	V _{PP}
12	HV _{OUT} 11/22	34	BP Out
13	HV _{OUT} 10/23	35	HV _{OUT} 32/1
14	HV _{OUT} 9/24	36	HV _{OUT} 31/2
15	HV _{OUT} 8/25	37	HV _{OUT} 30/3
16	HV _{OUT} 7/26	38	HV _{OUT} 29/4
17	HV _{OUT} 6/27	39	HV _{OUT} 28/5
18	HV _{OUT} 5/28	40	HV _{OUT} 27/6
19	HV _{OUT} 4/29	41	HV _{OUT} 26/7
20	HV _{OUT} 3/30	42	HV _{OUT} 25/8
21	HV _{OUT} 2/31	43	HV _{OUT} 24/9
22	HV _{OUT} 1/32	44	HV _{OUT} 23/10

Note:

- Pin designation for DIR = H/L
 Example: for DIR = H, Pin 1 = HV_{OUT} 17
 for DIR = L, Pin 1 = HV_{OUT} 16

Note:

- Pin designation for DIR = H/L
 Example: for DIR = H, Pin 1 is HV_{OUT} 22
 for DIR = L, Pin 1 is HV_{OUT} 11

Package Outline

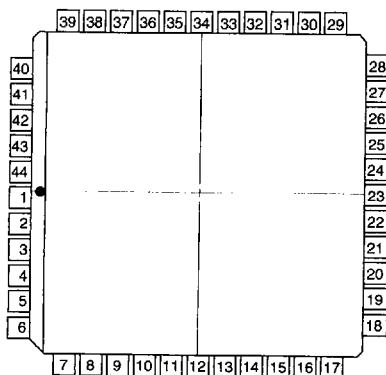

top view

44-pin J-Lead Package

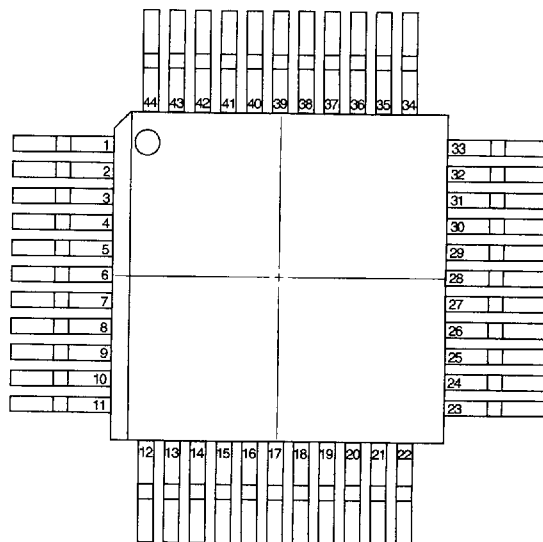

top view

44-pin Quad Plastic Gullwing Package