

Hysteretic Boost-Buck (Ćuk) LED Driver ICs

Features

- ❑ Constant Output Current
- ❑ Steps Output Voltage Up or Down
- ❑ Low EMI
- ❑ Variable Frequency Operation
- ❑ Internal 8 to 200V Linear Regulator
- ❑ Input and output current sensing
- ❑ Input Current limit
- ❑ Enable & PWM Dimming

Applications

- ❑ Automotive LED Drivers
- ❑ RGB backlight applications
- ❑ Battery Powered LED Lamps
- ❑ Other Low Voltage AC/DC or DC/DC LED Drivers

General Description

The HV9930 is a variable frequency PWM controller IC designed to control an LED lamp driver using a low noise boost-buck (Ćuk) topology. The HV9930 uses hysteretic-current mode control to regulate both the input and the output currents. This enables fast transient response (required for PWM dimming) without the necessity for complex loop compensation. Input current control enables current limiting during startup and output overload conditions. Capacitive isolation protects the LED Lamp from failure of the switching MOSFET. HV9930 provides a low-frequency PWM dimming input that can accept an external control signal with a duty ratio of 0-100%.

The HV9930 based LED driver is ideal for automotive LED lamps and RGB backlight applications with low voltage DC inputs. The HV9930 based LED Lamp drivers can achieve efficiency in excess of 80%.

Typical Application Circuit

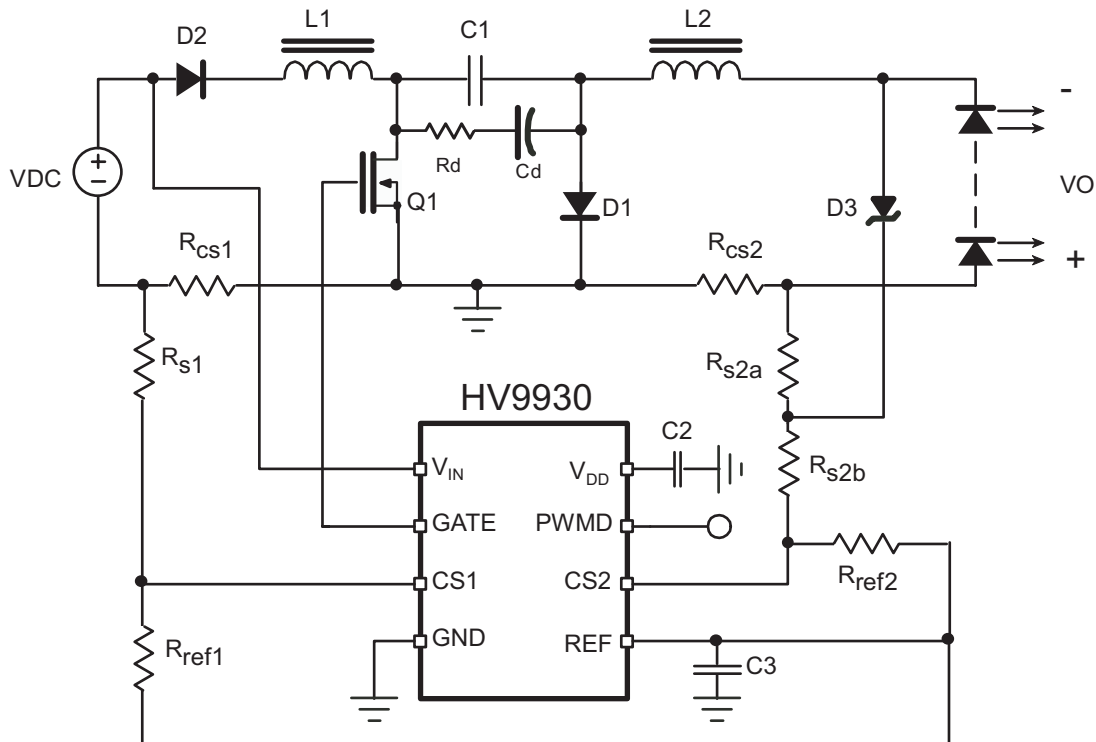

Ordering Information

Package Options		
Device	8 pin SOIC	8 pin DIP
HV9930	HV9930LG-G	HV9930P-G

-G indicates package is RoHS compliant 'Green'



Absolute Maximum Ratings

V_{IN} to GND	-0.5V to +200V
V_{DD} to GND	-0.3V to +13.5V
CS1, CS2 to GND	-0.3V to $V_{DD} + 0.3V$
PWMD to GND	-0.3V to $(V_{DD} + 0.3V)$
GATE to GND	0.3V to $(V_{DD} + 0.3V)$
Continuous Power Dissipation ($T_A = +25^\circ C$) (Note 1)	
8-Pin DIP (derate 9mW/ $^\circ C$ above +25 $^\circ C$)	900mW
8-Pin SO (derate 6.3mW/ $^\circ C$ above 25 $^\circ C$)	630mW
Operating Temperature Range	-40 $^\circ C$ to +85 $^\circ C$
Junction Temperature	+125 $^\circ C$
Storage Temperature Range	-65 $^\circ C$ to +150 $^\circ C$

Stresses beyond those listed under "Absolute Maximum Ratings" may cause permanent damage to the device. These are stress ratings only, and functional operation of the device at these or any other conditions beyond those indicated in the operational sections of the specifications is not implied. Exposure to absolute maximum rating conditions for extended periods may affect device reliability.

www.DataSheet4U.com

Electrical Characteristics

(The * denotes the specifications which apply over the full operating junction temperature range of $0^\circ C < T_A < +85^\circ C$, otherwise the specifications are at $T_A = 25^\circ C$, $V_{DD} = 7.5V$, unless otherwise noted)

Symbol	Description	Min	Typ	Max	Units	Conditions
Input						
V_{INDC}	Input DC supply voltage range*	8		200	V	DC input voltage
I_{INsd}	Shut-Down mode supply current*		0.5	1	mA	PWMD_D connected to GND, $V_{IN} = 12V$
Internal Regulator						
V_{DD}	Internally regulated voltage	7.0	7.5	9.0	V	$V_{IN} = 8-200V$, $I_{DD(ext)} = 0$, GATE open
$I_{DD(ext)}$	V_{DD} current available for external circuitry ¹			1.0	mA	$V_{IN} = 8-200V$
UVLO	V_{DD} under voltage lockout threshold	6.45	6.7	6.95	V	V_{IN} rising
$\Delta UVLO$	V_{DD} under voltage lockout hysteresis		500		mV	
$V_{DD(ext)}$	Steady State external voltage which can applied at the V_{DD} pin			12	V	
Reference						
V_{REF}	REF pin voltage*	1.212	1.25	1.288	V	REF bypassed with a 0.1 μF capacitor to GND; $I_{REF} = 0$; $V_{DD} = 7.5V$; PWMD = 5V
$V_{REFLINE}$	Line regulation of reference voltage	0		20	mV	REF bypassed with a 0.1 μF capacitor to GND; $I_{REF} = 0$; $V_{DD} = 7 - 12V$; PWMD = 5V
I_{REF}	Reference Output current range ¹	-0.01		1.0	mA	REF bypassed with a 0.1 μF capacitor to GND; $V_{DD} = 7 - 12V$; PWMD = 5V
$V_{REFLOAD}$	Load regulation of reference voltage	0		25	mV	REF bypassed with a 0.1 μF capacitor to GND; $I_{REF} = 0 - 500\mu A$; $V_{DD} = 7.5$; PWMD = 5V
PWM Dimming						
$V_{PWMD(lo)}$	PWMD input low voltage*			0.8	V	$V_{IN} = 10 - 200V$
$V_{PWMD(hi)}$	PWMD input high voltage*	2.4			V	$V_{IN} = 10 - 200V$
R_{PWMD}	PWMD pull-down resistance	50	100	150	k Ω	$V_{PWMD} = 5V$

Gate						
I_{SOURCE}	GATE short circuit current, sourcing	0.165			A	$V_{GATE} = 0V$; $V_{DD} = 7.5V$
I_{SINK}	GATE sinking current	0.165			A	$V_{GATE} = 10V$; $V_{DD} = 7.5V$
T_{RISE}	GATE output rise time		30	50	ns	$C_{GATE} = 500pF$; $V_{DD} = 7.5V$
T_{FALL}	GATE output fall time		30	50	ns	$C_{GATE} = 500pF$; $V_{DD} = 7.5V$
Input Current Sense Comparator						
$V_{TURNON1}$	Voltage required to turn GATE on [*]	88	100	112	mV	CS2 = 200mV ; CS1 increasing ; GATE goes LOW to HIGH
$V_{TURNOFF1}$	Voltage required to turn GATE off [*]	-12	0	12	mV	CS2 = 200mV ; CS1 decreasing ; GATE goes HIGH to LOW
$T_{D1, ON}$	Delay to Output (turn-on)		150	250	ns	CS2=200mV ; CS1 = 50mV to 200mV step
$T_{D1, OFF}$	Delay to Output (turn-on)		150	250	ns	CS2=200mV ; CS1 = 50mV to -100mV step
Output Current Sense Comparator						
$V_{TURNON2}$	Voltage required to turn GATE on [*]	88	100	112	mV	CS1 = 200mV ; CS2 increasing ; GATE goes LOW to HIGH
$V_{TURNOFF2}$	Voltage required to turn GATE off [*]	-12	0	12	mV	CS1 = 200mV ; CS2 decreasing ; GATE goes HIGH to LOW
$T_{D2, ON}$	Delay to Output (turn-on)		150	250	ns	CS1=200mV ; CS2 = 50mV to 200mV step
$T_{D2, OFF}$	Delay to Output (turn-on)		150	250	ns	CS1=200mV ; CS2 = 50mV to -100mV step

^{*} Also limited by package power dissipation limit, whichever is lower.

Pinout

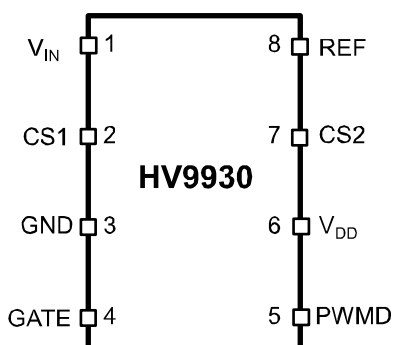

Pin Description

V_{IN} – This pin is the input of a 8-200V voltage regulator.

V_{DD} – This is a power supply pin for all internal circuits. It must be bypassed with a low ESR capacitor to GND.

GATE – This pin is the output gate driver for an external N-channel power MOSFET.

GND – Ground return for all the internal circuitry. This pin must be electrically connected to the ground of the power train.

REF – This pin provides accurate reference voltage. It must be bypassed with a 0.01-0.1uF capacitor to GND.

PWM – When this pin is pulled to GND, switching of the HV9930 is disabled. When the PWM pin is released, or external TTL high level is applied to it, switching will resume. This feature is provided for applications that require PWM dimming of the LED lamp.

CS1 and CS2 – These pins are used to sense the input and output currents of the boost-buck converter. They are the non-inverting inputs of the internal comparators.

Functional Block Diagram

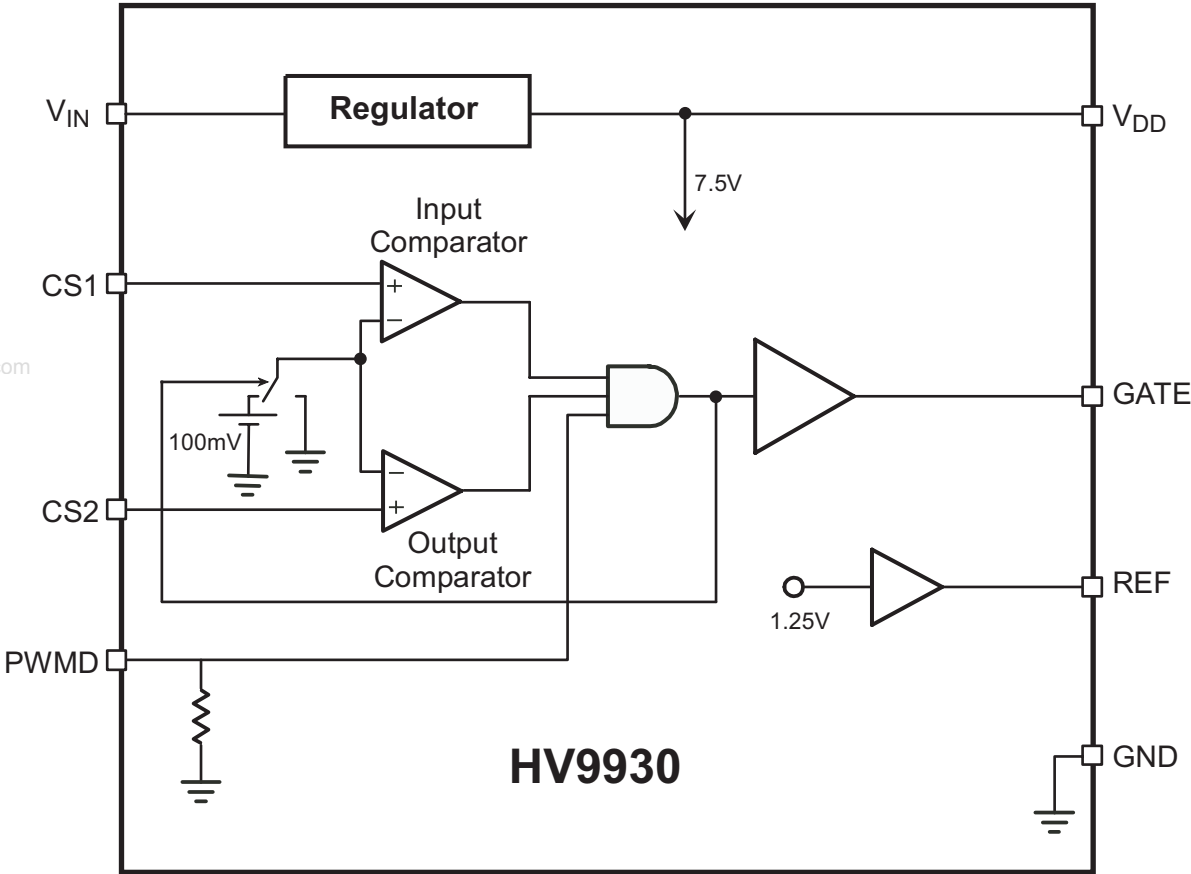

www.DataSheet4U.com

Functional Description

Power Topology

The HV9930 is optimized to drive a continuous conduction mode (CCM) boost-buck DC/DC converter topology commonly referred to as “Ćuk converter” (see Circuit Diagram on page 1). This power converter topology offers numerous advantages useful for driving high-brightness light emitting diodes (HB LED). These advantages include step-up or step-down voltage conversion ratio and low input and output current ripple. The input and the output inductors can also share a common core. The output load is decoupled from the input voltage with a capacitor making the driver inherently failure-safe for the output load.

The HV9930 offers a simple and effective control technique for use with a boost-buck LED driver. It uses two hysteretic mode controllers – one for the input and one for the output. The outputs of these two hysteretic comparators are AND together, and used to drive the external FET. This control scheme gives accurate current control and constant output current in the presence of input voltage transients without the need for complicated loop design.

Input Voltage Regulator

The HV9930 can be powered directly from its V_{IN} pin that takes a voltage from 8V to 200V. When a voltage is applied at the V_{IN} pin, the HV9930 tries to maintain a constant 7.5V (typ) at the V_{DD} pin. The regulator also has a built in under-voltage lockout which shuts off the IC if the voltage at the V_{DD} pin falls below the UVLO threshold.

The V_{DD} pin must be bypassed by a low ESR capacitor ($\geq 0.1\mu\text{F}$) to provide a low impedance path for the high frequency current of the output gate driver.

The IC can also be operated by supplying a voltage at the V_{DD} pin greater than the internally regulated voltage. This will turn off the internal linear regulator and the IC will function by drawing power from the external voltage source connected to the V_{DD} pin.

In case of input transients that reduce the input voltage below 8V (like cold crank condition in an automotive system), the V_{IN} pin of the HV9930 can be connected to the drain of the MOSFET through a diode. Since the drain of the FET is at a voltage equal to the sum of the input and output voltages, the IC will still be operational when the input goes below 8V. In these cases, a larger capacitor is needed to the V_{DD} pin to supply power to the IC when the MOSFET is ON.

Reference

An internally trimmed voltage reference of 1.25V (+/- 3%) is provided at the REF pin. The reference can supply a maximum output current of 1mA to drive external circuitry.

This reference can be used to set the current thresholds of the two comparators as shown in the Typical Application Circuit.

Current Comparators

The HV9930 features two identical comparators with a built-in 100mV hysteresis. When the GATE is low, the inverting terminal is connected to 100mV and when the GATE is high, it is connected to GND. One comparator is used for the input current control and the other for the output current control.

The input side hysteretic controller is in operation only during start-up and overload conditions. This ensures that the input current never exceeds the designed value. During normal operation, the input current will be less than the programmed current and hence, the output of the input side comparator will be HIGH. The output of the AND gate will then be dictated by the output current controller.

The output side hysteretic comparator will be in operation during the steady state operation of the circuit. This comparator turns the MOSFET on and off based on the LED current.

The use of these comparators in a boost-buck topology is a patent-pending technique, which eliminates the need for compensation components.

PWM Dimming

PWM Dimming can be achieved by applying a TTL-compatible square wave signal at the PWM pin. When the PWMD pin is pulled high, the gate driver is enabled and the circuit operates normally. When the PWMD pin is left open or connected to GND, the gate driver is disabled and the external MOSFET turns off. The IC is designed so that the signal at the PWMD pin inhibits the driver only and the IC need not go through the entire start-up cycle each time ensuring a quick response time for the output current.

The flying capacitor in the Cuk converter (C1) is initially charged to the input Voltage VDC (through diodes D1 and D2). When the circuit is turned on and reaches steady state, the voltage across C1 will be $V_{DC}+V_O$. In the absence of diode D2, when the circuit is turned off, capacitor C1 will discharge through the LEDs and the input voltage source VDC. Thus, during PWM dimming, if capacitor C1 has to charged and discharged each cycle, the transient response of the circuit will be limited. By adding diode D2, the voltage across capacitor C1 is held at $V_{DC}+V_O$ even when the circuit is turned off enabling the circuit to return quickly to its steady state (and bypassing the start-up stage) upon being enabled.

Application Information

Over-voltage Protection

Over-voltage protection can be added by splitting the output side resistor R_{s2} into two components and adding a zener diode D3. When there is an open LED condition, the diode D3 will clamp the output voltage and the zener diode current will be regulated by the sum of R_{s2a} and R_{cs2} .

Damping Circuit

The Cuk converter is inherently unstable when the output current is being controlled. An uncontrolled input current will lead to an un-damped oscillation between L1 and C1 causing excessively high voltages across C1. To prevent these oscillations, a damping circuit consisting of R_d and C_d is applied across the capacitor C1. This damping circuit will help to stabilize the circuit and help in the proper operation of the HV9930 based Cuk converter.

Design and Operation of the Boost-Buck Converter

For details on the design for a Boost-Buck converter using the HV9930 and the calculation of the damping components, please refer to Application Note AN-H51.

Design Example

The choice of the resistor dividers to set the input and output current levels is illustrated by means of the design example given below.

The parameters of the power circuit are:

$$\begin{aligned} V_{in\ min} &= 9V \\ V_{in\ max} &= 16V \\ V_o &= 28V \\ I_o &= 0.35A \\ f_{s\ min} &= 300kHz \end{aligned}$$

Using these parameters, the values of the power stage inductors and capacitor can be computed as (see Application Note AN-H51 for details):

$$\begin{aligned} L1 &= 82\ \mu H \\ L2 &= 150\ \mu H \\ C1 &= 0.22\ \mu F \end{aligned}$$

The input and output currents for this design are:

$$\begin{aligned} I_{in\ max} &= 1.6A \\ \Delta I_{in} &= 0.21A \end{aligned}$$

$$\begin{aligned} I_o &= 350mA \\ \Delta I_o &= 87.5mA \end{aligned}$$

Output Current Limits

The current sense resistor (R_{cs2}), combined with the other resistors (R_{s2} & R_{ref2}), determines the output current limits.

The current sense resistor (R_{cs1}), combined with the other resistors (R_{s1} & R_{ref1}), determines the input current limits.

The resistors can be chosen using the following equations:

$$I \times R_{cs} = 1.2V \times \frac{R_s}{R_{Ref}} - 0.05V \quad (1)$$

$$\Delta I \times R_{cs} = 0.1V \times \frac{R_s}{R_{Ref}} + 0.1V \quad (2)$$

Where I is the current (either I_o or I_{in}) and ΔI is the peak-to-peak ripple in the current (either ΔI_o or ΔI_{in}).

For the input side, the current level used in the equations should be larger than the maximum input current so that it does not interfere with the normal operation of the circuit. The peak input current can be computed as:

$$\begin{aligned} I_{in,pk} &= I_{in,max} + \frac{\Delta I_{in}}{2} \\ &= 1.706A \end{aligned} \quad (3)$$

Assuming a 30% peak-to-peak ripple when the converter is in input current limit mode, the minimum value of the input current will be:

$$I_{lim,min} = 0.85 \cdot I_{in,lim} \quad (4)$$

Setting

$$I_{lim,min} = 1.05 \cdot I_{in,pk} \quad (5)$$

The current level to limit the converter can then be computed.

$$\begin{aligned} I_{in,lim} &= \frac{1.05}{0.85} \cdot I_{in,pk} \\ &= 2.1A \end{aligned} \quad (6)$$

Using $I_o = 0.35A$ and $\Delta I_o = 0.0875A$ in (1) and (2),

$$\begin{aligned} R_{cs2} &= 1.78\ \Omega \\ \frac{R_{s2}}{R_{ref2}} &= 0.5625 \end{aligned}$$

Before the design of the output side is complete, over voltage protection has to be included in the design. For this application, choose a 33V zener diode. This is the voltage at which the output will clamp in case of an open LED condition. For a 350mW diode, the maximum current rating at 33V works out to about 10mA. Using a 2.5mA current level during open LED conditions, and assuming the same R_{s2}/R_{ref2} ratio,

$$R_{cs2} + R_{s2a} = 120\ \Omega \quad (6)$$

Choose the following values for the resistors:

$$\begin{aligned} R_{cs2} &= 1.65\ \Omega, 1/4W, 1\% \\ R_{ref2} &= 10k\ \Omega, 1/8W, 1\% \\ R_{s2a} &= 100\ \Omega, 1/8W, 1\% \\ R_{s2b} &= 5.23k\ \Omega, 1/8W, 1\% \end{aligned}$$

The current sense resistor needs to be at least a 1/4W, 1% resistor.

Similarly, using $I_{in} = 2.1A$ and $\Delta I_{in} = 0.3 \times I_{in} = 0.63A$ in (1) and (2),

$$\begin{aligned} \frac{R_{s1}}{R_{ref1}} &= 0.442 \\ R_{cs1} &= 0.228\ \Omega \\ P_{Rcs1} &= I_{in,lim}^2 \cdot R_{cs1} = 1W \end{aligned}$$

Choose the following values for the resistors:

$$\begin{aligned} R_{cs1} &= \text{parallel combination of three} \\ &\quad 0.68\ \Omega, 1/2W, 5\% \text{ resistors} \\ R_{ref1} &= 10k\ \Omega, 1/8W, 1\% \\ R_{s1} &= 4.42k\ \Omega, 1/8W, 1\% \end{aligned}$$

8-LEAD SMALL OUTLINE PACKAGE (LG) (MS-012AA)

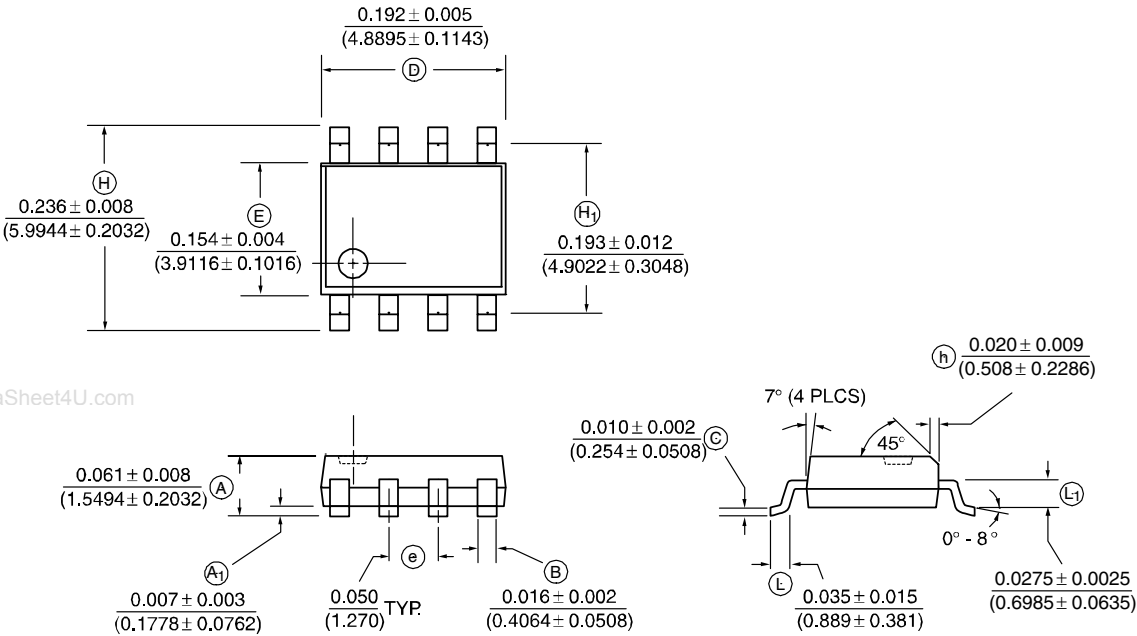

Note: Circle (e.g. B) indicates JEDEC Reference.

Measurement Legend = $\frac{\text{Dimensions in Inches}}{\text{(Dimensions in Millimeters)}}$

8-LEAD PLASTIC DUAL IN-LINE PACKAGE (P)

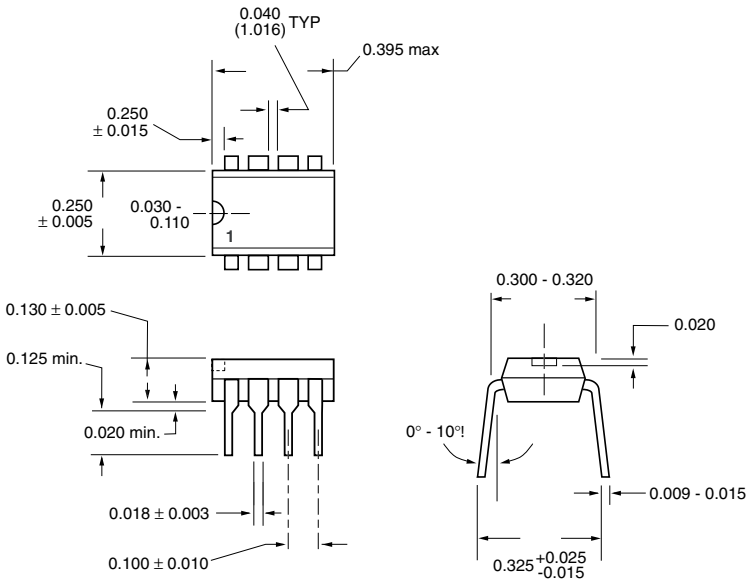

Note: Circle (e.g. B) indicates JEDEC Reference.

Measurement Legend = $\frac{\text{Dimensions in Inches}}{\text{(Dimensions in Millimeters)}}$

Supertex inc. does not recommend the use of its products in life support applications and will not knowingly sell its products for use in such applications unless it receives an adequate "products liability indemnification insurance agreement". **Supertex** does not assume responsibility for use of devices described and limits its liability to the replacement of the devices determined defective due to workmanship. No responsibility is assumed for possible omissions or inaccuracies. Circuitry and specifications are subject to change without notice. For the latest product specifications, refer to the **Supertex** website: <http://www.supertex.com>. For complete liability information on all **Supertex** products, refer to the most current databook or to the Legal/ Disclaimer page on the **Supertex** website.