

REVISION AZ

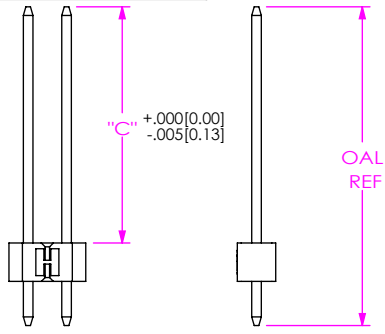

IN-PROCESS

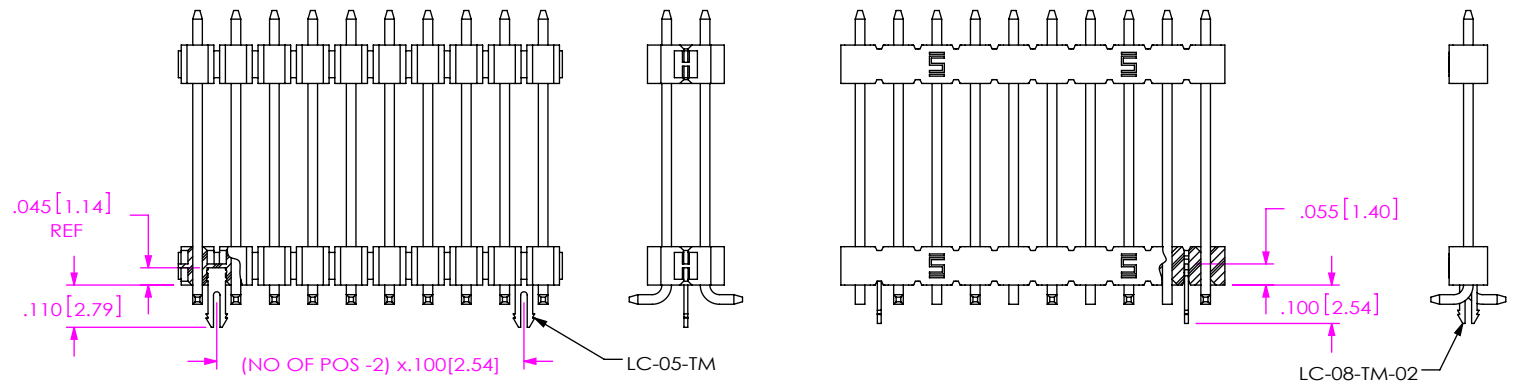

-D: DOUBLE ROW

FIG 2

-LC: LOCKING CLIP
(SAME AS FIG 1, DIFFERENT AS SHOWN)

-S: SINGLE ROW

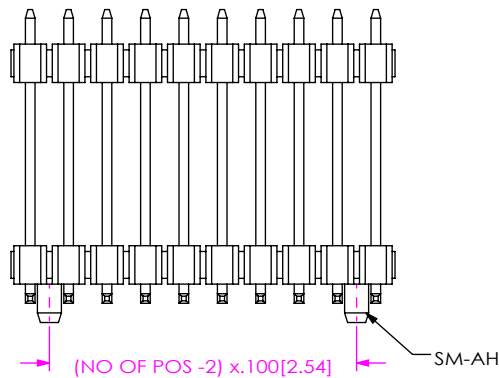

STACKED ALIGNMENT PINS

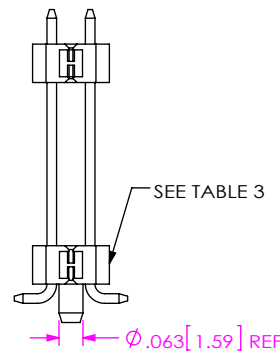

-D: DOUBLE ROW

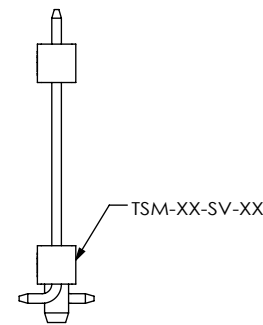

-S: SINGLE ROW

TABLE 3		
	"D"	BODY
MOLDED	.100[2.54] REF	RTSM-50-DVU-XX TSM-XX-SV-XX
STAKED	.100[2.54] ±.005[0.13]	RTSM-50-DVU

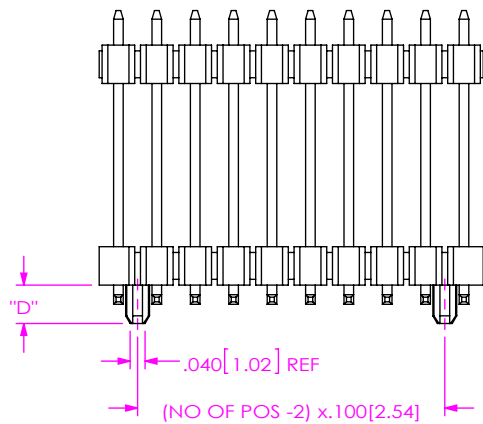

MOLDED ALIGNMENT PINS

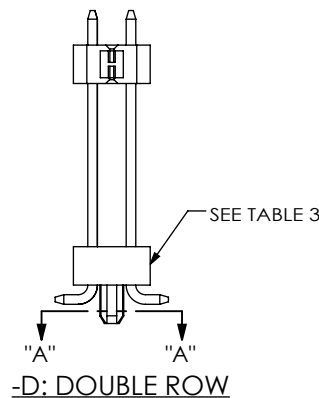

-D: DOUBLE ROW

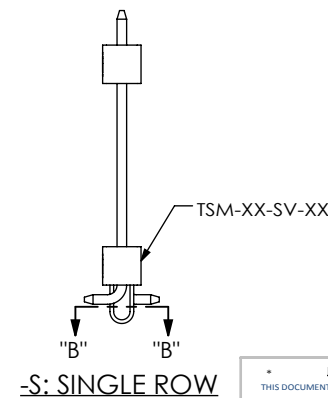

-S: SINGLE ROW

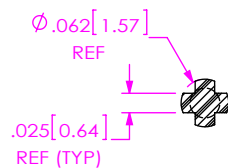

SECTION "A"-"A"
SCALE 4 : 1

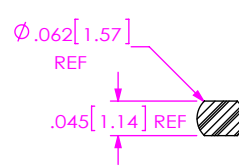

SECTION "B"-"B"
SCALE 4 : 1

FIG 3
-A: ALIGNMENT PIN
(SAME AS FIG 1, DIFFERENT AS SHOWN)
(2 POS USE 1 PER STRIP, 3-36 POS USE 2 PER STRIP)

PROPRIETARY NOTE
THIS DOCUMENT CONTAINS CONFIDENTIAL AND PROPRIETARY INFORMATION AND ALL DESIGN, MANUFACTURING, REPRODUCTION, USE, PATENT RIGHTS AND SALES RIGHTS ARE EXPRESSLY RESERVED BY SAMTEC, INC. THIS DOCUMENT SHALL NOT BE DISCLOSED, IN WHOLE OR PART, TO ANY UNAUTHORIZED PERSON OR ENTITY NOR REPRODUCED, TRANSFERRED OR INCORPORATED IN ANY OTHER PROJECT IN ANY MANNER WITHOUT THE EXPRESS WRITTEN CONSENT OF SAMTEC, INC.



520 PARK EAST BLVD, NEW ALBANY, IN 47150
PHONE: 812-944-6733 FAX: 812-948-5047
e-Mail info@SAMTEC.com code 55322

DO NOT SCALE DRAWING

SHEET SCALE: 2:1

DESCRIPTION:
HW BOARD TO BOARD ASSEMBLY

DWG. NO.
HW-XX-XX-XX-X-XXXX-SM-X-XXX

BY: G PURVIS 03/12/1993 SHEET 2 OF 3

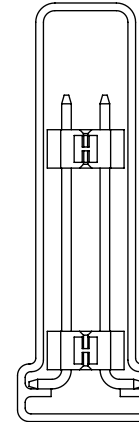
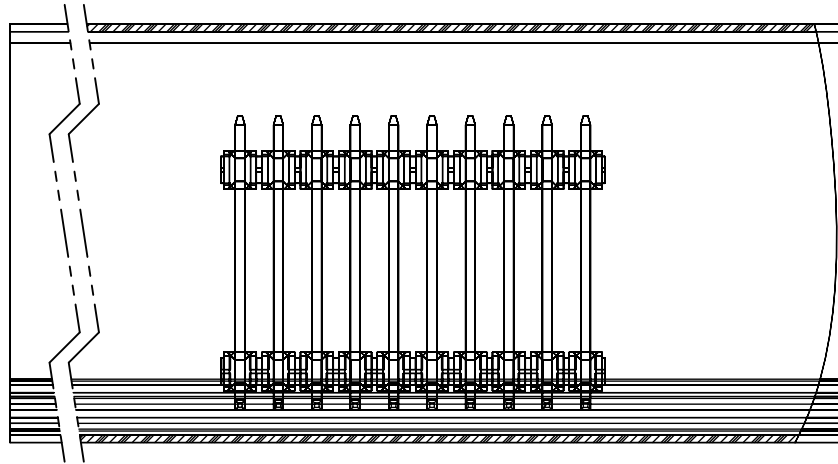

FIG 4
PACKAGING VIEW
(TUBE PLUG LOCATED AS SHOWN)

TABLE 2		
ROW OPTION	PACKAGING TUBE (SEE NOTE 2)	PLUG
-S: SINGLE	PT-1-24-01-47	TP-24
-D: DOUBLE	PT-1-24-02-47	TP-26
-LEAD STYLE -20 DOUBLE	PT-1-24-03-47	TP-26
-LEAD STYLE -20 SINGLE	PT-1-24-08-03	TP-07

PROPRIETARY NOTE
 THIS DOCUMENT CONTAINS CONFIDENTIAL AND PROPRIETARY INFORMATION AND ALL DESIGN, MANUFACTURING, REPRODUCTION, USE, PATENT RIGHTS AND SALES RIGHTS ARE EXPRESSLY RESERVED BY SAMTEC, INC. THIS DOCUMENT SHALL NOT BE DISCLOSED, IN WHOLE OR PART, TO ANY UNAUTHORIZED PERSON OR ENTITY NOR REPRODUCED, TRANSFERRED OR INCORPORATED IN ANY OTHER PROJECT IN ANY MANNER WITHOUT THE EXPRESS WRITTEN CONSENT OF SAMTEC, INC.



520 PARK EAST BLVD, NEW ALBANY, IN 47150
 PHONE: 812-944-6733 FAX: 812-948-5047
 e-Mail info@SAMTEC.com code 55322

DO NOT SCALE DRAWING

SHEET SCALE: 2:1

DESCRIPTION: HW BOARD TO BOARD ASSEMBLY

DWG. NO. HW-XX-XX-XX-X-XXXX-SM-X-XXX

BY: G PURVIS 03/12/1993 SHEET 3 OF 3