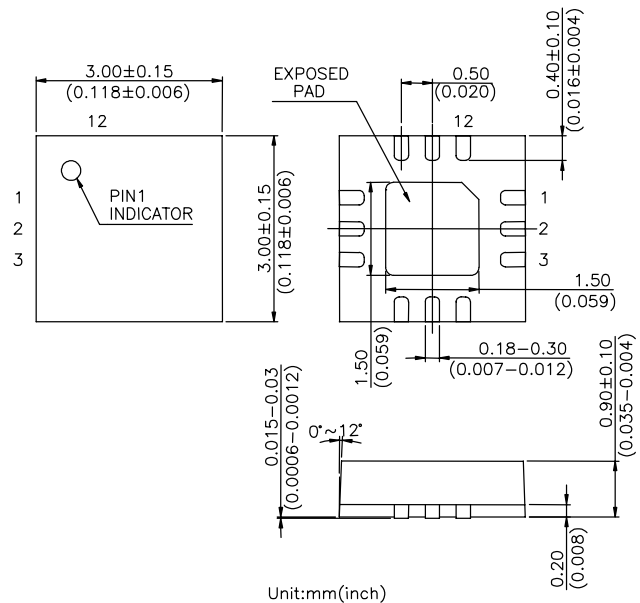

Features

- **Low Insertion Loss** : 0.8 dB @ 2.5 GHz
1.0 dB @ 4.9 to 6.0 GHz
- **High Isolation**: 37 dB @ 2.5 GHz
33 dB @ 4.9 to 6.0 GHz
- **Low DC Power Consumption**
- **Miniature QFN12L (3x3 mm) Plastic Lead (Pb) Free Package, RoHS Compliant**
- **PHEMT process**

QFN12L (3 x 3 mm)

Description

The HWS465 is a GaAs PHEMT MMIC DPDT switch operating at DC-6 GHz in a low cost miniature QFN12L (3 x 3 mm) plastic lead (Pb) free package. The HWS465 features low insertion loss and high isolation up to 6 GHz with very low DC power consumption. This switch can be used in IEEE 802.11a/b/g WLAN systems for combination of transmit/receive and antenna diversity functions.

Electrical Specifications at 25°C with 0, +3V Control Voltages

Parameter	Test Conditions	Min.	Typ.	Max.	Unit
Insertion Loss	0.1-6.0 GHz		1.0		dB
	2.4-2.5 GHz		0.8		dB
	4.9-6.0 GHz		1.0	1.3	dB
Isolation (on/off or off/on)	0.1-6.0 GHz		33		dB
	2.4-2.5 GHz		37		dB
	4.9-6.0 GHz	25	33		dB
Isolation (off/off)	2.4-2.5 GHz		10		dB
	4.9-6.0 GHz		17		dB
Isolation (TX to RX, ANT1 to ANT2)	2.4-2.5 GHz		24		dB
	4.9-6.0 GHz		20		dB
Return Loss	0.1-6.0 GHz		15		dB
Input Power for One dB Compression	2.0-6.0 GHz		30		dBm
Second Harmonic	Pin=20 dBm		-75		dBc
Third Harmonic	Pin=20 dBm		-75		dBc
Input Third Order Intermodulation Intercept Point	20 dBm Per Tone @ 5.85 GHz		45		dBm
Switching Time			50		ns
Control Current			5	100	uA

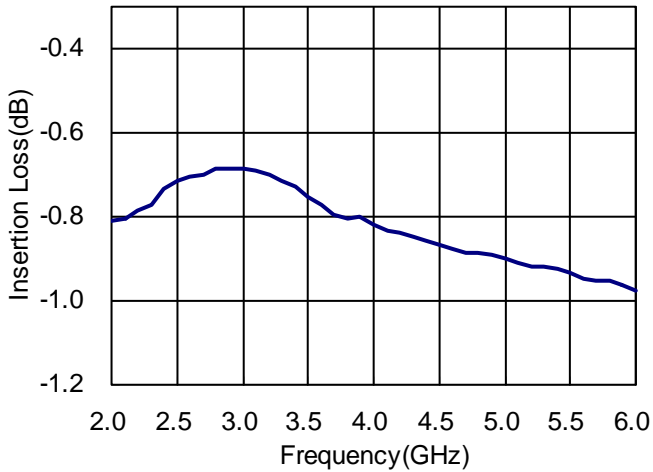
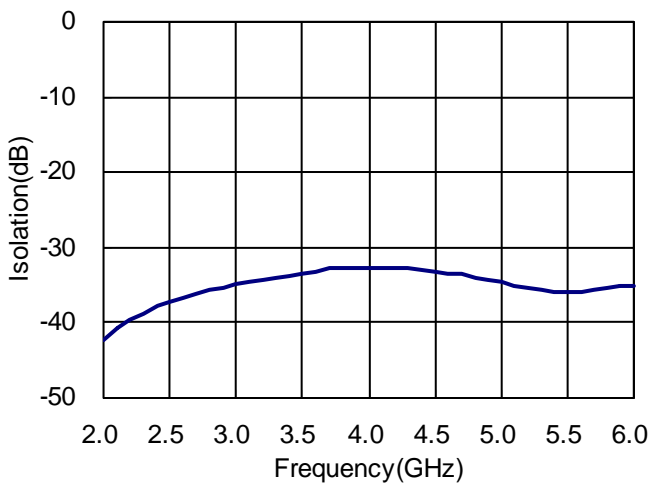
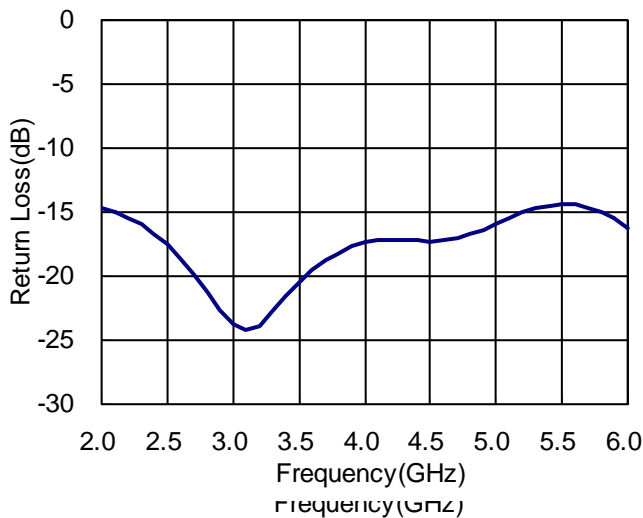
Note: All measurements made in a 50 ohm system with 0/+3.0V control voltages, unless otherwise specified.

Typical Performance Data with 8pF Capacitors @ +25°C
Insertion Loss vs Frequency

Isolation vs Frequency

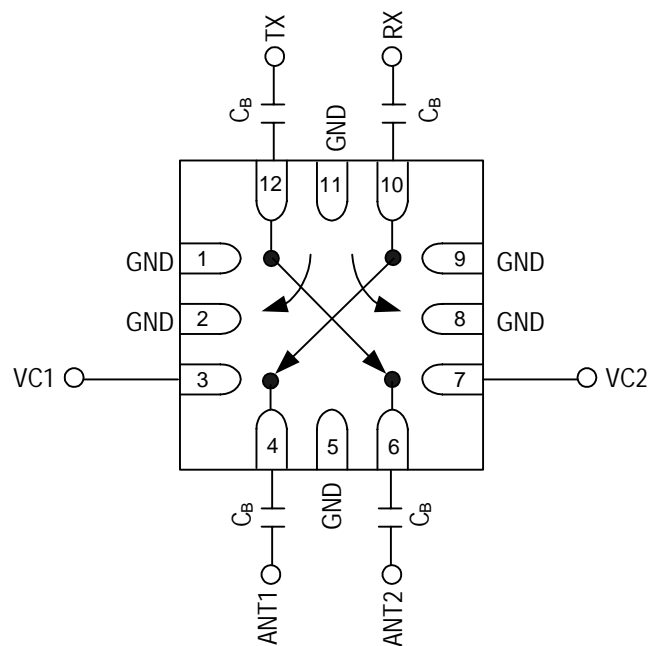
Return Loss vs Frequency

Absolute Maximum Ratings

Parameter	Absolute Maximum
RF Input Power	+32 dBm @ +3V
Control Voltage	+6V
Operating Temperature	-40°C to +90°C
Storage Temperature	-65°C to +150°C

Pin Out (Top View)

Note:

- DC blocking capacitors $C_B=8\text{pF}$ are required on all RF ports.
- Exposed pad in the bottom must be connected to ground by via holes.
- TX and RX ports can be used interchangeably.

Logic Table for Switch On-Path

VC1	VC2	ANT1-RX	ANT1-TX	ANT2-TX	ANT2-RX
1	0	On	Off	On	Off
0	1	Off	On	Off	On
1	1	Off	Off	Off	Off
0	0	Off	Off	Off	Off

'1' = +2.7V to +5V

'0' = 0V to +0.2V