

Features

- **Low Insertion Loss:** 0.9 dB @ 2.5 GHz
1.0 dB @ 3.5 GHz
- **Isolation:** 22 dB @ 2.5 GHz
20 dB @ 3.5GHz
- **Low DC Power Consumption**
- **Miniature UQFN8L (2x2x0.4 mm) Using Lead (Pb) free materials with RoHS compliant**
- **PHEMT process**

UQFN8L (2x2x0.4 mm)

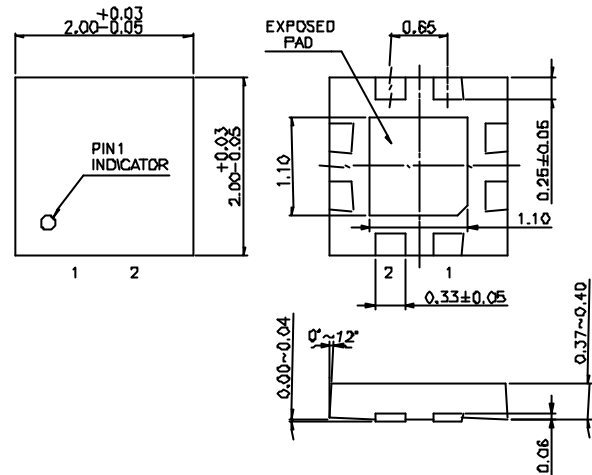

Unit:mm

Description

The HWS510 is a GaAs PHEMT MMIC DPDT switch operating at 0.5-4 GHz in a low cost miniature UQFN8L (2 x 2 x 0.4 mm) plastic lead (Pb) free package. The HWS510 features low insertion loss and high isolation with very low DC power consumption. This switch can be used in WiMAX or IEEE 802.11b/g WLAN systems for combination of transmit/receive and antenna diversity functions.

Electrical Specifications at 25°C with 0, +3V Control Voltages

Parameter	Test Conditions	Min.	Typ.	Max.	Unit
Insertion Loss	0.50-2.00 GHz		0.9	1.0	dB
	2.30-2.70 GHz		0.9	1.1	dB
	3.30-3.90 GHz		1.0	1.3	dB
Isolation (on-off or off-on)	0.50-2.00 GHz	25	27		dB
	2.30-2.70 GHz	20	22		dB
	3.30-3.90 GHz	17	20		dB
Return Loss	0.50-4.00 GHz		15		dB
Input Power for 1 dB Compression	2.00-4.00 GHz		36		dBm
Control Current			5	200	uA

Note: All measurements made in a 50 ohm system with 0/+3.0V control voltages, unless otherwise specified.

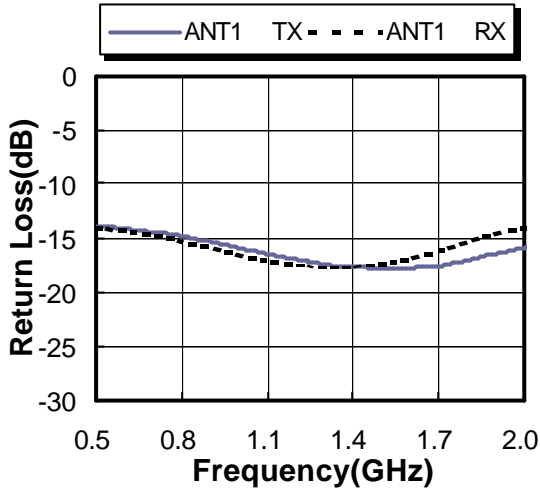
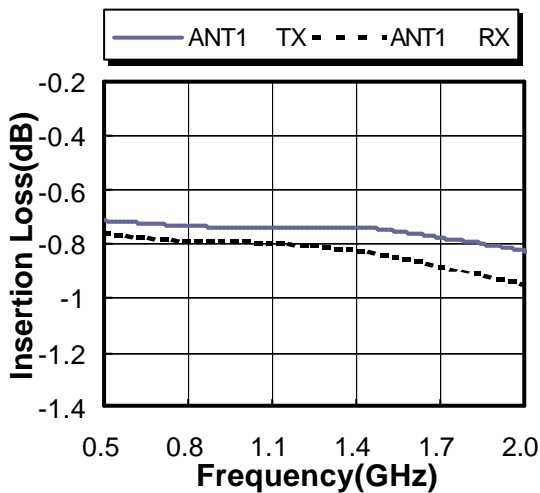
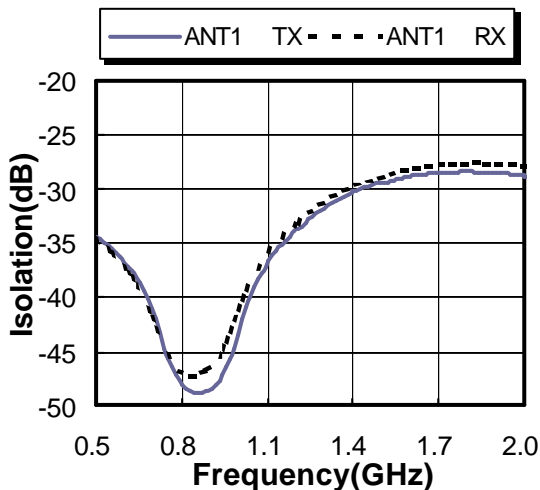
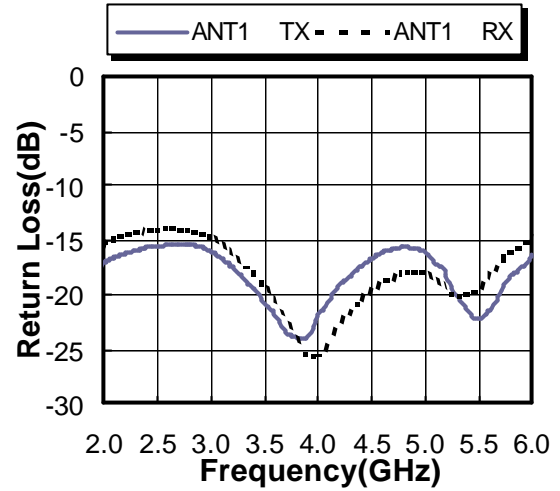
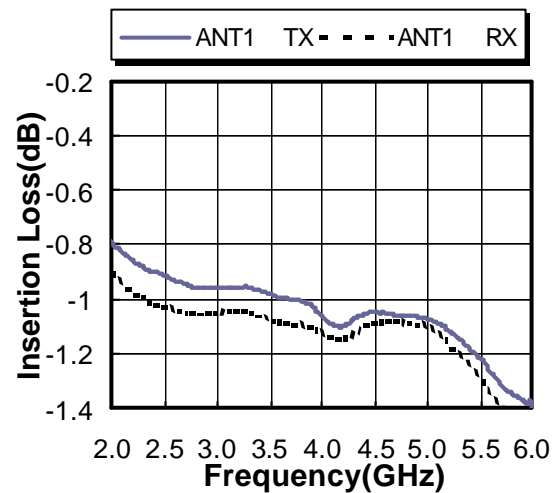
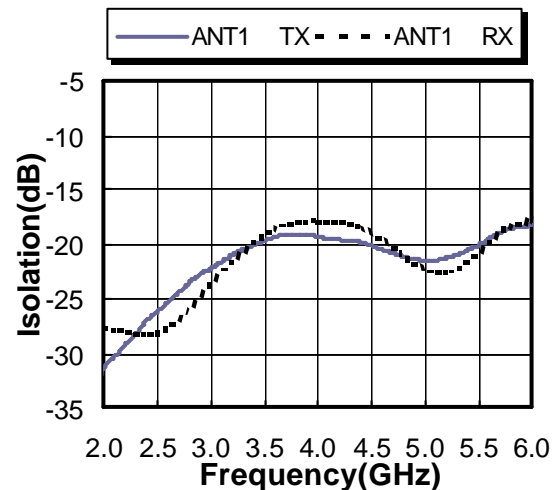
Typical Performance Data with 47pF Capacitors @ +25°C
Return Loss vs. Frequency

Insertion Loss vs. Frequency

Isolation vs. Frequency

Typical Performance Data with 8pF Capacitors @ +25°C
Return Loss vs. Frequency

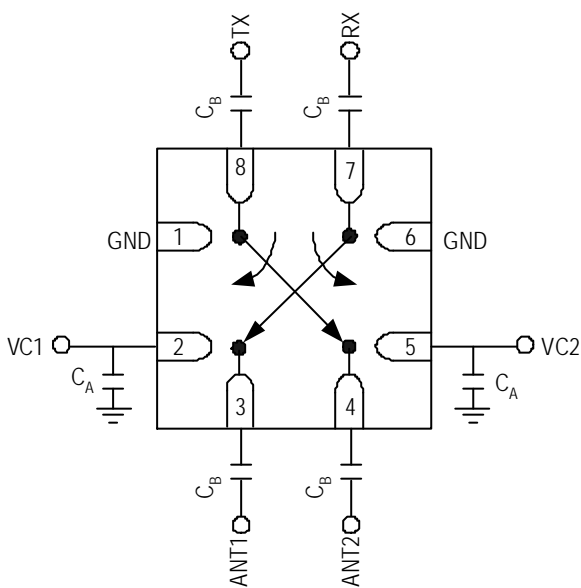
Insertion Loss vs. Frequency

Isolation vs. Frequency

Absolute Maximum Ratings

Parameter	Absolute Maximum
RF Input Power	+36 dBm @ +3V
Control Voltage	+6V
Operating Temperature	-40°C to +85°C
Storage Temperature	-65°C to +150°C

Pin Out



Note:

1. DC blocking capacitors $C_B=8\text{pF}$ are required at 2 – 6GHz on all RF ports.
2. DC blocking capacitors $C_B=47\text{pF}$ are required at 0.5 – 2GHz on all RF ports.
3. RF by-pass capacitors $C_A=8\text{pF}$ at 2 – 6GHz.
4. RF by-pass capacitors $C_A=47\text{pF}$ at 0.5 – 2GHz.

Logic Table for Switch On-Path

VC1	VC2	ANT1-RX	ANT1-TX	ANT2-TX	ANT2-RX
1	0	On	Off	On	Off
0	1	Off	On	Off	On
1	1	Off	Off	Off	Off
0	0	Off	Off	Off	Off

'1' = +3V to +5V
'0' = 0V to +0.2V