

Features

- **Low Insertion Loss:** 0.45 dB @ 1.0 GHz
0.60 dB @ 2.5 GHz
- **Isolation:** 30.0 dB @ 1.0 GHz
28.0 dB @ 2.5 GHz
- **Low DC Power Consumption**
- **Miniature USON6L (1.5x1.5x0.4 mm)**
Using Lead (Pb) free materials with RoHS compliant
- **PHEMT process**

Description

The HWS525 is a GaAs PHEMT MMIC SPDT switch operating at 0.5-3.0 GHz in a low cost miniature USON6L (1.5x1.5x0.4 mm) plastic lead (Pb) free package. The HWS525 features low insertion loss and high isolation with very low DC power consumption. This switch can be used in WiMAX or IEEE 802.11b/g/n WLAN PC card and access point applications as transmit/receive switch, antenna diversity switch, or band-selection switch.

USON6L (1.5x1.5X0.4 mm)

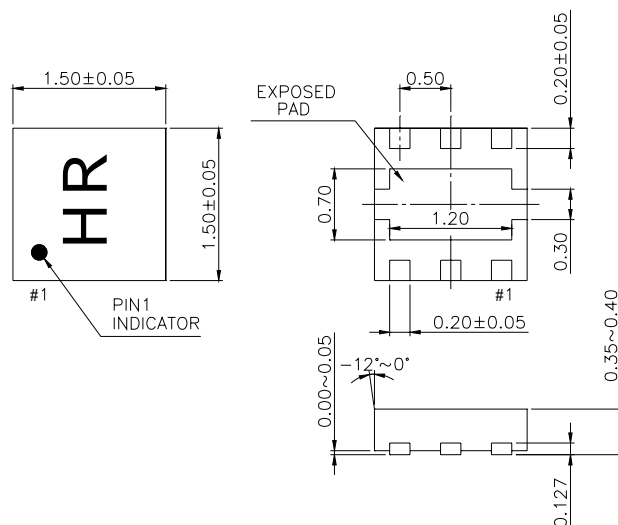

Unit:mm

Electrical Specifications at 25°C with 0, +3V Control Voltages

Parameter	Test Conditions	Min.	Typ.	Max.	Unit
Insertion Loss	0.5-1.0 GHz		0.45		dB
	1.0-2.0 GHz		0.50	0.60	dB
	2.0-3.0 GHz		0.60	0.80	dB
Isolation	0.5-1.0 GHz		30.0		dB
	1.0-2.0 GHz	25.0	28.0		dB
	2.0-3.0 GHz	25.0	28.0		dB
Return Loss	0.5-3.0 GHz		18		dB
Input Power for 0.1 dB Compression	0.50-3.00 GHz @0/+1.8V @0/+3.0V		30		dBm
			36		dBm
Second Harmonic	Pin=30 dBm, f=0.9 GHz		-65		dBc
Third Harmonic	Pin=30 dBm, f=0.9 GHz		-65		dBc
Switching Time	10% to 90%, 90% to 10% RF		100		nsec
Control Current			5	100	uA

Note: All measurements made in a 50 ohm system with 0/+3.0V control voltages, unless otherwise specified.

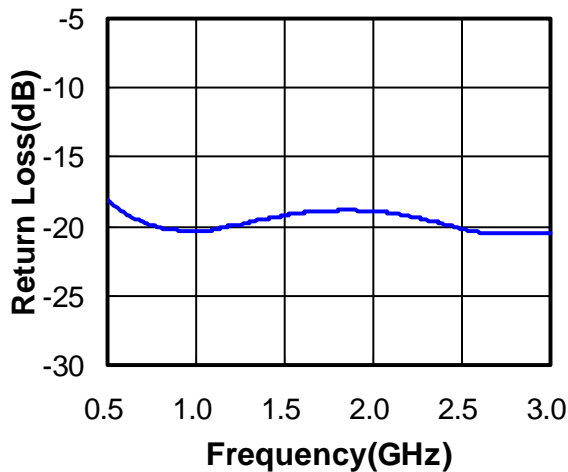
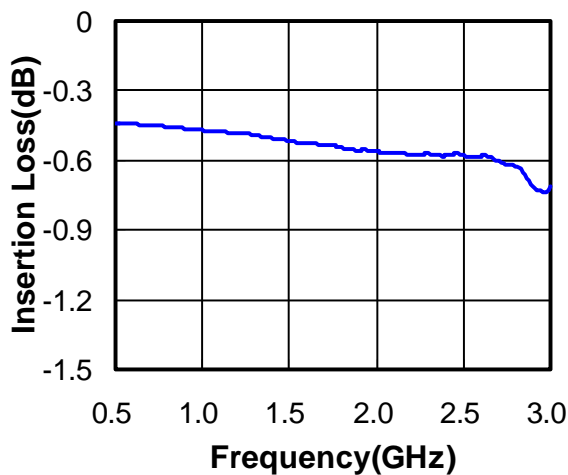
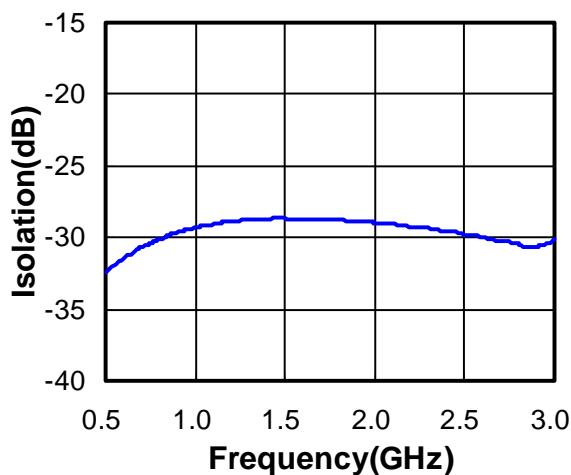
Typical Performance Data with 47pF Capacitors @ +25°C
Return Loss vs. Frequency

Insertion Loss vs. Frequency

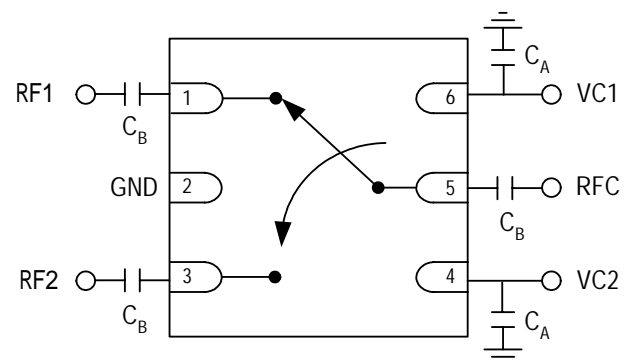
Isolation vs. Frequency

Absolute Maximum Ratings

Parameter	Absolute Maximum
RF Input Power	+36 dBm @ +3V
Control Voltage	+6V
Operating Temperature	-40°C to +85°C
Storage Temperature	-65°C to +150°C
Electrostatic Discharge Machine Model	Class M1

Pin Out (Top View)

Note:

1. DC blocking capacitors $C_B=47\text{pF}$ are required on all RF ports.
2. RF by-pass capacitors $C_A=47\text{pF}$.
3. Exposed pad in the bottom must be connected to ground by via holes.

Logic Table for Switch On-Path

VC1	VC2	RFC-RF1	RFC-RF2
1	0	On	Off
0	1	Off	On

'1' = +1.8V to +5V

'0' = 0V to +0.2V