



Features

- Up to 95% Efficiency
- Current Mode Operation for Excellent Line and Load Transient Response
- Low Quiescent Current: 200μA
- Output Voltage: 0.6V ~ 5.5V
- Automatic PWM/PFM Mode Switching
- No Schottky Diode Required
- Frequency Operation: 1.0MHz For Fixed Output Voltage and 1.4MHz For Adjustable Output Voltage and
- Short-Circuit Protection
- Shutdown Quiescent Current: < 1μA
- Low Profile SOT-23-5L Package (lead-free packaging is now available)

Applications

- Digital cameras and MP3
- Palmtop computers / PDAs
- Cellular phones
- PC cards
- Portable media players

Description

The HX1002 is high efficiency synchronous, PWM step-down DC/DC converters working under an input voltage range from 2.2V to 5.5V. This feature makes the HX1002 suitable for single Li-Lon battery-powered applications. 100% duty cycle capability extends battery life in portable devices, while the quiescent current is 200μA with no load, and drops to <1μA in shutdown.

The internal synchronous switch is desired to increase efficiency without an external Schottky diode. The 1.0/1.4MHz switching frequency allows the using of tiny, low profile inductors and ceramic capacitors, which minimized overall solution footprint.

The HX1002 converters are available in the industry standard SOT-23-5L power packages (or upon request).

Order Information

HX1002 – ① ②:

| SYMBOL | DESCRIPTION |
|--------|---|
| ① | Denotes Output Voltage: A : Adjustable Output K : 1.2V B : 1.5V C : 1.8V G : 3.3 V |
| ② | Denotes Package Type: E: SOT-23-5L |

Typical Application Circuit

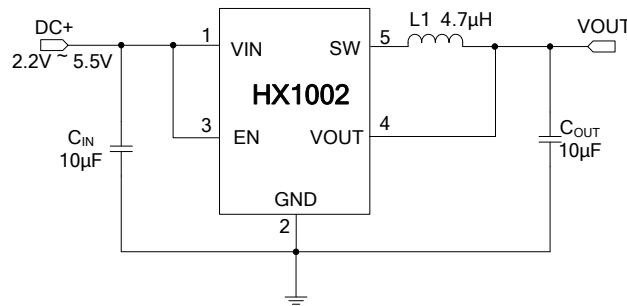
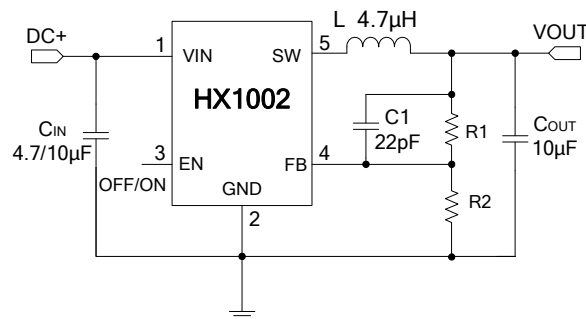

Figure 1: Fixed Voltage Converter



$$*V_{OUT} = 0.6V \cdot [1 + (R1/R2)]$$

Figure 2: Adjustable Voltage Converter

| Model | VOUT (V) | VIN (V) |
|------------|-----------|-----------|
| HX 1002-AE | 0.6 ~ 5.5 | 2.5 ~ 5.5 |
| HX1002-KE | 1.2 | 2.2 ~ 5.5 |
| HX1002-BE | 1.5 | 2.5 ~ 5.5 |
| HX1002-CE | 1.8 | 2.5 ~ 5.5 |
| HX1002-GE | 3.3 | 3.4 ~ 5.5 |

Pin Assignment and Description

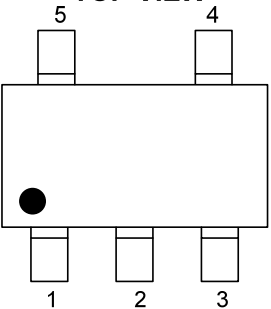
| TOP VIEW | | PIN | NAME | DESCRIPTION |
|---|--|-----|---------|-----------------------------|
|  | | 1 | VIN | Input |
| | | 2 | GND | Ground |
| | | 3 | EN | ON/OFF Control(High Enable) |
| | | 4 | VOUT/FB | Feedback |
| | | 5 | SW | Switch Output |

Absolute Maximum Ratings (Note 1)

- Power Dissipation.....Internally limited
- V_{IN} -0.3V ~ +6V
- V_{EN} -0.3V ~ ($V_{IN} + 0.3$)V
- V_{SW} -0.3V ~ ($V_{IN} + 0.3$)V
- V_{OUT}-0.3V ~ + 6V
- I_{SW} 1.3A
- Operating Temperature Range(Note 2).....-40°C ~ +85°C
- Lead Temperature (Soldering, 10 sec.)+265°C
- Storage Temperature Range-65°C ~ +150°C
- Junction Temperature-40°C ~ +125°C

Note 1: Stresses listed as the above “Absolute Maximum Ratings” may cause permanent damage to the device.

Exposure to absolute maximum rating conditions for extended periods may remain possibility to affect device reliability.

Note 2: The HX1002 is guaranteed to meet performance specifications from 0°C to 85°C. Specifications over the -40°C to 85°C operating temperature range are assured by design, characterization and correlation with statistical process controls.

Electrical Characteristics

Operating Conditions: $T_A=25^{\circ}\text{C}$, $V_{IN} = V_{OUT}+0.5\text{V}$, unless otherwise specified.

| SYMBOL | PARAMETER | CONDITIONS | MIN | TYP | MAX | UNITS |
|-------------------|---|--|-------|------|----------|---------------|
| ΔV_{OUT} | Output Voltage Accuracy (For Fixed Output Voltage) | $I_{OUT}=100\text{mA}$ | -2 | | +2 | % |
| V_{OUT} | Adjustable Output Range | | 0.6 | | 5.5 | V |
| V_{FB} | Regulated Voltage | $T_A = 25^{\circ}\text{C}$, | 0.588 | 0.6 | 0.612 | V |
| I_{FB} | Feedback Current | | | | ± 30 | nA |
| ΔV_{FB} | V_{REF} | $V_{IN} = 2.5\text{V} \sim 5.5\text{V}$ | | 0.03 | 0.4 | %/V |
| f_{OSC} | Oscillator Frequency | $V_{OUT} = 100\%$ For Fixed Output Voltage | | 1 | | MHz |
| | | $V_{FB} = 0.6\text{V}$ For Adjustable Output Voltage | | 1.4 | | MHz |
| I_Q | Quiescent Current | $V_{FB} = 0.5\text{V}$ or $V_{OUT} = 90\%$, $I_{LOAD} = 0\text{A}$ | | 200 | 300 | μA |
| I_{SHTD} | Shutdown Current | $V_{EN} = 0\text{V}$, $V_{IN} = 4.2\text{V}$ | | 0.1 | 1 | μA |
| I_{PK} | Peak Inductor Current | $V_{IN} = 3\text{V}$, $V_{FB} = 0.5\text{V}$ or $V_{OUT} = 90\%$, | 0.75 | 0.9 | 1 | A |
| R_{PFET} | $R_{DS(ON)}$ of P-Channel FET | $I_{SW} = 100\text{mA}$ | | 0.3 | | Ω |
| R_{NFET} | $R_{DS(ON)}$ of N-Channel FET | $I_{SW} = -100\text{mA}$ | | 0.39 | | Ω |
| EFFI | Efficiency | When connected to extra components, $V_{IN} = V_{EN} = 2.7\text{V}$, $V_{OUT}=2.5\text{V}$, $I_{OUT}=100\text{mA}$ | | 95 | | % |
| ΔV_{OUT} | V_{OUT} Line Regulation | $V_{IN} = (V_{OUT}+0.5\text{V})$ to 5.5V | | 0.03 | 0.3 | %/V |
| ΔV_{LOAD} | V_{OUT} Load Regulation | $0\text{mA} \leq I_{OUT} \leq 100\text{mA}$ | | 0.33 | | % |

Typical Performance Characteristics

**Efficiency vs. Output Current
(Vout=1.2V)**

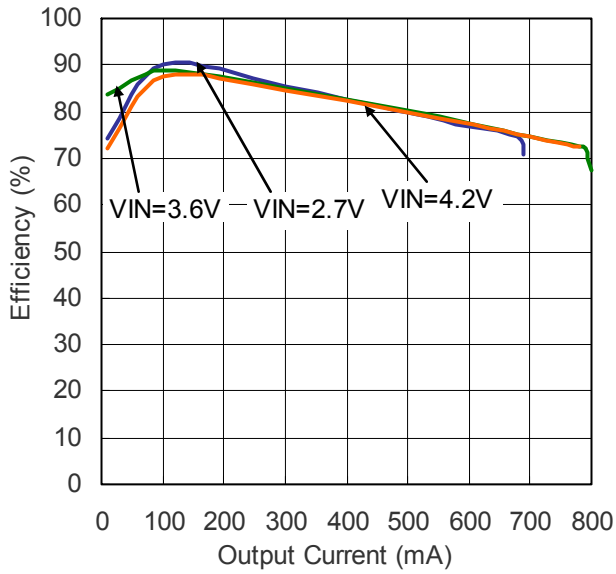

**Output Voltage vs. Load Current
(Vin=3.6V, Vout=1.2V)**

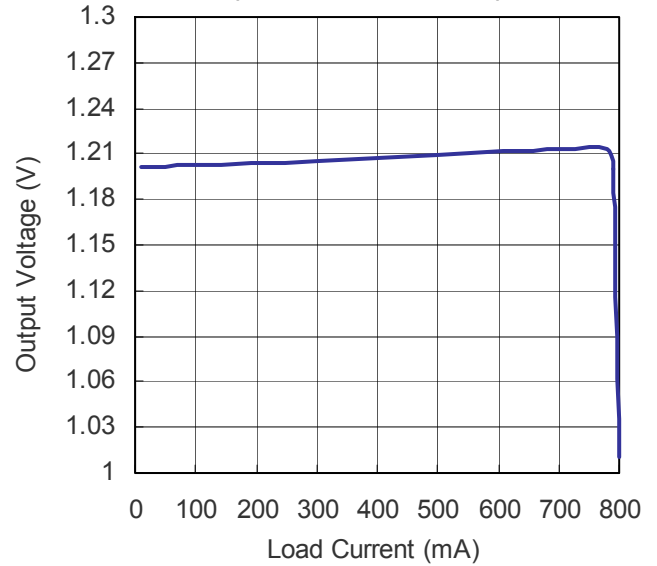

**Efficiency vs. Output Current
(Vout=1.8V)**

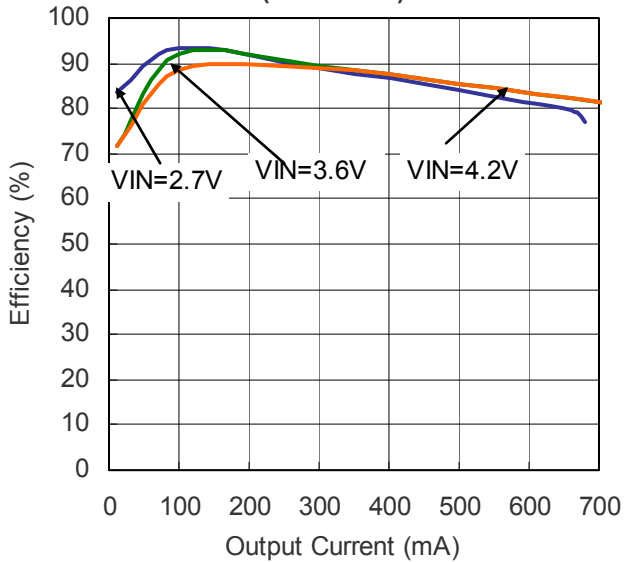

**Output Voltage vs. Load Current
(Vin=3.6V, Vout=1.8V)**

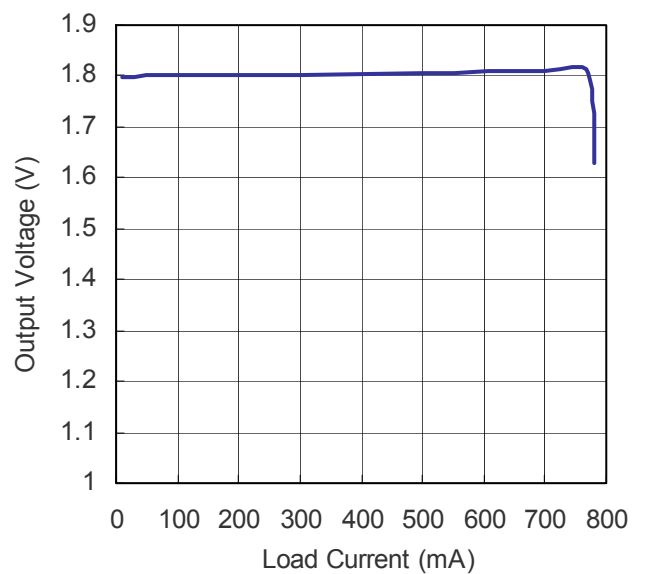

Supply Current vs. Supply Voltage
($V_{out}=1.8V$ $I_o=0A$)

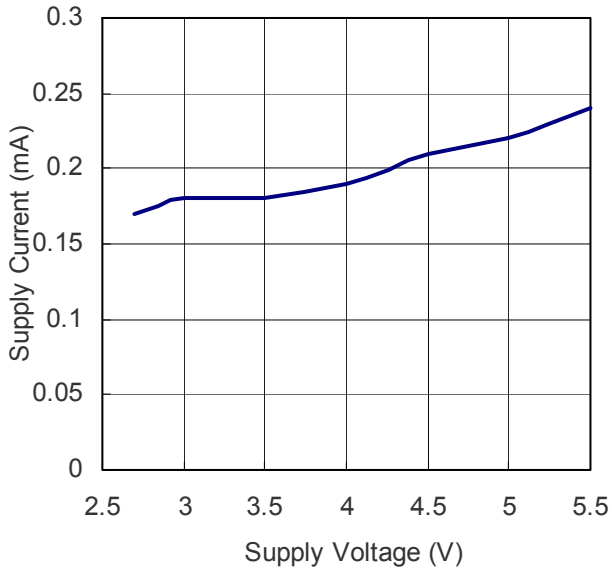

Start –up from Shutdown
(1.00V/div 1.00V/div 100 μ s/div)

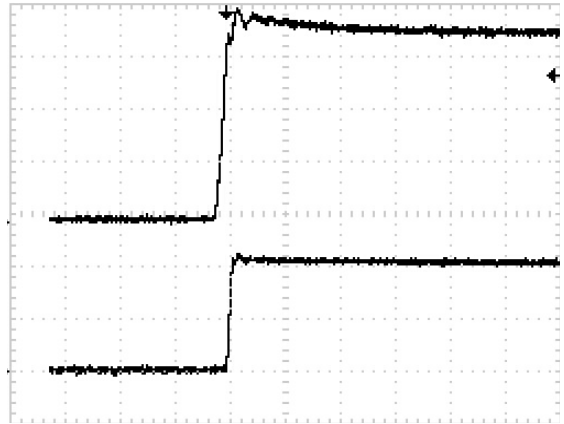

$V_{IN}=3.6V$ $V_{OUT}=1.8V$ $I_{LOAD}=0mA$

Output Noise (10mV/DIV 200ns/DIV
AC COUPLED)

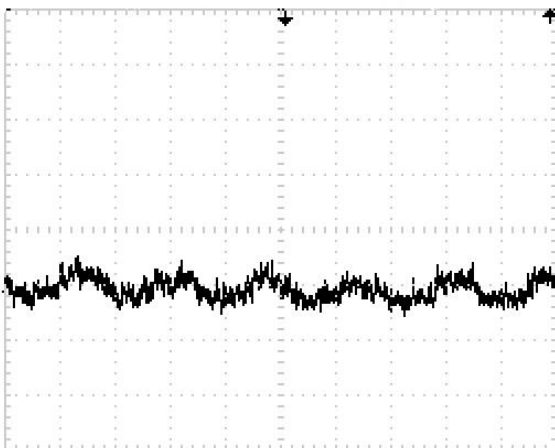

$V_{IN}=3.6V$ $V_{OUT}=1.8V$ $I_{LOAD}=200mA$

Output Noise (100mV/DIV 2ms/DIV
AC COUPLED)

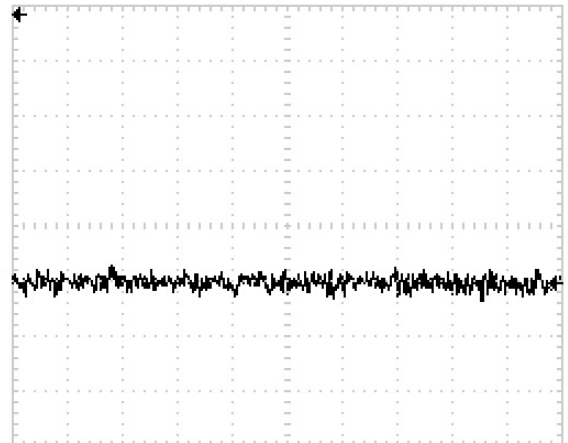

$V_{IN}=3.6V$ $V_{OUT}=1.8V$ $I_{LOAD}=0mA$

Pin Functions

VIN (Pin 1): Main Supply Pin. A 10 μ F ceramic VIN capacitor recommended must be closely decoupled to GND.

GND (Pin 2): Ground Pin.

EN (Pin 3): EN Control Input. Forcing this pin above 1.3V enables the part. Forcing this pin below 0.7V can shut down the device. In shutdown, all functions are disabled drawing <1 μ A supply current. Do not leave EN floating.

VOUT/FB (Pin 4): Feedback Pin. In the nonadjustable version, the output voltage is fixed. In the adjustable version, the output voltage is set by a resistive divider according to the following formula:
 $V_{OUT} = 0.6V \cdot [1 + (R1/R2)]$.

SW (Pin 5): Switch Node Connection to Inductor. This pin connects to the drains of the internal main and synchronous power MOSFET switches.

Application Information

The basic HX1002 application circuit is shown in Typical Application Circuit. External component selection is determined by the maximum load current and begins with the selection of the inductor value and operating frequency followed by C_{IN} and C_{OUT} .

Inductor Selection

For most applications, the value of the inductor will fall in the range of $1\mu\text{H}$ to $4.7\mu\text{H}$. Its value is chosen based on the desired ripple current. Large value inductors lower ripple current and small value inductors result in higher ripple currents. Higher V_{IN} or V_{OUT} also increases the ripple current as shown in the equation. A reasonable starting point for setting ripple current is $\Delta I_L = 280\text{mA}$ (40% of 700mA).

$$\Delta I_L = \frac{1}{(f)(L)} V_{OUT} \left(1 - \frac{V_{OUT}}{V_{IN}} \right)$$

The DC current rating of the inductor should be at least equal to the maximum load current plus half the ripple current to prevent core saturation. Thus, a 840mA rated inductor should be enough for most applications (700mA + 140mA). For better efficiency, choose a low DC-resistance inductor.

Different core materials and shapes will change the size/current and price/current relationship of an inductor. Toroid or shielded pot cores in ferrite or perm alloy materials are small and don't radiate much energy, but generally cost more than powdered iron core inductors with similar electrical characteristics. The choice of which style inductor to use often depends more on the price vs. size requirements and any radiated field/EMI requirements than on what the HX1002 requires to operate.

Output and Input Capacitor Selection

In continuous mode, the source current of the top MOSFET is a square wave of duty cycle V_{OUT}/V_{IN} . To prevent large voltage transients, a low ESR input capacitor sized for the maximum RMS current must be used. The maximum RMS capacitor current is given by:

$$C_{IN} \text{ required } I_{RMS} \cong I_{OMAX} \frac{[V_{OUT}(V_{IN} - V_{OUT})]^{1/2}}{V_{IN}}$$

This formula has a maximum at $V_{IN} = 2V_{OUT}$, where $I_{RMS} = I_{OUT}/2$. This simple worst-case condition is commonly used for design because even significant deviations do not offer much relief. Note that the capacitor manufacturer's ripple current ratings are often based on 2000 hours of life. This makes it advisable to further derate the capacitor, or choose a capacitor rated at a higher temperature than required. Always consult the manufacturer if there is any question.

The selection of C_{OUT} is driven by the required effective series resistance (ESR).

Typically, once the ESR requirement for C_{OUT} has been met, the RMS current rating generally far exceeds the $I_{RIPPLE(P-P)}$ requirement. The output ripple ΔV_{OUT} is determined by:

$$\Delta V_{OUT} \cong \Delta I_L \left(\text{ESR} + \frac{1}{8fC_{OUT}} \right)$$

Where f = operating frequency, C_{OUT} = output capacitance and ΔI_L = ripple current in the inductor. For a fixed output voltage, the output ripple is highest at maximum input voltage since ΔI_L increases with input voltage.

Aluminum electrolytic and dry tantalum capacitors are both available in surface mount configurations. In the case of tantalum, it is critical that the capacitors are surge tested for use in switching power supplies. An excellent choice is the AVX TPS series of surface mount tantalum. These are specially constructed and tested for low ESR so they give the lowest ESR for a given volume. Other capacitor types include Sanyo POSCAP, Kemet T510 and T495 series, and Sprague 593D and 595D series. Consult the manufacturer for other specific recommendations.

Efficiency Considerations

The efficiency of a switching regulator is equal to the output power divided by the input power times 100%. It is often useful to analyze individual losses to determine what is limiting the efficiency and which change would produce the most improvement. Efficiency can be expressed as: Efficiency = 100% - (L1+ L2+ L3+ ...) where L1, L2, etc. are the individual losses as a percentage of input power. Although all dissipative elements in the circuit produce losses, two main sources usually account for most of the losses: VIN quiescent current and I^2R losses. The VIN quiescent current loss dominates the efficiency loss at very low load currents whereas the I^2R loss dominates the efficiency loss at medium to high load currents. In a typical efficiency plot, the efficiency curve at very low load currents can be misleading since the actual power lost is of no consequence.

1. The VIN quiescent current is due to two components: the DC bias current as given in the electrical characteristics and the internal main switch and synchronous switch gate charge currents. The gate charge current results from switching the gate capacitance of the internal power MOSFET switches. Each time the gate is switched from high to low to high again, a packet of charge ΔQ moves from VIN to ground. The resulting $\Delta Q/\Delta t$ is the current out of VIN that is typically larger than the DC bias current. In continuous mode, $I_{GATECHG} = f(Q_T + Q_B)$ where Q_T and Q_B are the gate charges of the internal top and bottom switches. Both the DC bias and gate charge losses are proportional to VIN and thus their effects will be more pronounced at higher supply voltages.

2. I^2R losses are calculated from the resistances of the internal switches, R_{SW} and external inductor R_L . In continuous mode the average output current flowing through inductor L is “chopped” between the main switch and the synchronous switch. Thus, the series resistance looking into the SW pin is a function of both top and bottom MOSFET $R_{DS(ON)}$ and the duty cycle (DC) as follows: $R_{SW} = R_{DS(ON)TOP} \times DC + R_{DS(ON)BOT} \times (1-DC)$ The $R_{DS(ON)}$ for both the top and bottom MOSFETs can be obtained from the Typical Performance Characteristics curves. Thus, to obtain I^2R losses, simply add R_{SW} to R_L and multiply the result by the square of the average output current. Other losses including C_{IN} and C_{OUT} ESR dissipative losses and inductor core losses generally account for less than 2% of the total loss.

PCB Layout Guidelines

When laying out the printed circuit board, the following checklist should be used to ensure proper operation of the HX1002. Check the following in your layout:

1. The power traces, consisting of the GND trace, the SW trace and the V_{IN} trace should be kept short, direct and wide.
2. Put the input capacitor as close as possible to the device pins (V_{IN} and GND).
3. SW node is with high frequency voltage swing and should be kept small area. Keep analog components away from SW node to prevent stray capacitive noise pick-up.
4. Connect all analog grounds to a command node and then connect the command node to the power ground behind the output capacitors.
5. Keep the (-) plates of C_{IN} and C_{OUT} as close as possible.

Packaging Information

SOT-23-5L Package Outline Dimension

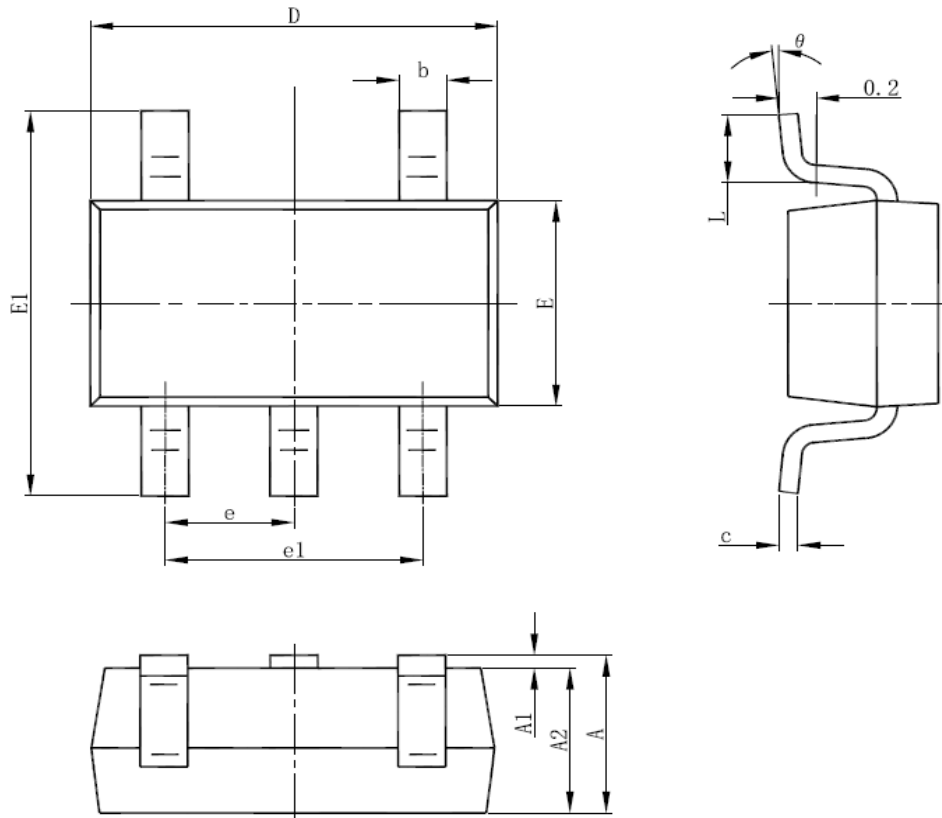

| Symbol | Dimensions In Millimeters | | Dimensions In Inches | |
|--------|---------------------------|-------|----------------------|-------|
| | Min | Max | Min | Max |
| A | 1.050 | 1.250 | 0.041 | 0.049 |
| A1 | 0.000 | 0.100 | 0.000 | 0.004 |
| A2 | 1.050 | 1.150 | 0.041 | 0.045 |
| b | 0.300 | 0.500 | 0.012 | 0.020 |
| c | 0.100 | 0.200 | 0.004 | 0.008 |
| D | 2.820 | 3.020 | 0.111 | 0.119 |
| E | 1.500 | 1.700 | 0.059 | 0.067 |
| E1 | 2.650 | 2.950 | 0.104 | 0.116 |
| e | 0.950(BSC) | | 0.037(BSC) | |
| e1 | 1.800 | 2.000 | 0.071 | 0.079 |
| L | 0.300 | 0.600 | 0.012 | 0.024 |
| θ | 0° | 8° | 0° | 8° |

Subject changes without notice