



PROPRIETARY NOTE

THIS SPECIFICATION IS THE PROPERTY OF HYDIS AND SHALL NOT BE REPRODUCED OR COPIED WITHOUT THE WRITTEN PERMISSION OF HYDIS AND MUST BE RETURNED TO HYDIS UPON ITS REQUEST

TITLE : HX121WX1-111
Product Specification
Rev. 0

HYDIS Technologies

SPEC. NUMBER	PRODUCT GROUP	REV.	ISSUE DATE	PAGE
S864-1419	TFT LCD	0	2010. 10.21	1 OF 34



PRODUCT GROUP

REV

ISSUE DATE

TFT LCD PRODUCT

0

2010. 10.21

REVISION HISTORY

REV.	ECN NO.	DESCRIPTION OF CHANGES	DATE	PREPARED
0	-	▪ Initial Release	'10. 10.21	H.J. Ahn

--	--	--	--	--

SPEC. NUMBER S864-1419	SPEC TITLE HX121WX1-111 Product Specification	PAGE 2 OF 34
---------------------------	--	-----------------



PRODUCT GROUP

REV

ISSUE DATE

TFT LCD PRODUCT

0

2010. 10.21

Contents

No	Item	Page
1.0	General Description	4
2.0	Absolute Maximum Ratings	6
3.0	Electrical Specifications	7
4.0	Optical Specifications	9
5.0	Interface Connections	14
6.0	Signal Timing Specifications	17
7.0	Signal Timing Waveforms	17
8.0	Input Signals, Basic Display Colors & Gray Scale of Colors	19
9.0	Power Sequence	20
10.0	Mechanical Characteristics	21
11.0	Mechanical Drawing	22
12.0	Reliability Test	25
13.0	Handling & Cautions	25
14.0	Labels	27
15.0	Packing Information	29
16.0	EDID	31

SPEC. NUMBER
S864-1419SPEC TITLE
HX121WX1-111 Product SpecificationPAGE
3 OF 34

1.0 GENERAL DESCRIPTION

1.1 Introduction

HX121WX1-111 is a color active matrix TFT LCD module using amorphous silicon TFT's (Thin Film Transistors) as an active switching devices. This module has a 12.1 inch diagonally measured active area with WXGA resolutions (1280 horizontal by 800 vertical pixel array). Each pixel is divided into RED, GREEN, BLUE dots which are arranged in vertical Stripe and this module can display 262,144 colors. The TFT-LCD panel used for this module is a low reflection and higher color type.

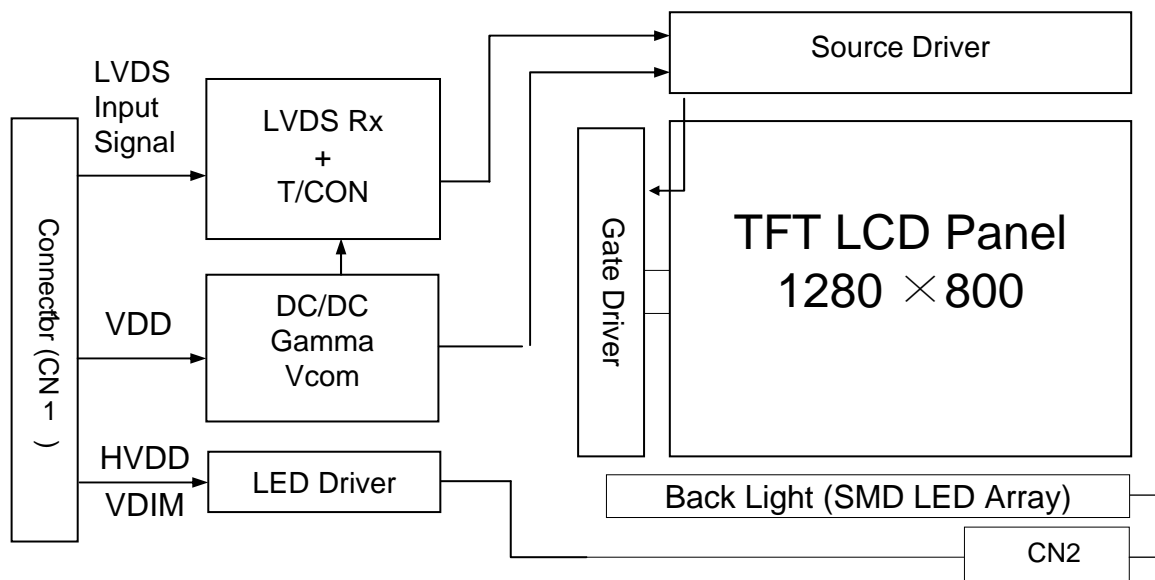

1.2 Features

- Thin and Light Weight
- 3.3 V Logic Power Supply
- 12V Back-light Power Supply
- 1 Channel LVDS Interface
- SMD LED (48EA) Array (Bottom Side/Horizontal Direction)
- 262,144 Colors
- Data Enable Signal Mode
- Side Mounting Frame
- Green Product (RoHS)



PRODUCT GROUP

REV

ISSUE DATE

TFT LCD PRODUCT

0

2010. 10.21

1.3 Application

- Tablet PC (Wide type)

1.4 General Specifications

Parameter	Specification	Unit	Remarks
Active area	261.12(H) × 163.20(V)	mm	
Number of pixels	1280(H) × 800(V)	pixels	
Pixel pitch	0.204(H) × 0.204(V)	mm	
Pixel arrangement	RGB Vertical Stripe		
Display colors	262,144	colors	
Display mode	Normally Black		
Outline dimension	276.8±0.3(H) × 180.0±0.3(V) × 6.8(D:Max.)	mm	Note 1
Weight	265(Typ.) / 275(Max.)	g	Note 2
Back-light	SMD LED (48EA) Array		
Surface treatment	Anti-Glare (Haze 40%)		

Note 1 : At PCB side (LED Side: 4.6mm Max.)

Note 2 : Without digitizer

SPEC. NUMBER
S864-1419

SPEC TITLE
HX121WX1-111 Product Specification

PAGE
5 OF 34

2.0 ABSOLUTE MAXIMUM RATINGS

The followings are maximum values which, if exceed, may cause faulty operation or damage to the unit.

Ta=25+/-2°C

Parameter	Symbol	Min.	Max.	Unit	Remarks
Logic Power Supply Voltage	V _{DD}	-0.3	4.0	V	
Logic Power Supply Voltage	V _{IN}	-0.3	V _{DD} +0.3	V	
Back-light Power Supply Voltage	HV _{DD}	-0.3	28	V	
Back-light LED Current	I _{LED}	-	27	mA	Note 1
Back-light LED Reverse Voltage	V _R	-	5	V	
Operating Temperature	T _{OP}	0	+50	°C	Note 1, Note 2
Storage Temperature	T _{SP}	-20	+60	°C	

Note 1. Ambient temperature vs allowable forward current are shown in the figure below.

Note 2. Temperature and relative humidity range are shown in the figure below.

95% RH Max. (40°C ≥ Ta)

Maximum wet - bulb temperature at 39°C or less. (> 40°C) No condensation.

Ambient Temperature vs. Maximum Forward Current

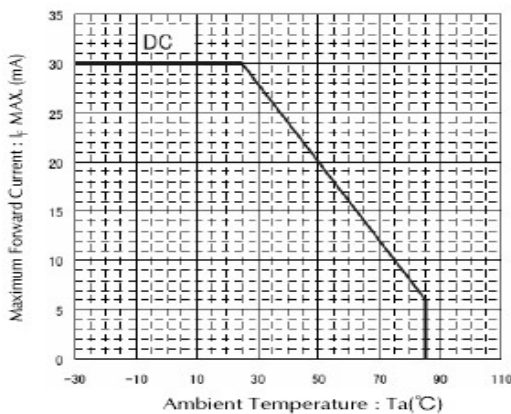

Relative Humidity (%RH)

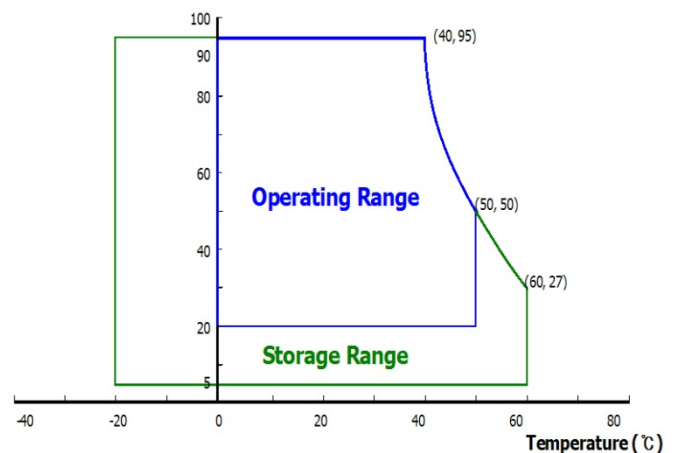

3.0 ELECTRICAL SPECIFICATIONS

3.1 Electrical Specifications

< Table 3. Electrical Specifications >

Parameter		Min.	Typ.	Max.	Unit	Remarks
Logic Power Supply Voltage	V_{DD}	3.0	3.3	3.6	V	Note 1
Logic Power Supply Current	I_{DD}	-	300	470	mA	Note 1
Back-light Power Supply Voltage	HV_{DD}	7.0	12.0	21	V	Note 2
Back-light Power Supply Current	I_{HVDD}	-	255	305	mA	Note 2, 3
Back-light Power Consumption	P_{BL}	-	3.06	2.94	W	Note 2, 3
LED Driver's Efficiency	η	-	82	-	%	Note 2, 3
Back-light PWM Frequency	F_{PWM}	150	254.5	350	Hz	
Back-light Duty ratio		1.9		100	%	
High Level PWM Signal Voltage	V_{PWMH}	2.1	3.3	5.0	V	
Low Level PWM Signal Voltage	V_{PWML}	-	0	0.6	V	
High Level Differential Input Signal Voltage	V_{IH}	-	-	+100	mV	$V_{CM} = 1.2V$
Low Level Differential Input Signal Voltage	V_{IL}	-100	-	-	mV	
Back-light LED Voltage / Back-light LED Total Voltage	V_{LED} / V_{BL}	-	3.2 / 38.4	3.4 / 40.8	V	Note 4
Back-light LED Current / Back-light LED Total Current	I_{LED} / I_{BL}	-	18.0 / 72.0	19.0 / 76.0	mA	Note 4
Life Time		12,000	-	-	Hrs	Note 6
Power Consumption	P_D	-	1.0	1.55	W	Note 1
	P_{LED}	-	2.76	3.10	W	Note 4
	P_{total}	-	3.76	4.65	W	Note 1, 4

- Notes : 1. The supply voltage is measured and specified at the interface connector of LCM.
 The current draw and power consumption specified is for 3.3V at 25°C.
 a) Typ : Window XP pattern, b) Max : Vertical Sub line pattern
2. The power supply voltage and current is measured and specified at the interface connector of LCM including LED Driver.
3. Reference value, which is measured with LED Driver for 12V.
4. Reference value, which is measured without LED Driver.
5. Calculated value for reference ($V_{LED} \times I_{LED} \times \# \text{ of LEDs (48EA)}$).
6. End of Life shall be determined by the time when any of the following is satisfied under continuous lighting at 25°C and $I_{LED} = 18.0\text{mA}$.
- . Intensity drops to 50% of the Initial Value (Luminance Spec.)
 - . Based on LED

3.2 PWM Duty Ratio vs Brightness

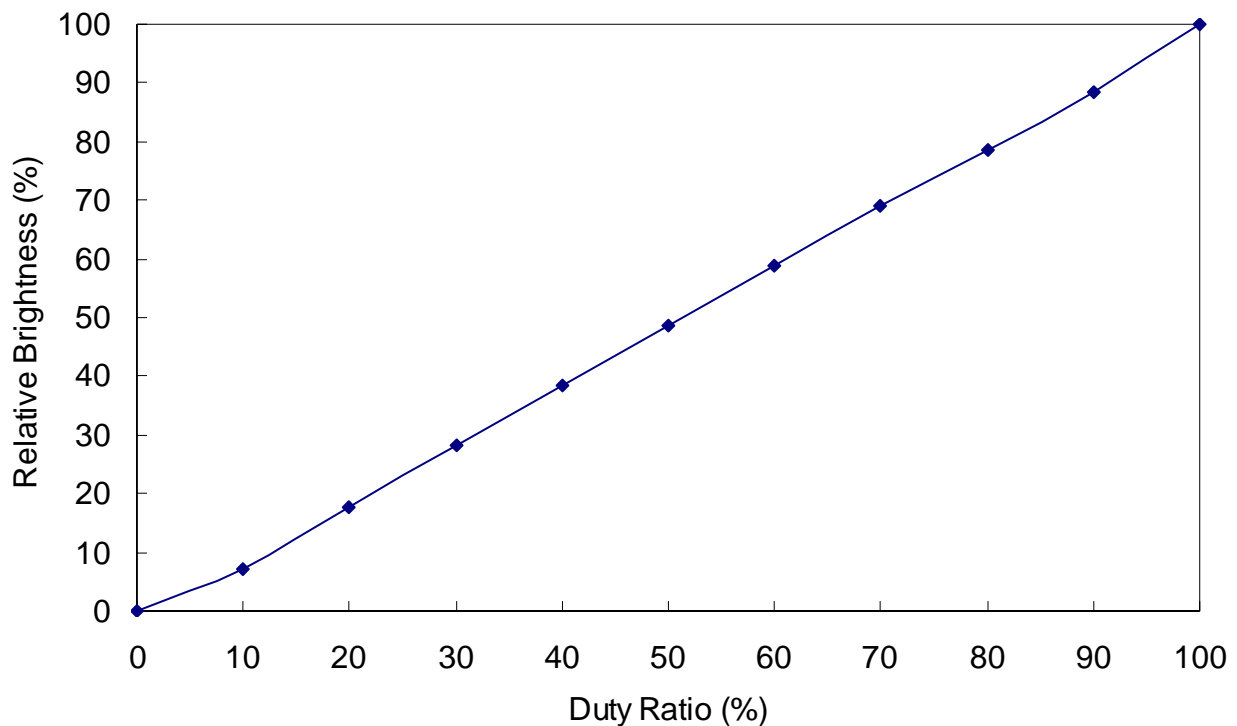

4.0 OPTICAL SPECIFICATIONS

4.1 Overview

The test of optical specifications shall be measured in a dark room (ambient luminance ≤ 1 lux and temperature = $25 \pm 2^\circ\text{C}$) with the equipment of Luminance meter system (Goniometer system and TOPCON BM-5A) and test unit shall be located at an approximate distance 50cm from the LCD surface at a viewing angle of Θ and Φ equal to 0° . We refer to $\Theta_{\varnothing=0}$ ($=\Theta_3$) as the 3 o'clock direction (the "right"), $\Theta_{\varnothing=90}$ ($=\Theta_{12}$) as the 12 o'clock direction ("upward"), $\Theta_{\varnothing=180}$ ($=\Theta_9$) as the 9 o'clock direction ("left") and $\Theta_{\varnothing=270}$ ($=\Theta_6$) as the 6 o'clock direction ("bottom"). While scanning Θ and/or Φ , the center of the measuring spot on the Display surface shall stay fixed. The backlight should be operating for 30 minutes prior to measurement. V_{DD} shall be $3.3 \pm 0.3\text{V}$ at 25°C . Optimum viewing angle direction is 6 o'clock.

4.2 Optical Specifications

<Table 4. Optical Specifications>

Parameter		Symbol	Condition	Min.	Typ.	Max.	Unit	Remarks
Viewing Angle Range	Horizontal	Θ_3	CR > 10	-	90	-	Deg.	Note 1
		Θ_9		-	90	-	Deg.	
	Vertical	Θ_{12}		-	90	-	Deg.	
		Θ_6		-	90	-	Deg.	
Luminance Contrast Ratio		CR		500	700	-		Note 2
Luminance of White	5 Points	Y_w		170	200	-	cd/m ²	
White Luminance Uniformity	5 Points	$\Delta Y5$		80	-	-	%	Note 3
	13 Points	$\Delta Y13$		60	-	-		
Color Chromaticity	White	W_x	$\Theta = 0^\circ$	0.283	0.313	0.343		Note 4
		W_y		0.299	0.329	0.359		
	Red	R_x		0.547	0.577	0.607		
		R_y		0.339	0.369	0.399		
	Green	G_x		0.319	0.349	0.379		
		G_y		0.539	0.569	0.599		
	Blue	B_x		0.120	0.150	0.180		
		B_y		0.092	0.122	0.152		
Color Reproduction					45		%	
Response Time		Total ($T_r + T_d$)	Ta= 25°C $\Theta = 0^\circ$	-	30	-	ms	Note 5
Cross Talk		CT	$\Theta = 0^\circ$	-	-	2.0	%	Note 6



HYDIS

PRODUCT GROUP	REV	ISSUE DATE
TFT LCD PRODUCT	0	2010. 10.21

Note : 1. Viewing angle is the angle at which the contrast ratio is greater than 10. The viewing are determined for the horizontal or 3, 9 o'clock direction and the vertical or 6, 12 o'clock direction with respect to the optical axis which is normal to the LCD surface (see FIGURE 1 shown in page 11).

2. Contrast measurements shall be made at viewing angle of $\Theta = 0^\circ$ and at the center of the LCD surface. Luminance shall be measured with all pixels in the view field set first to white, then to the dark (black) state. (See FIGURE 1 shown in page 11)
Luminance Contrast Ratio (CR) is defined mathematically.

$$CR = \frac{\text{Luminance when displaying a white raster}}{\text{Luminance when displaying a black raster}}$$

3. The White luminance uniformity on LCD surface is then expressed.
(See FIGURE 2~3 shown in page 12)

$$\text{Uniformity } \Delta Y = \frac{\text{Minimum Luminance of 5(or 13) points}}{\text{Maximum Luminance of 5(or 13) points}} \times 100 (\%)$$

4. The color chromaticity coordinates specified in Table 4 shall be calculated from the spectral data measured with all pixels first in red, green, blue and white. Measurements shall be made at the center of the panel.
5. The electro-optical response time measurements shall be made as FIGURE 4 shown in page 13 by switching the "data" input signal OFF and ON. The times needed for the luminance to change from 10% to 90% is T_r , and 90% to 10% is T_d . (See FIGURE 4 shown in page 13)
6. Cross-Talk of one area of the LCD surface by another shall be measured by comparing the luminance (YA) of a 25mm diameter area, with all display pixels set to a gray level, to the luminance (YB) of that same area when any adjacent area is driven dark. (See FIGURE 5 shown in page 13)

SPEC. NUMBER S864-1419	SPEC TITLE HX121WX1-111 Product Specification	PAGE 10 OF 34
---------------------------	--	------------------

4.3 Optical Measurements

Figure 1. Measurement Set Up

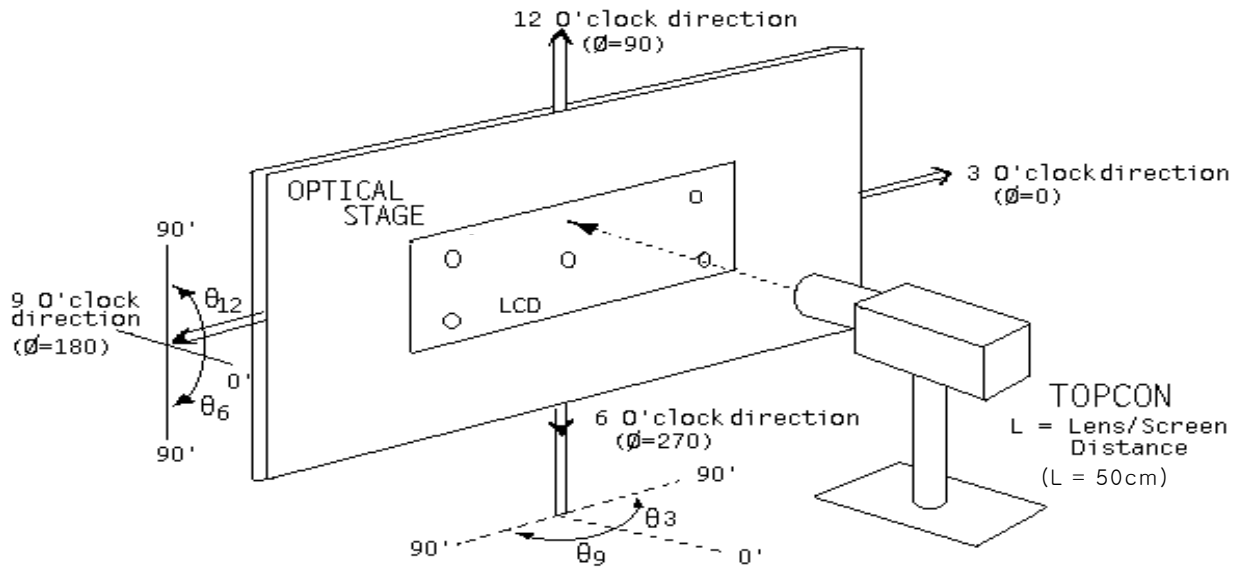

< Indoor >

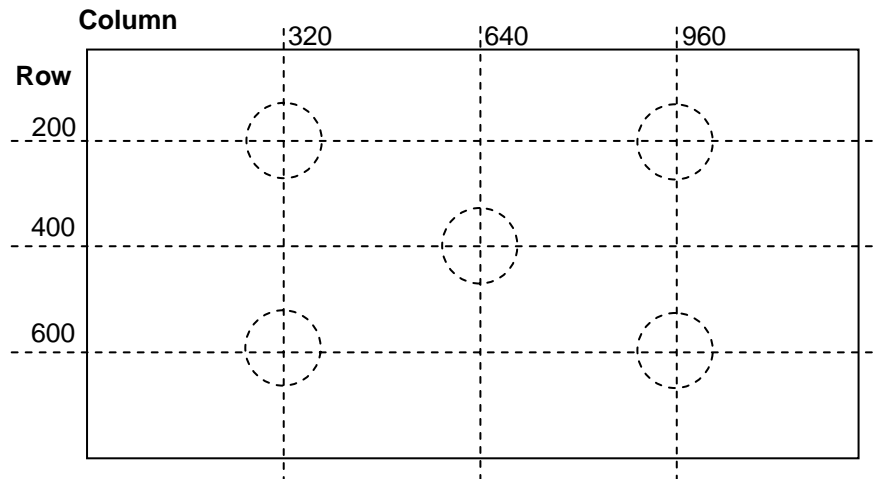
Figure 2. White Luminance and Uniformity Measurement Locations (5 points)

Note.

Luminance of white is defined as luminance values of 5 points across the LCD surface. Luminance shall be measured with all pixels in the view field set first to white. This measurement shall be taken at the locations shown in Figure 2 for a total of the measurements per display.

$$* Y_w = (\text{Sum of 5 Points Luminance} / 5)$$

Figure 3. Uniformity Measurement Locations (13 points)

Figure 4. Response Time Testing

Figure 5. Cross Modulation Test Description

$$\text{Cross-Talk (\%)} = \left| \frac{Y_B - Y_A}{Y_B} \right| \times 100$$

Where:

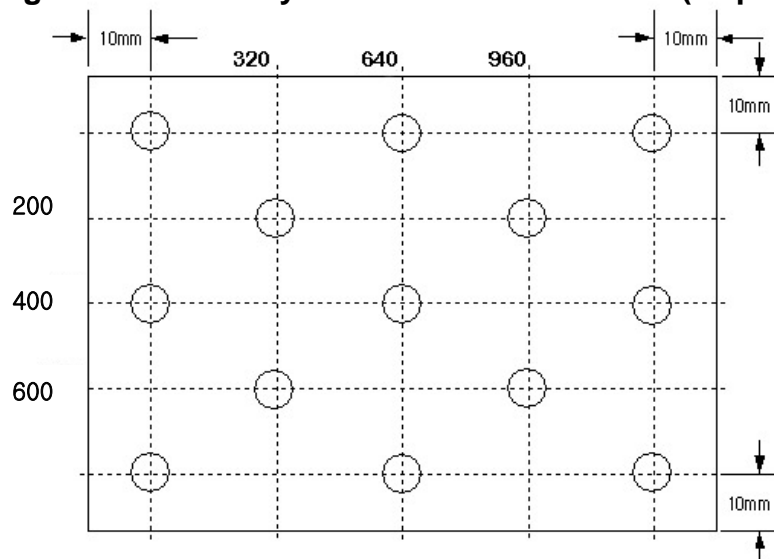
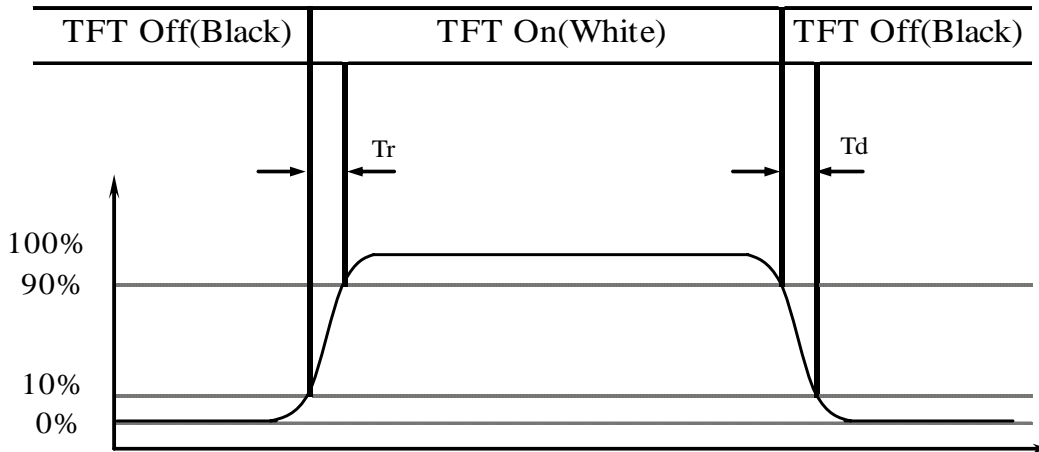
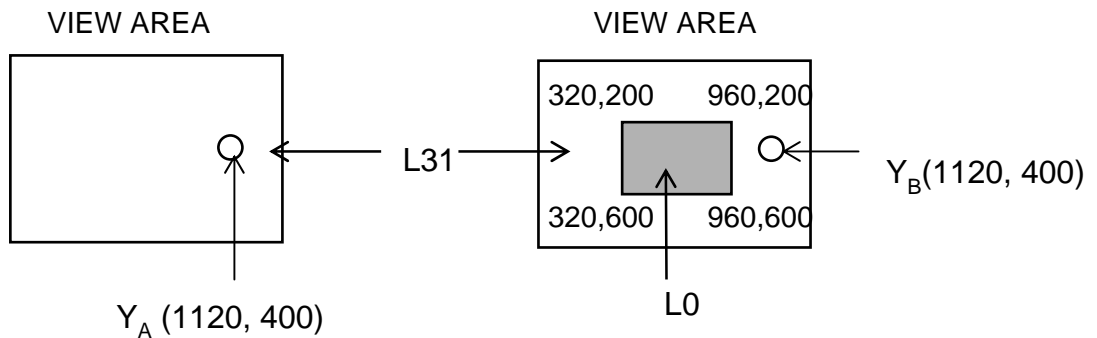
Y_A = Initial luminance of measured area (cd/m^2)

Y_B = Subsequent luminance of measured area (cd/m^2)

The location measured will be exactly the same in both patterns

5.0 INTERFACE CONNECTIONS

5.1 Electrical Interface Connection

CN1 Interface Connector (FI-JT40S-HF10, Manufactured by JAE)

Pin No.	Symbol	Function	Pin No.	Symbol	Function
1	GND1	GROUND	21	GND6	GROUND
2	CONNTST	Connector Test	22	RCLKIN-	LVDS Negative clock signal (-)
3	LVDD1	Logic Power Supply : +3.3V	23	RCLKIN+	LVDS Positive clock signal (+)
4	LVDD2	Logic Power Supply : +3.3V	24	GND7	GROUND
5	LVDD3	Logic Power Supply : +3.3V	25	VDIM	PWM Brightness Control
6	VDD_DEID	EDID Power Supply : +3.3V	26	BL ON	B/L ON/OFF
7	TEST	NON-CONNECTION	27	Reserved	NON-CONNECTION
8	CLK_EDID	EDID Clock	28	HVGND1	GROUND
9	DATA_EDID	EDID Data	29	HVGND2	GROUND
10	GND2	GROUND	30	HVGND3	GROUND
11	GND3	GROUND	31	HVGND4	GROUND
12	NC	NON-CONNECTION	32	HVGND5	GROUND
13	RIN0-	LVDS Negative data signal (-)	33	NC	NON-CONNECTION
14	RIN0+	LVDS Positive data signal (+)	34	HVDD1	Back-light Power Supply: +12V
15	GND4	GROUND	35	HVDD2	Back-light Power Supply: +12V
16	RIN1-	LVDS Negative data signal (-)	36	HVDD3	Back-light Power Supply: +12V
17	RIN1+	LVDS Positive data signal (+)	37	HVDD4	Back-light Power Supply: +12V
18	GND5	GROUND	38	HVDD5	Back-light Power Supply: +12V
19	RIN2-	LVDS Negative data signal (-)	39	CONNTST	Connector Test
20	RIN2+	LVDS Positive data signal (+)	40	GND8	GROUND

Note 1. Connected with No. 2 & 39

Note 2. Start from left side

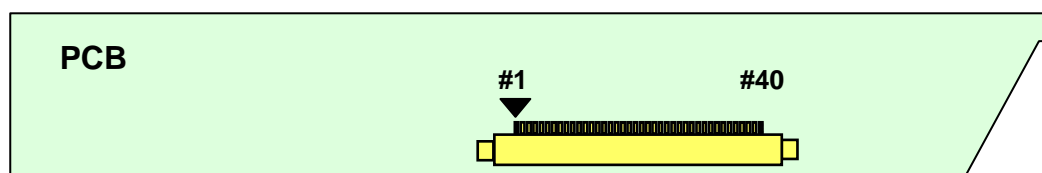

CN1 (FI-JT40S-HF10)

SPEC. NUMBER
S864-1419

SPEC TITLE
HX121WX1-111 Product Specification

PAGE
14 OF 34



PRODUCT GROUP

REV

ISSUE DATE

TFT LCD PRODUCT

0

2010. 10.21

5.2 LVDS Interface

LVDS Transmitter : THC63LVDM83A

Input signal	Transmitter		Interface		FI-JH40S-HF10	Remark
	Pin No	Pin No	System (Tx)	TFT-LCD (Rx)	Pin No.	
R0	51	48 47	OUT0- OUT0+	IN0- IN0+	13 14	
R1	52					
R2	54					
R3	55					
R4	56					
R5	3					
G0	4					
G1	6	46 45	OUT1- OUT1+	IN1- IN1+	16 17	
G2	7					
G3	11					
G4	12					
G5	14					
B0	15					
B1	19					
B2	20	42 41	OUT2- OUT2+	IN2- IN2+	19 20	
B3	22					
B4	23					
B5	24					
HSYNC	27					
VSYNC	28					
DE	30					
MCLK	31	40	CLKOUT-	CLKIN-	22	
		39	CLKOUT+	CLKIN+	23	

SPEC. NUMBER
S864-1419

SPEC TITLE
HX121WX1-111 Product Specification

PAGE
15 OF 34

5.3 Back-light Interface

CN2 LED FPC Connector (04-6298-009, Manufactured by Kyocera)

Pin No.	Symbol	Function	Remark
1	Anode1	LED Anode Power Supply	LED Anode Power Supply (3.25V X 12EA = 39V)
2	Anode2	LED Anode Power Supply	
3	Anode3	LED Anode Power Supply	
4	Anode4	LED Anode Power Supply	
5	NC	Non-Connection	
6	Cathode1	LED Cathode Power Supply	LED Cathode Power Supply
7	Cathode2	LED Cathode Power Supply	
8	Cathode3	LED Cathode Power Supply	
9	Cathode4	LED Cathode Power Supply	

5.4 Data Input Format

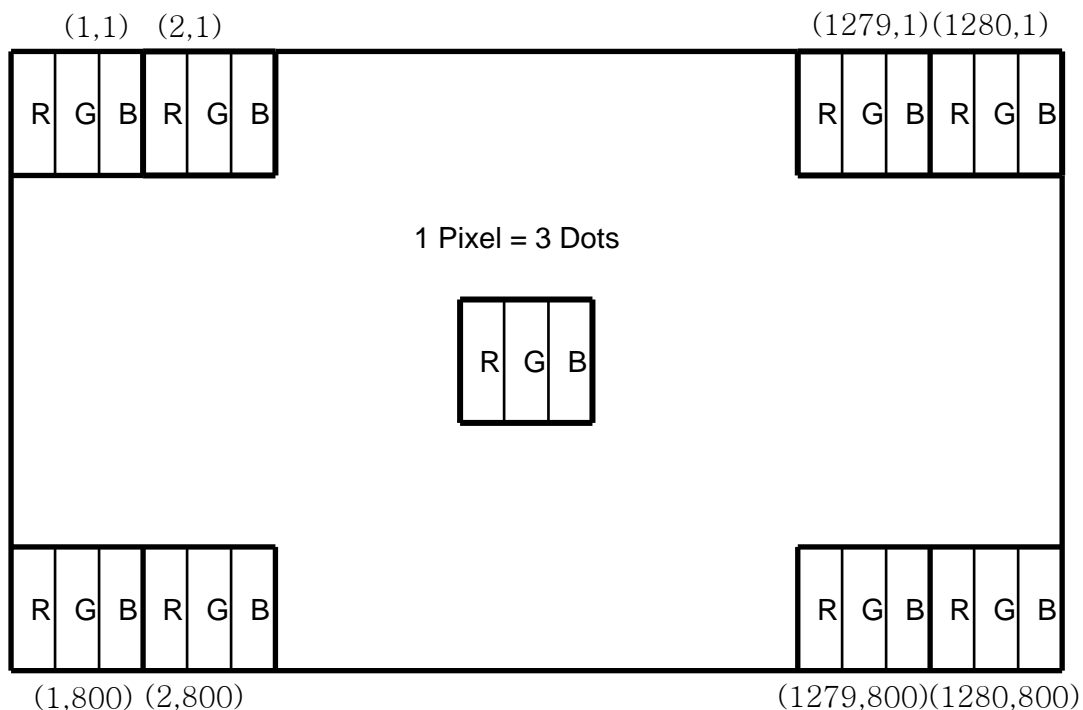

6.0. SIGNAL TIMING SPECIFICATIONS

6.1 The 12.1" WXGA LCM is operated by the only DE (Data enable) mode (LVDS Transmitter Input)

Item	Symbol	Min.	Typ.	Max.	Unit
Frame Period	T1	-	823	-	Lines
Vertical Display Period	T2	-	800	-	Lines
One line Scanning Period	T3	-	1522	-	Clocks
Horizontal Display Period	T4	-	1280	-	Clocks
Clock Frequency	1/T5	-	75.16	-	MHz

7.0 SIGNAL TIMING WAVEFORMS

7.1 Timing Waveforms of Interface Signal

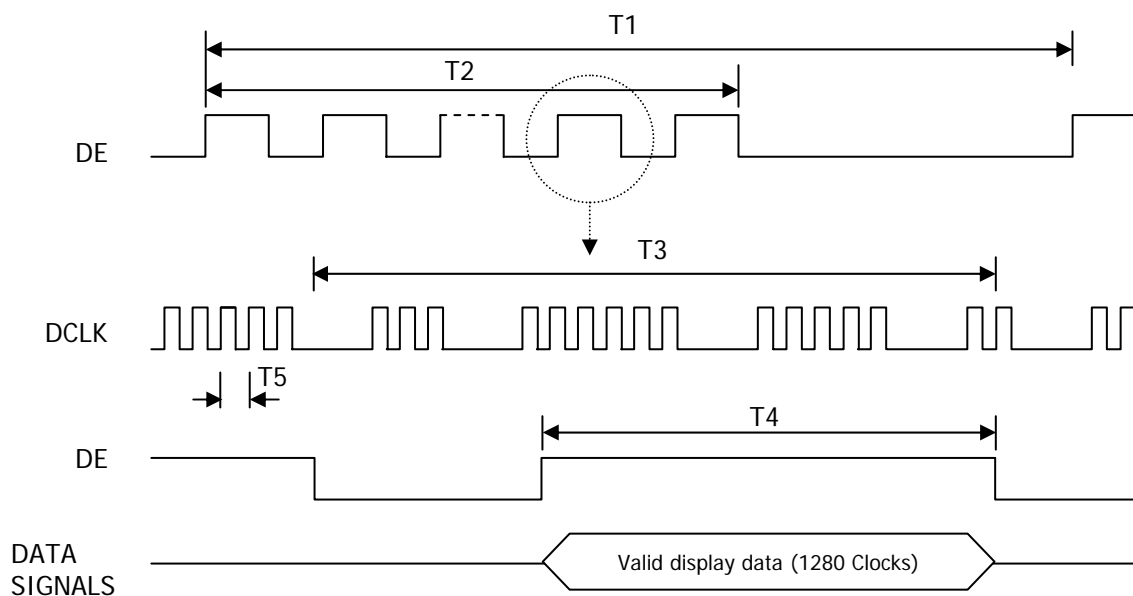

7.2 LVDS Rx Interface Timing Parameter

The specification of the LVDS Rx interface timing parameter

< LVDS Rx Interface Timing Specification >

Item	Symbol	Min.	Typ.	Max.	Unit	Remarks
CLKIN Period	tRCIP	12.50	14.06	25.00	nsec	
Input Data 0	tRIP0	-0.4	0.0	+0.4	nsec	
Input Data 1	tRIP1	tRCIP/7-0.4	tRCIP/7	tRCIP/7+0.4	nsec	
Input Data 2	tRIP2	2 × tRCIP/7-0.4	2 × tRCIP/7	2 × tRCIP/7+0.4	nsec	
Input Data 3	tRIP3	3 × tRCIP/7-0.4	3 × tRCIP/7	3 × tRCIP/7+0.4	nsec	
Input Data 4	tRIP4	4 × tRCIP/7-0.4	4 × tRCIP/7	4 × tRCIP/7+0.4	nsec	
Input Data 5	tRIP5	5 × tRCIP/7-0.4	5 × tRCIP/7	5 × tRCIP/7+0.4	nsec	
Input Data 6	tRIP6	6 × tRCIP/7-0.4	6 × tRCIP/7	6 × tRCIP/7+0.4	nsec	

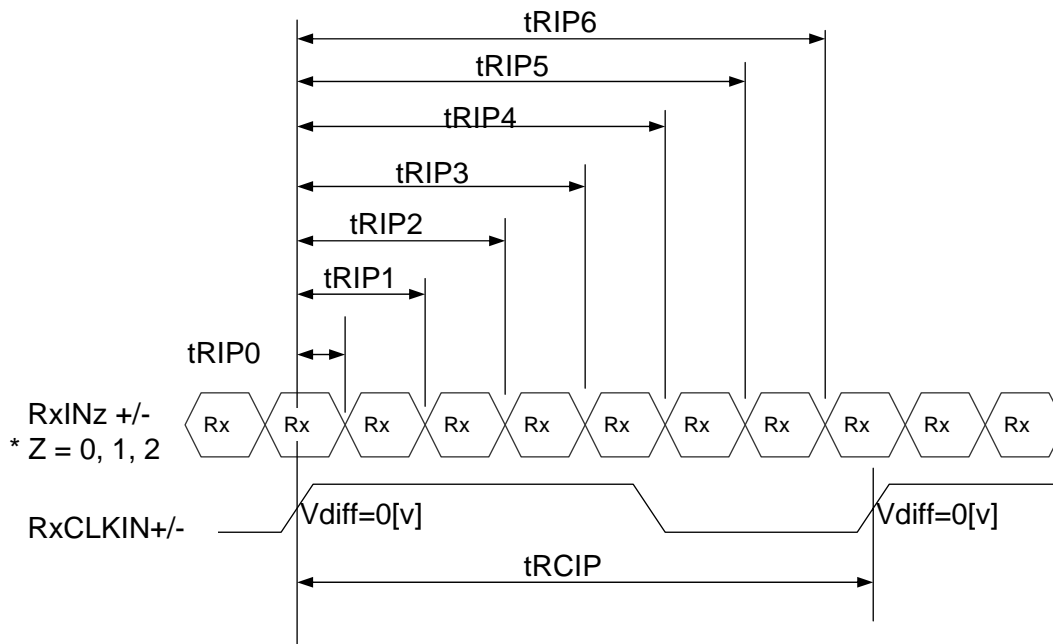



PRODUCT GROUP

REV

ISSUE DATE

TFT LCD PRODUCT

0

2010. 10.21

8.0 INPUT SIGNALS, BASIC DISPLAY COLORS & GRAY SCALE OF COLORS

Each color is displayed in sixty-four gray scales from a 6 bit data signal input. A total of 262,144 colors are derived from the resultant 18 bit data.

Colors & Gray Scale		Red Data						Green Data						Blue Data					
		R5	R4	R3	R2	R1	R0	G5	G4	G3	G2	G1	G0	B5	B4	B3	B2	B1	B0
Basic Colors	Black	0	0	0	0	0	0	0	0	0	0	0	0	0	0	0	0	0	0
	Blue	0	0	0	0	0	0	0	0	0	0	0	0	1	1	1	1	1	1
	Green	0	0	0	0	0	0	1	1	1	1	1	1	0	0	0	0	0	0
	Cyan	0	0	0	0	0	0	1	1	1	1	1	1	1	1	1	1	1	1
	Red	1	1	1	1	1	1	0	0	0	0	0	0	0	0	0	0	0	0
	Magenta	1	1	1	1	1	1	0	0	0	0	0	0	1	1	1	1	1	1
	Yellow	1	1	1	1	1	1	1	1	1	1	1	1	0	0	0	0	0	0
	White	1	1	1	1	1	1	1	1	1	1	1	1	1	1	1	1	1	1
Gray Scale Of Red	Black	0	0	0	0	0	0	0	0	0	0	0	0	0	0	0	0	0	0
	△	0	0	0	0	0	1	0	0	0	0	0	0	0	0	0	0	0	0
	Darker	0	0	0	0	1	0	0	0	0	0	0	0	0	0	0	0	0	0
	△	↓						↓						↓					
	▽	↓						↓						↓					
	Brighter	1	1	1	1	0	1	0	0	0	0	0	0	0	0	0	0	0	0
	▽	1	1	1	1	1	0	0	0	0	0	0	0	0	0	0	0	0	0
	Red	1	1	1	1	1	1	0	0	0	0	0	0	0	0	0	0	0	0
Gray Scale Of Green	Black	0	0	0	0	0	0	0	0	0	0	0	0	0	0	0	0	0	0
	△	0	0	0	0	0	0	0	0	0	0	0	1	0	0	0	0	0	0
	Darker	0	0	0	0	0	0	0	0	0	0	1	0	0	0	0	0	0	0
	△	↓						↓						↓					
	▽	↓						↓						↓					
	Brighter	0	0	0	0	0	0	1	1	1	1	0	1	0	0	0	0	0	0
	▽	0	0	0	0	0	0	1	1	1	1	1	0	0	0	0	0	0	0
	Green	0	0	0	0	0	0	1	1	1	1	1	1	0	0	0	0	0	0
Gray Scale Of Blue	Black	0	0	0	0	0	0	0	0	0	0	0	0	0	0	0	0	0	0
	△	0	0	0	0	0	0	0	0	0	0	0	0	0	0	0	0	0	1
	Darker	0	0	0	0	0	0	0	0	0	0	0	0	0	0	0	0	1	0
	△	↓						↓						↓					
	▽	↓						↓						↓					
	Brighter	0	0	0	0	0	0	0	0	0	0	0	0	1	1	1	1	0	1
	▽	0	0	0	0	0	0	0	0	0	0	0	0	1	1	1	1	1	0
	Blue	0	0	0	0	0	0	0	0	0	0	0	0	1	1	1	1	1	1
Gray Scale Of White & Black	Black	0	0	0	0	0	0	0	0	0	0	0	0	0	0	0	0	0	0
	△	0	0	0	0	0	1	0	0	0	0	0	1	0	0	0	0	0	1
	Darker	0	0	0	0	1	0	0	0	0	0	1	0	0	0	0	0	1	0
	△	↓						↓						↓					
	▽	↓						↓						↓					
	Brighter	1	1	1	1	0	1	1	1	1	1	0	1	1	1	1	1	0	1
	▽	1	1	1	1	1	0	1	1	1	1	1	0	1	1	1	1	1	0
	White	1	1	1	1	1	1	1	1	1	1	1	1	1	1	1	1	1	1

SPEC. NUMBER
S864-1419

SPEC TITLE
HX121WX1-111 Product Specification

PAGE
19 OF 34

9.0 SEQUENCE

To prevent a latch-up or DC operation of the LCD module, the power on/off sequence shall be as shown in below

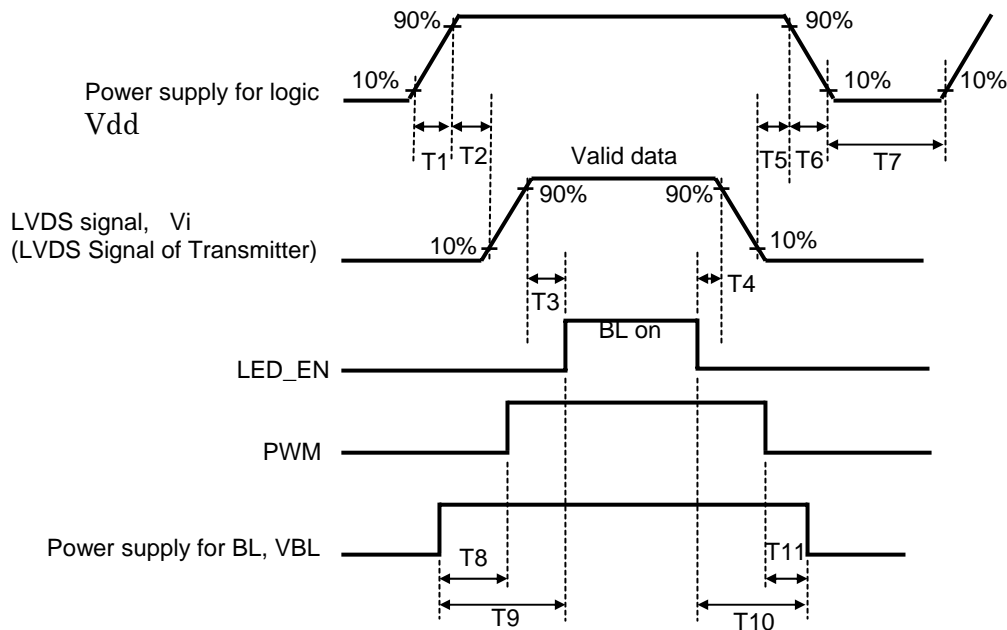

ITEMS	Unit	Min.	Typ.	Max.
T1	ms	0	-	10
T2	ms	0	-	50
T3	ms	200	-	-
T4	ms	0	-	-
T5	ms	0	-	-
T6	ms	0	-	10
T7	ms	150	-	-
T8 (Only Internal controller)	ms	0	-	-
T9 (Only Internal controller)	ms	0	-	-
T10 (Only Internal controller)	ms	0	-	-
T11 (Only Internal controller)	ms	0	-	-

- Notes :
1. When the power supply VDD is 0V, Keep the level of input signals on the low or keep high impedance.
 2. Do not keep the interface signal high impedance when power is on.
 3. Back Light must be turn on after power for logic and interface signal are valid.
 4. VDD and VBL circuit should be independent.

10.0 MECHANICAL CHARACTERISTICS

10.1 Dimensional Requirements

Figure 6 & 7 (located in 11.0) shows mechanical outlines for the model

Parameter	Specification	Unit
Active Area	261.12(H) X 163.20(V)	mm
Number of pixels	1280(H) X 800(V) (1 pixel = R + G + B dots)	
Pixel pitch	0.204(H) X 0.204(V)	
Pixel arrangement	RGB Vertical stripe	
Display colors	262,144	
Display mode	Normally Black	
Outline dimension	276.8±0.3(H)×180.0(V)±0.3×6.8(D:Max.)	mm
Weight	265(Typ.) / 275(Max.)	g
Back-light	SMD LED (48EA) Array	

10.2 Mounting

See Figure 6 & 7 & 8. (shown in 11.0)

Parameter	Specification	Unit
Torque of side mounting screw	3.0(Max.)	kgf
Torque of ground plate screw	1.5(Max.)	kgf

10.3 Anti-Glare and Polarizer Hardness.

The surface of the LCD has an anti-glare coating to minimize reflection and a coating to reduce scratching.

10.4 Light Leakage

There shall not be visible light from the back-lighting system around the edges of the screen as seen from a distance 50cm from the screen with an overhead light level of 150lux. The manufacture shall furnish limit samples of the panel showing the light leakage acceptable.

11.0 Mechanical Drawing

Figure 6. TFT-LCD Module Outline Dimension (Front View)

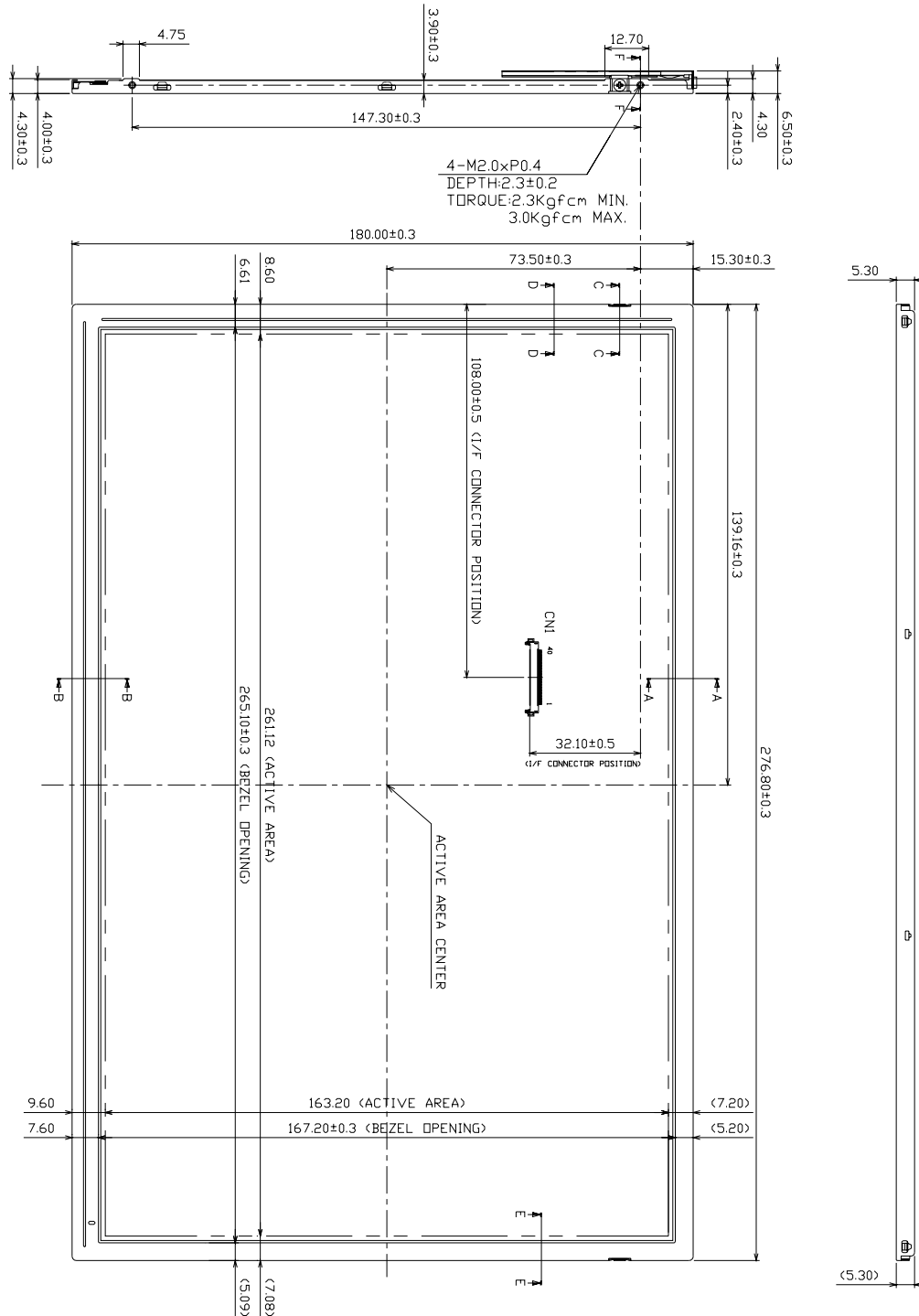
 SPEC. NUMBER
 S864-1419

 SPEC TITLE
 HX121WX1-111 Product Specification

 PAGE
 22 OF 34

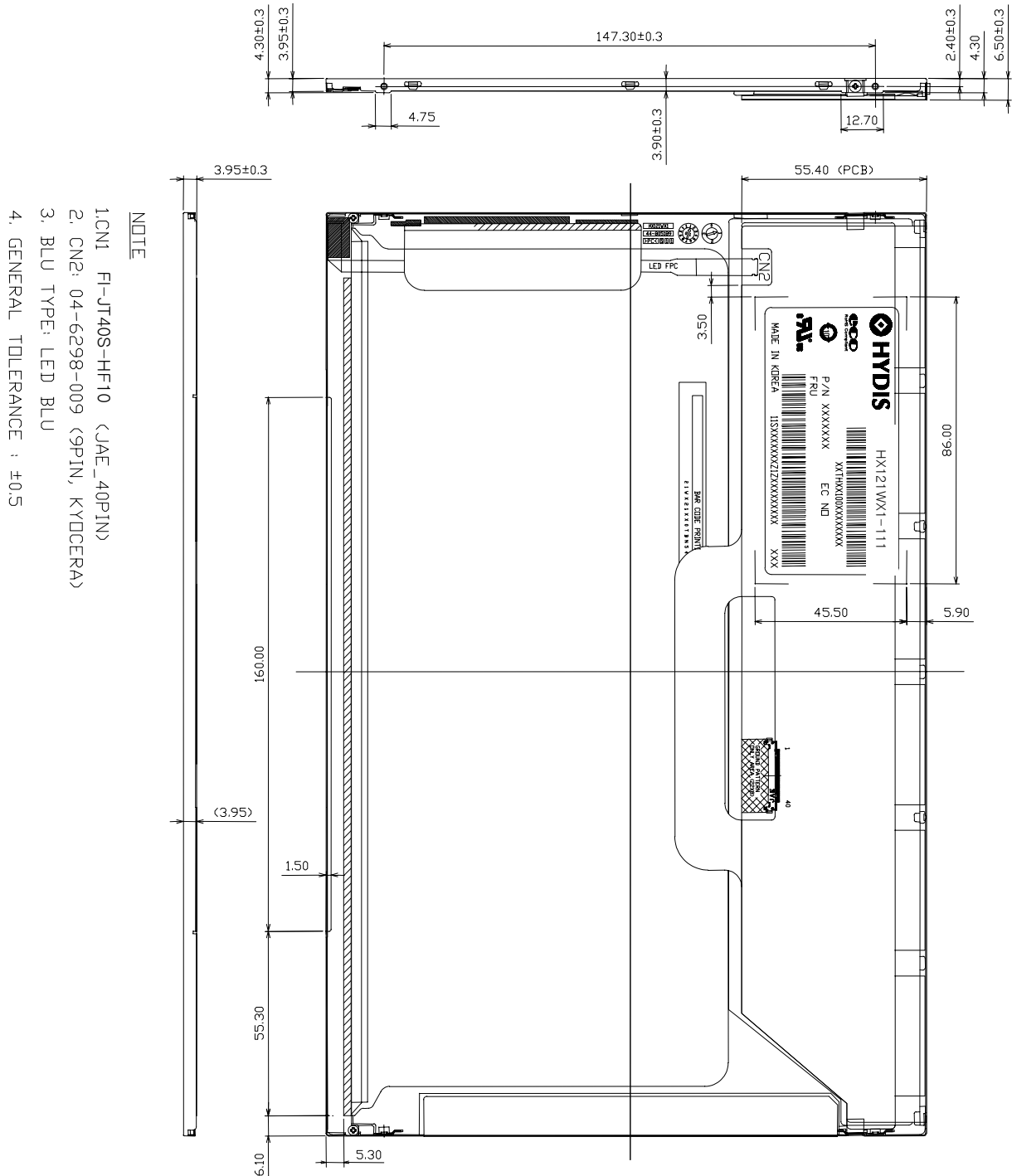
Figure 7. TFT-LCD Module Outline Dimensions (Rear view)

 SPEC. NUMBER
 S864-1419

 SPEC TITLE
 HX121WX1-111 Product Specification

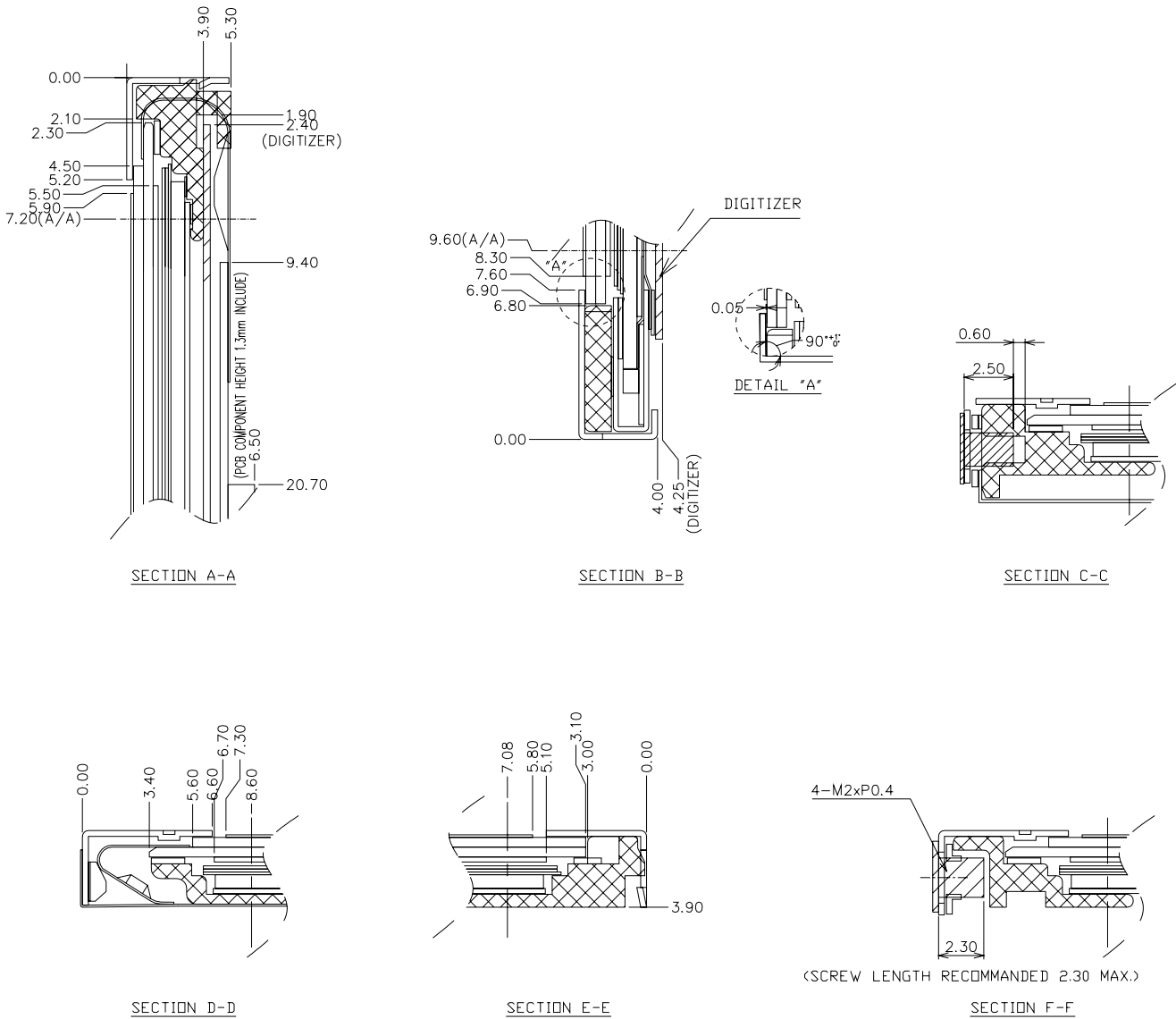
 PAGE
 23 OF 34

Figure 8. TFT-LCD Module Section for Main Position

12.0 RELIABILITY TEST

The Reliability test items and its conditions are shown in below.

<Table 12. Reliability Test>

No	Test Item	Conditions
1	High temperature storage test	Ta = 60 °C, 240 hrs
2	Low temperature storage test	Ta = -20 °C, 240 hrs
3	High temperature & high humidity operation test	Ta = 50 °C, 80%RH, 240hrs
4	High temperature operation test	Ta = 50 °C, 240 hrs
5	Low temperature operation test	Ta = 0 °C, 240 hrs
6	Thermal shock	Ta = -20 °C ↔ 60 °C (30 min), 100 cycle
7	Vibration test (non-operating)	Frequency : 10~500Hz Gravity/AMP : 1.5G Period : X,Y,Z 30min
8	Shock test (non-operating)	Gravity : 220G Pulse width : 2ms, half sine wave ±X, ±Y, ±Z Once for each direction
9	Electro-static discharge test (non-operating)	Air : 150pF, 330ohm, 15KV Contact : 150pF, 330ohm, 8KV

13.0 HANDLING & CAUTIONS

13.1 Cautions when taking out the module

- Pick the pouch only, when taking out module from a shipping package.

13.2 Cautions for handling the module

- As the electrostatic discharges may break the LCD module, handle the LCD module with care. Peel a protection sheet off from the LCD panel surface as slowly as possible.
- As the LCD panel and back - light element are made from fragile glass (epoxy) material, impulse and pressure to the LCD module should be avoided.
- As the surface of the polarizer is very soft and easily scratched, use a soft dry cloth without chemicals for cleaning.
- Do not pull the interface connector in or out while the LCD module is operating.
- Put the module display side down on a flat horizontal plane.
- Handle connectors and cables with care.



PRODUCT GROUP

REV

ISSUE DATE

TFT LCD PRODUCT

0

2010. 10.21

13.3 Cautions for the operation

- When the module is operating, do not lose MCLK, DE signals. If any one of these signals were lost, the LCD panel would be damaged.
- Obey the supply voltage sequence. If wrong sequence is applied, the module would be damaged.

13.4 Cautions for the atmosphere

- Dew drop atmosphere should be avoided.
- Do not store and/or operate the LCD module in a high temperature and/or humidity atmosphere. Storage in an electro-conductive polymer packing pouch and under relatively low temperature atmosphere is recommended.

13.5 Cautions for the module characteristics

- Do not apply fixed pattern data signal to the LCD module at product aging.
- Applying fixed pattern for a long time may cause image sticking.

13.6 Cautions for the digitizer assembly

- When assembling FPC connector, do not flip connector past 90° due to possible damage to connector.
- When positioning digitizer underneath driver IC, do not lift driver IC past 90° due to possible damage to drive IC pattern.
- Please be warned that during assembly of digitizer, the opening or closing of FPC will result in possible electrostatic discharge damage to the LED

13.7 Other cautions

- Do not re-adjust variable resistor or switch etc.
- When returning the module for repair or etc., Please pack the module not to be broken. We recommend to use the original shipping packages.

SPEC. NUMBER
S864-1419

SPEC TITLE
HX121WX1-111 Product Specification

PAGE
26 OF 34



PRODUCT GROUP	REV	ISSUE DATE
TFT LCD PRODUCT	0	2010. 10.21

14.0 LABELS

14.1 Product Label



HYDIS Barcode

1	2	3	4	5	6	7
X	X	X	X X X	1	0 0 X X	X X X X X X

Type designation

- No 1. Control Number
- No 2. Rank / Grade
- No 3. Company (H : HYDIS)
- No 4. Year (9 : 2009,...)
- No 5. Month (1, 2, 3, ..., 9, X, Y, Z)
- No 6. Product Identification (FG)
- No 7. Serial Number

Lenovo Barcode

1	2	3	4	5	6	7
1 1 S	X X X X X X X	Z	1 Z	X X X	X X X X X X	y m m

Type designation

- No 1. Barcode Fromat ID "11S"
- No 2. Part Number
- No 3. Indicator (Shuld "Z")
- No 4. Yamato Control ID " 1Z"
- No 5. Code Header
- No 6. Serial Number
- No 7. Manufacturing Date Code
y : year lower 1-digit
mm : month (01-12)

SPEC. NUMBER S864-1419	SPEC TITLE HX121WX1-111 Product Specification	PAGE 27 OF 34
---------------------------	--	------------------



PRODUCT GROUP

REV

ISSUE DATE

TFT LCD PRODUCT

0

2010. 10.21

14.2 Packing Label

Label Size: 108 mm (L) × 56 mm (W)

Contents

Model: HX121WX1-111

Q`ty: Module Q`ty in one box

Serial No.: Box Serial No. See next figure for detail description.

Date: Packing Date

FG Code: FG Code of Product

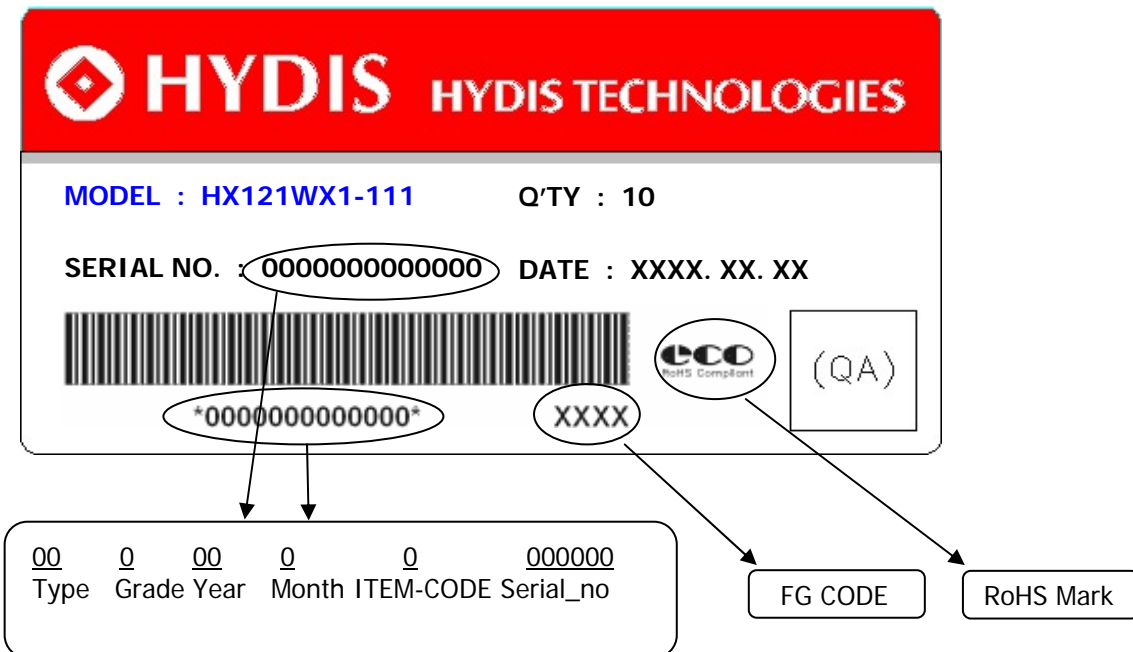

SPEC. NUMBER

S864-1419

SPEC TITLE

HX121WX1-111 Product Specification

PAGE

28 OF 34

15.0 PACKING INFORMATION

15.1 Packing order

Put Pad into the box.

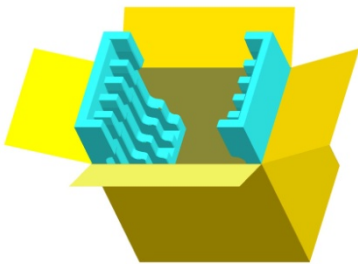

Put silica gels in the box.

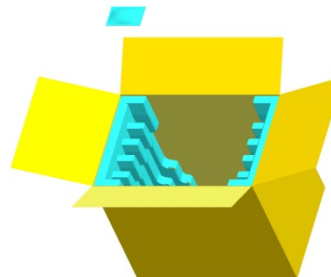

After sealing the box, attach Packing Label on the attach position sign area of the box.

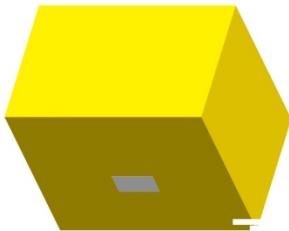

Place a cover on the top of the box.

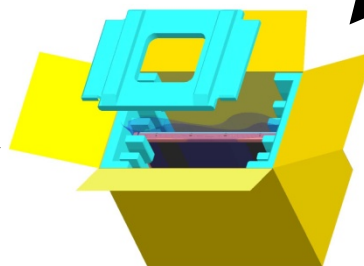

As shown in the figure, place the Modules bundled by shielding bag in the box.

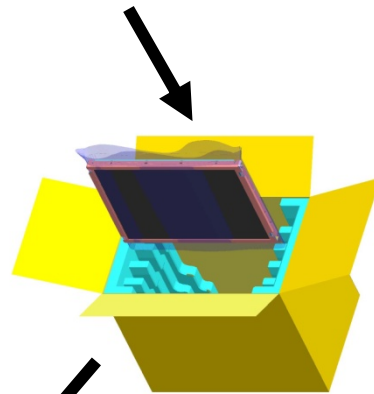

15.2 Notes

- Box Dimension : 349.0mm(W) X 261.0mm(D) X 311.0mm(H)
- Package Quantity in one Box : 10pcs

15.3 Pallet Packing

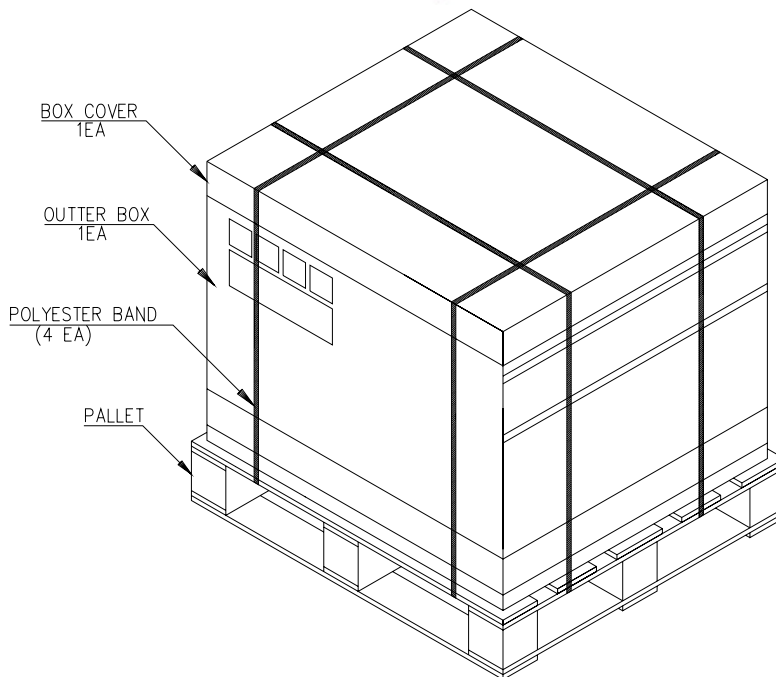
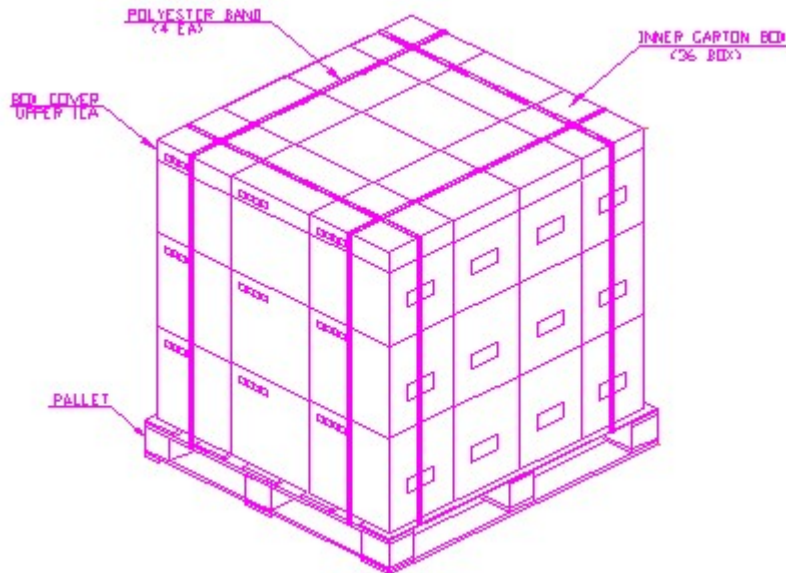

Notes

- Pallet Dimension : : 1100 mm (L) × 1100 mm (W) × 120 mm (H)
- Package Quantity in one Box : 10pcs
- Box Quantity in one Pallet : 36ea



PRODUCT GROUP

REV

ISSUE DATE

TFT LCD PRODUCT

0

2010. 10.21

16.0 EDID Data

Address	Field Name and Comments	Value	Remark
00	Header	00	
01	Header	FF	
02	Header	FF	
03	Header	FF	
04	Header	FF	
05	Header	FF	
06	Header	FF	
07	Header	00	
08	ID Manufacturer Name	30	LEN
09		AE	
0A	ID Product Code	11	12" 16:10 WXGA 1280x800 LED B/L
0B		40	
0C	ID Serial Number (32-bit serial number)	00	# 0
0D		00	
0E		00	
0F		00	
10	Week of Manufacture	00	0 weeks
11	Year of Manufacture	12	2008 years
12	EDID Structure version	01	Ver. 1.3
13	EDID Revision	03	
14	Video Input Definition	80	Digital
15	Max H Image Size(cm)	1A	26cm
16	Max V Image Size(cm)	10	16cm
17	Display gamma (gamma x 100)-100	78	2.20
18	Feature support(DPMS)	EA	Standby , Suspend , Active Off/Very Low Power ,RGB color display , Preferred Timing Mode
19	Red/Green Low Bits	E7	
1A	Blue/White Low Bits	95	
1B	Red x	93	0.577
1C	Red y	5E	0.369
1D	Green x	59	0.349
1E	Green y	91	0.569
1F	Blue x	26	0.150
20	Blue y	1F	0.122
21	White x	50	0.313
22	White y	54	0.329

SPEC. NUMBER
S864-1419

SPEC TITLE
HX121WX1-111 Product Specification

PAGE
31 OF 34



PRODUCT GROUP

REV

ISSUE DATE

TFT LCD PRODUCT

0

2010. 10.21

Address	Field Name and Comments	Value	Remark
23	Established Timing 1	00	
24	Established Timing 2	00	
25	Manufacturer's Timings	00	
26	Standard Timing Identification #1	01	
27		01	
28	Standard Timing Identification #2	01	
29		01	
2A	Standard Timing Identification #3	01	
2B		01	
2C	Standard Timing Identification #4	01	
2D		01	
2E	Standard Timing Identification #5	01	
2F		01	
30	Standard Timing Identification #6	01	
31		01	
32	Standard Timing Identification #7	01	
33		01	
34	Standard Timing Identification #8	01	
35		01	
36	Pixel Clock/10,000 (LSB)	5C	75.16MHz (Refresh rate 60 Hz)
37	Pixel Clock/10,000 (MSB) /	1D	
38	Horizontal Active	00	1280 pixels
39	Horizontal Blanking	F2	242 pixels
3A	Horizontal Active : Horizontal Blanking	50	
3B	Vertical Active	20	800 lines
3C	Vertical Blanking	17	23 lines
3D	Vertical Active : Vertical Blanking	30	
3E	Horizontal Sync. Offset	30	48 pixels
3F	Horizontal Sync Pulse Width	54	84 pixels
40	Vertical Sync Offset : Sync Width	36	3 lines / 6 lines
41	Horizontal Vertical Sync Offset/Width upper 2bits	00	
42	Horizontal Image Size	05	261 mm
43	Vertical Image Size	A3	163 mm
44	Horizontal & Vertical Image Size	10	
45	Horizontal Border	00	0 pixels
46	Vertical Border	00	0 lines
47	Flags	19	Non-interlaced , Normal display, no stereo , Digital separate , Vertical Polarity Negative , Horizontal Polarity Negative

SPEC. NUMBER
S864-1419

SPEC TITLE
HX121WX1-111 Product Specification

PAGE
32 OF 34



PRODUCT GROUP

REV

ISSUE DATE

TFT LCD PRODUCT

0

2010. 10.21

Address	Field Name and Comments	Value	Remark
48	Pixel Clock/10,000 (LSB) (Slow Refresh rate)	5C	75.16MHz (Refresh rate 60 Hz)
49	Pixel Clock/10,000 (MSB) (Slow Refresh rate)	1D	
4A	Horizontal Active	00	1280 pixels
4B	Horizontal Blanking	F2	242 pixels
4C	Horizontal Active : Horizontal Blanking	50	
4D	Vertical Active	20	800 lines
4E	Vertical Blanking	17	23 lines
4F	Vertical Active : Vertical Blanking	30	
50	Horizontal Sync. Offset	30	48 pixels
51	Horizontal Sync Pulse Width	54	84 pixels
52	Vertical Sync Offset : Sync Width	36	3 lines / 6 lines
53	Horizontal Vertical Sync Offset/Width upper 2bits = 0	00	
54	Horizontal Image Size	05	261 mm
55	Vertical Image Size	A3	163 mm
56	Horizontal & Vertical Image Size	10	
57	Horizontal Border	00	0 pixels
58	Vertical Border	00	0 lines
59	Flags	19	Non-interlaced , Normal display, no stereo , Digital separate , Vertical Polarity Negative , Horizontal Polarity Negative
5A	Flag	00	
5B	Flag	00	
5C	Flag	00	
5D	Data Type Tag	0F	Description defined by manufacture
5E	Flag	00	
5F	(Horizontal active pixel /8)-31	81	1280 pixel
60	Image Aspect Ratio	0A	16 : 10
61	Middle Refresh Rate	3C	60 Hz
62	(Horizontal active pixel /8)-31	81	1280 pixel
63	Image Aspect Ratio	0A	16 : 10
64	Low Refresh Rate	3C	60 Hz
65	Brightness(1/10nit)	14	200 nit
66	Feature flag	0A	IPS/FFS/VA LED Backlight
67	Reserved	00	
68	LCD Supplier manufacture Code (3 character ID)	00	#N/A
69		00	
6A	LCD Supplier Product code	9E	
6B	LCD Supplier Product code	08	

SPEC. NUMBER
S864-1419

SPEC TITLE
HX121WX1-111 Product Specification

PAGE
33 OF 34



HYDIS

PRODUCT GROUP

REV

ISSUE DATE

TFT LCD PRODUCT

0

2010. 10.21

Address	Field Name and Comments	Value	Remark
6C	Flag	00	
6D	Flag	00	
6E	Flag	00	
6F	Data Type Tag	FE	ASCII String
70	Flag	00	
71	Model Name	48	H
72	Model Name	58	X
73	Model Name	31	1
74	Model Name	32	2
75	Model Name	31	1
76	Model Name	57	W
77	Model Name	58	X
78	Model Name	31	1
79	Model Name	2D	-
7A	Model Name	31	1
7B	Model Name	31	1
7C	Model Name	31	1
7D	Model Name	0A	^
7E	Extension flag	00	
7F	Checksum	CE	

SPEC. NUMBER
S864-1419

SPEC TITLE
HX121WX1-111 Product Specification

PAGE
34 OF 34