



**HYDIS**

**PROPRIETARY NOTE**

THIS SPECIFICATION IS THE PROPERTY OF HYDIS AND SHALL NOT BE REPRODUCED OR COPIED WITHOUT THE WRITTEN PERMISSION OF HYDIS AND MUST BE RETURNED TO HYDIS UPON ITS REQUEST

**TITLE : HX121WX1-121**  
**Product Specification**

**HYDIS Technologies**

SPEC. NUMBER	PRODUCT GROUP	REV.	ISSUE DATE	PAGE
S864-1429	TFT LCD	0	2010.12.15	1 OF 33



## Contents

No	Item	Page
1.0	General Description	4
2.0	Absolute Maximum Ratings	6
3.0	Electrical Specifications	7
4.0	Optical Specifications	9
5.0	Interface Connections	14
6.0	Signal Timing Specifications	16
7.0	Signal Timing Waveforms	16
8.0	Input Signals, Basic Display Colors & Gray Scale of Colors	18
9.0	Power Sequence	19
10.0	Mechanical Characteristics	20
11.0	Mechanical Drawing	21
12.0	Reliability Test	24
13.0	Handling & Cautions	24
14.0	Labels	26
15.0	Packing Information	28
16.0	EDID	30

## 1.0 GENERAL DESCRIPTION

### 1.1 Introduction

HX121WX1-121 is a color active matrix TFT LCD module using amorphous silicon TFT's (Thin Film Transistors) as an active switching devices. This module has a 12.1 inch diagonally measured active area with WXGA resolutions (1280 horizontal by 800 vertical pixel array). Each pixel is divided into RED, GREEN, BLUE dots which are arranged in vertical Stripe and this module can display 262,144 colors. The TFT-LCD panel used for this module is a low reflection and higher color type.

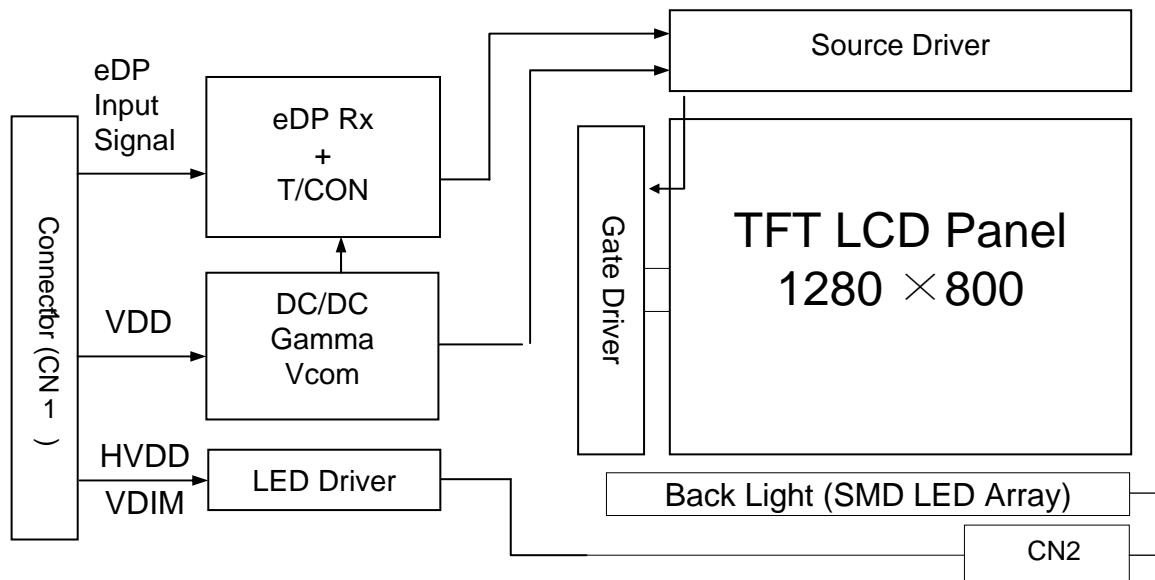

### 1.2 Features

- Thin and Light Weight
- 3.3 V Logic Power Supply
- 12V Back-light Power Supply
- 1 lane eDP Interface
- SMD LED (48EA) Array (Bottom Side/Horizontal Direction)
- 262,144 Colors
- Data Enable Signal Mode
- Side Mounting Frame
- Green Product (RoHS)



PRODUCT GROUP

REV

ISSUE DATE

TFT LCD PRODUCT

0

2010. 12.15

### 1.3 Application

- Tablet PC (Wide type)

### 1.4 General Specifications

Parameter	Specification	Unit	Remarks
Active area	261.12(H) × 163.20(V)	mm	
Number of pixels	1280(H) × 800(V)	pixels	
Pixel pitch	0.204(H) × 0.204(V)	mm	
Pixel arrangement	RGB Vertical Stripe		
Display colors	262,144	colors	
Display mode	Normally Black		
Outline dimension	276.8±0.3(H) × 180.0±0.3(V) × 6.8(D:Max.)	mm	Note 1
Weight	265(Typ.) / 275(Max.)	g	Note 2
Back-light	SMD LED (48EA) Array		
Surface treatment	AGLR, 3H		

Note 1 : At PCB side (LED Side: 4.6mm Max.)

Note 2 : Without digitizer

SPEC. NUMBER  
S864-1429

SPEC TITLE  
HX121WX1-121 Product Specification

PAGE  
5 OF 33



PRODUCT GROUP

REV

ISSUE DATE

TFT LCD PRODUCT

0

2010. 12.15

## 2.0 ABSOLUTE MAXIMUM RATINGS

The followings are maximum values which, if exceed, may cause faulty operation or damage to the unit.

Ta=25+/-2°C

Parameter	Symbol	Min.	Max.	Unit	Remarks
Logic Power Supply Voltage	V <sub>DD</sub>	-0.3	4.0	V	
Logic Power Supply Voltage	V <sub>IN</sub>	-0.3	V <sub>DD</sub> +0.3	V	
Back-light Power Supply Voltage	HV <sub>DD</sub>	-0.3	40	V	
Back-light LED Current	I <sub>LED</sub>	-	30	mA	Note 1
Back-light LED Reverse Voltage	V <sub>R</sub>	-	5	V	
Operating Temperature	T <sub>OP</sub>	0	+50	°C	Note 1, Note 2
Storage Temperature	T <sub>SP</sub>	-20	+60	°C	

Note 1. Ambient temperature vs allowable forward current are shown in the figure below.

Note 2. Temperature and relative humidity range are shown in the figure below.

90% RH Max. ( 40°C ≥ Ta)

Maximum wet - bulb temperature at 39°C or less. ( > 40°C ) No condensation.

Ambient Temperature vs. Maximum Forward Current

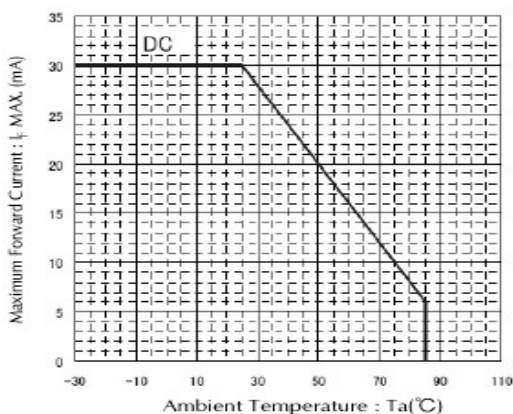

Relative Humidity

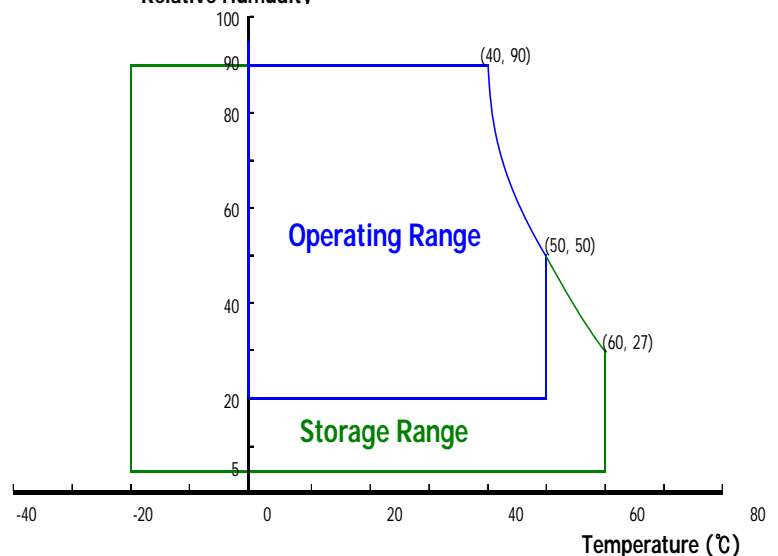

SPEC. NUMBER  
S864-1429

SPEC TITLE  
HX121WX1-121 Product Specification

PAGE  
6 OF 33

### 3.0 ELECTRICAL SPECIFICATIONS

#### 3.1 Electrical Specifications

< Table 3. Electrical Specifications >

Parameter		Min.	Typ.	Max.	Unit	Remarks
Logic Power Supply Voltage	$V_{DD}$	3.0	3.3	3.6	V	Note 1
Logic Power Supply Current	$I_{DD}$	-	346	470	mA	Note 1
Back-light Power Supply Voltage	$HV_{DD}$	7.0	12.0	20	V	Note 2
Back-light Power Supply Current	$I_{HVDD}$	-	255	305	mA	Note 2, 3
Back-light Power Consumption	$P_{BL}$	-	3.06	3.66	W	Note 2, 3
LED Driver's Efficiency	$\eta$	-	82	-	%	Note 2, 3
Back-light PWM Frequency	$F_{PWM}$	200	280	350	Hz	
High Level PWM Signal Voltage	$V_{PWMH}$	2.1	3.3	5.0	V	
Low Level PWM Signal Voltage	$V_{PWML}$	-	0	0.6	V	
High Level Differential Input Signal Voltage	$V_{IH}$	-	-	+100	mV	$V_{CM} = 1.2V$
Low Level Differential Input Signal Voltage	$V_{IL}$	-100	-	-	mV	
Back-light LED Voltage / Back-light LED Total Voltage	$V_{LED} / V_{BL}$	-	3.1 / 37.2	3.5 / 42.0	V	Note 4
Back-light LED Current / Back-light LED Total Current	$I_{LED} / I_{BL}$	-	16.9 / 67.6	17.8 / 71.2	mA	Note 4
Life Time		12,000	-	-	Hrs	Note 6
Power Consumption	$P_D$	-	1.14	1.55	W	Note 1
	$P_{LED}$	-	2.51	2.99	W	Note 4
	$P_{total}$	-	3.65	4.54	W	Note 1, 4

- Notes :
1. The supply voltage is measured and specified at the interface connector of LCM.  
The current draw and power consumption specified is for 3.3V at 25°C.  
a) Typ : Window XP pattern,      b) Max : Vertical Sub line pattern  
c) EBL : Mosaic pattern ( 32 X 32 )
  2. The power supply voltage and current is measured and specified at the interface connector of LCM including LED Driver.
  3. Reference value, which is measured with LED Driver for 12V.
  4. Reference value, which is measured without LED Driver.
  5. Calculated value for reference ( $V_{LED} \times I_{LED} \times \# \text{ of LEDs (48EA) }$ ).
  6. End of Life shall be determined by the time when any of the following is satisfied under continuous lighting at 25°C and  $I_{LED} = 16.9\text{mA}$ .
    - . Intensity drops to 50% of the Initial Value (Luminance Spec.)
    - . Based on LED

### 3.2 PWM Duty Ratio vs Brightness

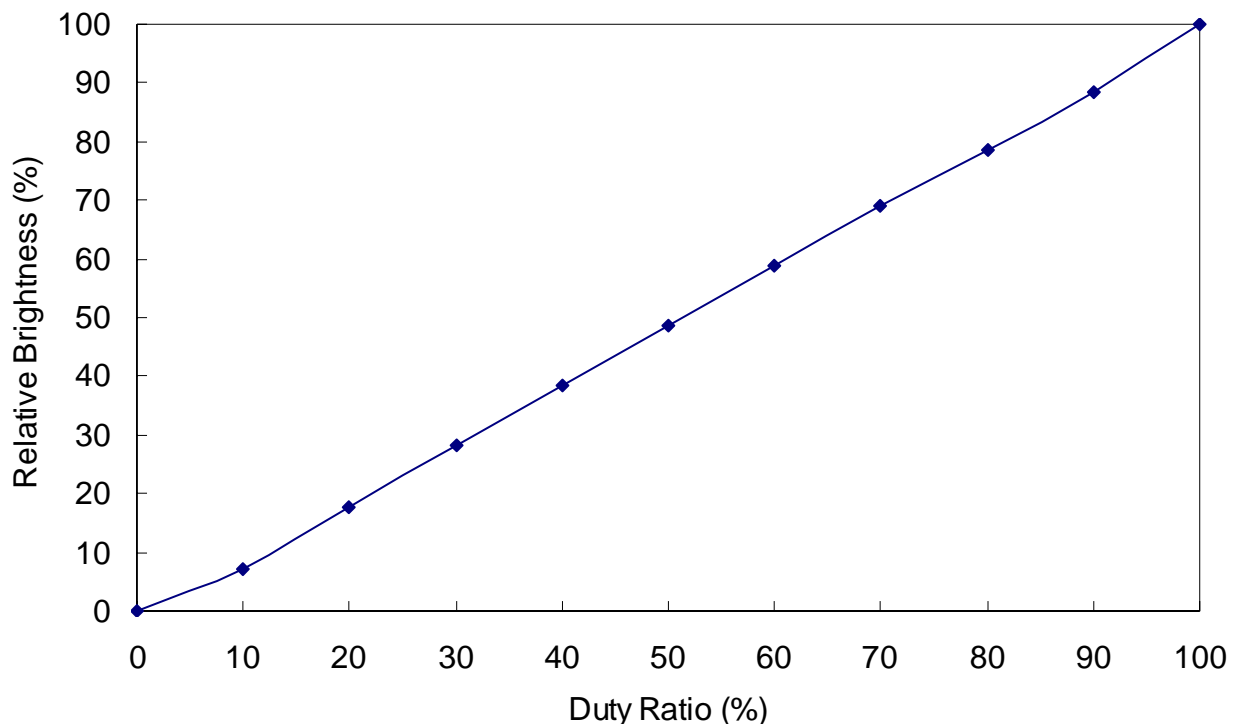





PRODUCT GROUP

REV

ISSUE DATE

TFT LCD PRODUCT

0

2010. 12.15

## 4.0 OPTICAL SPECIFICATIONS

### 4.1 Overview

The test of optical specifications shall be measured in a dark room (ambient luminance  $\leq 1$  lux and temperature =  $25 \pm 2^\circ\text{C}$ ) with the equipment of Luminance meter system (Goniometer system and TOPCON BM-5A) and test unit shall be located at an approximate distance 50cm from the LCD surface at a viewing angle of  $\Theta$  and  $\Phi$  equal to  $0^\circ$ . We refer to  $\Theta_{\varnothing=0}$  ( $=\Theta_3$ ) as the 3 o'clock direction (the "right"),  $\Theta_{\varnothing=90}$  ( $=\Theta_{12}$ ) as the 12 o'clock direction ("upward"),  $\Theta_{\varnothing=180}$  ( $=\Theta_9$ ) as the 9 o'clock direction ("left") and  $\Theta_{\varnothing=270}$  ( $=\Theta_6$ ) as the 6 o'clock direction ("bottom"). While scanning  $\Theta$  and/or  $\Phi$ , the center of the measuring spot on the Display surface shall stay fixed. The backlight should be operating for 30 minutes prior to measurement.  $V_{DD}$  shall be  $3.3 \pm 0.3\text{V}$  at  $25^\circ\text{C}$ . Optimum viewing angle direction is 6 o'clock.

### 4.2 Optical Specifications

<Table 4. Optical Specifications>

Parameter		Symbol	Condition	Min.	Typ.	Max.	Unit	Remarks
Viewing Angle Range	Horizontal	$\Theta_3$	CR > 10	-	85	-	Deg.	Note 1
		$\Theta_9$		-	85	-	Deg.	
	Vertical	$\Theta_{12}$		-	85	-	Deg.	
		$\Theta_6$		-	85	-	Deg.	
Luminance Contrast Ratio		CR		500	700	-		Note 2
Luminance of White	5 Points	$Y_w$		250	300	-	cd/m <sup>2</sup>	
White Luminance Uniformity	5 Points	$\Delta Y5$		80	-	-	%	Note 3
	13 Points	$\Delta Y13$		60	-	-		
Color Chromaticity	White	$W_x$	$\Theta = 0^\circ$	0.273	0.313	0.353		Note 4
		$W_y$		0.289	0.329	0.369		
	Red	$R_x$		0.528	0.568	0.608		
		$R_y$		0.333	0.373	0.413		
	Green	$G_x$		0.313	0.353	0.393		
		$G_y$		0.549	0.589	0.629		
	Blue	$B_x$		0.112	0.152	0.192		
		$B_y$		0.005	0.135	0.175		
Color Reproduction					42		%	
Response Time		Total ( $T_r + T_d$ )	Ta= $25^\circ\text{C}$ $\Theta = 0^\circ$	-	30	-	ms	Note 5
Cross Talk		CT	$\Theta = 0^\circ$	-	-	2.0	%	Note 6
Outdoor Spec.	Brightness	Center	$\Theta = 0^\circ$	400	500	-	cd/m <sup>2</sup>	Note 7
	Reflectance	Ri		2.5	3.5	-	%	Note 8

SPEC. NUMBER  
S864-1429

SPEC TITLE  
HX121WX1-121 Product Specification

PAGE  
9 OF 33



**HYDIS**

PRODUCT GROUP	REV	ISSUE DATE
TFT LCD PRODUCT	0	2010. 12.15

Note : 1. Viewing angle is the angle at which the contrast ratio is greater than 10. The viewing are determined for the horizontal or 3, 9 o'clock direction and the vertical or 6, 12 o'clock direction with respect to the optical axis which is normal to the LCD surface (see FIGURE 1 shown in page 11).

2. Contrast measurements shall be made at viewing angle of  $\Theta = 0^\circ$  and at the center of the LCD surface. Luminance shall be measured with all pixels in the view field set first to white, then to the dark (black) state. (See FIGURE 1 shown in page 11)

Luminance Contrast Ratio (CR) is defined mathematically.

$$CR = \frac{\text{Luminance when displaying a white raster}}{\text{Luminance when displaying a black raster}}$$

3. The White luminance uniformity on LCD surface is then expressed. (See FIGURE 2~3 shown in page 12)

$$\text{Uniformity } \Delta Y = \frac{\text{Minimum Luminance of 5(or 13) points}}{\text{Maximum Luminance of 5(or 13) points}} \times 100 (\%)$$

4. The color chromaticity coordinates specified in Table 4 shall be calculated from the spectral data measured with all pixels first in red, green, blue and white. Measurements shall be made at the center of the panel.

5. The electro-optical response time measurements shall be made as FIGURE 4 shown in page 13 by switching the "data" input signal OFF and ON. The times needed for the luminance to change from 10% to 90% is  $T_r$ , and 90% to 10% is  $T_d$ . (See FIGURE 4 shown in page 13)

6. Cross-Talk of one area of the LCD surface by another shall be measured by comparing the luminance (YA) of a 25mm diameter area, with all display pixels set to a gray level, to the luminance (YB) of that same area when any adjacent area is driven dark. (See FIGURE 5 shown in page 13)

7. Measure condition: Light source is 6,000nits, 15 degree position & BLU on at Full white. (See FIGURE 1 shown in page 11)

8. Reference : Standard White Plate (BaSO4)

$$\text{Reflectance} = \frac{\text{Light intensity of the reflected light on LCD Module}}{\text{Output intensity of the reflected light on Reference}} \times 100\%$$

Measure condition: Light source is 6,000nits, 15 degree position & BLU off at Full white. (See FIGURE 1 shown in page 11)

SPEC. NUMBER S864-1429	SPEC TITLE HX121WX1-121 Product Specification	PAGE 10 OF 33
---------------------------	--	------------------

### 4.3 Optical Measurements

**Figure 1. Measurement Set Up**

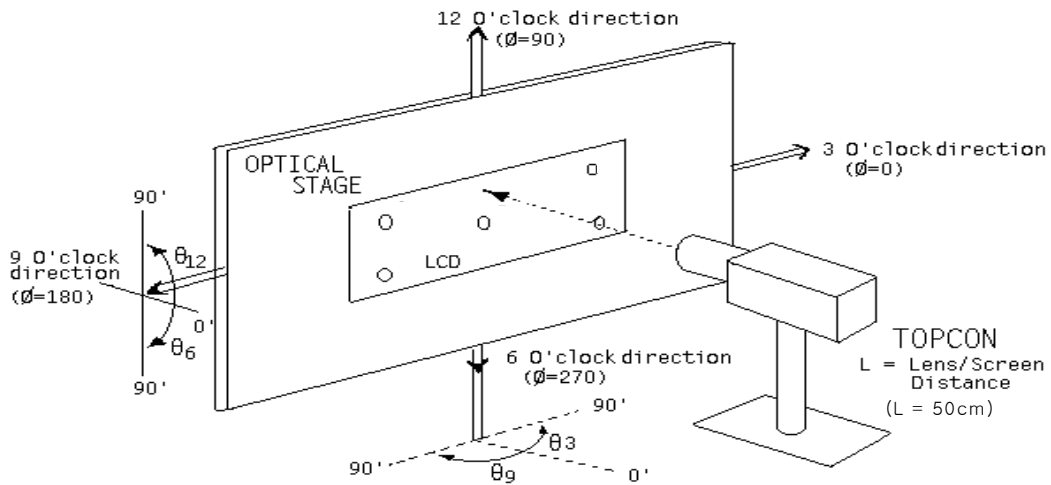

<Indoor>

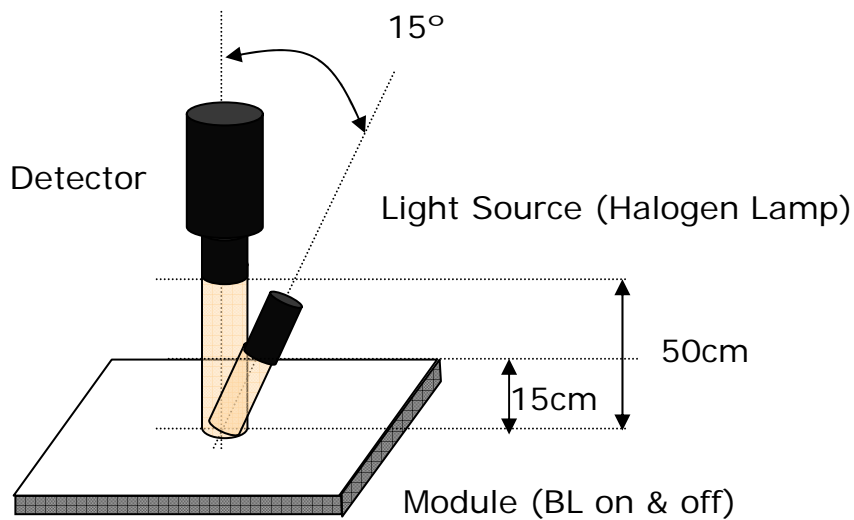

<Outdoor>

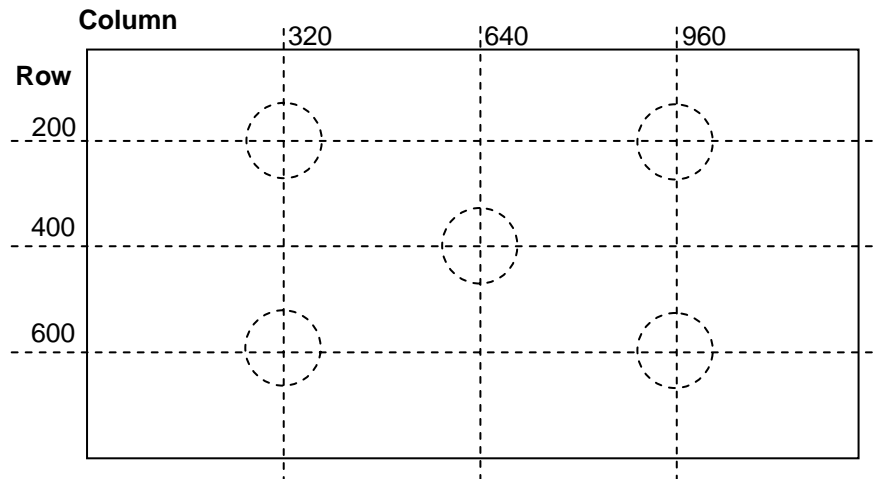
**Figure 2. White Luminance and Uniformity Measurement Locations (5 points)**

Note.

Luminance of white is defined as luminance values of 5 points across the LCD surface. Luminance shall be measured with all pixels in the view field set first to white. This measurement shall be taken at the locations shown in Figure 2 for a total of the measurements per display.

$$* Y_w = (\text{Sum of 5 Points Luminance} / 5)$$

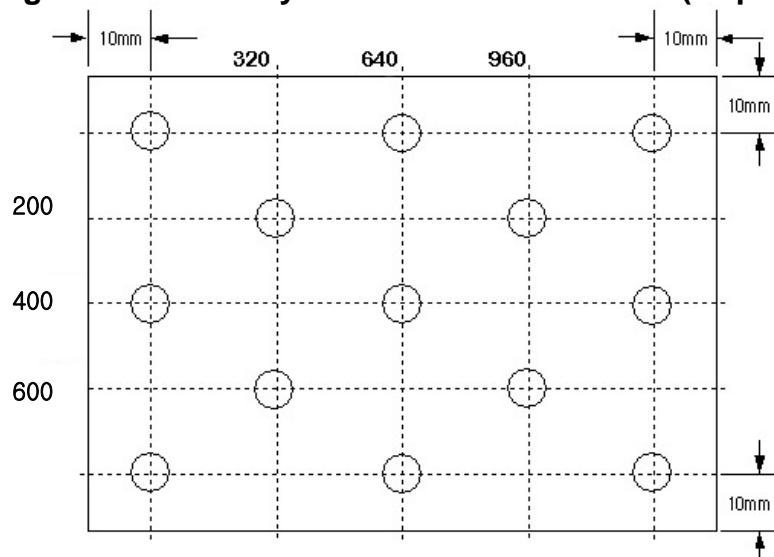
**Figure 3. Uniformity Measurement Locations (13 points)**

**Figure 4. Response Time Testing**

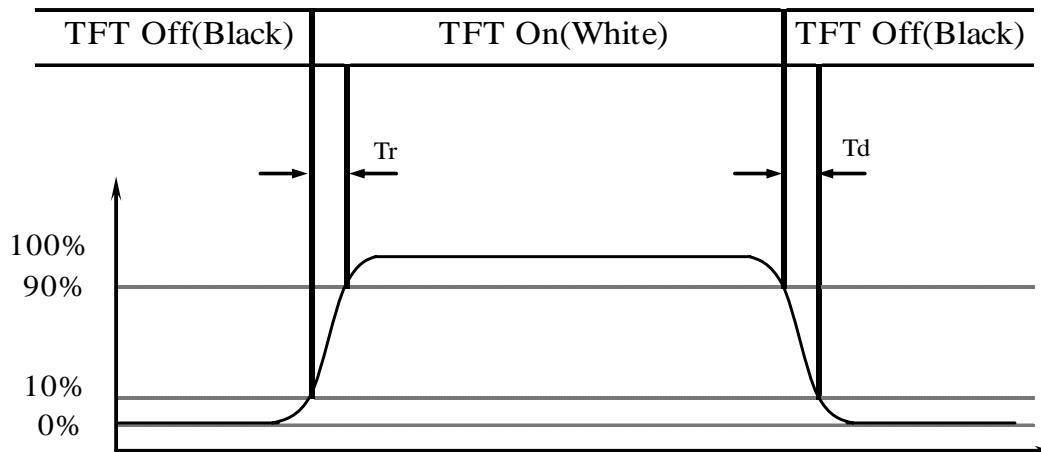

**Figure 5. Cross Modulation Test Description**

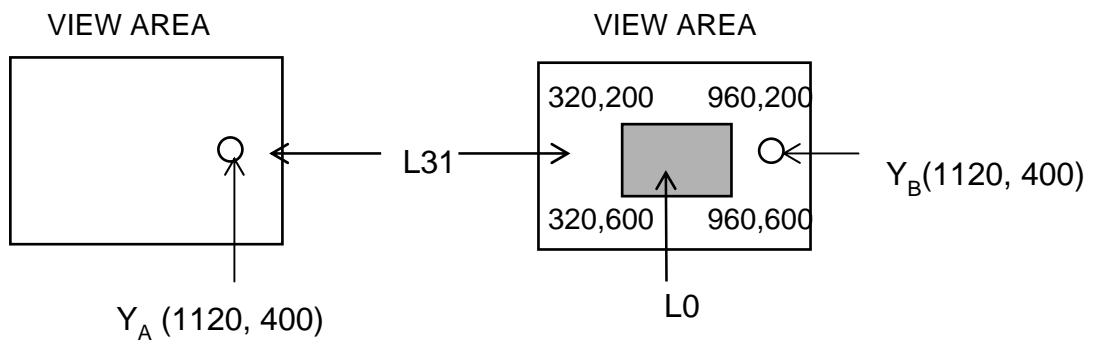

$$\text{Cross-Talk (\%)} = \left| \frac{Y_B - Y_A}{Y_B} \right| \times 100$$

Where:

$Y_A$  = Initial luminance of measured area (cd/m<sup>2</sup>)

$Y_B$  = Subsequent luminance of measured area (cd/m<sup>2</sup>)

The location measured will be exactly the same in both patterns



PRODUCT GROUP

REV

ISSUE DATE

TFT LCD PRODUCT

0

2010. 12.15

## 5.0 INTERFACE CONNECTIONS

### 5.1 Electrical Interface Connection

#### CN1 Interface Connector (I-PEX 20455-030E-02)

Pin	Signal	Description
1	EDID_Check	Hydis internal use for EDID verification
2	NC	No Connection (Reserved)
3	NC	No Connection (Reserved)
4	NC	No Connection (Reserved)
5	H_GND	High Speed (Main Link) Ground
6	ML_Lane 0 (n)	Complement Signal-Main Link Lane
7	ML_Lane 0 (p)	True Signal-Main Link Lane
8	H_GND	High Speed (Main Link) Ground
9	AUX_CH(p)	True Signal-Auxiliary channel
10	AUX_CH(n)	Complement Signal-Auxiliary
11	H_GND	High Speed (Main Link) Ground
12	VCC	VCC for Module (3.3V)
13	VCC	VCC for Module (3.3V)
14	BIST	Built-In Self Test (active high)
15	GND	Ground
16	GND	Ground
17	HPD	Hot Plug Detect
18	BL_GND	BL Ground
19	BL_GND	BL Ground
20	BL_GND	BL Ground
21	BL_GND	BL Ground
22	BL_EN	BL On/Off (On: 2.0~3.3V, Off: 0~0.5V) / NC (100K pull-up) / 5V tolerant
23	BL_PWM	PWM for luminance control (200~1KHz, 3.3V, 10~100%, 0V=off) 5V tolerant
24	EDID_Check	Hydis internal use for EDID verification
25	EDID_Check	Hydis internal use for EDID verification
26	VBL	BL Power 6V-20V
27	VBL	BL Power 6V-20V
28	VBL	BL Power 6V-20V
29	VBL	BL Power 6V-20V
30	EDID_Check	Hydis internal use for EDID verification

SPEC. NUMBER  
S864-1429SPEC TITLE  
HX121WX1-121 Product SpecificationPAGE  
14 OF 33

## 5.2 Back-light Interface

### CN2 LED FPC Connector (04-6298-009, Manufactured by Kyocera)

Pin No.	Symbol	Function	Remark
1	Anode1	LED Anode Power Supply	LED Anode Power Supply (3.1V X 12EA = 37.2V)
2	Anode2	LED Anode Power Supply	
3	Anode3	LED Anode Power Supply	
4	Anode4	LED Anode Power Supply	
5	NC	Non-Connection	
6	Cathode1	LED Cathode Power Supply	LED Cathode Power Supply
7	Cathode2	LED Cathode Power Supply	
8	Cathode3	LED Cathode Power Supply	
9	Cathode4	LED Cathode Power Supply	

## 5.3 Data Input Format

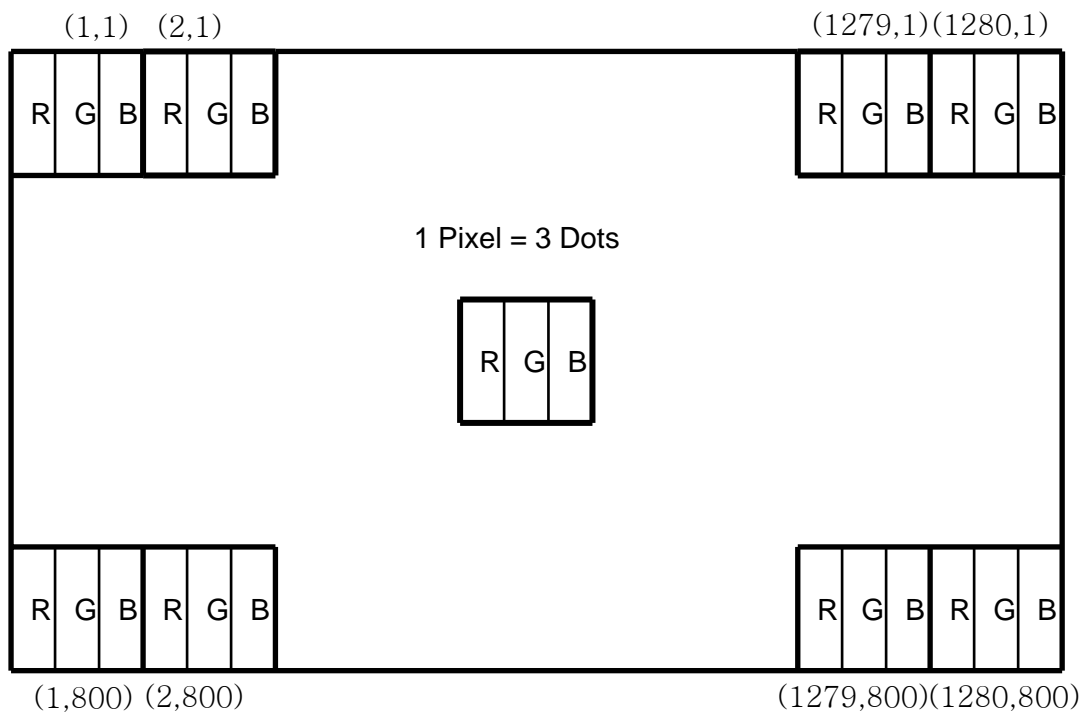

## 6.0. SIGNAL TIMING SPECIFICATIONS

6.1 The 12.1" WXGA LCM is operated by the only DE (Data enable) mode (LVDS Transmitter Input)

Item	Symbol	Min.	Typ.	Max.	Unit
Frame Period	T1	810	814	-	Lines
Vertical Display Period	T2	-	800	-	Lines
One line Scanning Period	T3	1350	1418	-	Clocks
Horizontal Display Period	T4	-	1280	-	Clocks
Clock Frequency	1/T5	-	69.3	-	MHz

## 7.0 SIGNAL TIMING WAVEFORMS

### 7.1 Timing Waveforms of Interface Signal

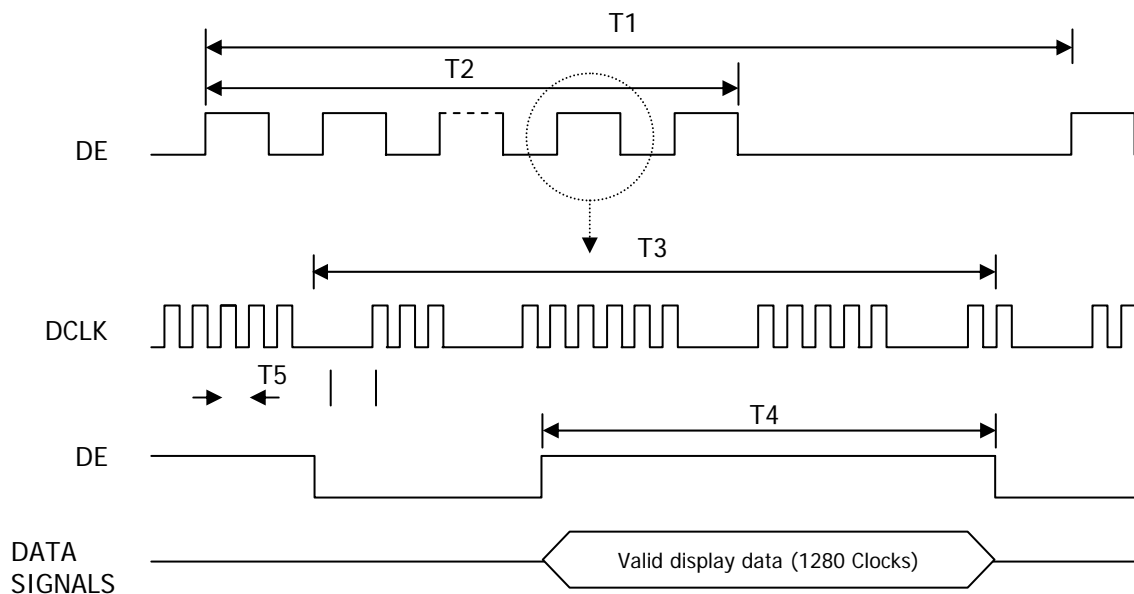



## 7.2 LVDS Rx Interface Timing Parameter

The specification of the LVDS Rx interface timing parameter

< LVDS Rx Interface Timing Specification >

Item	Symbol	Min.	Typ.	Max.	Unit	Remarks
CLKIN Period	tRCIP	12.50	14.43	25.00	nsec	
Input Data 0	tRIP0	-0.4	0.0	+0.4	nsec	
Input Data 1	tRIP1	tRCIP/7-0.4	tRCIP/7	tRCIP/7+0.4	nsec	
Input Data 2	tRIP2	2 × tRCIP/7-0.4	2 × tRCIP/7	2 × tRCIP/7+0.4	nsec	
Input Data 3	tRIP3	3 × tRCIP/7-0.4	3 × tRCIP/7	3 × tRCIP/7+0.4	nsec	
Input Data 4	tRIP4	4 × tRCIP/7-0.4	4 × tRCIP/7	4 × tRCIP/7+0.4	nsec	
Input Data 5	tRIP5	5 × tRCIP/7-0.4	5 × tRCIP/7	5 × tRCIP/7+0.4	nsec	
Input Data 6	tRIP6	6 × tRCIP/7-0.4	6 × tRCIP/7	6 × tRCIP/7+0.4	nsec	

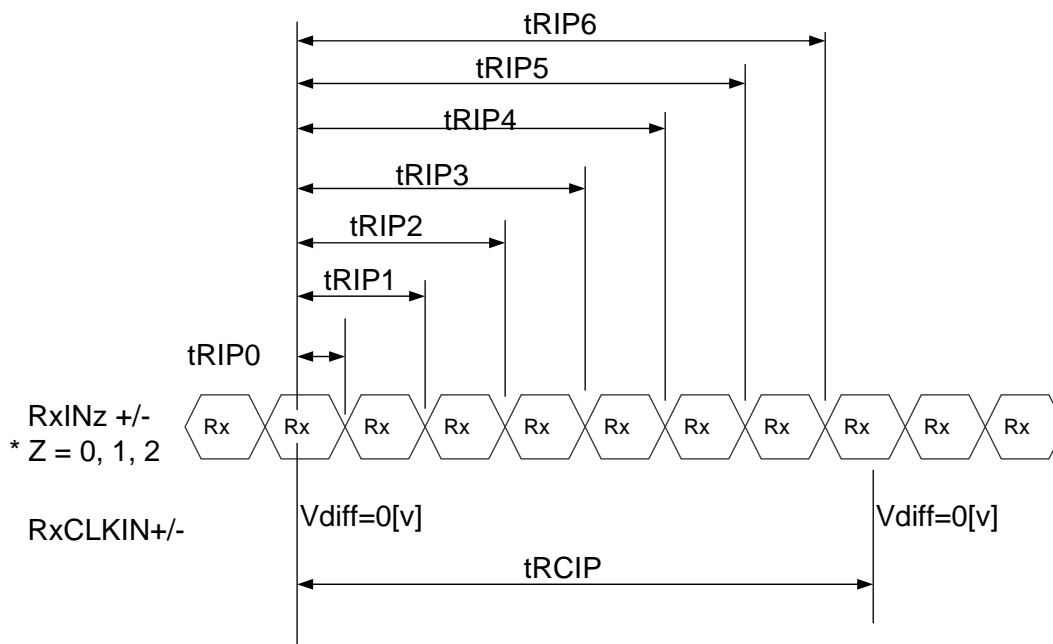



	PRODUCT GROUP	REV	ISSUE DATE
	TFT LCD PRODUCT	0	2010. 12.15

## 8.0 INPUT SIGNALS, BASIC DISPLAY COLORS & GRAY SCALE OF COLORS

Each color is displayed in sixty-four gray scales from a 6 bit data signal input. A total of 262,144 colors are derived from the resultant 18 bit data.

Colors & Gray Scale		Red Data						Green Data						Blue Data					
		R5	R4	R3	R2	R1	R0	G5	G4	G3	G2	G1	G0	B5	B4	B3	B2	B1	B0
Basic Colors	Black	0	0	0	0	0	0	0	0	0	0	0	0	0	0	0	0	0	0
	Blue	0	0	0	0	0	0	0	0	0	0	0	0	1	1	1	1	1	1
	Green	0	0	0	0	0	0	1	1	1	1	1	1	0	0	0	0	0	0
	Cyan	0	0	0	0	0	0	1	1	1	1	1	1	1	1	1	1	1	1
	Red	1	1	1	1	1	1	0	0	0	0	0	0	0	0	0	0	0	0
	Magenta	1	1	1	1	1	1	0	0	0	0	0	0	1	1	1	1	1	1
	Yellow	1	1	1	1	1	1	1	1	1	1	1	1	0	0	0	0	0	0
	White	1	1	1	1	1	1	1	1	1	1	1	1	1	1	1	1	1	1
Gray Scale Of Red	Black	0	0	0	0	0	0	0	0	0	0	0	0	0	0	0	0	0	0
	△	0	0	0	0	0	1	0	0	0	0	0	0	0	0	0	0	0	0
	Darker	0	0	0	0	1	0	0	0	0	0	0	0	0	0	0	0	0	0
	△	↓						↓						↓					
	▽	↓						↓						↓					
	Brighter	1	1	1	1	0	1	0	0	0	0	0	0	0	0	0	0	0	0
	▽	1	1	1	1	1	0	0	0	0	0	0	0	0	0	0	0	0	0
	Red	1	1	1	1	1	1	0	0	0	0	0	0	0	0	0	0	0	0
Gray Scale Of Green	Black	0	0	0	0	0	0	0	0	0	0	0	0	0	0	0	0	0	0
	△	0	0	0	0	0	0	0	0	0	0	0	1	0	0	0	0	0	0
	Darker	0	0	0	0	0	0	0	0	0	0	1	0	0	0	0	0	0	0
	△	↓						↓						↓					
	▽	↓						↓						↓					
	Brighter	0	0	0	0	0	0	1	1	1	1	0	1	0	0	0	0	0	0
	▽	0	0	0	0	0	0	1	1	1	1	1	0	0	0	0	0	0	0
	Green	0	0	0	0	0	0	1	1	1	1	1	1	0	0	0	0	0	0
Gray Scale Of Blue	Black	0	0	0	0	0	0	0	0	0	0	0	0	0	0	0	0	0	0
	△	0	0	0	0	0	0	0	0	0	0	0	0	0	0	0	0	0	1
	Darker	0	0	0	0	0	0	0	0	0	0	0	0	0	0	0	0	1	0
	△	↓						↓						↓					
	▽	↓						↓						↓					
	Brighter	0	0	0	0	0	0	0	0	0	0	0	0	1	1	1	1	0	1
	▽	0	0	0	0	0	0	0	0	0	0	0	0	1	1	1	1	1	0
	Blue	0	0	0	0	0	0	0	0	0	0	0	0	1	1	1	1	1	1
Gray Scale Of White & Black	Black	0	0	0	0	0	0	0	0	0	0	0	0	0	0	0	0	0	0
	△	0	0	0	0	0	1	0	0	0	0	0	1	0	0	0	0	0	1
	Darker	0	0	0	0	1	0	0	0	0	0	1	0	0	0	0	0	1	0
	△	↓						↓						↓					
	▽	↓						↓						↓					
	Brighter	1	1	1	1	0	1	1	1	1	1	0	1	1	1	1	1	0	1
	▽	1	1	1	1	1	0	1	1	1	1	1	0	1	1	1	1	1	0
	White	1	1	1	1	1	1	1	1	1	1	1	1	1	1	1	1	1	1

SPEC. NUMBER S864-1429	SPEC TITLE HX121WX1-121 Product Specification	PAGE 18 OF 33
---------------------------	--	------------------

## 9.0 POWER SEQUENCE

To prevent a latch-up or DC operation of the LCD module, the power on/off sequence shall be as shown in below

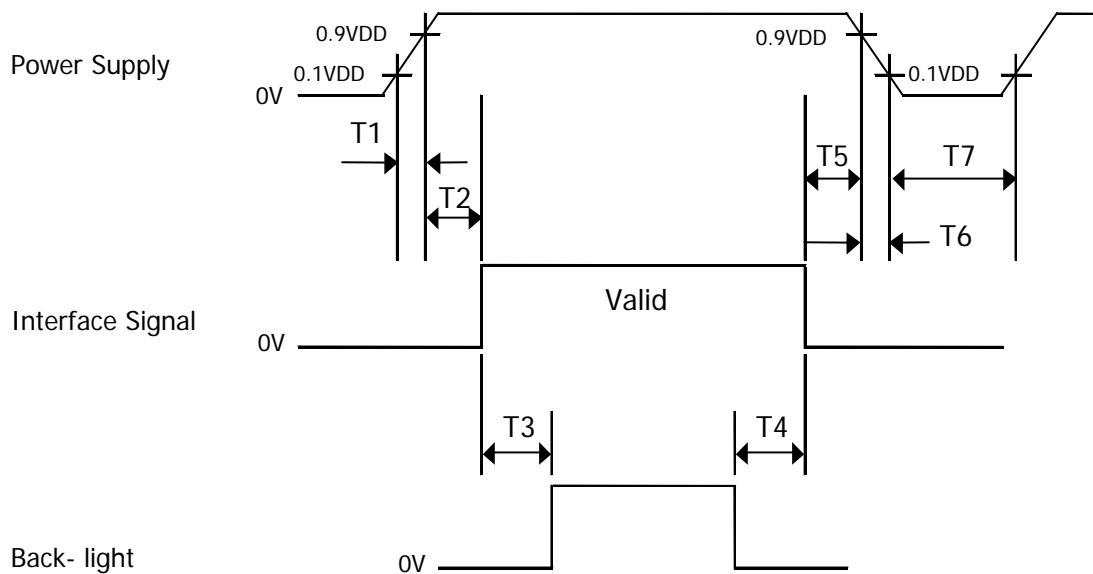

- $T1 \leq 10 \text{ ms}$
- $0 \leq T2 \leq 50 \text{ ms}$
- $200 \text{ ms} \leq T3$
- $200 \text{ ms} \leq T4$
- $0 \leq T5 \leq 50 \text{ ms}$
- $0 \leq T6 \leq 10 \text{ ms}$
- $500 \text{ ms} \leq T7$

Notes : 1. When the power supply VDD is 0V, Keep the level of input signals on the low or keep high impedance.

2. Do not keep the interface signal high impedance when power is on.

3. Back Light must be turn on after power for logic and interface signal are valid.

## 10.0 MECHANICAL CHARACTERISTICS

### 10.1 Dimensional Requirements

Figure 6 & 7 (located in 11.0) shows mechanical outlines for the model

Parameter	Specification	Unit
Active Area	261.12(H) X 163.20(V)	mm
Number of pixels	1280(H) X 800(V) (1 pixel = R + G + B dots)	
Pixel pitch	0.204(H) X 0.204(V)	
Pixel arrangement	RGB Vertical stripe	
Display colors	262,144	
Display mode	Normally Black	
Outline dimension	$276.8 \pm 0.3(H) \times 180.0(V) \pm 0.3 \times 6.8(D:Max.)$	mm
Weight	265(Typ.) / 275(Max.)	g
Back-light	SMD LED (48EA) Array	

### 10.2 Mounting

See Figure 6 & 7 & 8. (shown in 11.0)

Parameter	Specification	Unit
Torque of side mounting screw	2.5(Max.)	kgf
Torque of ground plate screw	1.5(Max.)	kgf
Torque of top side screw	2.5(Max.)	kgf

### 10.3 Anti-Glare and Polarizer Hardness.

The surface of the LCD have an anti-glare coating to minimize mirror image by reflection and a low reflection layer to decrease the reflection.

Polarizer hardness is 3H to protect the LCD from the surface scratch.

### 10.4 Light Leakage

There shall not be visible light from the back-lighting system around the edges of the screen as seen from a distance 50cm from the screen with an overhead light level of 150lux. The manufacture shall furnish limit samples of the panel showing the light leakage acceptable.

## 11.0 Mechanical Drawing

### Figure 6. TFT-LCD Module Outline Dimension (Front View)

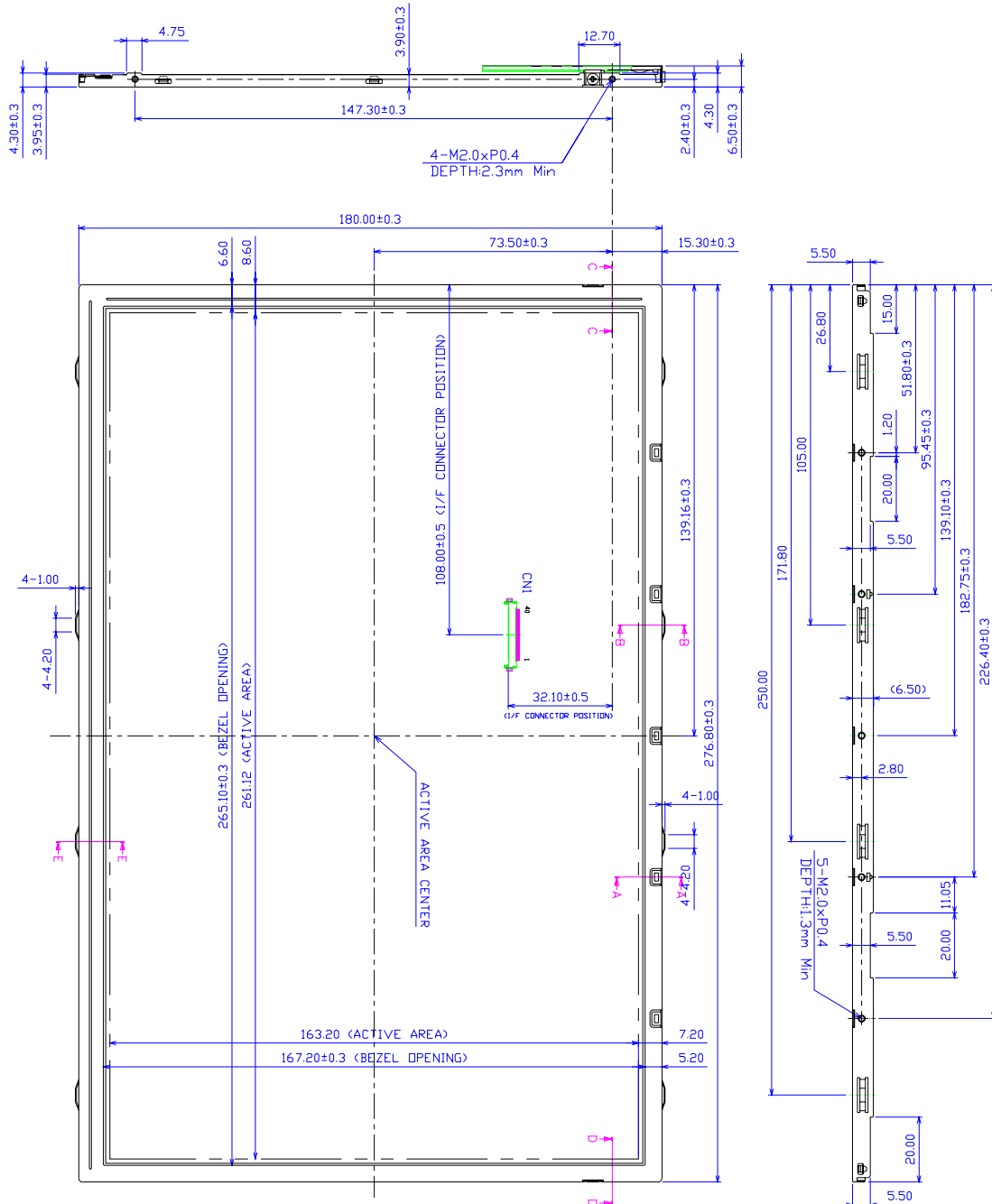
 SPEC. NUMBER  
 S864-1429

 SPEC TITLE  
 HX121WX1-121 Product Specification

 PAGE  
 21 OF 33

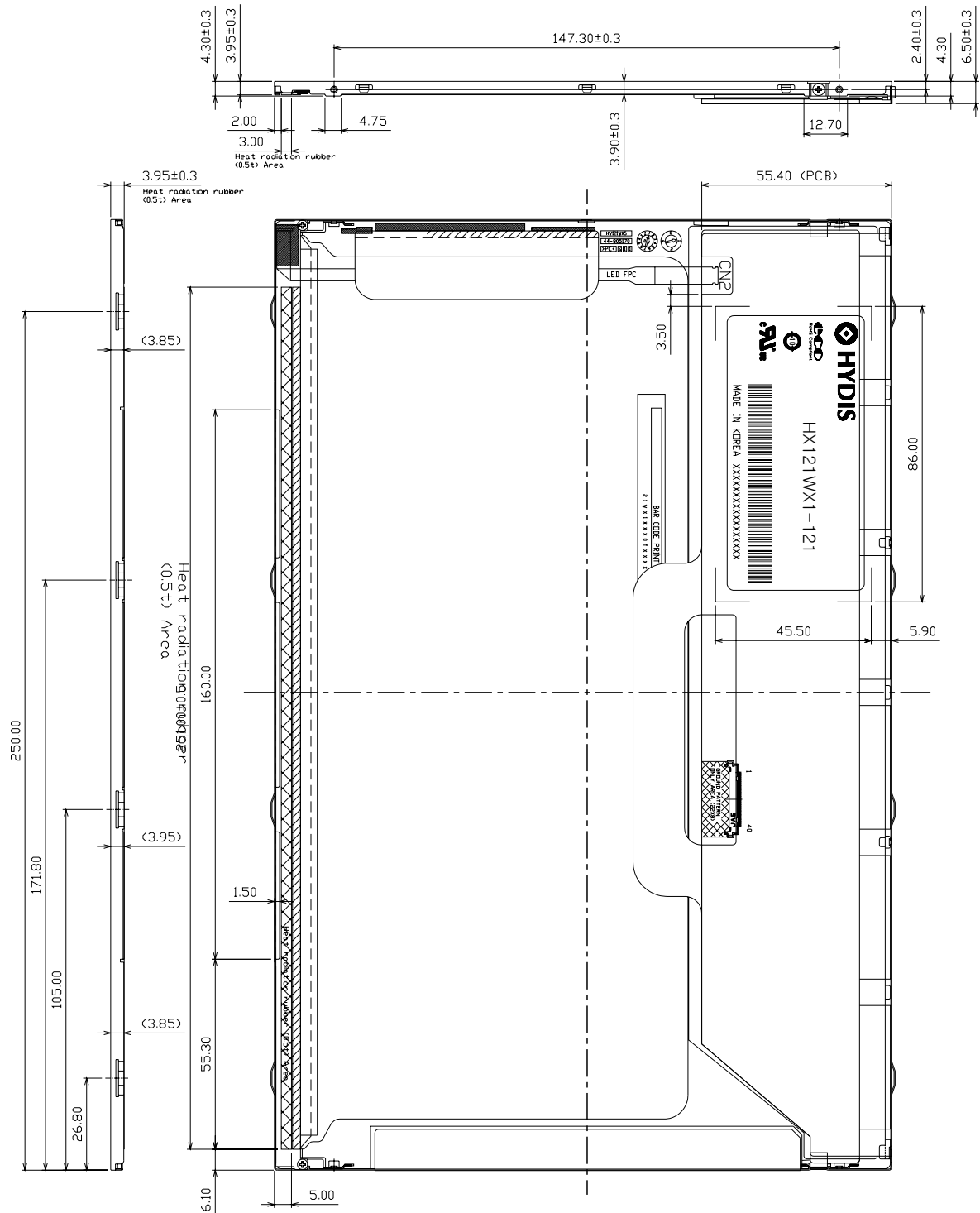
**Figure 7. TFT-LCD Module Outline Dimensions (Rear view)**

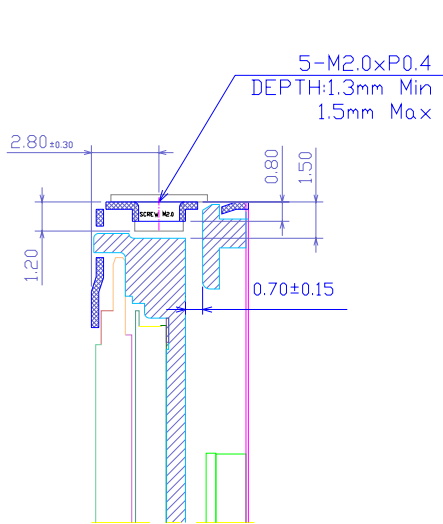
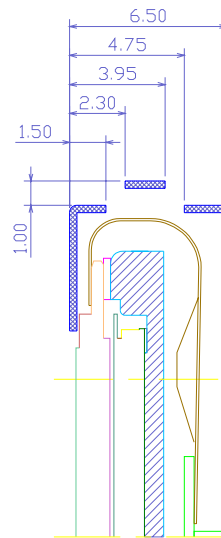
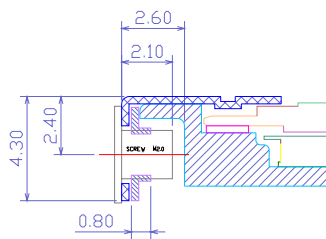
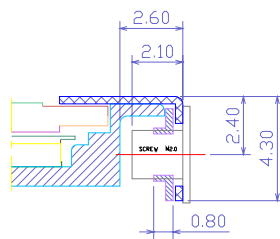
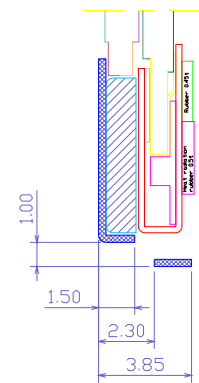
**Figure 8. TFT-LCD Module Section for Mounting**

SECTION A-A(S:5/1)

SECTION B-B(S:5/1)

SECTION C-C(S:5/1)

SECTION D-D(S:5/1)

SECTION E-E(S:5/1)

## 12.0 RELIABILITY TEST

The Reliability test items and its conditions are shown in below.

<Table 12. Reliability Test>

No	Test Item	Conditions
1	High temperature storage test	Ta = 60 °C, 240 hrs
2	Low temperature storage test	Ta = -20 °C, 240 hrs
3	High temperature & high humidity operation test	Ta = 50 °C, 80%RH, 240hrs
4	High temperature operation test	Ta = 50 °C, 240 hrs
5	Low temperature operation test	Ta = 0 °C, 240 hrs
6	Thermal shock	Ta = -20 °C ↔ 60 °C (30 min), 100 cycle
7	Vibration test (non-operating)	Frequency : 10~500Hz Gravity/AMP : 1.5G Period : X,Y,Z 30min
8	Shock test (non-operating)	Gravity : 220G Pulse width : 2ms, half sine wave ±X, ±Y, ±Z Once for each direction
9	Electro-static discharge test (non-operating)	Air : 150pF, 330ohm, 15KV Contact : 150pF, 330ohm, 8KV

## 13.0 HANDLING & CAUTIONS

### 13.1 Cautions when taking out the module

- Pick the pouch only, when taking out module from a shipping package.

### 13.2 Cautions for handling the module

- As the electrostatic discharges may break the LCD module, handle the LCD module with care. Peel a protection sheet off from the LCD panel surface as slowly as possible.
- As the LCD panel and back - light element are made from fragile glass (epoxy) material, impulse and pressure to the LCD module should be avoided.
- As the surface of the polarizer is very soft and easily scratched, use a soft dry cloth without chemicals for cleaning.
- Do not pull the interface connector in or out while the LCD module is operating.
- Put the module display side down on a flat horizontal plane.
- Handle connectors and cables with care.





**HYDIS**

PRODUCT GROUP	REV	ISSUE DATE
TFT LCD PRODUCT	0	2010. 12.15

**13.3 Cautions for the operation**

- When the module is operating, do not lose MCLK, DE signals. If any one of these signals were lost, the LCD panel would be damaged.
- Obey the supply voltage sequence. If wrong sequence is applied, the module would be damaged.

**13.4 Cautions for the atmosphere**

- Dew drop atmosphere should be avoided.
- Do not store and/or operate the LCD module in a high temperature and/or humidity atmosphere. Storage in an electro-conductive polymer packing pouch and under relatively low temperature atmosphere is recommended.

**13.5 Cautions for the module characteristics**

- Do not apply fixed pattern data signal to the LCD module at product aging.
- Applying fixed pattern for a long time may cause image sticking.

**13.6 Cautions for the digitizer assembly**

- When assembling FPC connector, do not flip connector past 90° due to possible damage to connector.
- When positioning digitizer underneath driver IC, do not lift driver IC past 90° due to possible damage to drive IC pattern.
- Please be warned that during assembly of digitizer, the opening or closing of FPC will result in possible electrostatic discharge damage to the LED

**13.7 Other cautions**

- Do not re-adjust variable resistor or switch etc.
- When returning the module for repair or etc., Please pack the module not to be broken. We recommend to use the original shipping packages.

SPEC. NUMBER S864-1429	SPEC TITLE HX121WX1-121 Product Specification	PAGE 25 OF 33
---------------------------	--	------------------



PRODUCT GROUP

REV

ISSUE DATE

TFT LCD PRODUCT

0

2010. 12.15

### 14.0 LABELS

#### 14.1 Product Label

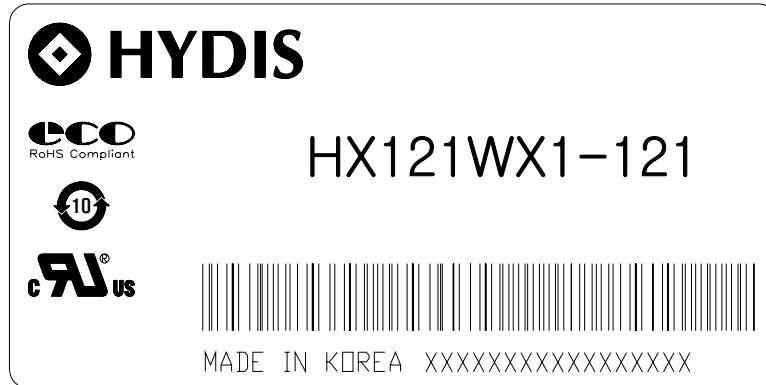

#### HYDIS Barcode

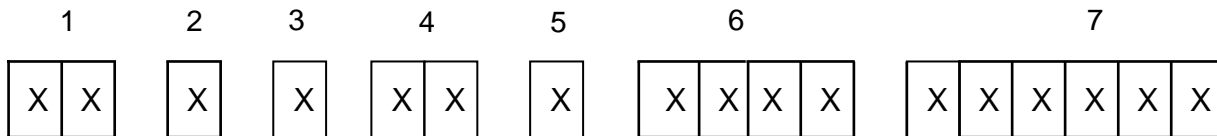

No 1. Control Number

No 5. Month (1, 2, 3,..., 9, X, Y, Z)

No 2. Rank / Grade

No 6. FG Code

No 3. Line Classification  
(HYDIS : H)

No 7. Serial Number

No 4. Year (5 : 2005, 6 : 2006, ...)

SPEC. NUMBER  
S864-1429

SPEC TITLE  
HX121WX1-121 Product Specification

PAGE  
26 OF 33



PRODUCT GROUP

REV

ISSUE DATE

TFT LCD PRODUCT

0

2010. 12.15

### 14.2 Packing Label

Label Size: 108 mm (L) × 56 mm (W)

Contents

Model: HX121WX1-121

Q`ty: Module Q`ty in one box

Serial No.: Box Serial No. See next figure for detail description.

Date: Packing Date

FG Code: FG Code of Product

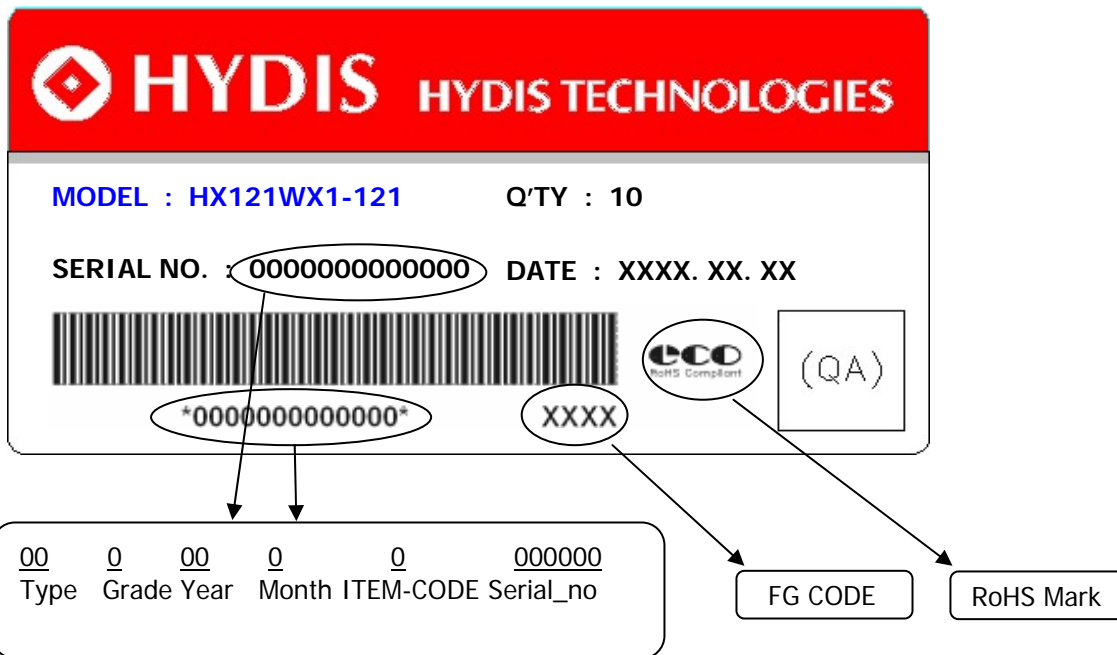

SPEC. NUMBER

S864-1429

SPEC TITLE

HX121WX1-121 Product Specification

PAGE

27 OF 33



## 15.0 PACKING INFORMATION

### 15.1 Packing order

Put Pad into the box.

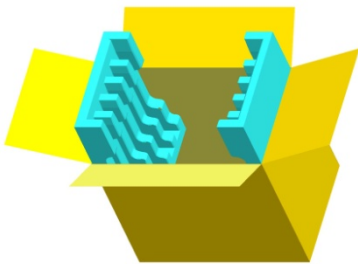

Put silica gels in the box.

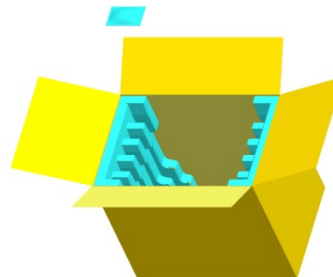

After sealing the box, attach Packing Label on the attach position sign area of the box.

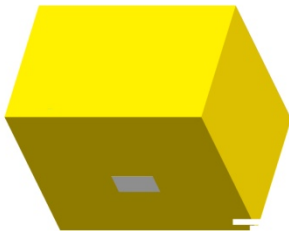

Place a cover on the top of the box.

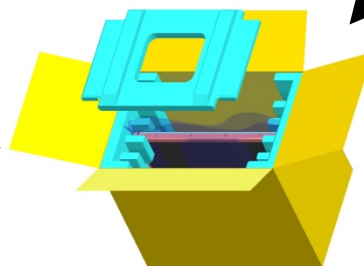

As shown in the figure, place the Modules bundled by shielding bag in the box.

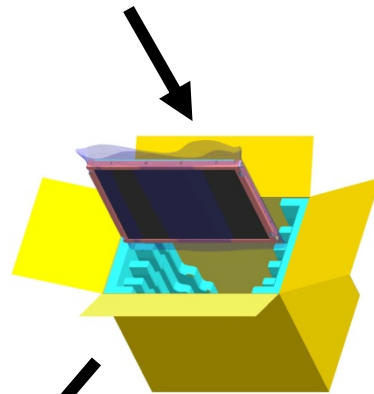

#### \* Notes

- Box Dimension : 349.0mm(W) X 261.0mm(D) X 311.0mm(H)
- Package Quantity in one Box : 10pcs

## 15.2 Pallet Packing

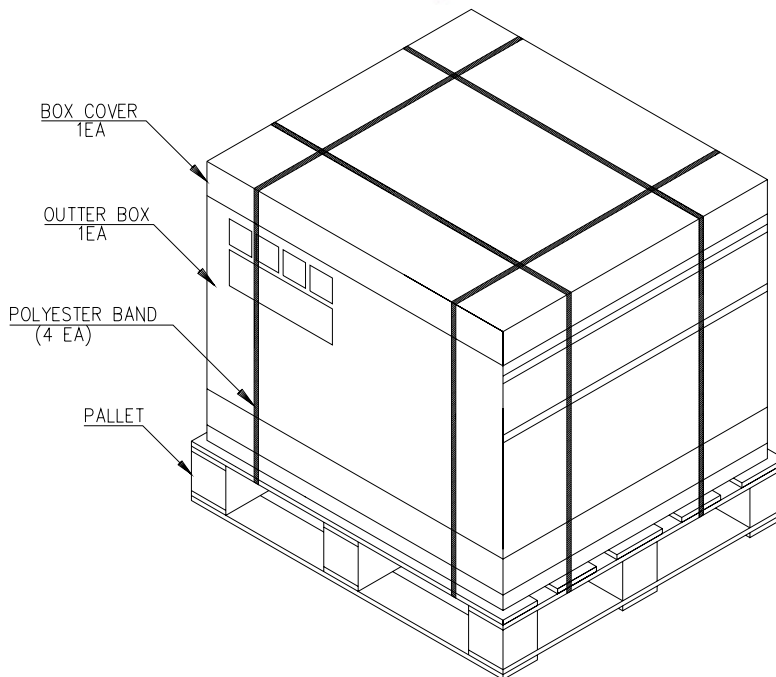
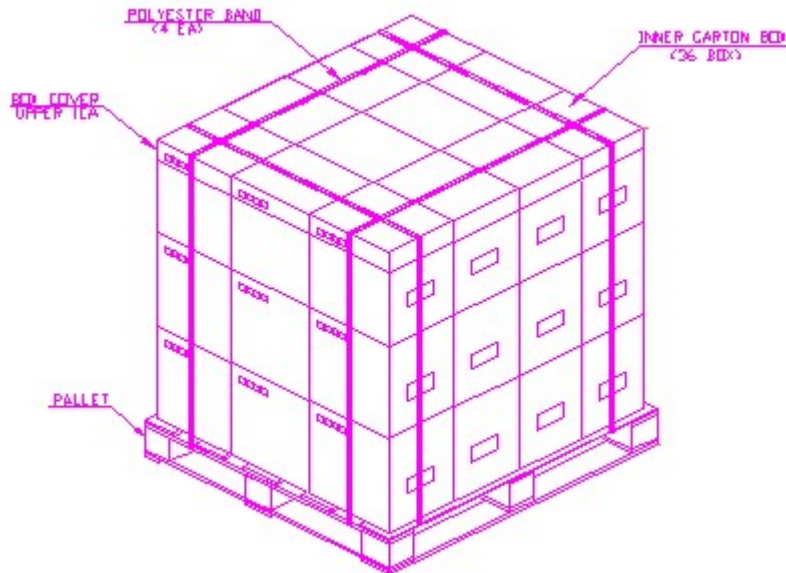

### \* Note

- Pallet Dimension : : 1100 mm (L) × 1100 mm (W) × 120 mm (H)
- Package Quantity in one Box : 10pcs
- Box Quantity in one Pallet : 36 box



PRODUCT GROUP

REV

ISSUE DATE

TFT LCD PRODUCT

0

2010. 12.15

## 16.0 EDID Table

Address (HEX)	Function	Hex	Dec	Input values.	Notes
00	Header	00	0	0	EDID Header
01		FF	255	255	
02		FF	255	255	
03		FF	255	255	
04		FF	255	255	
05		FF	255	255	
06		FF	255	255	
07		00	0	0	
08	ID Manufacturer Name	09	9	BOE	ID = BOE
09		E5	229		
0A	ID Product Code	A0	160	2208	ID = 2208
0B		08	8		
0C	32-bit serial No.	00	0		
0D		00	0		
0E		00	0		
0F		00	0		
10	Week of manufacture	0	0	0	
11	Year of Manufacture	13	19	2009	Manufactured in 2009
12	EDID Structure Ver.	01	1	1	EDID Ver 1.0
13	EDID revision #	04	4	4	EDID Rev. 0.4
14	Video input definition	95	149	-	Refer to right table
15	Max H image size	1A	26	26	26 cm (Approx)
16	Max V image size	10	16	16	16 cm (Approx)
17	Display Gamma	78	120	2.2	Gamma curve = 2.2
18	Feature support	2A	42		RGB display, Preferred Timming mode
19	Red/Green low bits	92	146	-	Red / Green Low Bits
1A	Blue/White low bits	75	117	-	Blue / White Low Bits
1B	Red x high bits	90	144	0.564	Red (x) = 10010000 (0.56416)
1C	Red y high bits	59	89	0.349	Red (y) = 01011001 (0.3491)
1D	Green x high bits	5A	90	0.352	Green (x) = 01011010 (0.35152)
1E	Green y high bits	90	144	0.565	Green (y) = 10010000 (0.5648)
1F	Blue x high bits	26	38	0.150	Blue (x) = 00100110 (0.14956)
20	BLue y high bits	1D	29	0.117	Blue (y) = 00011101 (0.1166)
21	White x high bits	50	80	0.313	White (x) = 01010000 (0.313)
22	White y high bits	54	84	0.329	White (y) = 01010100 (0.329)

SPEC. NUMBER  
S864-1429

SPEC TITLE  
HX121WX1-121 Product Specification

PAGE  
30 OF 33



PRODUCT GROUP

REV

ISSUE DATE

TFT LCD PRODUCT

0

2010. 12.15

Address (HEX)	Function	Hex	Dec	Input values.	Notes
23	Established timing 1	00	0	-	Refer to right table
24	Established timing 2	00	0	-	
25	Established timing 3	00	0	-	
26	Standard timing #1	01	1		Not Used
27		01	1		
28	Standard timing #2	01	1		Not Used
29		01	1		
2A	Standard timing #3	01	1		Not Used
2B		01	1		
2C	Standard timing #4	01	1		Not Used
2D		01	1		
2E	Standard timing #5	01	1		Not Used
2F		01	1		
30	Standard timing #6	01	1		Not Used
31		01	1		
32	Standard timing #7	01	1		Not Used
33		01	1		
34	Standard timing #8	01	1		Not Used
35		01	1		
36	Detailed timing/monitor descriptor #1	12	18	69.3000	69.3MHz (60.0388823237906Hz) Main clock
37		1B	27		
38		00	0	1280	Hor Active = 1280
39		8A	138	138	Hor Blanking = 138
3A		50	80	-	4 bits of Hor. Active + 4 bits of Hor. Blanking
3B		20	32	800	Ver Active = 800
3C		0E	14	14	Ver Blanking = 14
3D		30	48	-	4 bits of Ver. Active + 4 bits of Ver. Blanking
3E		1A	26	26	Hor Sync Offset = 26
3F		16	22	22	H Sync Pulse Width = 22
40		22	34	2	V sync Offset = 2 line
41		00	0	2	V Sync Pulse width : 2 line
42		05	5	261	Horizontal Image Size = 261 mm (Low 8 bits)
43		A3	163	163	Vertical Image Size = 163 mm (Low 8 bits)
44		10	16	-	4 bits of Hor Image Size + 4 bits of Ver Image Size
45		00	0	0	Hor Border (pixels)
46		00	0	0	Vertical Border (Lines)
47	19	25	-	Refer to right table	

SPEC. NUMBER  
S864-1429

SPEC TITLE  
HX121WX1-121 Product Specification

PAGE  
31 OF 33



PRODUCT GROUP

REV

ISSUE DATE

TFT LCD PRODUCT

0

2010. 12.15

Address (HEX)	Function	Hex	Dec	Input values.	Notes
48	Detailed timing/monitor descriptor #2 (sDRRS 40Hz)	0C	12	46.2000	Pixel Clock/10,000 (LSB)
49		12	18		Pixel Clock/10,000 (MSB)
4A		0	0	1280	Horizontal Addressable Pixels, lower 8 bits
4B		8A	138	138	Horizontal Blanking Pixels, lower 8 bits
4C		50	80	-	H Pixels, upper nibble : H Blanking, upper nibble
4D		20	32	800	Vertical Addressable Lines, lower 8 bits
4E		0E	14	14	Vertical Blanking Lines, lower 8 bits
4F		30	48	-	V lines, upper nibble : V blanking, upper nibble
50		1A	26	26	Horizontal Front Porch, lower 8 bits
51		16	22	22	Horizontal Sync Pulse, lower 8 bits
52		22	34	2	V Front Porch, lower nibble : V Sync Pulse, lower nibble
53		00	0	2	VFP, 2 bits: VSP 2 bits: HFP 2 bits: HFP 2 bits
54		05	5	261	Horizontal Image Size in mm, lower 8 bits
55		A3	163	163	Vertical Image Size in mm, lower 8 bits
56		10	16	-	H Image Size, upper nibble : V Image Size, upper nibble
57		00	0	0	Horizontal Border
58		00	0	0	Vertical Border
59		19	25	-	Bit Encode Sync Information
5A		Detailed timing/monitor descriptor #3 (nvDPS)	00	0	0
5B	00		0	0	
5C	00		0	0	
5D	00		0	0	
5E	00		0	0	
5F	00		0	0	
60	00		0	0	
61	00		0	0	
62	00		0	0	
63	00		0	0	
64	00		0	0	
65	00		0	0	
66	00		0	0	
67	00		0	0	
68	00	0	0		
69	00	0	0		
6A	00	0	0		
6B	00	0	0		

SPEC. NUMBER  
S864-1429

SPEC TITLE  
HX121WX1-121 Product Specification

PAGE  
32 OF 33





PRODUCT GROUP

REV

ISSUE DATE

TFT LCD PRODUCT

0

2010. 12.15

Address (HEX)	Function	Hex	Dec	Input values.	Notes	
6C	Detailed timing/monitor descriptor #4 (Brightness Table)	00	0	0	Detailed Timing Description #4	
6D		00	0	0	Flag	
6E		00	0	0	Reserved	
6F		02	2	2	For Brightness Table and Power consumption	
70		00	0	0	Flag	
71		19	25	-	PWM 10% [7:0] @ Step 0	
72		28	40	-	PWM 16% [7:0] @ Step 5	
73		C9	201	-	PWM 79% [7:0] @ Step 10	
74		25	37	-	37Nits [7:0] @ Step 0	
75		3C	60	-	60Nits [7:0] @ Step 5	
76		96	150	-	300Nits [7:0] @ Step 10	
77		1F	31	1240	Panel Electronics Power @32x32 Chess Pattern	
78		14	20	800	Backlight Power @60 nits	
79		22	34	2740	Backlight Power @Step 10	
7A		6E	110	220	Nits @ 100% PWM Duty	
7B		00	0	0	Flags	
7C		00	0	0	Flags	
7D		00	0	0	Flags	
7E		Extension flag	00	0	0	
7F		Checksum	5F	95	-	

SPEC. NUMBER  
S864-1429

SPEC TITLE  
HX121WX1-121 Product Specification

PAGE  
33 OF 33