



Features

- Up to 94% Efficiency
- Low voltage start-up: 0.9V
- Shut-down current: $< 1\mu\text{A}$
- Input voltage: 0.9V~4.4V
- Output voltage: 2.5V~4.3V (Up to 5V with Schottky)
- Low switch on resistance $R_{DS(ON)}$, Internal switch: 0.35Ω
- 1.4MHz fixed frequency switching
- Automatic PWM/PFM mode switching
- High switch on current: 0.9A
- Low profile SOT-23-6 package (lead-free packaging is now available)

Applications

- Digital cameras and MP3
- Palmtop computers / PDAs
- Cellular phones
- Wireless handsets and DSL modems
- PC cards
- Portable media players

Description

The HX3001 is high efficiency synchronous, PWM step-up DC/DC converters optimized to provide a high efficient solution to medium power systems. The devices work under the input voltage between 0.9V and 4.4V with a 1.4MHz fixed frequency switching. These features minimize overall solution footprint by allowing the use of tiny, low profile inductors and ceramic capacitors. Automatic PWM/PFM mode switching at light load saves power and improves efficiency.

The HX3001 is capable of supplying an output voltage between 2.5V and 4.3V, the internal synchronous switch is desired to provide high efficiency without Schottky.

The devices also featured providing up to 260mA from a single AA cell input or up to 600mA from a 2-cell AA with a 3V/3.3V output.

The HX3001 regulators are available in the industry standard SOT-23-6 power packages (or upon request).

Order Information

HX3001 - ① ②

SYMBOL	DESCRIPTION
①	Denotes Output voltage: A : Adjustable Output
②	Denotes Package Types: F: SOT-23-6

Typical Application

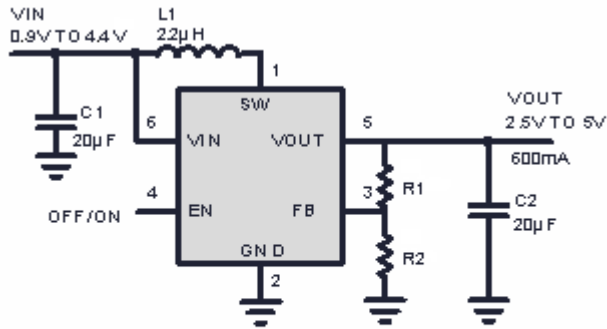

*LOCATE COMPONENTS CLOSE TO THE PIN
 C1: TAIYO YUDEN X5R JMK212BJ206MM
 C2: TAIYO YUDEN X5R JMK212BJ206MM
 D1: MOTOROLA MBR0520L
 L1: COILCRAFT D0160C-222

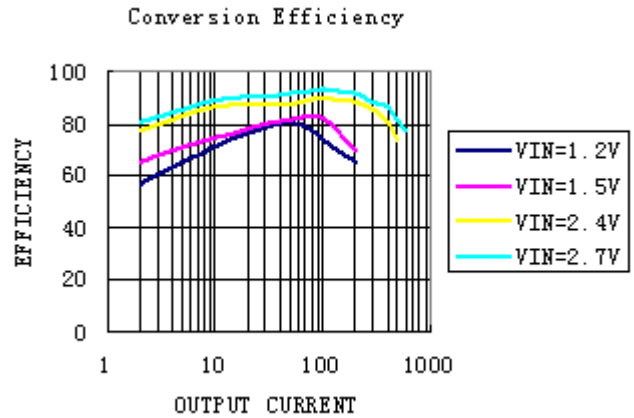

Absolute Maximum Ratings

- Power Dissipation.....Internally limited
- V_{IN}- 0.3 V ~ + 6.6V
- V_{OUT}- 0.3 V ~ + 6.6V
- V_{SW}- 0.3 V ~ + 6.6 V
- V_{EN}, V_{OUT}- 0.3 V ~ + 6.6 V
- Operating Temperature Range- 30°C ~ + 85°C
- Lead Temperature (Soldering 10 sec.)+ 300°C
- Storage Temperature Range- 65°C ~ + 125°C

Pin Assignment

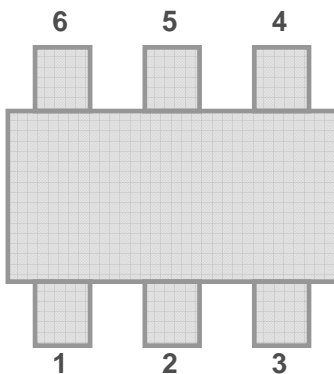

PIN NUMBER SOT-23-6	PIN NAME	FUNCTION
1	SW	Switch Output
2	GND	Ground
3	FB	Feedback
4	EN	ON/OFF Control (High Enable)
5	V_{OUT}	Output
6	V_{IN}	Input

Electrical Characteristics

Operating Conditions: $T_A=25^{\circ}\text{C}$, $V_{IN}=1.2\text{V}$, $V_{OUT}=3.3\text{V}$ unless otherwise specified.

PARAMETER	CONDITIONS	MIN	TYP	MAX	UNITS
Output Voltage Range (Adj.)		2.5		5	V
Minimum Start-Up Voltage	$I_{LOAD} = 1\text{mA}$		0.9	1.1	V
Minimum Operating Voltage	$EN = V_{IN}$		0.6	0.75	V
Switching Frequency		1.1	1.4	1.7	MHz
Max Duty Cycle	$V_{FB} = 1.15\text{V}$	80	87		%
Current Limit Delay to Output			40		ns
Feedback Voltage		1.165	1.212	1.241	V
Feedback Input Current	$V_{FB} = 1.22\text{V}$		1		nA
NMOS Switch Leakage	$V_{SW} = 5\text{V}$		0.1	5	μA
PMOS Switch Leakage	$V_{SW} = 0\text{V}$		0.1	5	μA
NMOS Switch On Resistance	$V_{OUT} = 3.3\text{V}$		0.35		Ω
PMOS Switch On Resistance	$V_{OUT} = 3.3\text{V}$		0.45		Ω
NMOS Current Limit		700	950		mA
Quiescent Current (Active)	Measured On V_{OUT} , No switching		260		μA
Shutdown Current	$V_{EN}=0\text{V}$, Including Switch Leakage		0.1	1	μA
En Input High		1			V
En Input Low				0.35	V
En Input Current	$V_{EN} = 5.5\text{V}$		0.01	1	μA

Typical Performance Characteristics

$V_{OUT}=3.3V$

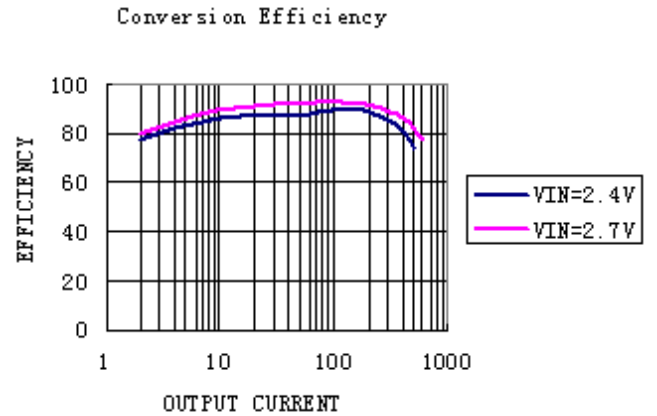
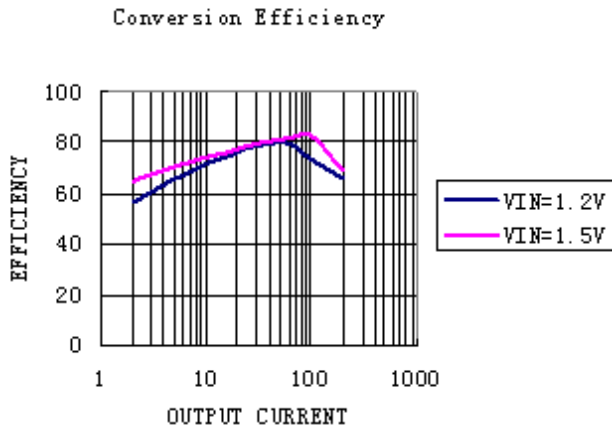
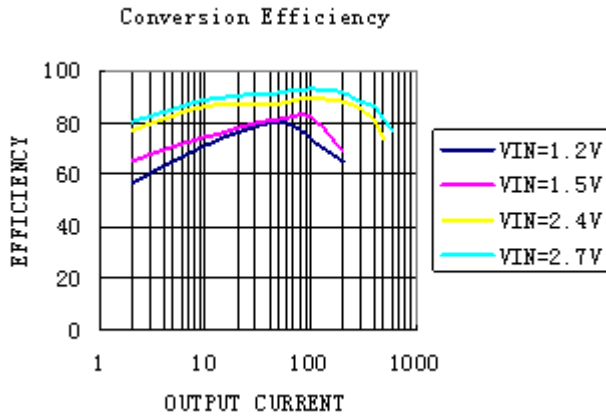

$V_{OUT}=5V$

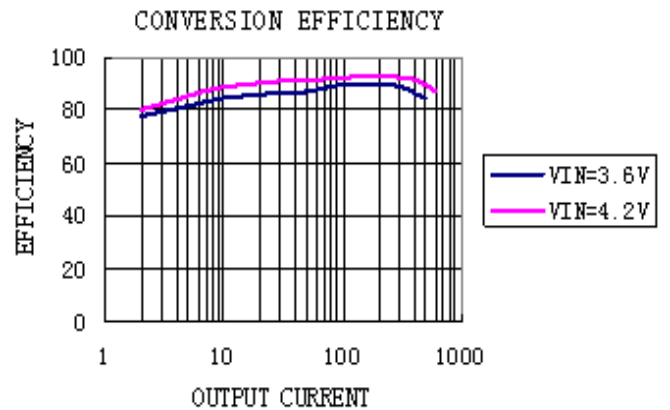
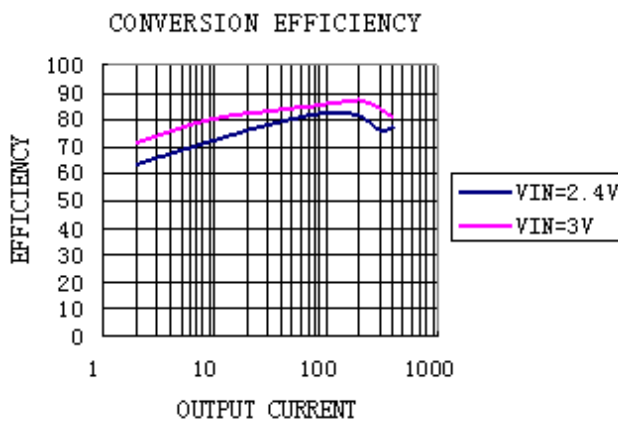

Application Information

SW (Pin 1): Switch Pin. Connect inductor between SW and V_{IN} . Keep these PCB trace lengths as short and wide as possible to reduce EMI and voltage overshoot.

GND (Pin 2): Signal and Power Ground. Provide a short direct PCB path between GND and the (-) side of the output capacitor(s).

FB (Pin 3): Feedback Input to the g_m Error Amplifier. Connect resistor divider tap to this pin. The output voltage can be adjusted from 2.5V to 5V by: $V_{OUT} = 1.212V \cdot [1 + (R1/R2)]$

EN (Pin 4): Logic Controlled Shutdown Input. EN = High: Normal free running operation, 1.4MHz typical operating frequency. EN = Low:

Shutdown, quiescent current $<1\mu A$. Output capacitor can be completely discharged through the load or feedback resistors.

V_{OUT} (Pin 5): Output Voltage Sense Input and Drain of the Internal Synchronous Rectifier MOSFET. Bias is derived from V_{OUT} . PCB trace length from V_{OUT} to the output filter capacitor(s) should be as short and wide as possible.

V_{IN} (Pin 6): Battery Input Voltage. The device gets its start-up bias from V_{IN} . Once V_{OUT} exceeds V_{IN} , bias comes from V_{OUT} . Thus, once started, operation is completely independent from V_{IN} . Operation is only limited by the output power level and the battery's internal series resistance.

Functional Diagram

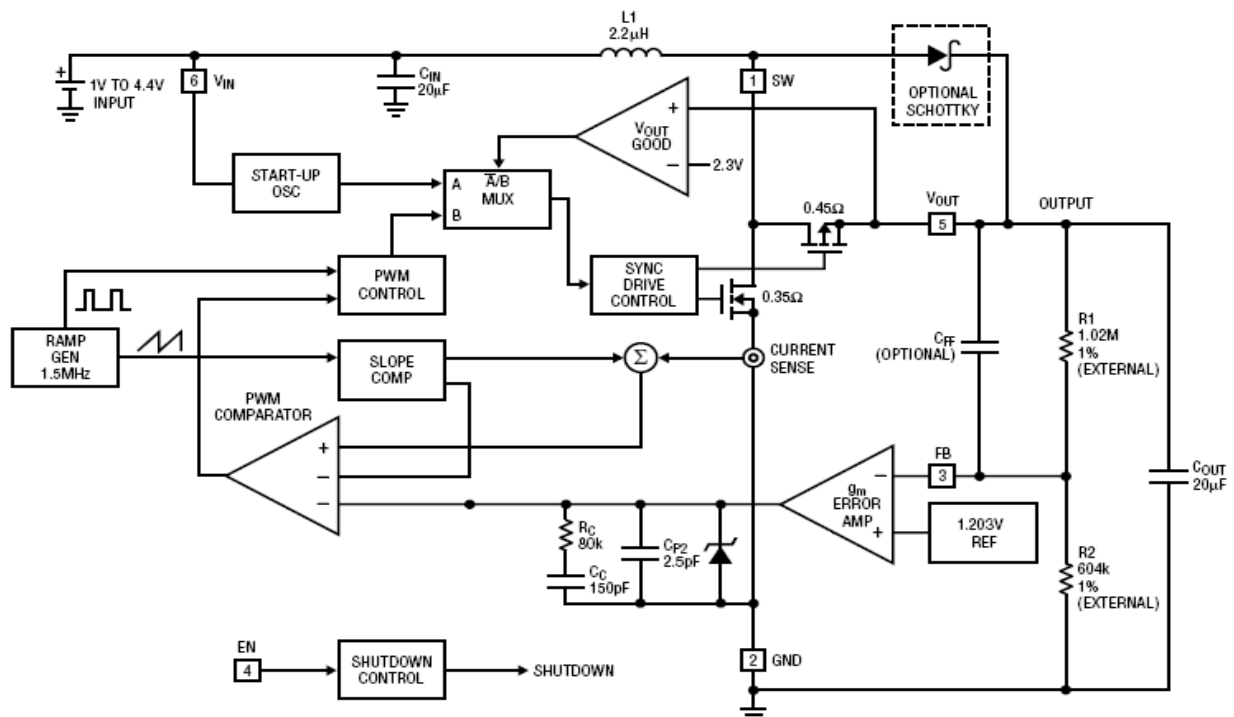

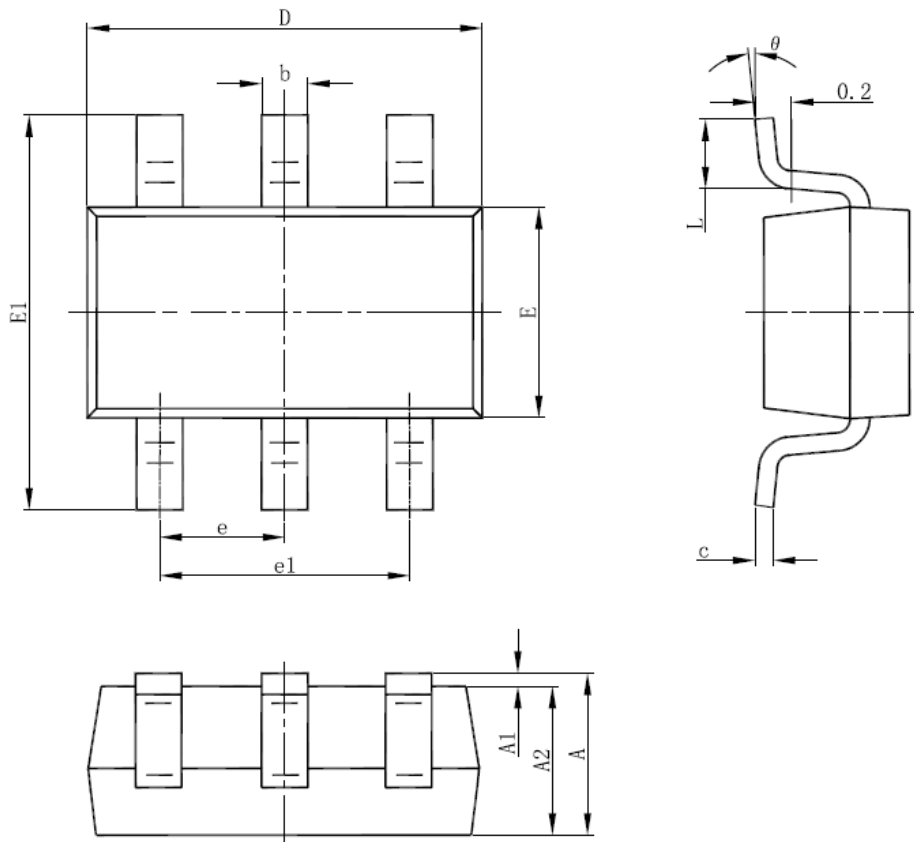
Packaging Information

Symbol	Dimensions In Millimeters		Dimensions In Inches	
	Min	Max	Min	Max
A	1.050	1.250	0.041	0.049
A1	0.000	0.100	0.000	0.004
A2	1.050	1.150	0.041	0.045
b	0.300	0.500	0.012	0.020
c	0.100	0.200	0.004	0.008
D	2.820	3.020	0.111	0.119
E	1.500	1.700	0.059	0.067
E1	2.650	2.950	0.104	0.116
e	0.950(BSC)		0.037(BSC)	
e1	1.800	2.000	0.071	0.079
L	0.300	0.600	0.012	0.024
θ	0°	8°	0°	8°