

800mA Standalone Linear Li-Ion Battery Charger

General Description

The HX4056A is a complete constant-current/constant-voltage linear charger for single cell lithium-ion batteries. Its ESOP8 package and low external component count make the HX4056A ideally suited for portable applications. Furthermore, the HX4056A is specifically designed to work within USB power specifications. No external sense resistor is needed, and no blocking diode is required due to the internal MOSFET architecture. Thermal feedback regulates the charge current to limit the die temperature during high power operation or high ambient temperature. The charge voltage is fixed at 4.2V, and the charge current can be programmed externally with a single resistor. The HX4056A automatically terminates the charge cycle when the charge current drops to 1/10th the programmed value after the final float voltage is reached. When the input supply (wall adapter or USB supply) is removed, the HX4056A automatically enters a low current state, dropping the battery drain current to less than 1 μ A. Other features include charge current monitor, automatic recharge and a status pin to indicate charge termination and the presence of an input voltage.

Order Information

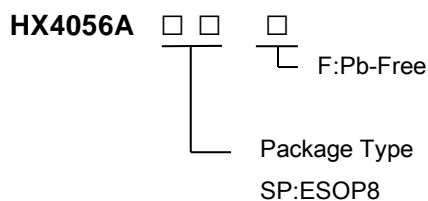

Applications

- ◇ Portable Media Players/MP3 players
- ◇ Cellular and Smart mobile phone
- ◇ PDA/DSC
- ◇ Bluetooth Applications

Features

- ◆ Programmable Charge Current up to 800mA
- ◆ No MOSFET, Sense Resistor or Blocking Diode Required
- ◆ Constant-Current/Constant-Voltage Operation with Thermal Regulation to Maximize
- ◆ Charge Rate Without Risk of Overheating
- ◆ 4.2V Charge Voltage with $\pm 1\%$ Accuracy
- ◆ Charge Current Monitor Output for Gas Gauging
- ◆ Automatic Recharge
- ◆ 2.9V Trickle Charge Threshold
- ◆ C/10 Charge Termination
- ◆ Output OCP
- ◆ Charging OTP
- ◆ Package in ESOP8

Typical Application Circuit

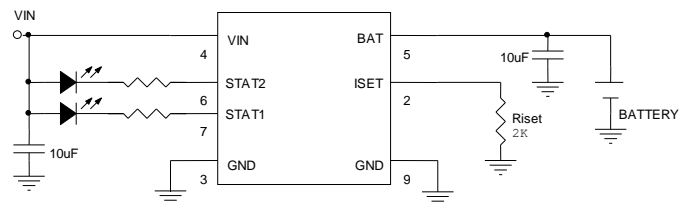

Marking Information

Part	Marking	Package	Shipping
HX4056A	4056A	ESOP8	4K/REEL
Marking indication: Y:Production year W:Production week X:Production batch.			

Functional Pin Description

Package Type	Pin Configurations
ESOP8	

Pin	Name	Description
1、 8	NC	No Connector.
2	ISET	Charge Current Program and Charge Current Monitor Pin. The charge current is programmed by connecting a 1% resistor, R_{ISET} , to ground. When charging in constant-current mode, this pin serves to 1V. In all modes, the voltage on this pin can be used to measure the charge current using the following formula: $I_{BAT}=1000/R_{ISET}$
3、 9	GND	Ground.
4	VIN	Positive Input Supply Voltage.
5	BAT	Charge Current Output. Provides charge current to the battery and regulates the final float voltage to 4.2V. An internal precision resistor divider from this pin sets the float voltage.
6	STAT2	Open-Drain Charge Status Output. When the battery is charging, the STAT2 pin could be pulled High by an external pull high resistor. When the charge cycle is completed, the pin is pulled Low by an internal N-channel MOSFET.
7	STAT1	Open-Drain Charge Status Output. When the battery is charging, the STAT1 pin is pulled low by an internal N-channel MOSFET. When the charge cycle is completed, the pin could be pulled High by an external pull high resistor.

Function Block Diagram

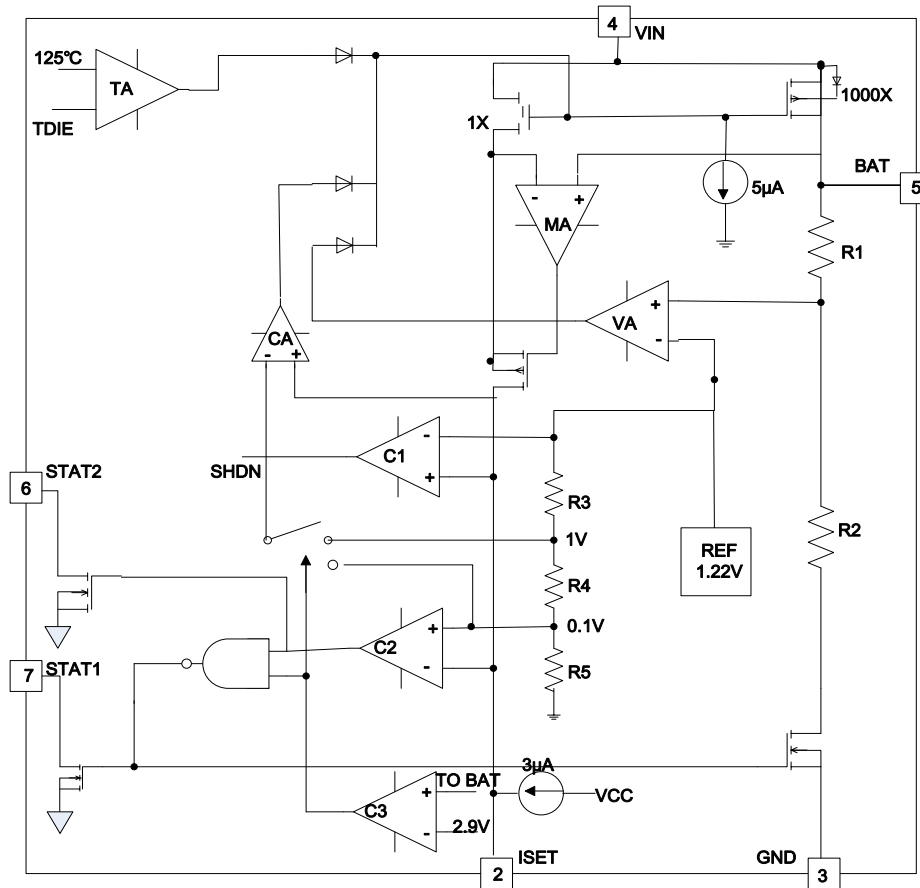

Absolute Maximum Ratings ^{Note1}

- ✧ Input to GND(VIN) ----- -0.3V to 8V
- ✧ Other Pin to GND ----- -0.3V to 6V
- ✧ BAT Short-circuit Duration ----- Continuous
- ✧ Maximum Junction Temperature ----- 125°C
- ✧ Operating Ambient Temperature Range (T_A) ----- -20°C to 85°C
- ✧ Storage Temperature- ----- -45°C to 165°C
- ✧ Maximum Soldering Temperature (at leads, 10 sec) ----- 260°C

Note1. Stresses beyond those listed under “Absolute Maximum Ratings” may cause permanent damage to the device. Exposure to absolute maximum rating conditions for extended periods may affect device reliability.

Thermal Information

- ✧ Maximum Power Dissipation (ESOP8, P_D , $T_A=25^\circ\text{C}$) ----- 2W
- ✧ Thermal Resistance (ESOP8, θ_{JA}) ----- 50°C/W

ESD Susceptibility

- ✧ HBM(Human Body Mode) ----- 2KV
 ✧ MM(Machine Mode) ----- 200V

Electrical Characteristics

($T_A = 25^\circ\text{C}$. $V_{IN} = 5\text{V}$, unless otherwise noted.)

SYMBOL	PARAMETER	CONDITIONS	MIN	TYP.	MAX	UNITS
V_{IN}	Adapter/USB Voltage Range		3.9	5	6	V
I_{IN}	Input Supply Current	Charge Mode, $R_{ISET}=10\text{K}$		300	1000	μA
		Standby Mode (Charge Terminated)		50	200	
V_{FLOAT}	Regulated Output (Float) Voltage	$0^\circ\text{C} \leq T_A \leq 85^\circ\text{C}$, $I_{BAT}=40\text{mA}$	4.158	4.2	4.242	V
I_{BAT}	BAT Pin Current	$R_{ISET}=10\text{K}$, Current Mode	80	100	120	mA
		$R_{ISET}=2\text{K}$, Current Mode	400	500	600	
		Standby Mode, $V_{BAT}=4.2\text{V}$ Sleep Mode, $V_{IN}=0\text{V}$	0		± 1	μA
V_{TRIKL}	Trickle Charge Threshold Voltage	$R_{ISET}=10\text{K}$, V_{BAT} Rising		2.9		V
V_{TRHYS}	Trickle Charge Hysteresis Voltage	$R_{ISET}=10\text{K}$		100		mV
I_{TRIKL}	Trickle charge current	$V_{BAT} < V_{TRIKL}$, $R_{ISET}=10\text{K}$		40		mA
		$V_{BAT} < V_{TRIKL}$, $R_{ISET}=2\text{K}$		200		
V_{UV}	V_{IN} Undervoltage Lockout Threshold	From V_{IN} Low to High	3.7	3.8	3.9	V
V_{UVHYS}	V_{IN} Undervoltage Lockout Hysteresis			300		mV
V_{ASD}	$V_{IN}-V_{BAT}$ Lockout Threshold Voltage			150		mV
V_{ISET}	ISET Pin Voltage	$R_{ISET}=10\text{K}$, Charge Mode		1		V
$V_{STAT1/2}$	STAT Pin Output Low Voltage	$I_{STAT1/2}=5\text{mA}$			0.5	V
$V_{STAT2/2}$	STAT Pin Weak Pull-Down Current	$V_{STAT1/2}=5\text{V}$			5	μA
ΔV_{RECHRG}	Recharge Battery Threshold Voltage	$V_{FLOAT}-V_{RECHRG}$	100	150	200	mV

Applications Information

The HX4056A is a single cell lithium-ion battery charger using a constant-current/constant-voltage algorithm. It can deliver up to 800mA of charge current with a final float voltage accuracy of $\pm 1\%$ (using a good thermal PCB layout). The HX4056A includes an internal P-channel power MOSFET and thermal regulation circuitry. No blocking diode or external current sense resistor is required; thus, the basic charger circuit requires only three external components. Furthermore, the HX4056A is capable of operating from a USB power source.

Normal Charge Cycle

A charge cycle begins when the voltage at the VIN pin rises above the UVLO threshold level and a 1% program resistor is connected from the ISET pin to ground or when a battery is connected to the charger output. If the BAT pin is less than 2.9V, the charger enters trickle charge mode.

When the BAT pin voltage rises above 2.9V, the charger enters constant-current mode, where the programmed charge current is supplied to the battery. When the BAT pin approaches the final float voltage (4.2V), the HX4056A enters constant-voltage mode and the charge current begins to decrease. When the charge current drops to 1/10 of the programmed value the charge cycle ends.

Programming Charge Current

The charge current is programmed using a single resistor from the ISET pin to ground. The battery charge current is 1000 times the current out of the ISET pin. The program resistor and the charge current are calculated using the following equations:

$$R_{ISET} = 1000 \div I_{BAT},$$

$$I_{BAT} = 1000 \div R_{ISET}$$

The charge current out of the BAT pin can be determined at any time by monitoring the ISET pin voltage using the following equation:

$$I_{BAT} = V_{ISET} \div R_{ISET} \times 1000$$

Charge Status Indicator (STAT1, STAT2)

The charge status output has two different states: strong pull-down (~5mA) and high impedance. The strong pull-down state indicates that the HX4056A is in a charge cycle. High impedance indicates that the charge cycle complete or the HX4056A is in under voltage lockout mode: either VIN is less than 100mV above the BAT pin voltage or insufficient voltage is applied to the VIN pin. A microprocessor can be used to distinguish between these two states.

Charge Stage	STAT1 Status	STAT2 Status
Charging	Low	High
Charge Complete	High	Low

Charge Termination

A charge cycle is terminated when the charge current falls to 1/10 the ISET rammed value after the final float voltage is reached. This condition is detected by using an internal, filtered comparator to monitor the ISET pin. When the ISET pin voltage falls below 100mV for longer than t_{TERM} (typically 1ms), charging is terminated. The charge current is latched off and the HX4056A enters standby mode, where the input supply current drops to 200 μ A. In this state, all loads on the BAT pin must be supplied by the battery. (Note: C/10 termination is disabled in trickle charging and thermal limiting modes).

Thermal Limit

An internal thermal feedback loop reduces the programmed charge current if the die temperature attempts to rise above a preset value of approximately 125°C. This feature protects the HX4056A from excessive temperature and allows the user to push the limits of the power handling capability of a given circuit board without risk of damaging the HX4056A. The charge current can be set according to typical (not worst-case) ambient temperature with the assurance that the charger will automatically reduce the current in worst-case conditions.

Automatic Recharge

The HX4056A constantly monitors the BAT pin voltage in standby mode. If this voltage drops below the 4.05V recharge threshold (V_{RECHRG}), another charge cycle begins and current is once again supplied to the battery. To manually restart a charge cycle when in standby mode, the input voltage must be removed and reapplied.

Power Dissipation

The conditions that cause the HX4056A to reduce charge current through thermal feedback can be approximated by considering the power dissipated in the IC. Nearly all of this power dissipation is generated by the internal MOSFET—this is calculated to be approximately:

$$P_D = (V_{IN} - V_{BAT}) \times I_{BAT}$$

Where P_D is the power dissipated, V_{IN} is the input supply voltage, V_{BAT} is the battery voltage and I_{BAT} is the charge current. The approximate ambient temperature at which the thermal feedback begins to protect the IC is:

$$T_A = 125^\circ\text{C} - P_D \theta_{JA}$$

$$T_A = 125^\circ\text{C} - (V_{IN} - V_{BAT}) \times I_{BAT} \times \theta_{JA}$$

VIN Bypass Capacitor

Many types of capacitors can be used for input bypassing; however, caution must be exercised when using multilayer ceramic capacitors. Because of the self-resonant and high Q characteristics of some types of ceramic capacitors, high voltage transients can be generated under some start-up conditions, such as connecting the charger input to a live power source. Adding a 1.5Ω resistor in series with an X5R ceramic capacitor will minimize start-up voltage transients.

Layout Considerations

- ✧ For the main current paths as indicated in bold lines, keep their traces short and wide.
- ✧ Put the input capacitor as close as possible to the device pins (VIN and GND).
- ✧ Connect all analog grounds to a command node and then connect the command node to the power ground behind the output capacitors.

Packaging Information

ESOP8

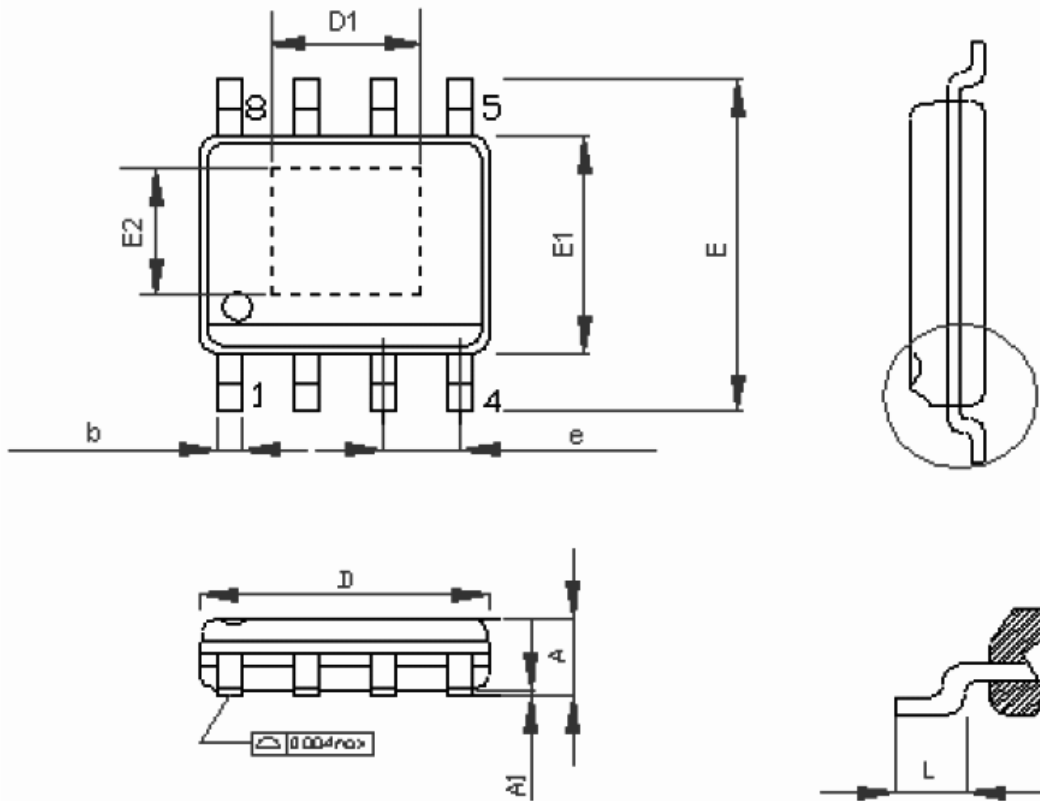

SYMBOLS	MILLIMETERS		INCHES	
	MIN.	MAX.	MIN.	MAX.
A	1.35	1.75	0.053	0.069
A1	0.05	0.25	0.002	0.010
D	4.90		0.193	
E1	3.90		0.153	
E	5.80	6.20	0.228	0.244
L	0.40	1.27	0.016	0.050
b	0.33	0.51	0.013	0.020
e	1.27		0.500	
D1	2.06		0.081	
E2	2.06		0.081	