



DATA SHEET

(DOC No. HX8227-A01-DS)

HX8227-A01
720CH TFT LCD Source Driver
with TCON
Version 05, November 2006

1. General Description

HX8227-A01 is a 720 channel output source driver with TCON (Timing Controller). The source driver receives 24-bit digital display data with single clock edge and generates corresponding 256 level gray scale voltage outputs to realize 16M colors display. Positive and negative polarity voltages can be alternately output from each channel in line (row) inversion or frame inversion driving methods.

2. Features

Source Driver

- 720 channel output source driver for TFT LCD panel
- Support 8-bit data input for 256 level gray scales
- Dynamic range: AVSS+0.2V ~ AVDD-0.2V
- Output voltage deviation: $\pm 20\text{mV}$.
- Driver power supply voltage (AVDD): 4.8 ~ 5.2V
- Bare chip with gold bumper for COG solution.

Embedded Timing Controller

- Support 480RGBx272, 480RGBx240, 240RGBx320, and 240RGBx240 resolutions
- Supporting 24-bit (8 bits x 3) parallel RGB and 8-bit serial RGB input interfaces
- Operation frequency: 15 MHz max in parallel RGB interface. 33MHz max in serial RGB interface.
- Support PAL decimation in 480RGBx240 or 240RGBx240 resolutions.
- Selectable line (row) inversion and frame inversion driving schemes.
- Provide the control timing of the source driver and the gate driver.
- Logic power supply voltage (DVDD): 2.25V ~ 3.6V

3. Block Diagram

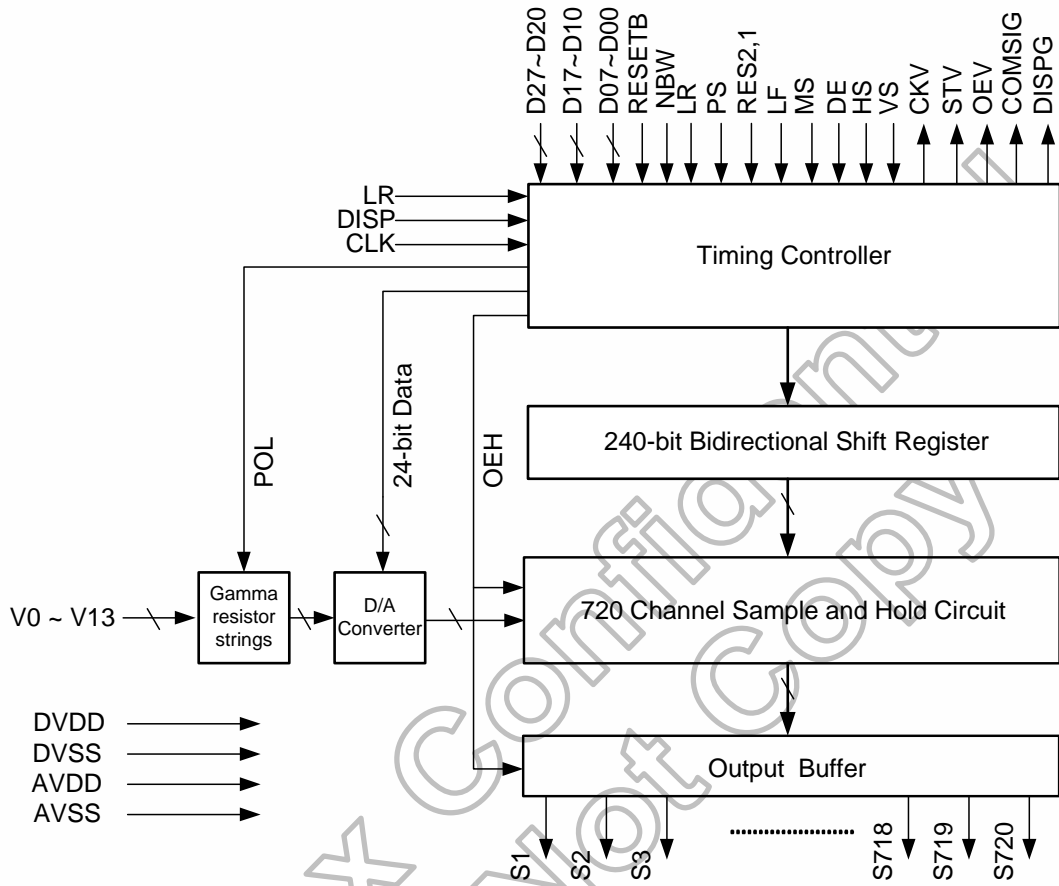

Figure 3. 1 Block diagram

4. PAD Location (IC Face View)

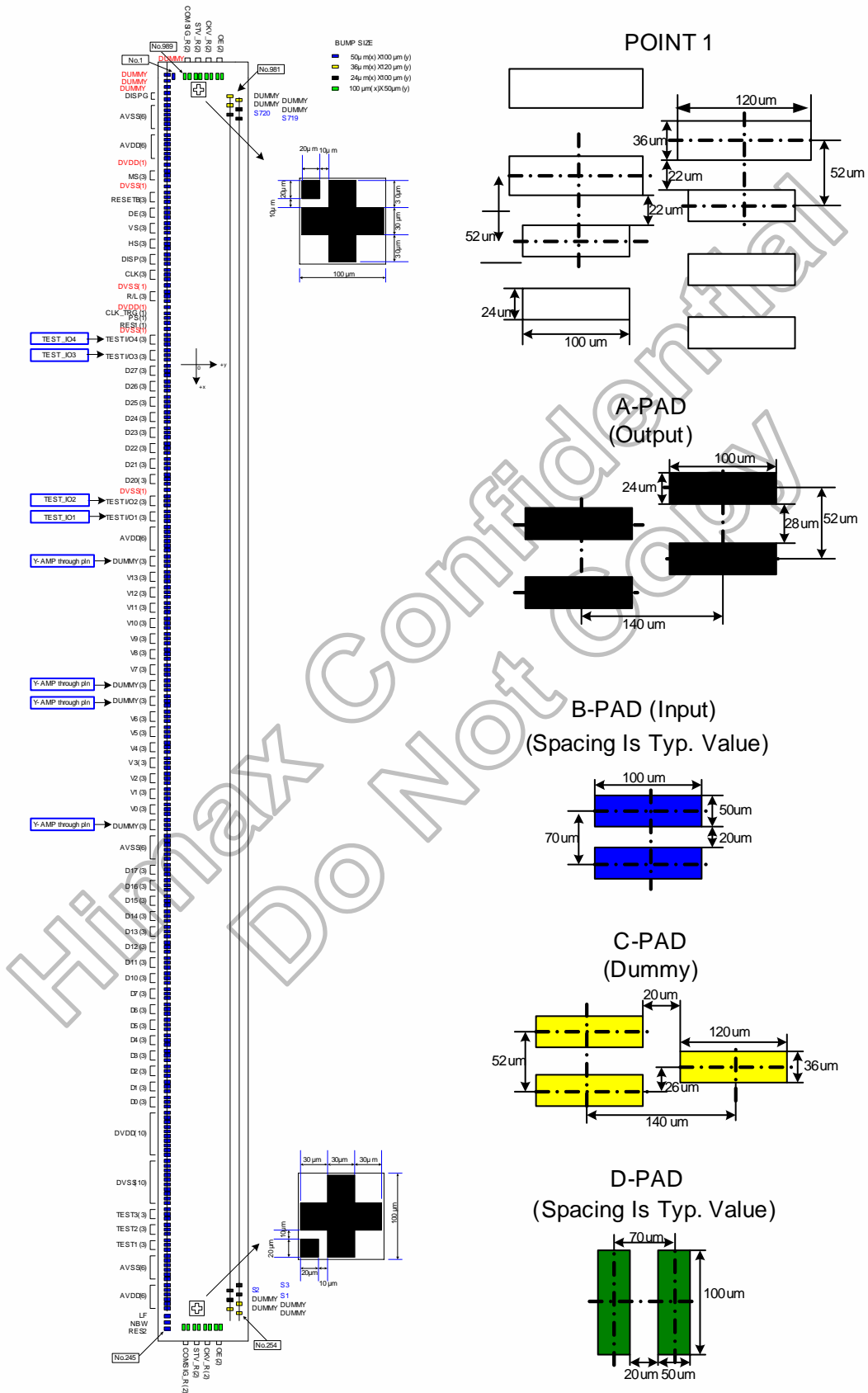

Figure 4. 1 Pad location

Chip Information

Items	Pad name	Size		Unit
		X	Y	
Chip size	-	19080	1286	um
Wafer thickness	-	400		
Bump size	Output pad (Type A)	24	100	
	Input pad (Type B)	50	100	
	Dummy pad (Type C)	36	120	
	D-pad (Type D)	50	100	

Table 4. 1

Alignment Mark Configuration and Coordinate

(1-a) (x, y) = (-9201.80, -344.00)

(1-b) (x, y) = (9201.80, -344.00)

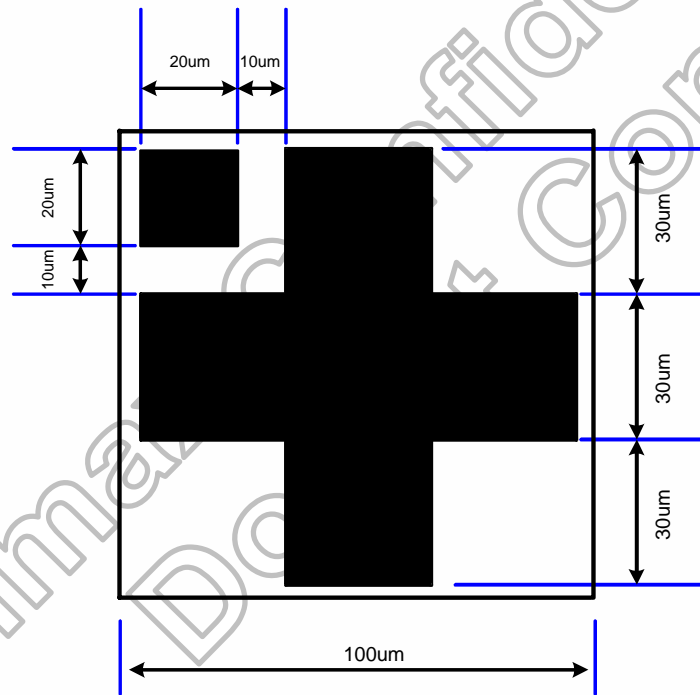

Figure 4. 2 Alignment mark configuration

Pad layout coordinate (Unit: μm)

No.	Name	X	Y	BUMP size	X Pitch	Y Pitch	No.	Name	X	Y	BUMP size	X Pitch	Y Pitch
1	DUMMY	-9422	-427	B	-25	-95	51	TEST I/O4	-5125	-522	B	70	0
2	DUMMY	-9447	-522	B	70	0	52	TEST I/O4	-5055	-522	B	70	0
3	DUMMY	-9377	-522	B	70	0	53	TEST I/O4	-4985	-522	B	80	0
4	DUMMY	-9307	-522	B	160	0	54	TEST I/O3	-4905	-522	B	70	0
5	DISPG	-9147	-522	B	70	0	55	TEST I/O3	-4835	-522	B	70	0
6	DISPG	-9077	-522	B	677	0	56	TEST I/O3	-4765	-522	B	75	0
7	AVSS	-8400	-522	B	70	0	57	D27	-4690	-522	B	70	0
8	AVSS	-8330	-522	B	70	0	58	D27	-4620	-522	B	70	0
9	AVSS	-8260	-522	B	70	0	59	D27	-4550	-522	B	80	0
10	AVSS	-8190	-522	B	70	0	60	D26	-4470	-522	B	70	0
11	AVSS	-8120	-522	B	70	0	61	D26	-4400	-522	B	70	0
12	AVSS	-8050	-522	B	100	0	62	D26	-4330	-522	B	80	0
13	AVDD	-7950	-522	B	70	0	63	D25	-4250	-522	B	70	0
14	AVDD	-7880	-522	B	70	0	64	D25	-4180	-522	B	70	0
15	AVDD	-7810	-522	B	70	0	65	D25	-4110	-522	B	80	0
16	AVDD	-7740	-522	B	70	0	66	D24	-4030	-522	B	70	0
17	AVDD	-7670	-522	B	70	0	67	D24	-3960	-522	B	70	0
18	AVDD	-7600	-522	B	100	0	68	D24	-3890	-522	B	80	0
19	DVDD	-7500	-522	B	80	0	69	D23	-3810	-522	B	70	0
20	MS	-7420	-522	B	70	0	70	D23	-3740	-522	B	70	0
21	MS	-7350	-522	B	70	0	71	D23	-3670	-522	B	80	0
22	MS	-7280	-522	B	70	0	72	D22	-3590	-522	B	70	0
23	DVSS	-7210	-522	B	80	0	73	D22	-3520	-522	B	70	0
24	RESETB	-7130	-522	B	70	0	74	D22	-3450	-522	B	80	0
25	RESETB	-7060	-522	B	70	0	75	D21	-3370	-522	B	70	0
26	RESETB	-6990	-522	B	80	0	76	D21	-3300	-522	B	70	0
27	DE	-6910	-522	B	70	0	77	D21	-3230	-522	B	80	0
28	DE	-6840	-522	B	70	0	78	D20	-3150	-522	B	70	0
29	DE	-6770	-522	B	80	0	79	D20	-3080	-522	B	70	0
30	VSC	-6690	-522	B	70	0	80	D20	-3010	-522	B	80	0
31	VSC	-6620	-522	B	70	0	81	DVSS	-2930	-522	B	85	0
32	VSC	-6550	-522	B	80	0	82	TEST I/O2	-2845	-522	B	70	0
33	HSC	-6470	-522	B	70	0	83	TEST I/O2	-2775	-522	B	70	0
34	HSC	-6400	-522	B	70	0	84	TEST I/O2	-2705	-522	B	80	0
35	HSC	-6330	-522	B	80	0	85	TEST I/O1	-2625	-522	B	70	0
36	DISP	-6250	-522	B	70	0	86	TEST I/O1	-2555	-522	B	70	0
37	DISP	-6180	-522	B	70	0	87	TEST I/O1	-2485	-522	B	95	0
38	DISP	-6110	-522	B	80	0	88	AVDD	-2390	-522	B	70	0
39	CLK	-6030	-522	B	70	0	89	AVDD	-2320	-522	B	70	0
40	CLK	-5960	-522	B	70	0	90	AVDD	-2250	-522	B	70	0
41	CLK	-5890	-522	B	80	0	91	AVDD	-2180	-522	B	70	0
42	DVSS	-5810	-522	B	80	0	92	AVDD	-2110	-522	B	70	0
43	R/L	-5730	-522	B	70	0	93	AVDD	-2040	-522	B	100	0
44	R/L	-5660	-522	B	70	0	94	DUMMY	-1940	-522	B	70	0
45	R/L	-5590	-522	B	80	0	95	DUMMY	-1870	-522	B	70	0
46	DVDD	-5510	-522	B	80	0	96	DUMMY	-1800	-522	B	80	0
47	CLK_TRG	-5430	-522	B	70	0	97	V13	-1720	-522	B	70	0
48	PS	-5360	-522	B	70	0	98	V13	-1650	-522	B	70	0
49	RES1	-5290	-522	B	80	0	99	V13	-1580	-522	B	80	0
50	DVSS	-5210	-522	B	85	0	100	V12	-1500	-522	B	70	0

No.	Name	X	Y	BUMP size	X Pitch	Y Pitch	No.	Name	X	Y	BUMP size	X Pitch	Y Pitch
101	V12	-1430	-522	B	70	0	151	AVSS	2250	-522	B	70	0
102	V12	-1360	-522	B	80	0	152	AVSS	2320	-522	B	70	0
103	V11	-1280	-522	B	70	0	153	AVSS	2390	-522	B	100	0
104	V11	-1210	-522	B	70	0	154	D17	2490	-522	B	70	0
105	V11	-1140	-522	B	80	0	155	D17	2560	-522	B	70	0
106	V10	-1060	-522	B	70	0	156	D17	2630	-522	B	80	0
107	V10	-990	-522	B	70	0	157	D16	2710	-522	B	70	0
108	V10	-920	-522	B	80	0	158	D16	2780	-522	B	70	0
109	V9	-840	-522	B	70	0	159	D16	2850	-522	B	80	0
110	V9	-770	-522	B	70	0	160	D15	2930	-522	B	70	0
111	V9	-700	-522	B	80	0	161	D15	3000	-522	B	70	0
112	V8	-620	-522	B	70	0	162	D15	3070	-522	B	80	0
113	V8	-550	-522	B	70	0	163	D14	3150	-522	B	70	0
114	V8	-480	-522	B	80	0	164	D14	3220	-522	B	70	0
115	V7	-400	-522	B	70	0	165	D14	3290	-522	B	80	0
116	V7	-330	-522	B	70	0	166	D13	3370	-522	B	70	0
117	V7	-260	-522	B	80	0	167	D13	3440	-522	B	70	0
118	DUMMY	-180	-522	B	70	0	168	D13	3510	-522	B	80	0
119	DUMMY	-110	-522	B	70	0	169	D12	3590	-522	B	70	0
120	DUMMY	-40	-522	B	80	0	170	D12	3660	-522	B	70	0
121	DUMMY	40	-522	B	70	0	171	D12	3730	-522	B	80	0
122	DUMMY	110	-522	B	70	0	172	D11	3810	-522	B	70	0
123	DUMMY	180	-522	B	80	0	173	D11	3880	-522	B	70	0
124	V6	260	-522	B	70	0	174	D11	3950	-522	B	80	0
125	V6	330	-522	B	70	0	175	D10	4030	-522	B	70	0
126	V6	400	-522	B	80	0	176	D10	4100	-522	B	70	0
127	V5	480	-522	B	70	0	177	D10	4170	-522	B	80	0
128	V5	550	-522	B	70	0	178	D7	4250	-522	B	70	0
129	V5	620	-522	B	80	0	179	D7	4320	-522	B	70	0
130	V4	700	-522	B	70	0	180	D7	4390	-522	B	80	0
131	V4	770	-522	B	70	0	181	D6	4470	-522	B	70	0
132	V4	840	-522	B	80	0	182	D6	4540	-522	B	70	0
133	V3	920	-522	B	70	0	183	D6	4610	-522	B	80	0
134	V3	990	-522	B	70	0	184	D5	4690	-522	B	70	0
135	V3	1060	-522	B	80	0	185	D5	4760	-522	B	70	0
136	V2	1140	-522	B	70	0	186	D5	4830	-522	B	80	0
137	V2	1210	-522	B	70	0	187	D4	4910	-522	B	70	0
138	V2	1280	-522	B	80	0	188	D4	4980	-522	B	70	0
139	V1	1360	-522	B	70	0	189	D4	5050	-522	B	80	0
140	V1	1430	-522	B	70	0	190	D3	5130	-522	B	70	0
141	V1	1500	-522	B	80	0	191	D3	5200	-522	B	70	0
142	V0	1580	-522	B	70	0	192	D3	5270	-522	B	80	0
143	V0	1650	-522	B	70	0	193	D2	5350	-522	B	70	0
144	V0	1720	-522	B	80	0	194	D2	5420	-522	B	70	0
145	DUMMY	1800	-522	B	70	0	195	D2	5490	-522	B	80	0
146	DUMMY	1870	-522	B	70	0	196	D1	5570	-522	B	70	0
147	DUMMY	1940	-522	B	100	0	197	D1	5640	-522	B	70	0
148	AVSS	2040	-522	B	70	0	198	D1	5710	-522	B	80	0
149	AVSS	2110	-522	B	70	0	199	D0	5790	-522	B	70	0
150	AVSS	2180	-522	B	70	0	200	D0	5860	-522	B	70	0

No.	Name	X	Y	BUMP size	X Pitch	Y Pitch	No.	Name	X	Y	BUMP size	X Pitch	Y Pitch
201	D0	5930	-522	B	100	0	251	CKV_R	9422	110	B	0	80
202	DVDD	6030	-522	B	70	0	252	OE	9422	190	B	0	70
203	DVDD	6100	-522	B	70	0	253	OE	9422	260	B		
204	DVDD	6170	-522	B	70	0	254	DUMMY	9451	512	C	-26	-140
205	DVDD	6240	-522	B	70	0	255	DUMMY	9425	372	C	-26	140
206	DVDD	6310	-522	B	70	0	256	DUMMY	9399	512	C	-26	-130
207	DVDD	6380	-522	B	70	0	257	DUMMY	9373	382	A	-26	140
208	DVDD	6450	-522	B	70	0	258	S1	9347	522	A	-26	-140
209	DVDD	6520	-522	B	70	0	259	S2	9321	382	A	-26	140
210	DVDD	6590	-522	B	70	0	260	S3	9295	522	A	-26	-140
211	DVDD	6660	-522	B	200	0	261	S4	9269	382	A	-26	140
212	DVSS	6860	-522	B	70	0	262	S5	9243	522	A	-26	-140
213	DVSS	6930	-522	B	70	0	263	S6	9217	382	A	-26	140
214	DVSS	7000	-522	B	70	0	264	S7	9191	522	A	-26	-140
215	DVSS	7070	-522	B	70	0	265	S8	9165	382	A	-26	140
216	DVSS	7140	-522	B	70	0	266	S9	9139	522	A	-26	-140
217	DVSS	7210	-522	B	70	0	267	S10	9113	382	A	-26	140
218	DVSS	7280	-522	B	70	0	268	S11	9087	522	A	-26	-140
219	DVSS	7350	-522	B	70	0	269	S12	9061	382	A	-26	140
220	DVSS	7420	-522	B	70	0	270	S13	9035	522	A	-26	-140
221	DVSS	7490	-522	B	200	0	271	S14	9009	382	A	-26	140
222	TEST3	7690	-522	B	70	0	272	S15	8983	522	A	-26	-140
223	TEST3	7760	-522	B	70	0	273	S16	8957	382	A	-26	140
224	TEST3	7830	-522	B	80	0	274	S17	8931	522	A	-26	-140
225	TEST2	7910	-522	B	70	0	275	S18	8905	382	A	-26	140
226	TEST2	7980	-522	B	70	0	276	S19	8879	522	A	-26	-140
227	TEST2	8050	-522	B	80	0	277	S20	8853	382	A	-26	140
228	TEST1	8130	-522	B	70	0	278	S21	8827	522	A	-26	-140
229	TEST1	8200	-522	B	70	0	279	S22	8801	382	A	-26	140
230	TEST1	8270	-522	B	100	0	280	S23	8775	522	A	-26	-140
231	AVSS	8370	-522	B	70	0	281	S24	8749	382	A	-26	140
232	AVSS	8440	-522	B	70	0	282	S25	8723	522	A	-26	-140
233	AVSS	8510	-522	B	70	0	283	S26	8697	382	A	-26	140
234	AVSS	8580	-522	B	70	0	284	S27	8671	522	A	-26	-140
235	AVSS	8650	-522	B	70	0	285	S28	8645	382	A	-26	140
236	AVSS	8720	-522	B	100	0	286	S29	8619	522	A	-26	-140
237	AVDD	8820	-522	B	70	0	287	S30	8593	382	A	-26	140
238	AVDD	8890	-522	B	70	0	288	S31	8567	522	A	-26	-140
239	AVDD	8960	-522	B	70	0	289	S32	8541	382	A	-26	140
240	AVDD	9030	-522	B	70	0	290	S33	8515	522	A	-26	-140
241	AVDD	9100	-522	B	70	0	291	S34	8489	382	A	-26	140
242	AVDD	9170	-522	B	137	0	292	S35	8463	522	A	-26	-140
243	LF	9307	-522	B	70	0	293	S36	8437	382	A	-26	140
244	NBW	9377	-522	B	70	0	294	S37	8411	522	A	-26	-140
245	RES2	9447	-522	B			295	S38	8385	382	A	-26	140
246	COMSIG_R	9422	-260	B	0	70	296	S39	8359	522	A	-26	-140
247	COMSIG_R	9422	-190	B	0	80	297	S40	8333	382	A	-26	140
248	STV_R	9422	-110	B	0	70	298	S41	8307	522	A	-26	-140
249	STV_R	9422	-40	B	0	80	299	S42	8281	382	A	-26	140
250	CKV_R	9422	40	B	0	70	300	S43	8255	522	A	-26	-140

No.	Name	X	Y	BUMP size	X Pitch	Y Pitch	No.	Name	X	Y	BUMP size	X Pitch	Y Pitch
301	S44	8229	382	A	-26	140	351	S94	6929	382	A	-26	140
302	S45	8203	522	A	-26	-140	352	S95	6903	522	A	-26	-140
303	S46	8177	382	A	-26	140	353	S96	6877	382	A	-26	140
304	S47	8151	522	A	-26	-140	354	S97	6851	522	A	-26	-140
305	S48	8125	382	A	-26	140	355	S98	6825	382	A	-26	140
306	S49	8099	522	A	-26	-140	356	S99	6799	522	A	-26	-140
307	S50	8073	382	A	-26	140	357	S100	6773	382	A	-26	140
308	S51	8047	522	A	-26	-140	358	S101	6747	522	A	-26	-140
309	S52	8021	382	A	-26	140	359	S102	6721	382	A	-26	140
310	S53	7995	522	A	-26	-140	360	S103	6695	522	A	-26	-140
311	S54	7969	382	A	-26	140	361	S104	6669	382	A	-26	140
312	S55	7943	522	A	-26	-140	362	S105	6643	522	A	-26	-140
313	S56	7917	382	A	-26	140	363	S106	6617	382	A	-26	140
314	S57	7891	522	A	-26	-140	364	S107	6591	522	A	-26	-140
315	S58	7865	382	A	-26	140	365	S108	6565	382	A	-26	140
316	S59	7839	522	A	-26	-140	366	S109	6539	522	A	-26	-140
317	S60	7813	382	A	-26	140	367	S110	6513	382	A	-26	140
318	S61	7787	522	A	-26	-140	368	S111	6487	522	A	-26	-140
319	S62	7761	382	A	-26	140	369	S112	6461	382	A	-26	140
320	S63	7735	522	A	-26	-140	370	S113	6435	522	A	-26	-140
321	S64	7709	382	A	-26	140	371	S114	6409	382	A	-26	140
322	S65	7683	522	A	-26	-140	372	S115	6383	522	A	-26	-140
323	S66	7657	382	A	-26	140	373	S116	6357	382	A	-26	140
324	S67	7631	522	A	-26	-140	374	S117	6331	522	A	-26	-140
325	S68	7605	382	A	-26	140	375	S118	6305	382	A	-26	140
326	S69	7579	522	A	-26	-140	376	S119	6279	522	A	-26	-140
327	S70	7553	382	A	-26	140	377	S120	6253	382	A	-26	140
328	S71	7527	522	A	-26	-140	378	S121	6227	522	A	-26	-140
329	S72	7501	382	A	-26	140	379	S122	6201	382	A	-26	140
330	S73	7475	522	A	-26	-140	380	S123	6175	522	A	-26	-140
331	S74	7449	382	A	-26	140	381	S124	6149	382	A	-26	140
332	S75	7423	522	A	-26	-140	382	S125	6123	522	A	-26	-140
333	S76	7397	382	A	-26	140	383	S126	6097	382	A	-26	140
334	S77	7371	522	A	-26	-140	384	S127	6071	522	A	-26	-140
335	S78	7345	382	A	-26	140	385	S128	6045	382	A	-26	140
336	S79	7319	522	A	-26	-140	386	S129	6019	522	A	-26	-140
337	S80	7293	382	A	-26	140	387	S130	5993	382	A	-26	140
338	S81	7267	522	A	-26	-140	388	S131	5967	522	A	-26	-140
339	S82	7241	382	A	-26	140	389	S132	5941	382	A	-26	140
340	S83	7215	522	A	-26	-140	390	S133	5915	522	A	-26	-140
341	S84	7189	382	A	-26	140	391	S134	5889	382	A	-26	140
342	S85	7163	522	A	-26	-140	392	S135	5863	522	A	-26	-140
343	S86	7137	382	A	-26	140	393	S136	5837	382	A	-26	140
344	S87	7111	522	A	-26	-140	394	S137	5811	522	A	-26	-140
345	S88	7085	382	A	-26	140	395	S138	5785	382	A	-26	140
346	S89	7059	522	A	-26	-140	396	S139	5759	522	A	-26	-140
347	S90	7033	382	A	-26	140	397	S140	5733	382	A	-26	140
348	S91	7007	522	A	-26	-140	398	S141	5707	522	A	-26	-140
349	S92	6981	382	A	-26	140	399	S142	5681	382	A	-26	140
350	S93	6955	522	A	-26	-140	400	S143	5655	522	A	-26	-140

No.	Name	X	Y	BUMP size	X Pitch	Y Pitch	No.	Name	X	Y	BUMP size	X Pitch	Y Pitch
401	S144	5629	382	A	-26	140	451	S194	4329	382	A	-26	140
402	S145	5603	522	A	-26	-140	452	S195	4303	522	A	-26	-140
403	S146	5577	382	A	-26	140	453	S196	4277	382	A	-26	140
404	S147	5551	522	A	-26	-140	454	S197	4251	522	A	-26	-140
405	S148	5525	382	A	-26	140	455	S198	4225	382	A	-26	140
406	S149	5499	522	A	-26	-140	456	S199	4199	522	A	-26	-140
407	S150	5473	382	A	-26	140	457	S200	4173	382	A	-26	140
408	S151	5447	522	A	-26	-140	458	S201	4147	522	A	-26	-140
409	S152	5421	382	A	-26	140	459	S202	4121	382	A	-26	140
410	S153	5395	522	A	-26	-140	460	S203	4095	522	A	-26	-140
411	S154	5369	382	A	-26	140	461	S204	4069	382	A	-26	140
412	S155	5343	522	A	-26	-140	462	S205	4043	522	A	-26	-140
413	S156	5317	382	A	-26	140	463	S206	4017	382	A	-26	140
414	S157	5291	522	A	-26	-140	464	S207	3991	522	A	-26	-140
415	S158	5265	382	A	-26	140	465	S208	3965	382	A	-26	140
416	S159	5239	522	A	-26	-140	466	S209	3939	522	A	-26	-140
417	S160	5213	382	A	-26	140	467	S210	3913	382	A	-26	140
418	S161	5187	522	A	-26	-140	468	S211	3887	522	A	-26	-140
419	S162	5161	382	A	-26	140	469	S212	3861	382	A	-26	140
420	S163	5135	522	A	-26	-140	470	S213	3835	522	A	-26	-140
421	S164	5109	382	A	-26	140	471	S214	3809	382	A	-26	140
422	S165	5083	522	A	-26	-140	472	S215	3783	522	A	-26	-140
423	S166	5057	382	A	-26	140	473	S216	3757	382	A	-26	140
424	S167	5031	522	A	-26	-140	474	S217	3731	522	A	-26	-140
425	S168	5005	382	A	-26	140	475	S218	3705	382	A	-26	140
426	S169	4979	522	A	-26	-140	476	S219	3679	522	A	-26	-140
427	S170	4953	382	A	-26	140	477	S220	3653	382	A	-26	140
428	S171	4927	522	A	-26	-140	478	S221	3627	522	A	-26	-140
429	S172	4901	382	A	-26	140	479	S222	3601	382	A	-26	140
430	S173	4875	522	A	-26	-140	480	S223	3575	522	A	-26	-140
431	S174	4849	382	A	-26	140	481	S224	3549	382	A	-26	140
432	S175	4823	522	A	-26	-140	482	S225	3523	522	A	-26	-140
433	S176	4797	382	A	-26	140	483	S226	3497	382	A	-26	140
434	S177	4771	522	A	-26	-140	484	S227	3471	522	A	-26	-140
435	S178	4745	382	A	-26	140	485	S228	3445	382	A	-26	140
436	S179	4719	522	A	-26	-140	486	S229	3419	522	A	-26	-140
437	S180	4693	382	A	-26	140	487	S230	3393	382	A	-26	140
438	S181	4667	522	A	-26	-140	488	S231	3367	522	A	-26	-140
439	S182	4641	382	A	-26	140	489	S232	3341	382	A	-26	140
440	S183	4615	522	A	-26	-140	490	S233	3315	522	A	-26	-140
441	S184	4589	382	A	-26	140	491	S234	3289	382	A	-26	140
442	S185	4563	522	A	-26	-140	492	S235	3263	522	A	-26	-140
443	S186	4537	382	A	-26	140	493	S236	3237	382	A	-26	140
444	S187	4511	522	A	-26	-140	494	S237	3211	522	A	-26	-140
445	S188	4485	382	A	-26	140	495	S238	3185	382	A	-26	140
446	S189	4459	522	A	-26	-140	496	S239	3159	522	A	-26	-140
447	S190	4433	382	A	-26	140	497	S240	3133	382	A	-26	140
448	S191	4407	522	A	-26	-140	498	S241	3107	522	A	-26	-140
449	S192	4381	382	A	-26	140	499	S242	3081	382	A	-26	140
450	S193	4355	522	A	-26	-140	500	S243	3055	522	A	-26	-140

No.	Name	X	Y	BUMP size	X Pitch	Y Pitch	No.	Name	X	Y	BUMP size	X Pitch	Y Pitch
501	S244	3029	382	A	-26	140	551	S294	1729	382	A	-26	140
502	S245	3003	522	A	-26	-140	552	S295	1703	522	A	-26	-140
503	S246	2977	382	A	-26	140	553	S296	1677	382	A	-26	140
504	S247	2951	522	A	-26	-140	554	S297	1651	522	A	-26	-140
505	S248	2925	382	A	-26	140	555	S298	1625	382	A	-26	140
506	S249	2899	522	A	-26	-140	556	S299	1599	522	A	-26	-140
507	S250	2873	382	A	-26	140	557	S300	1573	382	A	-26	140
508	S251	2847	522	A	-26	-140	558	S301	1547	522	A	-26	-140
509	S252	2821	382	A	-26	140	559	S302	1521	382	A	-26	140
510	S253	2795	522	A	-26	-140	560	S303	1495	522	A	-26	-140
511	S254	2769	382	A	-26	140	561	S304	1469	382	A	-26	140
512	S255	2743	522	A	-26	-140	562	S305	1443	522	A	-26	-140
513	S256	2717	382	A	-26	140	563	S306	1417	382	A	-26	140
514	S257	2691	522	A	-26	-140	564	S307	1391	522	A	-26	-140
515	S258	2665	382	A	-26	140	565	S308	1365	382	A	-26	140
516	S259	2639	522	A	-26	-140	566	S309	1339	522	A	-26	-140
517	S260	2613	382	A	-26	140	567	S310	1313	382	A	-26	140
518	S261	2587	522	A	-26	-140	568	S311	1287	522	A	-26	-140
519	S262	2561	382	A	-26	140	569	S312	1261	382	A	-26	140
520	S263	2535	522	A	-26	-140	570	S313	1235	522	A	-26	-140
521	S264	2509	382	A	-26	140	571	S314	1209	382	A	-26	140
522	S265	2483	522	A	-26	-140	572	S315	1183	522	A	-26	-140
523	S266	2457	382	A	-26	140	573	S316	1157	382	A	-26	140
524	S267	2431	522	A	-26	-140	574	S317	1131	522	A	-26	-140
525	S268	2405	382	A	-26	140	575	S318	1105	382	A	-26	140
526	S269	2379	522	A	-26	-140	576	S319	1079	522	A	-26	-140
527	S270	2353	382	A	-26	140	577	S320	1053	382	A	-26	140
528	S271	2327	522	A	-26	-140	578	S321	1027	522	A	-26	-140
529	S272	2301	382	A	-26	140	579	S322	1001	382	A	-26	140
530	S273	2275	522	A	-26	-140	580	S323	975	522	A	-26	-140
531	S274	2249	382	A	-26	140	581	S324	949	382	A	-26	140
532	S275	2223	522	A	-26	-140	582	S325	923	522	A	-26	-140
533	S276	2197	382	A	-26	140	583	S326	897	382	A	-26	140
534	S277	2171	522	A	-26	-140	584	S327	871	522	A	-26	-140
535	S278	2145	382	A	-26	140	585	S328	845	382	A	-26	140
536	S279	2119	522	A	-26	-140	586	S329	819	522	A	-26	-140
537	S280	2093	382	A	-26	140	587	S330	793	382	A	-26	140
538	S281	2067	522	A	-26	-140	588	S331	767	522	A	-26	-140
539	S282	2041	382	A	-26	140	589	S332	741	382	A	-26	140
540	S283	2015	522	A	-26	-140	590	S333	715	522	A	-26	-140
541	S284	1989	382	A	-26	140	591	S334	689	382	A	-26	140
542	S285	1963	522	A	-26	-140	592	S335	663	522	A	-26	-140
543	S286	1937	382	A	-26	140	593	S336	637	382	A	-26	140
544	S287	1911	522	A	-26	-140	594	S337	611	522	A	-26	-140
545	S288	1885	382	A	-26	140	595	S338	585	382	A	-26	140
546	S289	1859	522	A	-26	-140	596	S339	559	522	A	-26	-140
547	S290	1833	382	A	-26	140	597	S340	533	382	A	-26	140
548	S291	1807	522	A	-26	-140	598	S341	507	522	A	-26	-140
549	S292	1781	382	A	-26	140	599	S342	481	382	A	-26	140
550	S293	1755	522	A	-26	-140	600	S343	455	522	A	-26	-140

No.	Name	X	Y	BUMP size	X Pitch	Y Pitch	No.	Name	X	Y	BUMP size	X Pitch	Y Pitch
601	S344	429	382	A	-26	140	651	S394	-871	382	A	-26	140
602	S345	403	522	A	-26	-140	652	S395	-897	522	A	-26	-140
603	S346	377	382	A	-26	140	653	S396	-923	382	A	-26	140
604	S347	351	522	A	-26	-140	654	S397	-949	522	A	-26	-140
605	S348	325	382	A	-26	140	655	S398	-975	382	A	-26	140
606	S349	299	522	A	-26	-140	656	S399	-1001	522	A	-26	-140
607	S350	273	382	A	-26	140	657	S400	-1027	382	A	-26	140
608	S351	247	522	A	-26	-140	658	S401	-1053	522	A	-26	-140
609	S352	221	382	A	-26	140	659	S402	-1079	382	A	-26	140
610	S353	195	522	A	-26	-140	660	S403	-1105	522	A	-26	-140
611	S354	169	382	A	-26	140	661	S404	-1131	382	A	-26	140
612	S355	143	522	A	-26	-140	662	S405	-1157	522	A	-26	-140
613	S356	117	382	A	-26	140	663	S406	-1183	382	A	-26	140
614	S357	91	522	A	-26	-140	664	S407	-1209	522	A	-26	-140
615	S358	65	382	A	-26	140	665	S408	-1235	382	A	-26	140
616	S359	39	522	A	-26	-140	666	S409	-1261	522	A	-26	-140
617	S360	13	382	A	-26	140	667	S410	-1287	382	A	-26	140
618	S361	-13	522	A	-26	-140	668	S411	-1313	522	A	-26	-140
619	S362	-39	382	A	-26	140	669	S412	-1339	382	A	-26	140
620	S363	-65	522	A	-26	-140	670	S413	-1365	522	A	-26	-140
621	S364	-91	382	A	-26	140	671	S414	-1391	382	A	-26	140
622	S365	-117	522	A	-26	-140	672	S415	-1417	522	A	-26	-140
623	S366	-143	382	A	-26	140	673	S416	-1443	382	A	-26	140
624	S367	-169	522	A	-26	-140	674	S417	-1469	522	A	-26	-140
625	S368	-195	382	A	-26	140	675	S418	-1495	382	A	-26	140
626	S369	-221	522	A	-26	-140	676	S419	-1521	522	A	-26	-140
627	S370	-247	382	A	-26	140	677	S420	-1547	382	A	-26	140
628	S371	-273	522	A	-26	-140	678	S421	-1573	522	A	-26	-140
629	S372	-299	382	A	-26	140	679	S422	-1599	382	A	-26	140
630	S373	-325	522	A	-26	-140	680	S423	-1625	522	A	-26	-140
631	S374	-351	382	A	-26	140	681	S424	-1651	382	A	-26	140
632	S375	-377	522	A	-26	-140	682	S425	-1677	522	A	-26	-140
633	S376	-403	382	A	-26	140	683	S426	-1703	382	A	-26	140
634	S377	-429	522	A	-26	-140	684	S427	-1729	522	A	-26	-140
635	S378	-455	382	A	-26	140	685	S428	-1755	382	A	-26	140
636	S379	-481	522	A	-26	-140	686	S429	-1781	522	A	-26	-140
637	S380	-507	382	A	-26	140	687	S430	-1807	382	A	-26	140
638	S381	-533	522	A	-26	-140	688	S431	-1833	522	A	-26	-140
639	S382	-559	382	A	-26	140	689	S432	-1859	382	A	-26	140
640	S383	-585	522	A	-26	-140	690	S433	-1885	522	A	-26	-140
641	S384	-611	382	A	-26	140	691	S434	-1911	382	A	-26	140
642	S385	-637	522	A	-26	-140	692	S435	-1937	522	A	-26	-140
643	S386	-663	382	A	-26	140	693	S436	-1963	382	A	-26	140
644	S387	-689	522	A	-26	-140	694	S437	-1989	522	A	-26	-140
645	S388	-715	382	A	-26	140	695	S438	-2015	382	A	-26	140
646	S389	-741	522	A	-26	-140	696	S439	-2041	522	A	-26	-140
647	S390	-767	382	A	-26	140	697	S440	-2067	382	A	-26	140
648	S391	-793	522	A	-26	-140	698	S441	-2093	522	A	-26	-140
649	S392	-819	382	A	-26	140	699	S442	-2119	382	A	-26	140
650	S393	-845	522	A	-26	-140	700	S443	-2145	522	A	-26	-140

No.	Name	X	Y	BUMP size	X Pitch	Y Pitch	No.	Name	X	Y	BUMP size	X Pitch	Y Pitch
701	S444	-2171	382	A	-26	140	751	S494	-3471	382	A	-26	140
702	S445	-2197	522	A	-26	-140	752	S495	-3497	522	A	-26	-140
703	S446	-2223	382	A	-26	140	753	S496	-3523	382	A	-26	140
704	S447	-2249	522	A	-26	-140	754	S497	-3549	522	A	-26	-140
705	S448	-2275	382	A	-26	140	755	S498	-3575	382	A	-26	140
706	S449	-2301	522	A	-26	-140	756	S499	-3601	522	A	-26	-140
707	S450	-2327	382	A	-26	140	757	S500	-3627	382	A	-26	140
708	S451	-2353	522	A	-26	-140	758	S501	-3653	522	A	-26	-140
709	S452	-2379	382	A	-26	140	759	S502	-3679	382	A	-26	140
710	S453	-2405	522	A	-26	-140	760	S503	-3705	522	A	-26	-140
711	S454	-2431	382	A	-26	140	761	S504	-3731	382	A	-26	140
712	S455	-2457	522	A	-26	-140	762	S505	-3757	522	A	-26	-140
713	S456	-2483	382	A	-26	140	763	S506	-3783	382	A	-26	140
714	S457	-2509	522	A	-26	-140	764	S507	-3809	522	A	-26	-140
715	S458	-2535	382	A	-26	140	765	S508	-3835	382	A	-26	140
716	S459	-2561	522	A	-26	-140	766	S509	-3861	522	A	-26	-140
717	S460	-2587	382	A	-26	140	767	S510	-3887	382	A	-26	140
718	S461	-2613	522	A	-26	-140	768	S511	-3913	522	A	-26	-140
719	S462	-2639	382	A	-26	140	769	S512	-3939	382	A	-26	140
720	S463	-2665	522	A	-26	-140	770	S513	-3965	522	A	-26	-140
721	S464	-2691	382	A	-26	140	771	S514	-3991	382	A	-26	140
722	S465	-2717	522	A	-26	-140	772	S515	-4017	522	A	-26	-140
723	S466	-2743	382	A	-26	140	773	S516	-4043	382	A	-26	140
724	S467	-2769	522	A	-26	-140	774	S517	-4069	522	A	-26	-140
725	S468	-2795	382	A	-26	140	775	S518	-4095	382	A	-26	140
726	S469	-2821	522	A	-26	-140	776	S519	-4121	522	A	-26	-140
727	S470	-2847	382	A	-26	140	777	S520	-4147	382	A	-26	140
728	S471	-2873	522	A	-26	-140	778	S521	-4173	522	A	-26	-140
729	S472	-2899	382	A	-26	140	779	S522	-4199	382	A	-26	140
730	S473	-2925	522	A	-26	-140	780	S523	-4225	522	A	-26	-140
731	S474	-2951	382	A	-26	140	781	S524	-4251	382	A	-26	140
732	S475	-2977	522	A	-26	-140	782	S525	-4277	522	A	-26	-140
733	S476	-3003	382	A	-26	140	783	S526	-4303	382	A	-26	140
734	S477	-3029	522	A	-26	-140	784	S527	-4329	522	A	-26	-140
735	S478	-3055	382	A	-26	140	785	S528	-4355	382	A	-26	140
736	S479	-3081	522	A	-26	-140	786	S529	-4381	522	A	-26	-140
737	S480	-3107	382	A	-26	140	787	S530	-4407	382	A	-26	140
738	S481	-3133	522	A	-26	-140	788	S531	-4433	522	A	-26	-140
739	S482	-3159	382	A	-26	140	789	S532	-4459	382	A	-26	140
740	S483	-3185	522	A	-26	-140	790	S533	-4485	522	A	-26	-140
741	S484	-3211	382	A	-26	140	791	S534	-4511	382	A	-26	140
742	S485	-3237	522	A	-26	-140	792	S535	-4537	522	A	-26	-140
743	S486	-3263	382	A	-26	140	793	S536	-4563	382	A	-26	140
744	S487	-3289	522	A	-26	-140	794	S537	-4589	522	A	-26	-140
745	S488	-3315	382	A	-26	140	795	S538	-4615	382	A	-26	140
746	S489	-3341	522	A	-26	-140	796	S539	-4641	522	A	-26	-140
747	S490	-3367	382	A	-26	140	797	S540	-4667	382	A	-26	140
748	S491	-3393	522	A	-26	-140	798	S541	-4693	522	A	-26	-140
749	S492	-3419	382	A	-26	140	799	S542	-4719	382	A	-26	140
750	S493	-3445	522	A	-26	-140	800	S543	-4745	522	A	-26	-140

No.	Name	X	Y	BUMP size	X Pitch	Y Pitch	No.	Name	X	Y	BUMP size	X Pitch	Y Pitch
801	S544	-4771	382	A	-26	140	851	S594	-6071	382	A	-26	140
802	S545	-4797	522	A	-26	-140	852	S595	-6097	522	A	-26	-140
803	S546	-4823	382	A	-26	140	853	S596	-6123	382	A	-26	140
804	S547	-4849	522	A	-26	-140	854	S597	-6149	522	A	-26	-140
805	S548	-4875	382	A	-26	140	855	S598	-6175	382	A	-26	140
806	S549	-4901	522	A	-26	-140	856	S599	-6201	522	A	-26	-140
807	S550	-4927	382	A	-26	140	857	S600	-6227	382	A	-26	140
808	S551	-4953	522	A	-26	-140	858	S601	-6253	522	A	-26	-140
809	S552	-4979	382	A	-26	140	859	S602	-6279	382	A	-26	140
810	S553	-5005	522	A	-26	-140	860	S603	-6305	522	A	-26	-140
811	S554	-5031	382	A	-26	140	861	S604	-6331	382	A	-26	140
812	S555	-5057	522	A	-26	-140	862	S605	-6357	522	A	-26	-140
813	S556	-5083	382	A	-26	140	863	S606	-6383	382	A	-26	140
814	S557	-5109	522	A	-26	-140	864	S607	-6409	522	A	-26	-140
815	S558	-5135	382	A	-26	140	865	S608	-6435	382	A	-26	140
816	S559	-5161	522	A	-26	-140	866	S609	-6461	522	A	-26	-140
817	S560	-5187	382	A	-26	140	867	S610	-6487	382	A	-26	140
818	S561	-5213	522	A	-26	-140	868	S611	-6513	522	A	-26	-140
819	S562	-5239	382	A	-26	140	869	S612	-6539	382	A	-26	140
820	S563	-5265	522	A	-26	-140	870	S613	-6565	522	A	-26	-140
821	S564	-5291	382	A	-26	140	871	S614	-6591	382	A	-26	140
822	S565	-5317	522	A	-26	-140	872	S615	-6617	522	A	-26	-140
823	S566	-5343	382	A	-26	140	873	S616	-6643	382	A	-26	140
824	S567	-5369	522	A	-26	-140	874	S617	-6669	522	A	-26	-140
825	S568	-5395	382	A	-26	140	875	S618	-6695	382	A	-26	140
826	S569	-5421	522	A	-26	-140	876	S619	-6721	522	A	-26	-140
827	S570	-5447	382	A	-26	140	877	S620	-6747	382	A	-26	140
828	S571	-5473	522	A	-26	-140	878	S621	-6773	522	A	-26	-140
829	S572	-5499	382	A	-26	140	879	S622	-6799	382	A	-26	140
830	S573	-5525	522	A	-26	-140	880	S623	-6825	522	A	-26	-140
831	S574	-5551	382	A	-26	140	881	S624	-6851	382	A	-26	140
832	S575	-5577	522	A	-26	-140	882	S625	-6877	522	A	-26	-140
833	S576	-5603	382	A	-26	140	883	S626	-6903	382	A	-26	140
834	S577	-5629	522	A	-26	-140	884	S627	-6929	522	A	-26	-140
835	S578	-5655	382	A	-26	140	885	S628	-6955	382	A	-26	140
836	S579	-5681	522	A	-26	-140	886	S629	-6981	522	A	-26	-140
837	S580	-5707	382	A	-26	140	887	S630	-7007	382	A	-26	140
838	S581	-5733	522	A	-26	-140	888	S631	-7033	522	A	-26	-140
839	S582	-5759	382	A	-26	140	889	S632	-7059	382	A	-26	140
840	S583	-5785	522	A	-26	-140	890	S633	-7085	522	A	-26	-140
841	S584	-5811	382	A	-26	140	891	S634	-7111	382	A	-26	140
842	S585	-5837	522	A	-26	-140	892	S635	-7137	522	A	-26	-140
843	S586	-5863	382	A	-26	140	893	S636	-7163	382	A	-26	140
844	S587	-5889	522	A	-26	-140	894	S637	-7189	522	A	-26	-140
845	S588	-5915	382	A	-26	140	895	S638	-7215	382	A	-26	140
846	S589	-5941	522	A	-26	-140	896	S639	-7241	522	A	-26	-140
847	S590	-5967	382	A	-26	140	897	S640	-7267	382	A	-26	140
848	S591	-5993	522	A	-26	-140	898	S641	-7293	522	A	-26	-140
849	S592	-6019	382	A	-26	140	899	S642	-7319	382	A	-26	140
850	S593	-6045	522	A	-26	-140	900	S643	-7345	522	A	-26	-140

No.	Name	X	Y	BUMP size	X Pitch	Y Pitch
901	S644	-7371	382	A	-26	140
902	S645	-7397	522	A	-26	-140
903	S646	-7423	382	A	-26	140
904	S647	-7449	522	A	-26	-140
905	S648	-7475	382	A	-26	140
906	S649	-7501	522	A	-26	-140
907	S650	-7527	382	A	-26	140
908	S651	-7553	522	A	-26	-140
909	S652	-7579	382	A	-26	140
910	S653	-7605	522	A	-26	-140
911	S654	-7631	382	A	-26	140
912	S655	-7657	522	A	-26	-140
913	S656	-7683	382	A	-26	140
914	S657	-7709	522	A	-26	-140
915	S658	-7735	382	A	-26	140
916	S659	-7761	522	A	-26	-140
917	S660	-7787	382	A	-26	140
918	S661	-7813	522	A	-26	-140
919	S662	-7839	382	A	-26	140
920	S663	-7865	522	A	-26	-140
921	S664	-7891	382	A	-26	140
922	S665	-7917	522	A	-26	-140
923	S666	-7943	382	A	-26	140
924	S667	-7969	522	A	-26	-140
925	S668	-7995	382	A	-26	140
926	S669	-8021	522	A	-26	-140
927	S670	-8047	382	A	-26	140
928	S671	-8073	522	A	-26	-140
929	S672	-8099	382	A	-26	140
930	S673	-8125	522	A	-26	-140
931	S674	-8151	382	A	-26	140
932	S675	-8177	522	A	-26	-140
933	S676	-8203	382	A	-26	140
934	S677	-8229	522	A	-26	-140
935	S678	-8255	382	A	-26	140
936	S679	-8281	522	A	-26	-140
937	S680	-8307	382	A	-26	140
938	S681	-8333	522	A	-26	-140
939	S682	-8359	382	A	-26	140
940	S683	-8385	522	A	-26	-140
941	S684	-8411	382	A	-26	140
942	S685	-8437	522	A	-26	-140
943	S686	-8463	382	A	-26	140
944	S687	-8489	522	A	-26	-140
945	S688	-8515	382	A	-26	140
946	S689	-8541	522	A	-26	-140
947	S690	-8567	382	A	-26	140
948	S691	-8593	522	A	-26	-140
949	S692	-8619	382	A	-26	140
950	S693	-8645	522	A	-26	-140

No.	Name	X	Y	BUMP size	X Pitch	Y Pitch
951	S694	-8671	382	A	-26	140
952	S695	-8697	522	A	-26	-140
953	S696	-8723	382	A	-26	140
954	S697	-8749	522	A	-26	-140
955	S698	-8775	382	A	-26	140
956	S699	-8801	522	A	-26	-140
957	S700	-8827	382	A	-26	140
958	S701	-8853	522	A	-26	-140
959	S702	-8879	382	A	-26	140
960	S703	-8905	522	A	-26	-140
961	S704	-8931	382	A	-26	140
962	S705	-8957	522	A	-26	-140
963	S706	-8983	382	A	-26	140
964	S707	-9009	522	A	-26	-140
965	S708	-9035	382	A	-26	140
966	S709	-9061	522	A	-26	-140
967	S710	-9087	382	A	-26	140
968	S711	-9113	522	A	-26	-140
969	S712	-9139	382	A	-26	140
970	S713	-9165	522	A	-26	-140
971	S714	-9191	382	A	-26	140
972	S715	-9217	522	A	-26	-140
973	S716	-9243	382	A	-26	140
974	S717	-9269	522	A	-26	-140
975	S718	-9295	382	A	-26	140
976	S719	-9321	522	A	-26	-140
977	S720	-9347	382	A	-26	140
978	DUMMY	-9373	522	A	-26	-150
979	DUMMY	-9399	372	C	-26	140
980	DUMMY	-9425	512	C	-26	-140
981	DUMMY	-9451	372	C		
982	OE_L	-9422	260	B	0	-70
983	OE_L	-9422	190	B	0	-80
984	CKV_L	-9422	110	B	0	-70
985	CKV_L	-9422	40	B	0	-80
986	STV_L	-9422	-40	B	0	-70
987	STV_L	-9422	-110	B	0	-80
988	COMSIG_L	-9422	-190	B	0	-70
989	COMSIG_L	-9422	-260	B		

Name	X	Y
Alignment Mark (1-a)	-9201.8	-344
Alignment Mark (1-b)	9201.8	-344

5. Pin Description

Pin name	I/O	Description
S[1:720]	O	Source driver output.
D27~D20 D17~D10 D07~D00	I	Digital data input. Internally pulled low. PS=H (parallel RGB interface): Dx7~Dx0 are used. PS=L (serial RGB interface): only D07~D00 are used.
MS	I	Master or Slave mode selection. MS=H: master mode MS=L: slave mode
LR	I	Shift direction selection signal. Internally pulled high. Shift direction of the internal shift register is controlled by this pin as shown below: LR=H: S1→S2 →•••→S720 LR=L: S720→S719→•••→S1
CLK	I	Clock signal for data latching and internal counter of the timing controller.
CLK_TRG	I	Clock edge selection signal for the data sampling. Internally pulled high. CLK_TRG=H: Data sampling at the CLK falling edge. CLK_TRG=L: Data sampling at the CLK rising edge.
HS	I	Horizontal sync input with negative polarity.
VS	I	Vertical sync input with negative polarity.
DE	I	Input data enable control. Internally pulled low.
CKV	O	Gate driver clock.
STV	O	Gate driver start pulse.
OEV	O	Gate driver output control.
COMSIG	O	Common control signal, output to gate driver to generate common signal.
RESETB	I	Active low global reset signal input. Internally pulled high.
DISP	I	Display on/off mode control. Internally pulled high. When DISP=L, input data are invalid and blank data are written to data register automatically.
DISPG	O	Display on/off mode control output pin to gate driver.
V0 ~ V13	I/O	Gamma reference voltage input pins. Supply these voltages from outside with operational amplifiers. Make sure to maintain the following relationships: AVDD-0.2V > V0 > V1 > ... > V5 > V6 > AVSS+0.2V AVDD-0.2V > V7 > V8 > ... > V12 > V13 > AVSS+0.2V
PS	I	Input data format select signal. Internally pulled high. PS=H: Parallel RGB PS=L: Serial RGB
LF	I	Line / Frame inversion select signal. Internally pulled high. LF=H: Line inversion LF=L: Frame inversion
RES1, RES2	I	Resolution select signal. Internally pulled high. a. RES2=H, RES1=H: 480RGB x 272 RES2=H, RES1=L: 480RGB x 240 b. RES2=L, RES1=H: 240RGB x 320 RES2=L, RES1=L: 240RGB x 240
NBW	I	LC type selection. Internally pulled high. NBW=H: Normally black LC. NBW=L: Normally white LC.

Pin name	I/O	Description
TEST1	I	Test mode pin. Set "H or open" for normal operation. Internally pulled high.
TEST2	I	Test mode pin. Set "H or open" for normal operation. Internally pulled high.
TEST3	I	Test mode pin. Set "H or open" for normal operation. Internally pulled high.
TEST_IO1	I/O	Monitor pin for TEST mode. Another function is input pin of Slave IC. Please reference the description of TEST_IO3
TEST_IO2	I/O	Monitor pin for TEST mode. In normal mode, this is strapping pin to select MS and LR function (please see 6.1). Internally pulled low. TEST_IO2=H: Internal MS signal is decided by RES2, MS and LR pins TEST_IO2=L: Internal MS signal is decided by RES2 and MS pins
TEST_IO3	I/O	Monitor pin for TEST mode. In normal mode, this pin is POL (gamma polarity) signal output of Master IC, and used to connect TEST_IO1 of Slave IC that sync 2 IC's gamma polarity
TEST_IO4	I/O	Monitor pin for TEST mode. Internally pulled low
DVDD	VI	Digital power supply. 2.25V ~ 3.6V
DVSS	VI	Digital GND.
AVDD	VI	Analog power supply. 4.8V ~ 5.2V
AVSS	VI	Analog GND.

Note: (1) Please power on following the sequence DVDD → logic input → AVDD and V0 ~ V13. Reverse the sequence to shut down.

(2) To stabilize the supply voltages, please be sure to insert a 0.1uF bypass capacitor between DVDD-DVSS and AVDD-AVSS. Furthermore, for increased precision of the D/A converter, insertion of a bypass capacitor of about 0.01uF is also advised between the gamma-corrected power supply terminals (V0, V1, ..., V13) and AVSS.

6. Function Description

6.1 Resolutions and Master / Slave Modes

HX8227-A01 has 4 different resolutions, set by RES1, RES2 pins as Table 6.1. Since HX8227-A01 has 720 channel, two HX8227-A01 source drivers can be cascaded for extended 1440 channel of the 480RGB resolutions (RES2 = H).

RES2	RES1	Display Resolution
H	H	480RGB x 272
H	L	480RGB x 240
L	H	240RGB x 320
L	L	240RGB x 240

Table 6. 1 Resolution setting

For 480RGB resolutions, HX8227-A01 has 2 modes of timing control circuit, the Master mode or the Slave mode. When HX8227-A01 is set as Master mode, it latches the display data from the 1st clock at DE active regions. Otherwise, HX8227-A01 starts latching data from either the 241st clock in parallel interface (PS="H"), or from the 721st clock in serial interface (PS="L"). On the contrary, when HX8227-A01 is set in 240RGB resolutions (RES2="L"), it is always considered as the master, and starts latching data from the 1st clock at DE active region. By setting RES2, MS, LR and TEST_IO2 pins can control the direction of latched display data. The setting examples showed in Figure 6.3 and Figure 6.4.

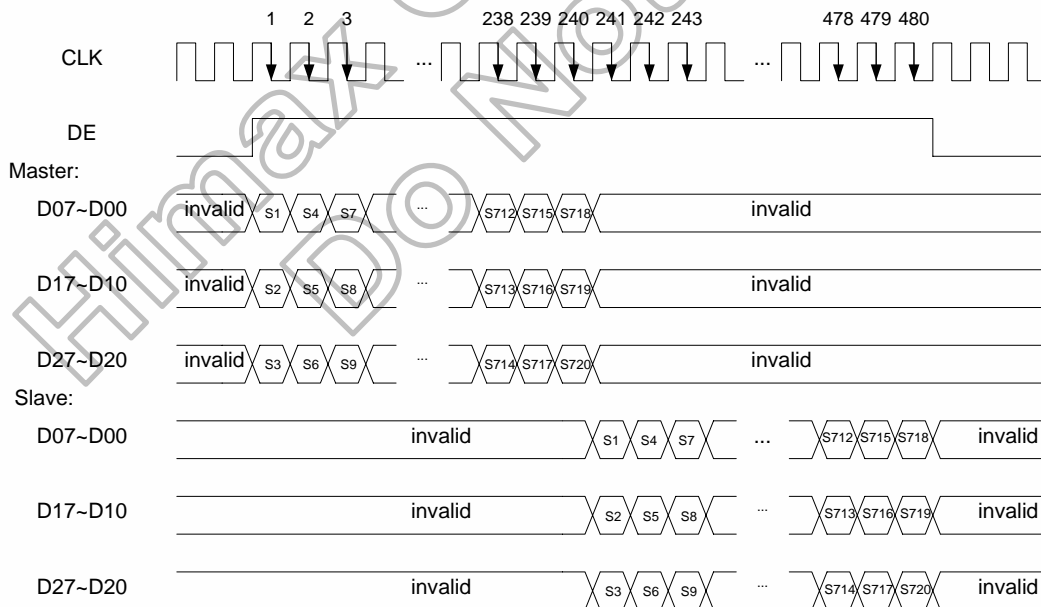

Figure 6. 1 Example of 480RGBx272, parallel RGB

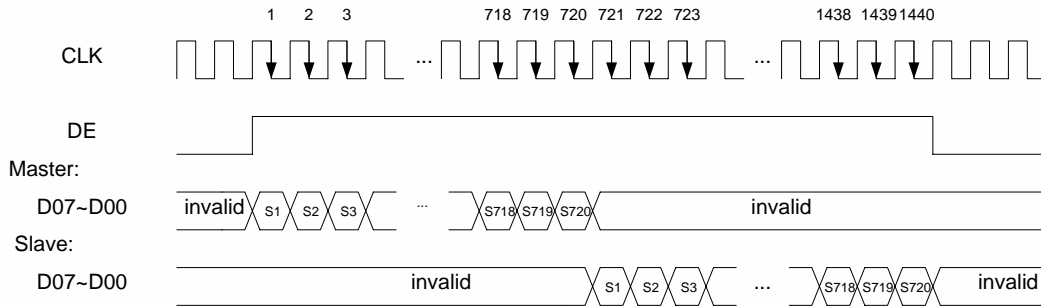

Figure 6. 2 Example of 480RGBx272, serial RGB

6.2 Parallel / Serial Mode and LR function

HX8227-A01 has 2 modes for input interface, parallel and serial interface. In parallel interface (PS="H"), 24-bit data are transferred into HX8227-A01 each cycle when DE is activated. Meanwhile, if LR="H" (right shift), D07 to D00 is displayed for output channel S_{3n-2} , D17 to D10 are displayed for channel S_{3n-1} , and D27 to D20 are displayed for channel S_{3n} , where $n=1, 2, \dots$ to 240 sequentially. The relationship between display data and source output is shown in the following figure. If LR="L" (left shift), D07 to D00, D17 to D10, and D27 to D20 are still displayed for channel S_{3n-2} , S_{3n-1} , and S_{3n} , respectively, but $n=240, 239 \dots$ to 1 sequentially.

Input data format: 24-bit RGB, 3 dots (sub-pixels) per clock

Input data width: 24 bits with Dx7 is MSB and Dx0 is LSB, $x = 1 \sim 3$

LR	First			→	Last		
	D00~D07	D10~D17	D20~D27		D00~D07	D10~D17	D20~D27
H	S1	S2	S3	...	S718	S719	S720

LR	Last			←	First		
	D00~D07	D10~D17	D20~D27		D00~D07	D10~D17	D20~D27
L	S1	S2	S3	...	S718	S719	S720

In serial interface (PS="L"), 8-bit data are transferred into HX8227-A01 through D07~D00 pins. The data are latched sequentially for channel S_{3n-2} , S_{3n-1} , S_{3n} , $n=1, 2 \dots, 240$ when LR="H", and for S_{3n} , S_{3n-1} , S_{3n-2} , $n=240, 239, 238 \dots$ to 1 when LR=L.

Input data format: 8-bit RGB, 1 dot (sub-pixel) per clock

Input data width: 8 bits with D07 is MSB and D00 is LSB

LR	First			→	Last		
	D00~D07	D00~D07	D00~D07		D00~D07	D00~D07	D00~D07
H	S1	S2	S3	...	S718	S719	S720

LR	Last			←	First		
	D00~D07	D00~D07	D00~D07		D00~D07	D00~D07	D00~D07
L	S1	S2	S3	...	S718	S719	S720

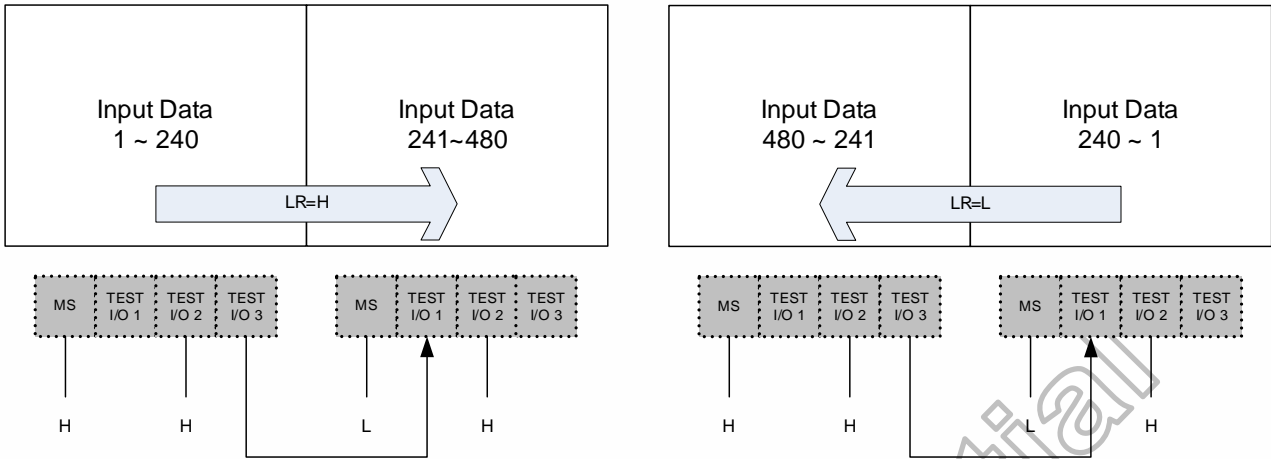

Figure 6. 3 Example of 480x272 control setting when TEST I/O 2=H and fixed M/S

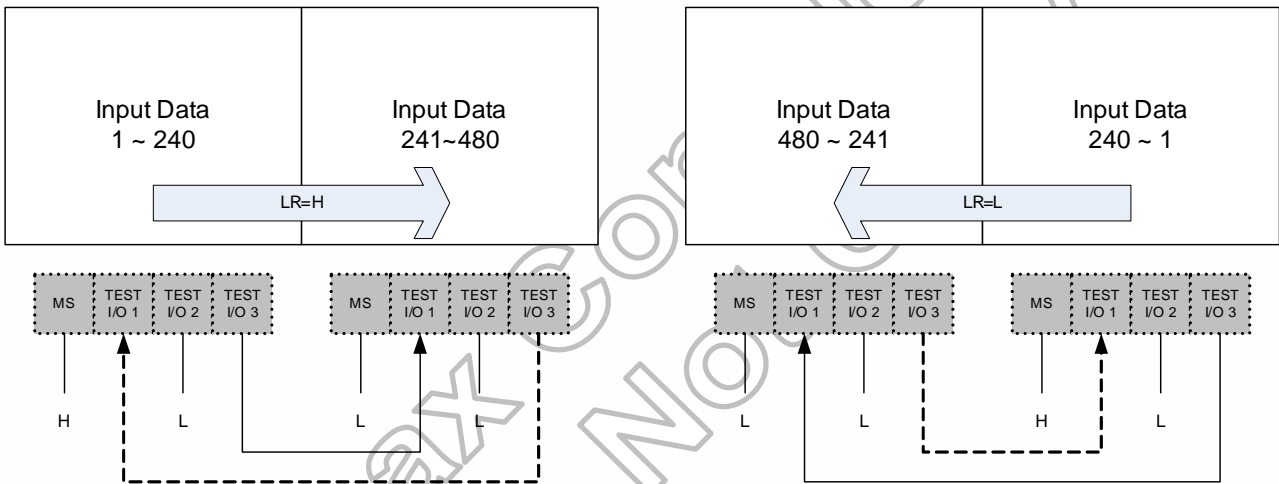

Figure 6. 4 Example of 480x272 control setting when TEST I/O 2=L and unfixed M/S

6.3 Source Driver Function

HX8227-A01 incorporates 8-bit D/A Converters to transfer input digital data into output analog voltage for each channel. The D/A converters are consists of ladder resistors and switches. The ladder resistors (R0 to R254) are designed so that the ratio of LCD panel gamma-compensated voltages V_{0p} to V_{255p} for positive and V_{0n} to V_{255n} for negative polarity. There are two sets of 7 gamma-compensated power supplies, which are V0 to V6, V7 to V13.

Figure 6. 5 show relationship between the internal gamma-compensation circuit and the converted analog voltages for both polarities. Gamma-compensation circuit is consisted of gamma-ladder resistors and polarity select switches. The polarity select switches change the connection of gamma-resistor and D/A converter according to the timing of driving polarity.

The converted analog voltages VR, VG, and VB are then sampled, and held by the 720-channel driver, then output through unit gain buffers. The relationship between the source driver output and the input data are shown in Figure 6. 5. For the gamma-correction reference voltages V0 to V13, AVDD, and AVSS, be sure to maintain the voltage relationships of the following power supplies:

$$AVDD - 0.2V \geq V0 > V1 > V2 > V3 > \dots > V6 \geq AVSS + 0.2V.$$

$$AVDD - 0.2V \geq V7 > V8 > V9 > V10 > \dots > V13 \geq AVSS + 0.2V.$$

From page 23 to page 26 showed the relationship between the input data and the output voltage. The resistance value of the resistor strings is also listed in page 22.

The two sets of 256 gray level voltages are generated by two resistor strings inside the HX8227-A01 as shown in Figure 6. 6. One set is for positive polarity and the other set is for negative polarity.

There are 14 terminals, V0 to V13, controlled by external gamma reference voltages, where 7 terminals (V0 to V6) are for positive polarity and another 7 terminals (V7 to V13) are for negative polarity.

Users must provide at least 4 external gamma reference voltages, V0, V6, V7, and V13, to HX8227-A01. However, those gray level voltages output by HX8227-A01 may not be matched users' liquid crystal characteristic well since fewer external gamma reference voltages are provided.

Or, users could provide all of 14 external gamma reference voltages, V0 to V13, to HX8227-A01. In this case, those gray level voltages output by HX8227-A01 could be matched users' liquid crystal characteristic well.

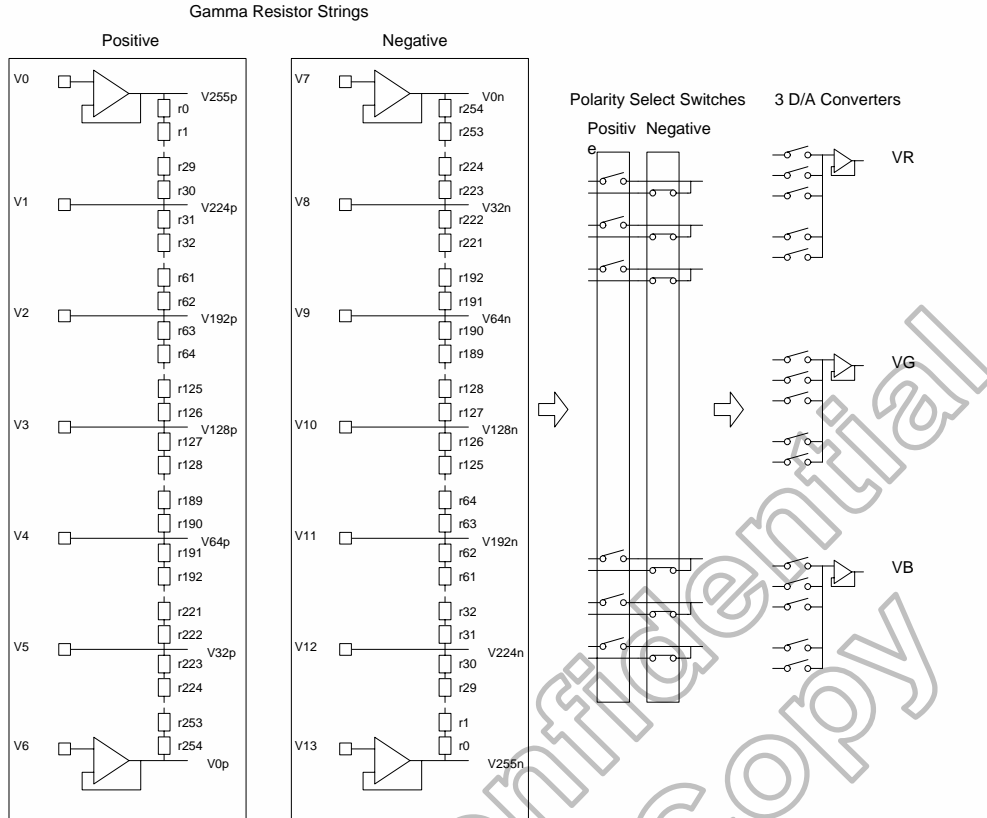

Figure 6. 5 Relationship between the internal gamma-compensation circuits

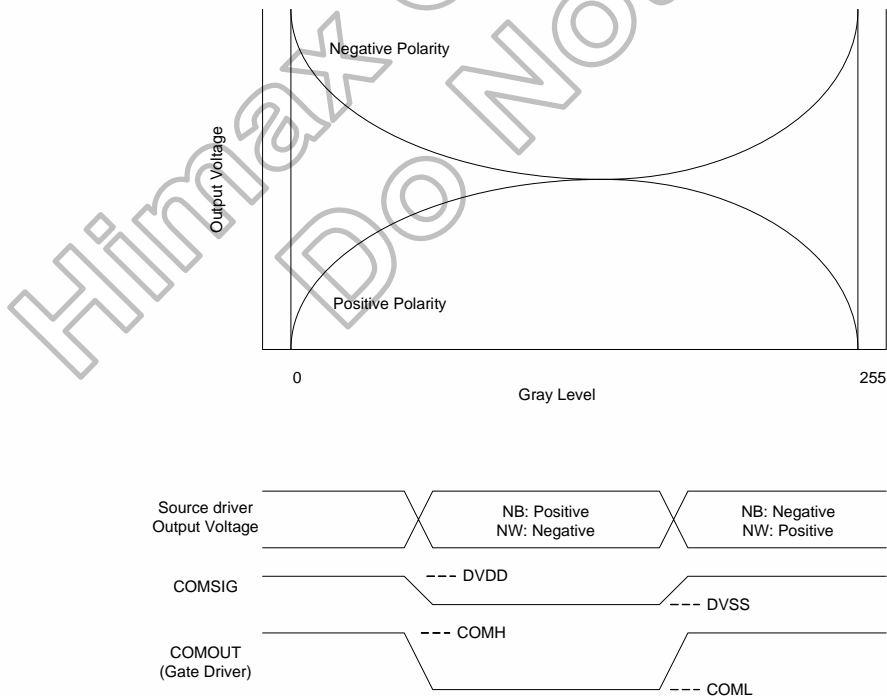

Figure 6. 6 Relationship between NB and NW output polarity

Ladder resistors ratio

Rn	Ω	Rn	Ω	Rn	Ω	Rn	Ω	Rn	Ω
R0	627.2	R51	37.6	R102	27.0	R153	42.1	R204	60.1
R1	627.2	R52	37.6	R103	27.0	R154	42.1	R205	58.6
R2	627.2	R53	34.5	R104	27.0	R155	42.1	R206	58.6
R3	627.2	R54	34.5	R105	18.0	R156	42.1	R207	58.6
R4	627.2	R55	34.5	R106	18.0	R157	36.0	R208	58.6
R5	148.7	R56	34.5	R107	18.0	R158	36.0	R209	67.6
R6	148.7	R57	36.0	R108	18.0	R159	36.0	R210	67.6
R7	148.7	R58	36.0	R109	39.1	R160	36.0	R211	67.6
R8	148.7	R59	36.0	R110	39.1	R161	39.1	R212	67.6
R9	102.1	R60	36.0	R111	39.1	R162	39.1	R213	75.1
R10	102.1	R61	33.0	R112	39.1	R163	39.1	R214	75.1
R11	102.1	R62	33.0	R113	34.5	R164	39.1	R215	75.1
R12	102.1	R63	33.0	R114	34.5	R165	40.6	R216	75.1
R13	82.6	R64	33.0	R115	34.5	R166	40.6	R217	78.1
R14	82.6	R65	40.6	R116	34.5	R167	40.6	R218	78.1
R15	82.6	R66	40.6	R117	31.5	R168	40.6	R219	78.1
R16	82.6	R67	40.6	R118	31.5	R169	37.6	R220	78.1
R17	64.6	R68	40.6	R119	31.5	R170	37.6	R221	79.6
R18	64.6	R69	40.6	R120	31.5	R171	37.6	R222	79.6
R19	64.6	R70	40.6	R121	45.1	R172	37.6	R223	79.6
R20	64.6	R71	40.6	R122	45.1	R173	45.1	R224	79.6
R21	58.6	R72	40.6	R123	45.1	R174	45.1	R225	100.6
R22	58.6	R73	42.1	R124	45.1	R175	45.1	R226	100.6
R23	58.6	R74	42.1	R125	21.0	R176	45.1	R227	100.6
R24	58.6	R75	42.1	R126	21.0	R177	39.1	R228	100.6
R25	54.1	R76	42.1	R127	21.0	R178	39.1	R229	108.1
R26	54.1	R77	21.0	R128	21.0	R179	39.1	R230	108.1
R27	54.1	R78	21.0	R129	33.0	R180	39.1	R231	108.1
R28	54.1	R79	21.0	R130	33.0	R181	43.6	R232	108.1
R29	54.1	R80	21.0	R131	33.0	R182	43.6	R233	114.2
R30	54.1	R81	30.0	R132	33.0	R183	43.6	R234	114.2
R31	54.1	R82	30.0	R133	36.0	R184	43.6	R235	114.2
R32	54.1	R83	30.0	R134	36.0	R185	52.6	R236	114.2
R33	45.1	R84	30.0	R135	36.0	R186	52.6	R237	120.2
R34	45.1	R85	36.0	R136	36.0	R187	52.6	R238	120.2
R35	45.1	R86	36.0	R137	24.0	R188	52.6	R239	120.2
R36	45.1	R87	36.0	R138	24.0	R189	48.1	R240	120.2
R37	33.0	R88	36.0	R139	24.0	R190	48.1	R241	105.1
R38	33.0	R89	27.0	R140	24.0	R191	48.1	R242	105.1
R39	33.0	R90	27.0	R141	34.5	R192	48.1	R243	105.1
R40	33.0	R91	27.0	R142	34.5	R193	57.1	R244	105.1
R41	39.1	R92	27.0	R143	34.5	R194	57.1	R245	120.2
R42	39.1	R93	33.0	R144	34.5	R195	57.1	R246	120.2
R43	39.1	R94	33.0	R145	34.5	R196	57.1	R247	120.2
R44	39.1	R95	33.0	R146	34.5	R197	54.1	R248	120.2
R45	39.1	R96	33.0	R147	34.5	R198	54.1	R249	198.3
R46	39.1	R97	30.0	R148	34.5	R199	54.1	R250	198.3
R47	39.1	R98	30.0	R149	33.0	R200	54.1	R251	204.3
R48	39.1	R99	30.0	R150	33.0	R201	60.1	R252	198.3
R49	37.6	R100	30.0	R151	33.0	R202	60.1	R253	198.3
R50	37.6	R101	27.0	R152	33.0	R203	60.1	R254	204.3
							Total	17123.0	

Input data and output voltage

INPUT DATA									OUTPUT VOLTAGE	
Hex	Dx7	Dx6	Dx5	Dx4	Dx3	Dx2	Dx1	Dx0	Positive	Negative
0	0	0	0	0	0	0	0	0	V6	V7
1	0	0	0	0	0	0	0	1	$V6+(V5-V6)*(204.3/4034.4)$	$V8+(V7-V8)*(3830.1/4034.4)$
2	0	0	0	0	0	0	0	1	$V6+(V5-V6)*(402.5/4034.4)$	$V8+(V7-V8)*(3631.9/4034.4)$
3	0	0	0	0	0	0	0	1	$V6+(V5-V6)*(600.8/4034.4)$	$V8+(V7-V8)*(3433.6/4034.4)$
4	0	0	0	0	0	0	1	0	$V6+(V5-V6)*(805.1/4034.4)$	$V8+(V7-V8)*(3229.3/4034.4)$
5	0	0	0	0	0	1	0	1	$V6+(V5-V6)*(1003.3/4034.4)$	$V8+(V7-V8)*(3031.1/4034.4)$
6	0	0	0	0	0	1	1	0	$V6+(V5-V6)*(1201.6/4034.4)$	$V8+(V7-V8)*(2832.8/4034.4)$
7	0	0	0	0	0	1	1	1	$V6+(V5-V6)*(1321.8/4034.4)$	$V8+(V7-V8)*(2712.6/4034.4)$
8	0	0	0	0	1	0	0	0	$V6+(V5-V6)*(1441.9/4034.4)$	$V8+(V7-V8)*(2592.5/4034.4)$
9	0	0	0	0	1	0	0	1	$V6+(V5-V6)*(1562.1/4034.4)$	$V8+(V7-V8)*(2472.3/4034.4)$
0A	0	0	0	0	1	0	1	0	$V6+(V5-V6)*(1682.3/4034.4)$	$V8+(V7-V8)*(2352.3/4034.4)$
0B	0	0	0	0	1	0	1	1	$V6+(V5-V6)*(1787.4/4034.4)$	$V8+(V7-V8)*(2247.0/4034.4)$
0C	0	0	0	0	1	1	0	0	$V6+(V5-V6)*(1892.5/4034.4)$	$V8+(V7-V8)*(2141.9/4034.4)$
0D	0	0	0	0	1	1	0	1	$V6+(V5-V6)*(1997.7/4034.4)$	$V8+(V7-V8)*(2036.7/4034.4)$
0E	0	0	0	0	1	1	1	0	$V6+(V5-V6)*(2102.8/4034.4)$	$V8+(V7-V8)*(1931.6/4034.4)$
0F	0	0	0	0	1	1	1	1	$V6+(V5-V6)*(2223.0/4034.4)$	$V8+(V7-V8)*(1811.4/4034.4)$
10	0	0	0	1	0	0	0	0	$V6+(V5-V6)*(2343.1/4034.4)$	$V8+(V7-V8)*(1691.3/4034.4)$
11	0	0	0	1	0	0	0	1	$V6+(V5-V6)*(2463.3/4034.4)$	$V8+(V7-V8)*(1571.1/4034.4)$
12	0	0	0	1	0	0	1	0	$V6+(V5-V6)*(2583.5/4034.4)$	$V8+(V7-V8)*(1450.9/4034.4)$
13	0	0	0	1	0	0	1	1	$V6+(V5-V6)*(2697.6/4034.4)$	$V8+(V7-V8)*(1336.8/4034.4)$
14	0	0	0	1	0	1	0	0	$V6+(V5-V6)*(2811.8/4034.4)$	$V8+(V7-V8)*(1222.6/4034.4)$
15	0	0	0	1	0	1	0	1	$V6+(V5-V6)*(2925.9/4034.4)$	$V8+(V7-V8)*(1108.5/4034.4)$
16	0	0	0	1	0	1	1	0	$V6+(V5-V6)*(3040.1/4034.4)$	$V8+(V7-V8)*(994.3/4034.4)$
17	0	0	0	1	0	1	1	1	$V6+(V5-V6)*(3148.2/4034.4)$	$V8+(V7-V8)*(886.2/4034.4)$
18	0	0	0	1	1	0	0	0	$V6+(V5-V6)*(3256.4/4034.4)$	$V8+(V7-V8)*(778.0/4034.4)$
19	0	0	0	1	1	0	0	1	$V6+(V5-V6)*(3364.5/4034.4)$	$V8+(V7-V8)*(669.6/4034.4)$
1A	0	0	0	1	1	0	1	0	$V6+(V5-V6)*(3472.7/4034.4)$	$V8+(V7-V8)*(561.8/4034.4)$
1B	0	0	0	1	1	0	1	1	$V6+(V5-V6)*(3573.3/4034.4)$	$V8+(V7-V8)*(461.1/4034.4)$
1C	0	0	0	1	1	1	0	0	$V6+(V5-V6)*(3673.9/4034.4)$	$V8+(V7-V8)*(360.5/4034.4)$
1D	0	0	0	1	1	1	0	1	$V6+(V5-V6)*(3774.6/4034.4)$	$V8+(V7-V8)*(259.8/4034.4)$
1E	0	0	0	1	1	1	1	0	$V6+(V5-V6)*(3875.2/4034.4)$	$V8+(V7-V8)*(159.2/4034.4)$
1F	0	0	0	1	1	1	1	1	$V6+(V5-V6)*(3954.8/4034.4)$	$V8+(V7-V8)*(79.6/4034.4)$
20	0	0	1	0	0	0	0	0	V5	V8
21	0	0	1	0	0	0	0	1	$V5+(V4-V5)*(79.6/2057.8)$	$V9+(V8-V9)*(1978.2/2057.8)$
22	0	0	1	0	0	0	1	0	$V5+(V4-V5)*(159.2/2057.8)$	$V9+(V8-V9)*(1898.6/2057.8)$
23	0	0	1	0	0	0	1	1	$V5+(V4-V5)*(237.3/2057.8)$	$V9+(V8-V9)*(1820.4/2057.8)$
24	0	0	1	0	0	1	0	0	$V5+(V4-V5)*(315.41/2057.8)$	$V9+(V8-V9)*(1742.3/2057.8)$
25	0	0	1	0	0	1	0	1	$V5+(V4-V5)*(393.5/2057.8)$	$V9+(V8-V9)*(1664.2/2057.8)$
26	0	0	1	0	0	1	1	0	$V5+(V4-V5)*(471.6/2057.8)$	$V9+(V8-V9)*(1586.1/2057.8)$
27	0	0	1	0	0	1	1	1	$V5+(V4-V5)*(546.7/2057.8)$	$V9+(V8-V9)*(1511.0/2057.8)$
28	0	0	1	0	1	0	0	0	$V5+(V4-V5)*(621.8/2057.8)$	$V9+(V8-V9)*(1435.9/2057.8)$
29	0	0	1	0	1	0	0	1	$V5+(V4-V5)*(696.9/2057.8)$	$V9+(V8-V9)*(1360.8/2057.8)$
2A	0	0	1	0	1	0	1	0	$V5+(V4-V5)*(772.0/2057.8)$	$V9+(V8-V9)*(1285.7/2057.8)$
2B	0	0	1	0	1	0	1	1	$V5+(V4-V5)*(839.6/2057.8)$	$V9+(V8-V9)*(1218.1/2057.8)$
2C	0	0	1	0	1	1	0	0	$V5+(V4-V5)*(907.2/2057.8)$	$V9+(V8-V9)*(1150.5/2057.8)$
2D	0	0	1	0	1	1	0	1	$V5+(V4-V5)*(974.8/2057.8)$	$V9+(V8-V9)*(1083.0/2057.8)$
2E	0	0	1	0	1	1	1	0	$V5+(V4-V5)*(1042.4/2057.8)$	$V9+(V8-V9)*(1015.4/2057.8)$
2F	0	0	1	0	1	1	1	1	$V5+(V4-V5)*(1101.0/2057.8)$	$V9+(V8-V9)*(956.8/2057.8)$
30	0	0	1	1	0	0	0	0	$V5+(V4-V5)*(1159.6/2057.8)$	$V9+(V8-V9)*(898.2/2057.8)$
31	0	0	1	1	0	0	0	1	$V5+(V4-V5)*(1218.1/2057.8)$	$V9+(V8-V9)*(839.6/2057.8)$
32	0	0	1	1	0	0	1	0	$V5+(V4-V5)*(1276.7/2057.8)$	$V9+(V8-V9)*(781.0/2057.8)$
33	0	0	1	1	0	0	1	1	$V5+(V4-V5)*(1336.8/2057.8)$	$V9+(V8-V9)*(721.0/2057.8)$
34	0	0	1	1	0	1	0	0	$V5+(V4-V5)*(1396.9/2057.8)$	$V9+(V8-V9)*(660.9/2057.8)$
35	0	0	1	1	0	1	0	1	$V5+(V4-V5)*(1457.0/2057.8)$	$V9+(V8-V9)*(600.8/2057.8)$
36	0	0	1	1	0	1	1	0	$V5+(V4-V5)*(1517.0/2057.8)$	$V9+(V8-V9)*(540.7/2057.8)$
37	0	0	1	1	0	1	1	1	$V5+(V4-V5)*(1571.1/2057.8)$	$V9+(V8-V9)*(486.7/2057.8)$
38	0	0	1	1	1	0	0	0	$V5+(V4-V5)*(1625.2/2057.8)$	$V9+(V8-V9)*(432.6/2057.8)$
39	0	0	1	1	1	0	0	1	$V5+(V4-V5)*(1679.3/2057.8)$	$V9+(V8-V9)*(378.5/2057.8)$
3A	0	0	1	1	1	0	1	0	$V5+(V4-V5)*(1733.3/2057.8)$	$V9+(V8-V9)*(324.4/2057.8)$
3B	0	0	1	1	1	0	1	1	$V5+(V4-V5)*(1790.4/2057.8)$	$V9+(V8-V9)*(267.4/2057.8)$
3C	0	0	1	1	1	1	0	0	$V5+(V4-V5)*(1847.5/2057.8)$	$V9+(V8-V9)*(210.3/2057.8)$
3D	0	0	1	1	1	1	0	1	$V5+(V4-V5)*(1904.6/2057.8)$	$V9+(V8-V9)*(153.2/2057.8)$
3E	0	0	1	1	1	1	1	0	$V5+(V4-V5)*(1961.6/2057.8)$	$V9+(V8-V9)*(96.1/2057.8)$
3F	0	0	1	1	1	1	1	1	$V5+(V4-V5)*(2009.7/2057.8)$	$V9+(V8-V9)*(48.1/2057.8)$

Hex	INPUT DATA								OUTPUT VOLTAGE	
	Dx7	Dx6	Dx5	Dx4	Dx3	Dx2	Dx1	Dx0	Positive	Negative
40	0	1	0	0	0	0	0	0	V4	V9
41	0	1	0	0	0	0	0	1	V4+(V3-V4)*(48.1/2421.3)	V10+(V9-V10)*(2373.2/2421.3)
42	0	1	0	0	0	0	1	0	V4+(V3-V4)*(96.1/2421.3)	V10+(V9-V10)*(2352.1/2421.3)
43	0	1	0	0	0	0	1	1	V4+(V3-V4)*(148.7/2421.3)	V10+(V9-V10)*(2272.6/2421.3)
44	0	1	0	0	0	1	0	0	V4+(V3-V4)*(201.3/2421.3)	V10+(V9-V10)*(2220.0/2421.3)
45	0	1	0	0	0	1	0	1	V4+(V3-V4)*(253.8/2421.3)	V10+(V9-V10)*(2167.4/2421.3)
46	0	1	0	0	0	1	1	0	V4+(V3-V4)*(306.4/2421.3)	V10+(V9-V10)*(2114.8/2421.3)
47	0	1	0	0	0	1	1	1	V4+(V3-V4)*(350.0/2421.3)	V10+(V9-V10)*(2071.3/2421.3)
48	0	1	0	0	1	0	0	0	V4+(V3-V4)*(393.5/2421.3)	V10+(V9-V10)*(2027.7/2421.3)
49	0	1	0	0	1	0	0	1	V4+(V3-V4)*(437.1/2421.3)	V10+(V9-V10)*(1984.2/2421.3)
4A	0	1	0	0	1	0	1	0	V4+(V3-V4)*(480.6/2421.3)	V10+(V9-V10)*(1940.6/2421.3)
4B	0	1	0	0	1	0	1	1	V4+(V3-V4)*(519.7/2421.3)	V10+(V9-V10)*(1901.6/2421.3)
4C	0	1	0	0	1	1	0	0	V4+(V3-V4)*(558.8/2421.3)	V10+(V9-V10)*(1862.5/2421.3)
4D	0	1	0	0	1	1	0	1	V4+(V3-V4)*(597.8/2421.3)	V10+(V9-V10)*(1823.4/2421.3)
4E	0	1	0	0	1	1	1	0	V4+(V3-V4)*(636.9/2421.3)	V10+(V9-V10)*(1784.4/2421.3)
4F	0	1	0	0	1	1	1	1	V4+(V3-V4)*(681.9/2421.3)	V10+(V9-V10)*(1739.3/2421.3)
50	0	1	0	1	0	0	0	0	V4+(V3-V4)*(727.0/2421.3)	V10+(V9-V10)*(1694.3/2421.3)
51	0	1	0	1	0	0	0	1	V4+(V3-V4)*(772.0/2421.3)	V10+(V9-V10)*(1649.2/2421.3)
52	0	1	0	1	0	0	1	0	V4+(V3-V4)*(817.1/2421.3)	V10+(V9-V10)*(1604.2/2421.3)
53	0	1	0	1	0	0	1	1	V4+(V3-V4)*(854.6/2421.3)	V10+(V9-V10)*(1566.6/2421.3)
54	0	1	0	1	0	1	0	0	V4+(V3-V4)*(892.2/2421.3)	V10+(V9-V10)*(1529.1/2421.3)
55	0	1	0	1	0	1	0	1	V4+(V3-V4)*(929.7/2421.3)	V10+(V9-V10)*(1491.5/2421.3)
56	0	1	0	1	0	1	1	0	V4+(V3-V4)*(967.3/2421.3)	V10+(V9-V10)*(1454.0/2421.3)
57	0	1	0	1	0	1	1	1	V4+(V3-V4)*(1007.9/2421.3)	V10+(V9-V10)*(1413.4/2421.3)
58	0	1	0	1	1	0	0	0	V4+(V3-V4)*(1048.4/2421.3)	V10+(V9-V10)*(1372.8/2421.3)
59	0	1	0	1	1	0	0	1	V4+(V3-V4)*(1089.0/2421.3)	V10+(V9-V10)*(1332.3/2421.3)
5A	0	1	0	1	1	0	1	0	V4+(V3-V4)*(1129.5/2421.3)	V10+(V9-V10)*(1291.7/2421.3)
5B	0	1	0	1	1	0	1	1	V4+(V3-V4)*(1168.6/2421.3)	V10+(V9-V10)*(1252.7/2421.3)
5C	0	1	0	1	1	1	0	0	V4+(V3-V4)*(1207.6/2421.3)	V10+(V9-V10)*(1213.6/2421.3)
5D	0	1	0	1	1	1	0	1	V4+(V3-V4)*(1246.7/2421.3)	V10+(V9-V10)*(1174.6/2421.3)
5E	0	1	0	1	1	1	1	1	V4+(V3-V4)*(1285.7/2421.3)	V10+(V9-V10)*(1135.5/2421.3)
5F	0	1	0	1	1	1	1	1	V4+(V3-V4)*(1321.8/2421.3)	V10+(V9-V10)*(1099.5/2421.3)
60	0	1	1	0	0	0	0	0	V4+(V3-V4)*(1357.8/2421.3)	V10+(V9-V10)*(1063.4/2421.3)
61	0	1	1	0	0	0	0	1	V4+(V3-V4)*(1393.9/2421.3)	V10+(V9-V10)*(1027.4/2421.3)
62	0	1	1	0	0	0	1	0	V4+(V3-V4)*(1429.9/2421.3)	V10+(V9-V10)*(991.3/2421.3)
63	0	1	1	0	0	0	1	1	V4+(V3-V4)*(1472.0/2421.3)	V10+(V9-V10)*(949.3/2421.3)
64	0	1	1	0	0	1	0	0	V4+(V3-V4)*(1514.0/2421.3)	V10+(V9-V10)*(907.2/2421.3)
65	0	1	1	0	0	1	0	1	V4+(V3-V4)*(1556.1/2421.3)	V10+(V9-V10)*(865.2/2421.3)
66	0	1	1	0	0	1	1	0	V4+(V3-V4)*(1598.1/2421.3)	V10+(V9-V10)*(823.1/2421.3)
67	0	1	1	0	0	1	1	1	V4+(V3-V4)*(1631.2/2421.3)	V10+(V9-V10)*(790.1/2421.3)
68	0	1	1	0	1	0	0	0	V4+(V3-V4)*(1664.2/2421.3)	V10+(V9-V10)*(757.0/2421.3)
69	0	1	1	0	1	0	0	1	V4+(V3-V4)*(1697.3/2421.3)	V10+(V9-V10)*(724.0/2421.3)
6A	0	1	1	0	1	0	0	0	V4+(V3-V4)*(1730.3/2421.3)	V10+(V9-V10)*(690.9/2421.3)
6B	0	1	1	0	1	0	1	1	V4+(V3-V4)*(1764.9/2421.3)	V10+(V9-V10)*(656.4/2421.3)
6C	0	1	1	0	1	1	0	0	V4+(V3-V4)*(1799.4/2421.3)	V10+(V9-V10)*(621.8/2421.3)
6D	0	1	1	0	1	1	0	1	V4+(V3-V4)*(1834.0/2421.3)	V10+(V9-V10)*(587.3/2421.3)
6E	0	1	1	0	1	1	1	0	V4+(V3-V4)*(1868.5/2421.3)	V10+(V9-V10)*(552.7/2421.3)
6F	0	1	1	0	1	1	1	1	V4+(V3-V4)*(1903.1/2421.3)	V10+(V9-V10)*(518.2/2421.3)
70	0	1	1	1	0	0	0	0	V4+(V3-V4)*(1937.6/2421.3)	V10+(V9-V10)*(483.6/2421.3)
71	0	1	1	1	0	0	0	1	V4+(V3-V4)*(1972.1/2421.3)	V10+(V9-V10)*(449.1/2421.3)
72	0	1	1	1	0	0	1	0	V4+(V3-V4)*(2006.7/2421.3)	V10+(V9-V10)*(414.6/2421.3)
73	0	1	1	1	0	0	1	1	V4+(V3-V4)*(2030.7/2421.3)	V10+(V9-V10)*(390.5/2421.3)
74	0	1	1	1	0	1	0	0	V4+(V3-V4)*(2054.8/2421.3)	V10+(V9-V10)*(366.5/2421.3)
75	0	1	1	1	0	1	0	1	V4+(V3-V4)*(2078.8/2421.3)	V10+(V9-V10)*(342.5/2421.3)
76	0	1	1	1	0	1	1	0	V4+(V3-V4)*(2102.8/2421.3)	V10+(V9-V10)*(318.4/2421.3)
77	0	1	1	1	0	1	1	1	V4+(V3-V4)*(2138.9/2421.3)	V10+(V9-V10)*(282.4/2421.3)
78	0	1	1	1	1	0	0	0	V4+(V3-V4)*(2174.9/2421.3)	V10+(V9-V10)*(246.3/2421.3)
79	0	1	1	1	1	0	0	1	V4+(V3-V4)*(2211.0/2421.3)	V10+(V9-V10)*(210.3/2421.3)
7A	0	1	1	1	1	0	1	0	V4+(V3-V4)*(2247.0/2421.3)	V10+(V9-V10)*(174.2/2421.3)
7B	0	1	1	1	1	0	1	1	V4+(V3-V4)*(2283.1/2421.3)	V10+(V9-V10)*(141.2/2421.3)
7C	0	1	1	1	1	1	0	0	V4+(V3-V4)*(2313.1/2421.3)	V10+(V9-V10)*(108.1/2421.3)
7D	0	1	1	1	1	1	0	1	V4+(V3-V4)*(2346.2/2421.3)	V10+(V9-V10)*(75.1/2421.3)
7E	0	1	1	1	1	1	1	0	V4+(V3-V4)*(2379.2/2421.3)	V10+(V9-V10)*(42.1/2421.3)
7F	0	1	1	1	1	1	1	1	V4+(V3-V4)*(2400.2/2421.3)	V10+(V9-V10)*(21.0/2421.3)

Hex	INPUT DATA								OUTPUT VOLTAGE	
	Dx7	Dx6	Dx5	Dx4	Dx3	Dx2	Dx1	Dx0	Positive V3	Negative V10
80	1	0	0	0	0	0	0	0	V3+(V2-V3)*(21.0/2090.8)	V11+(V10-V11)*(2069.8/2090.8)
81	1	0	0	0	0	0	0	1	V3+(V2-V3)*(42.1/2090.8)	V11+(V10-V11)*(2048.8/2090.8)
82	1	0	0	0	0	0	1	0	V3+(V2-V3)*(87.1/2090.8)	V11+(V10-V11)*(2003.7/2090.8)
83	1	0	0	0	0	0	1	1	V3+(V2-V3)*(132.2/2090.8)	V11+(V10-V11)*(1958.6/2090.8)
84	1	0	0	0	0	1	0	0	V3+(V2-V3)*(177.2/2090.8)	V11+(V10-V11)*(1913.6/2090.8)
85	1	0	0	0	0	1	1	0	V3+(V2-V3)*(222.3/2090.8)	V11+(V10-V11)*(1868.5/2090.8)
86	1	0	0	0	0	1	1	1	V3+(V2-V3)*(253.8/2090.8)	V11+(V10-V11)*(1837.0/2090.8)
87	1	0	0	0	1	0	0	0	V3+(V2-V3)*(285.4/2090.8)	V11+(V10-V11)*(1805.4/2090.8)
88	1	0	0	0	1	0	0	1	V3+(V2-V3)*(316.9/2090.8)	V11+(V10-V11)*(1773.9/2090.8)
89	1	0	0	0	1	0	0	1	V3+(V2-V3)*(348.5/2090.8)	V11+(V10-V11)*(1742.3/2090.8)
8A	1	0	0	0	1	0	1	0	V3+(V2-V3)*(383.0/2090.8)	V11+(V10-V11)*(1707.8/2090.8)
8B	1	0	0	0	1	0	1	1	V3+(V2-V3)*(417.6/2090.8)	V11+(V10-V11)*(1673.2/2090.8)
8C	1	0	0	0	1	1	0	0	V3+(V2-V3)*(452.1/2090.8)	V11+(V10-V11)*(1638.7/2090.8)
8D	1	0	0	0	1	1	0	1	V3+(V2-V3)*(486.7/2090.8)	V11+(V10-V11)*(1604.2/2090.8)
8E	1	0	0	0	1	1	1	0	V3+(V2-V3)*(525.7/2090.8)	V11+(V10-V11)*(1565.1/2090.8)
8F	1	0	0	0	1	1	1	1	V3+(V2-V3)*(564.8/2090.8)	V11+(V10-V11)*(1526.0/2090.8)
90	1	0	0	1	0	0	0	0	V3+(V2-V3)*(603.8/2090.8)	V11+(V10-V11)*(1487.0/2090.8)
91	1	0	0	1	0	0	0	1	V3+(V2-V3)*(642.9/2090.8)	V11+(V10-V11)*(1447.9/2090.8)
92	1	0	0	1	0	0	1	0	V3+(V2-V3)*(660.9/2090.8)	V11+(V10-V11)*(1429.9/2090.8)
93	1	0	0	1	0	0	1	1	V3+(V2-V3)*(678.9/2090.8)	V11+(V10-V11)*(1411.9/2090.8)
94	1	0	0	1	0	1	0	0	V3+(V2-V3)*(696.9/2090.8)	V11+(V10-V11)*(1393.9/2090.8)
95	1	0	0	1	0	1	0	1	V3+(V2-V3)*(715.0/2090.8)	V11+(V10-V11)*(1375.8/2090.8)
96	1	0	0	1	0	1	1	0	V3+(V2-V3)*(742.0/2090.8)	V11+(V10-V11)*(1348.8/2090.8)
97	1	0	0	1	0	1	1	1	V3+(V2-V3)*(769.0/2090.8)	V11+(V10-V11)*(1321.8/2090.8)
98	1	0	0	1	1	0	0	0	V3+(V2-V3)*(796.1/2090.8)	V11+(V10-V11)*(1294.7/2090.8)
99	1	0	0	1	1	0	1	0	V3+(V2-V3)*(823.1/2090.8)	V11+(V10-V11)*(1267.7/2090.8)
9A	1	0	0	1	1	0	1	1	V3+(V2-V3)*(853.2/2090.8)	V11+(V10-V11)*(1237.7/2090.8)
9B	1	0	0	1	1	1	0	0	V3+(V2-V3)*(883.2/2090.8)	V11+(V10-V11)*(1207.6/2090.8)
9C	1	0	0	1	1	1	0	1	V3+(V2-V3)*(913.2/2090.8)	V11+(V10-V11)*(1177.6/2090.8)
9D	1	0	0	1	1	1	1	0	V3+(V2-V3)*(943.3/2090.8)	V11+(V10-V11)*(1147.5/2090.8)
9E	1	0	0	1	1	1	1	1	V3+(V2-V3)*(976.3/2090.8)	V11+(V10-V11)*(1114.5/2090.8)
9F	1	0	0	1	1	1	1	1	V3+(V2-V3)*(1009.4/2090.8)	V11+(V10-V11)*(1081.5/2090.8)
A0	1	0	1	0	0	0	0	0	V3+(V2-V3)*(1042.4/2090.8)	V11+(V10-V11)*(1048.4/2090.8)
A1	1	0	1	0	0	0	0	1	V3+(V2-V3)*(1075.4/2090.8)	V11+(V10-V11)*(1015.4/2090.8)
A2	1	0	1	0	0	0	1	0	V3+(V2-V3)*(1102.5/2090.8)	V11+(V10-V11)*(988.3/2090.8)
A3	1	0	1	0	0	0	1	1	V3+(V2-V3)*(1129.5/2090.8)	V11+(V10-V11)*(961.3/2090.8)
A4	1	0	1	0	0	1	0	0	V3+(V2-V3)*(1156.6/2090.8)	V11+(V10-V11)*(934.3/2090.8)
A5	1	0	1	0	0	1	0	1	V3+(V2-V3)*(1183.6/2090.8)	V11+(V10-V11)*(907.2/2090.8)
A6	1	0	1	0	0	1	1	0	V3+(V2-V3)*(1219.6/2090.8)	V11+(V10-V11)*(871.2/2090.8)
A7	1	0	1	0	0	1	1	1	V3+(V2-V3)*(1255.7/2090.8)	V11+(V10-V11)*(835.1/2090.8)
A8	1	0	1	0	1	0	0	0	V3+(V2-V3)*(1291.7/2090.8)	V11+(V10-V11)*(799.1/2090.8)
A9	1	0	1	0	1	0	0	1	V3+(V2-V3)*(1327.8/2090.8)	V11+(V10-V11)*(763.0/2090.8)
AA	1	0	1	0	1	0	1	0	V3+(V2-V3)*(1357.8/2090.8)	V11+(V10-V11)*(733.0/2090.8)
AB	1	0	1	0	1	0	1	1	V3+(V2-V3)*(1387.9/2090.8)	V11+(V10-V11)*(702.9/2090.8)
AC	1	0	1	0	1	1	0	0	V3+(V2-V3)*(1417.9/2090.8)	V11+(V10-V11)*(672.9/2090.8)
AD	1	0	1	0	1	1	0	1	V3+(V2-V3)*(1447.9/2090.8)	V11+(V10-V11)*(642.9/2090.8)
AE	1	0	1	0	1	1	1	0	V3+(V2-V3)*(1469.0/2090.8)	V11+(V10-V11)*(621.8/2090.8)
AF	1	0	1	0	1	1	1	1	V3+(V2-V3)*(1490.0/2090.8)	V11+(V10-V11)*(600.8/2090.8)
B0	1	0	1	1	0	0	0	0	V3+(V2-V3)*(1511.0/2090.8)	V11+(V10-V11)*(579.8/2090.8)
B1	1	0	1	1	0	0	0	1	V3+(V2-V3)*(1532.1/2090.8)	V11+(V10-V11)*(558.8/2090.8)
B2	1	0	1	1	0	0	1	0	V3+(V2-V3)*(1574.1/2090.8)	V11+(V10-V11)*(516.7/2090.8)
B3	1	0	1	1	0	0	1	1	V3+(V2-V3)*(1616.2/2090.8)	V11+(V10-V11)*(474.6/2090.8)
B4	1	0	1	1	0	1	0	0	V3+(V2-V3)*(1658.2/2090.8)	V11+(V10-V11)*(432.6/2090.8)
B5	1	0	1	1	0	1	0	1	V3+(V2-V3)*(1700.3/2090.8)	V11+(V10-V11)*(390.5/2090.8)
B6	1	0	1	1	0	1	1	0	V3+(V2-V3)*(1740.8/2090.8)	V11+(V10-V11)*(350.0/2090.8)
B7	1	0	1	1	0	1	1	1	V3+(V2-V3)*(1781.4/2090.8)	V11+(V10-V11)*(309.4/2090.8)
B8	1	0	1	1	1	0	0	0	V3+(V2-V3)*(1821.9/2090.8)	V11+(V10-V11)*(268.9/2090.8)
B9	1	0	1	1	1	0	0	1	V3+(V2-V3)*(1862.5/2090.8)	V11+(V10-V11)*(228.3/2090.8)
BA	1	0	1	1	1	0	1	0	V3+(V2-V3)*(1903.1/2090.8)	V11+(V10-V11)*(187.8/2090.8)
BB	1	0	1	1	1	0	1	1	V3+(V2-V3)*(1943.6/2090.8)	V11+(V10-V11)*(147.2/2090.8)
BC	1	0	1	1	1	1	0	0	V3+(V2-V3)*(1984.2/2090.8)	V11+(V10-V11)*(106.6/2090.8)
BD	1	0	1	1	1	1	0	1	V3+(V2-V3)*(2024.7/2090.8)	V11+(V10-V11)*(66.1/2090.8)
BE	1	0	1	1	1	1	1	0	V3+(V2-V3)*(2057.8/2090.8)	V11+(V10-V11)*(33.0/2090.8)
BF	1	0	1	1	1	1	1	1		

Hex	INPUT DATA								OUTPUT DATA	
	Dx7	Dx6	Dx5	Dx4	Dx3	Dx2	Dx1	Dx0	Positive	Negative
									V2	V11
C0	1	1	0	0	0	0	0	0	V2+(V1-V2)*(33.0/1231.7)	V12+(V11-V12)*(1198.6/1231.7)
C1	1	1	0	0	0	0	0	1	V2+(V1-V2)*(66.1/1231.7)	V12+(V11-V12)*(1165.6/1231.7)
C2	1	1	0	0	0	0	0	1	V2+(V1-V2)*(102.1/1231.7)	V12+(V11-V12)*(1129.5/1231.7)
C3	1	1	0	0	0	0	1	1	V2+(V1-V2)*(138.2/1231.7)	V12+(V11-V12)*(1093.5/1231.7)
C4	1	1	0	0	0	1	0	0	V2+(V1-V2)*(174.2/1231.7)	V12+(V11-V12)*(1057.4/1231.7)
C5	1	1	0	0	0	1	0	1	V2+(V1-V2)*(210.3/1231.7)	V12+(V11-V12)*(1021.4/1231.7)
C6	1	1	0	0	0	1	1	0	V2+(V1-V2)*(244.8/1231.7)	V12+(V11-V12)*(986.8/1231.7)
C7	1	1	0	0	0	1	1	1	V2+(V1-V2)*(279.4/1231.7)	V12+(V11-V12)*(952.3/1231.7)
C8	1	1	0	0	1	0	0	0	V2+(V1-V2)*(313.9/1231.7)	V12+(V11-V12)*(917.7/1231.7)
C9	1	1	0	0	1	0	0	1	V2+(V1-V2)*(348.5/1231.7)	V12+(V11-V12)*(883.2/1231.7)
CA	1	1	0	0	1	0	1	0	V2+(V1-V2)*(386.0/1231.7)	V12+(V11-V12)*(845.6/1231.7)
CB	1	1	0	0	1	0	1	1	V2+(V1-V2)*(423.6/1231.7)	V12+(V11-V12)*(808.1/1231.7)
CC	1	1	0	0	1	1	0	0	V2+(V1-V2)*(461.1/1231.7)	V12+(V11-V12)*(770.5/1231.7)
CD	1	1	0	0	1	1	0	1	V2+(V1-V2)*(498.7/1231.7)	V12+(V11-V12)*(733.0/1231.7)
CE	1	1	0	0	1	1	1	0	V2+(V1-V2)*(537.7/1231.7)	V12+(V11-V12)*(693.9/1231.7)
CF	1	1	0	0	1	1	1	1	V2+(V1-V2)*(576.8/1231.7)	V12+(V11-V12)*(654.9/1231.7)
D0	1	1	0	1	0	0	0	0	V2+(V1-V2)*(615.8/1231.7)	V12+(V11-V12)*(615.8/1231.7)
D1	1	1	0	1	0	0	0	1	V2+(V1-V2)*(654.9/1231.7)	V12+(V11-V12)*(576.8/1231.7)
D2	1	1	0	1	0	0	1	0	V2+(V1-V2)*(693.9/1231.7)	V12+(V11-V12)*(537.7/1231.7)
D3	1	1	0	1	0	0	1	1	V2+(V1-V2)*(733.0/1231.7)	V12+(V11-V12)*(498.7/1231.7)
D4	1	1	0	1	0	1	0	0	V2+(V1-V2)*(772.0/1231.7)	V12+(V11-V12)*(459.6/1231.7)
D5	1	1	0	1	0	1	0	1	V2+(V1-V2)*(811.1/1231.7)	V12+(V11-V12)*(420.6/1231.7)
D6	1	1	0	1	0	1	1	0	V2+(V1-V2)*(844.1/1231.7)	V12+(V11-V12)*(387.5/1231.7)
D7	1	1	0	1	0	1	1	1	V2+(V1-V2)*(877.2/1231.7)	V12+(V11-V12)*(354.5/1231.7)
D8	1	1	0	1	1	0	0	0	V2+(V1-V2)*(910.2/1231.7)	V12+(V11-V12)*(321.4/1231.7)
D9	1	1	0	1	1	0	0	1	V2+(V1-V2)*(943.3/1231.7)	V12+(V11-V12)*(288.4/1231.7)
DA	1	1	0	1	1	0	1	0	V2+(V1-V2)*(988.3/1231.7)	V12+(V11-V12)*(243.3/1231.7)
DB	1	1	0	1	1	0	1	1	V2+(V1-V2)*(1033.4/1231.7)	V12+(V11-V12)*(198.3/1231.7)
DC	1	1	0	1	1	1	0	0	V2+(V1-V2)*(1078.4/1231.7)	V12+(V11-V12)*(153.2/1231.7)
DD	1	1	0	1	1	1	0	1	V2+(V1-V2)*(1123.5/1231.7)	V12+(V11-V12)*(108.1/1231.7)
DE	1	1	0	1	1	1	1	0	V2+(V1-V2)*(1177.6/1231.7)	V12+(V11-V12)*(54.1/1231.7)
DF	1	1	0	1	1	1	1	1	V1+(V0-V1)*(54.1/5287.1)	13+(V12-V13)*(5233.0/5287.1)
E0	1	1	1	0	0	0	0	0	V1+(V0-V1)*(108.1/5287.1)	13+(V12-V13)*(5179.0/5287.1)
E1	1	1	1	0	0	0	0	1	V1+(V0-V1)*(162.2/5287.1)	13+(V12-V13)*(5124.9/5287.1)
E2	1	1	1	0	0	0	1	0	V1+(V0-V1)*(216.3/5287.1)	13+(V12-V13)*(5070.8/5287.1)
E3	1	1	1	0	0	0	1	1	V1+(V0-V1)*(270.4/5287.1)	13+(V12-V13)*(5016.7/5287.1)
E4	1	1	1	0	0	1	0	0	V1+(V0-V1)*(324.4/5287.1)	13+(V12-V13)*(4962.7/5287.1)
E5	1	1	1	0	0	1	0	1	V1+(V0-V1)*(383.0/5287.1)	13+(V12-V13)*(4904.1/5287.1)
E6	1	1	1	0	0	1	1	0	V1+(V0-V1)*(441.6/5287.1)	13+(V12-V13)*(4845.5/5287.1)
E7	1	1	1	0	0	1	1	1	V1+(V0-V1)*(500.2/5287.1)	13+(V12-V13)*(4786.9/5287.1)
E8	1	1	1	0	1	0	0	1	V1+(V0-V1)*(558.8/5287.1)	13+(V12-V13)*(4728.4/5287.1)
E9	1	1	1	0	1	0	1	0	V1+(V0-V1)*(623.3/5287.1)	13+(V12-V13)*(4663.8/5287.1)
EA	1	1	1	0	1	0	1	1	V1+(V0-V1)*(687.9/5287.1)	13+(V12-V13)*(4599.2/5287.1)
EB	1	1	1	0	1	0	1	1	V1+(V0-V1)*(752.5/5287.1)	13+(V12-V13)*(4534.6/5287.1)
EC	1	1	1	0	1	1	0	0	V1+(V0-V1)*(817.1/5287.1)	13+(V12-V13)*(4470.0/5287.1)
ED	1	1	1	0	1	1	0	1	V1+(V0-V1)*(899.7/5287.1)	13+(V12-V13)*(4387.4/5287.1)
EE	1	1	1	0	1	1	1	0	V1+(V0-V1)*(982.3/5287.1)	13+(V12-V13)*(4304.8/5287.1)
EF	1	1	1	0	1	1	1	1	V1+(V0-V1)*(1064.9/5287.1)	13+(V12-V13)*(4222.2/5287.1)
F0	1	1	1	1	0	0	0	0	V1+(V0-V1)*(1147.5/5287.1)	13+(V12-V13)*(4139.6/5287.1)
F1	1	1	1	1	0	0	0	1	V1+(V0-V1)*(1249.7/5287.1)	13+(V12-V13)*(4037.4/5287.1)
F2	1	1	1	1	0	0	1	0	V1+(V0-V1)*(1351.8/5287.1)	13+(V12-V13)*(3935.3/5287.1)
F3	1	1	1	1	0	0	1	1	V1+(V0-V1)*(1454.0/5287.1)	13+(V12-V13)*(3833.1/5287.1)
F4	1	1	1	1	0	1	0	0	V1+(V0-V1)*(1556.1/5287.1)	13+(V12-V13)*(3731.0/5287.1)
F5	1	1	1	1	0	1	1	0	V1+(V0-V1)*(1704.8/5287.1)	13+(V12-V13)*(3582.3/5287.1)
F6	1	1	1	1	0	1	1	1	V1+(V0-V1)*(1853.5/5287.1)	13+(V12-V13)*(3433.6/5287.1)
F7	1	1	1	1	1	0	0	0	V1+(V0-V1)*(2002.2/5287.1)	13+(V12-V13)*(3284.9/5287.1)
F8	1	1	1	1	1	0	0	1	V1+(V0-V1)*(2150.9/5287.1)	13+(V12-V13)*(3136.2/5287.1)
F9	1	1	1	1	1	0	1	0	V1+(V0-V1)*(2778.1/5287.1)	13+(V12-V13)*(2509.0/5287.1)
FA	1	1	1	1	1	0	1	1	V1+(V0-V1)*(3405.4/5287.1)	13+(V12-V13)*(1881.7/5287.1)
FB	1	1	1	1	1	1	0	0	V1+(V0-V1)*(4032.6/5287.1)	13+(V12-V13)*(1254.5/5287.1)
FC	1	1	1	1	1	1	0	1	V1+(V0-V1)*(4659.9/5287.1)	13+(V12-V13)*(627.2/5287.1)
FD	1	1	1	1	1	1	1	0	V0	V13
FE	1	1	1	1	1	1	1	0		
FF	1	1	1	1	1	1	1	1		

6.4 Gate Driver Timing Control

HX8227-A01 incorporates a timing controller to generate signals for the gate driver IC. HX8227-A01 outputs gate driver timing signals from CKV, STV, and OEV pins.

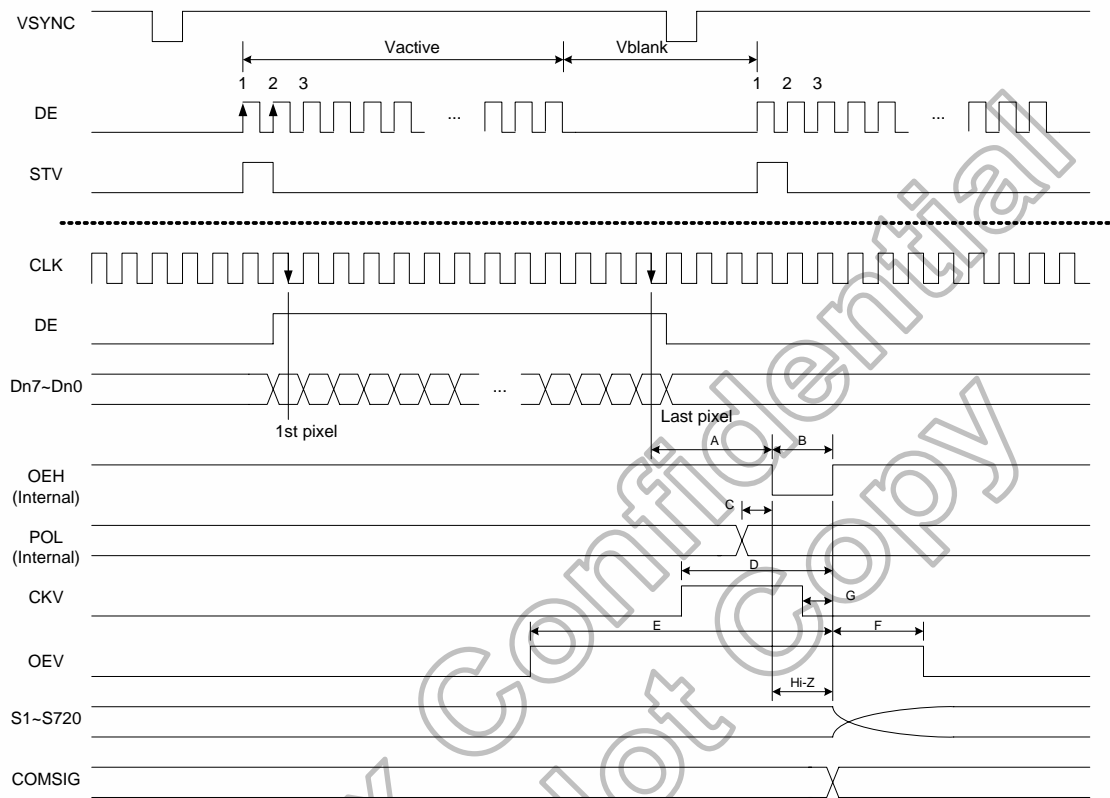

Figure 6. 7 Gate driver timing control

Timing	480RGBx272	480RGBx240	240RGBx320	240RGBx240
A	8	8	4	4
B	4	4	2	2
C	0	0	0	0
D	10	10	5	5
E	34	34	17	17
F	6	6	3	3
G	2	2	1	1

Unit: Clock

Table 6. 2 Relationship between resolution and output timing (parallel RGB)

Timing	480RGBx272	480RGBx240	240RGBx320	240RGBx240
A	24	24	12	12
B	12	12	6	6
C	0	0	0	0
D	30	30	15	15
E	102	102	51	51
F	18	18	9	9
G	6	6	3	3

Unit: Clock

Table 6. 3 Relationship between resolution and output timing (serial RGB)

6.5 Power ON/OFF Control

HX8227-A01 has a power ON/OFF sequence control function. When DISP pin is pulled “H”, blank data is outputted for 10-frames first, from the falling edge of the following VSYNC signal. Similarly, when DISP is pulled “L”, 10-frames of blank data will be outputted from the falling edge of the following VSYNC, too. The blank data would be gray level 0 for normally black LC (NBW=“H”), and be gray level 255 for normally white LC (NBW=“L”).

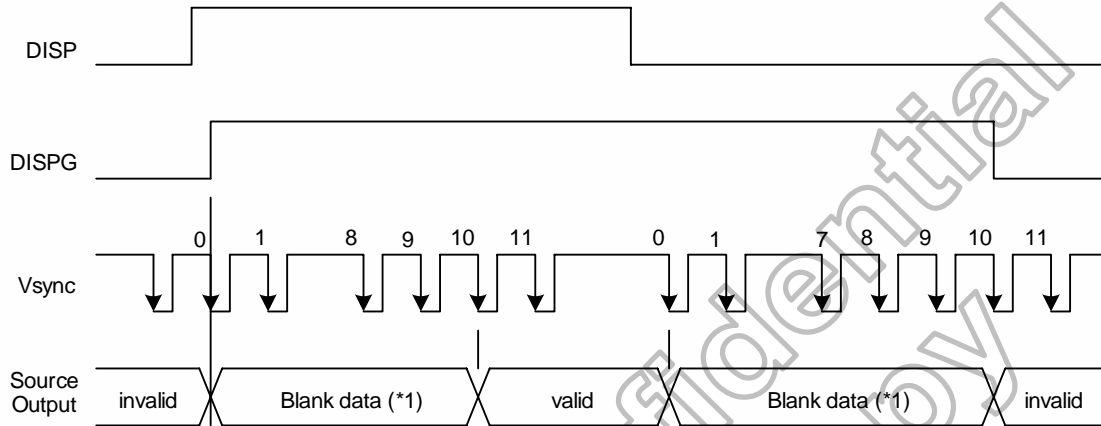

Figure 6. 8 Power on/off control

6.6 Reset

HX8227-A01 is internally initialized by the global reset signal, RESETB. The reset input must be held for at least 1ms after power is stable.

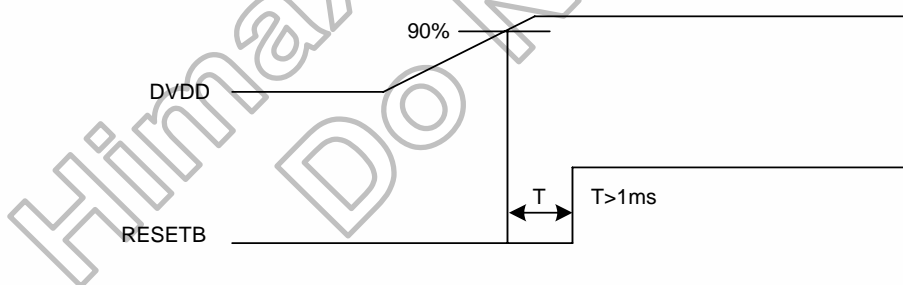

Figure 6. 9 Reset timing

7. DC Characteristics

7.1 Absolute maximum ratings

Parameter	Symbol	Spec.			Unit
		Min.	Typ.	Max.	
Logic power supply	DVDD	-0.3	-	6.0	V
Driver power supply	AVDD	-0.3	-	6.0	V
Logic input voltage	V _{I1}	-0.3	-	DVDD+0.3	V
Driver input voltage	V _{I2}	-0.3	-	AVDD+0.3	V
Logic output voltage	V _{O1}	-0.3	-	DVDD+0.3	V
Driver output voltage	V _{O2}	-0.3	-	AVDD+0.3	V
Operation ambient temperature	T _A	-30	-	85	°C
Storage temperature	T _{STG}	-40	-	125	°C

7.2 Recommended operating conditions (T_A = 25°C, DVSS = AVSS = 0V)

Parameter	Symbol	Spec.			Unit
		Min.	Typ.	Max.	
Logic power supply	DVDD	2.25	2.5	3.6	V
Driver power supply	AVDD	4.8	5.0	5.2	V
Input high voltage	V _{IH}	0.7DVDD	-	DVDD	V
Input low voltage	V _{IL}	0	-	0.3DVDD	V
Driver output voltage	V _O	0.2	-	AVDD-0.2	V
Gamma voltage	V _N	0.2	-	AVDD-0.2	V
Clock frequency	f _{CLK} ⁽¹⁾	-	9	15	MHz

Note: (1) For parallel RGB interface, maximum clock frequency is 15MHz. For serial RGB interface, the maximum clock frequency is 33MHz.

7.3 Electrical Characteristics

(T_A=25°C, DVDD=2.25V to 3.6V, AVDD=4.8V to 5.2V, DVSS=AVSS=0V)

Parameter	Symbol	Condition	Spec.			Unit
			Min.	Typ.	Max.	
Input low leakage current	I _{IL}	No pull-up or pull-down	-1	-	1	μA
Input high leakage current	I _{IH}	No pull-up or pull-down	-1	-	1	μA
Output low voltage	V _{OL} ⁽¹⁾	I _{OL} =1mA	DVSS	-	DVSS+0.4	V
Output high voltage	V _{OH} ⁽¹⁾	I _{OH} =-1mA	DVDD-0.4	-	DVDD	V
Gamma resistor	R _{GMA}	AVDD=5V, T _A =25°C, V _O to V _n =4V	-	17.1	-	kΩ
Driver output current	I _{VOL}	AVDD=5V, V _O =0.2V, V _{IN} =0.7V	-	-	80	μA
	I _{VOH}	AVDD=5V, V _O =4.8V, V _{IN} =4.3V	80	-	-	μA
Average output deviation (chip to chip)	ΔV _d	Center Gary level	-	-	10	mV
Output deviation	ΔV _{O1}	V _O =1.5V to AVDD-1.5V	-	±10	±15	mV
Output deviation	ΔV _{O2}	V _O < 1.5V or > AVDD-1.5V	-	±20	±40	mV
Logic dynamic current	I _{DD1}	DVDD	-	1.0 ⁽²⁾	2.0 ⁽³⁾	mA
Driver dynamic current	I _{DD2}	AVDD	-	8.75 ⁽⁴⁾	10 ⁽⁵⁾	mA
Input pull up/down resistance	R _I	V _{IL} = 0V or V _{IH} = DVDD	150	-	-	kΩ

Note: (1) CKV, STV, OEV pins

(2) Parallel interface, f_{CLK}=9MHz, f_{STB}=17.14KHz, dot inversion pattern, DVDD=2.5V, T_A=25°C

(3) Parallel interface, f_{CLK}=9MHz, f_{STB}=17.14KHz, dot inversion pattern, DVDD=2.75V, T_A=-30 to 85°C

(4) Parallel interface, f_{CLK}=9MHz, f_{STB}=17.14KHz, all white (NBW="H") pattern, AVDD=5V, V_O=4.5V, V_n=0.2V, T_A=25°C

(5) Parallel interface, f_{CLK}=9MHz, f_{STB}=17.14KHz, all white (NBW="H") pattern, AVDD=5.2V, V_O=4.5V, V_n=0.2V, T_A=-30 to 85°C

8. AC Characteristics

8.1 Switching characteristics

($T_A=25^\circ\text{C}$, $DVDD=2.25\text{V}$ to 3.6V , $AVDD=4.8\text{V}$ to 5.2V , $DVSS=AVSS=0\text{V}$)

PARAMETER	Symbol	Spec.			Unit
		Min.	Typ.	Max.	
Logic output delay time	$T_{PLH}^{(1)}$	-	-	50	ns
Driver output delay time	$T_{PLH2}^{(2)}$	-	-	10	μs
	$T_{PLH3}^{(3)}$	-	-	12	μs
	$T_{PHL2}^{(2)}$	-	-	10	μs
	$T_{PHL3}^{(3)}$	-	-	12	μs
	Input Capacitance	C_{I1}	-	-	10

Note: (1) CLK edge to CKV, STV, OEV and COMSIG pins, $C_L = 15\text{pF}$

(2) Specified when driver voltage reaches 10% or 90% of the target level. $R_L=17\text{ k}\Omega$, $C_L=40\text{pF}$, $DVDD=2.5\text{V}$, $AVDD=5\text{V}$.

(3) Specified when driver voltage reaches 6-bit accuracy of the target level. $R_L=17\text{ k}\Omega$, $C_L=40\text{pF}$, $DVDD=2.5\text{V}$, $AVDD=5\text{V}$.

Himax Confidential
Do Not Copy

8.2 Parallel RGB Input Timing Requirement

(480RGBx272, T_A=25°C, DVDD=2.25V to 3.6V, DVSS= 0V)

PARAMETER	Symbol	Spec.			Unit
		Min.	Typ.	Max.	
Clock cycle	f _{CLK} ⁽¹⁾	-	9	15	MHz
Hsync cycle	1/th	-	17.14	-	KHz
Vsync cycle	1/tv	-	59.94	-	Hz
Horizontal Signal					
Horizontal cycle	th	-	525	-	CLK
Horizontal display period	thd	-	480	-	CLK
Horizontal front porch	thf	2	-	-	CLK
Horizontal pulse width	thp	2	41	-	CLK
Horizontal back porch	thb	2	2	-	CLK
Vertical Signal					
Vertical cycle	tv	-	286	-	H
Vertical display period	tvd	-	272	-	H
Vertical front porch	tvf	1	2	-	H
Vertical pulse width	tvp	1	10	-	H
Vertical back porch	tvb	1	2	-	H

Note: (1) Unit: CLK=1/ f_{CLK}, H=th

(480RGBx240, T_A=25°C, DVDD=2.25V to 3.6V, DVSS= 0V)

PARAMETER	Symbol	Spec.			Unit
		Min.	Typ.	Max.	
Clock cycle	f _{CLK} ⁽¹⁾	-	9.6	15	MHz
Hsync cycle	1/th	-	15.72	-	KHz
Vsync cycle	1/tv	-	60	-	Hz
Horizontal Signal					
Horizontal cycle	th	-	612	-	CLK
Horizontal display period	thd	-	480	-	CLK
Horizontal front porch	thf	2	30	-	CLK
Horizontal pulse width	thp	2	46	-	CLK
Horizontal back porch	thb	2	56	-	CLK
Vertical Signal					
Vertical cycle	tv	-	262	-	H
Vertical display period	tvd	-	240	-	H
Vertical front porch	tvf	1	4	-	H
Vertical pulse width	tvp	1	3	-	H
Vertical back porch	tvb	1	15	-	H

Note: (1) Unit: CLK=1/ f_{CLK}, H=th

(240RGBx320, T_A=25°C, DVDD=2.25V to 3.6V, DVSS= 0V)

PARAMETER	Symbol	Spec.			Unit
		Min.	Typ.	Max.	
Clock cycle	f _{CLK} ⁽¹⁾	-	5.5	15	MHz
Hsync cycle	1/th	-	19.56	-	KHz
Vsync cycle	1/tv	-	60	-	Hz
Horizontal Signal					
Horizontal cycle	th	-	280	-	CLK
Horizontal display period	thd	-	240	-	CLK
Horizontal front porch	thf	2	23	-	CLK
Horizontal pulse width	thp	2	10	-	CLK
Horizontal back porch	thb	2	7	-	CLK
Vertical Signal					
Vertical cycle	tv	-	326	-	H
Vertical display period	tvd	-	320	-	H
Vertical front porch	tvf	1	2	-	H
Vertical pulse width	tvp	1	2	-	H
Vertical back porch	tvb	1	2	-	H

Note: (1) Unit: CLK=1/ f_{CLK}, H=th

(240RGBx240, T_A=25°C, DVDD=2.25V to 3.6V, DVSS= 0V)

PARAMETER	Symbol	Spec.			Unit
		Min.	Typ.	Max.	
Clock cycle	f _{CLK}	-	4.8	15	MHz
Hsync cycle	1/th	-	15.72	-	KHz
Vsync cycle	1/tv	-	60	-	Hz
Horizontal Signal					
Horizontal cycle	th	-	306	-	CLK
Horizontal display period	thd	-	240	-	CLK
Horizontal front porch	thf	2	15	-	CLK
Horizontal pulse width	thp	2	23	-	CLK
Horizontal back porch	thb	2	28	-	CLK
Vertical Signal					
Vertical cycle	tv	-	262	-	H
Vertical display period	tvd	-	240	-	H
Vertical front porch	tvf	1	4	-	H
Vertical pulse width	tvp	1	3	-	H
Vertical back porch	tvb	1	15	-	H

Note: (1) Unit: CLK=1/ f_{CLK}, H=th

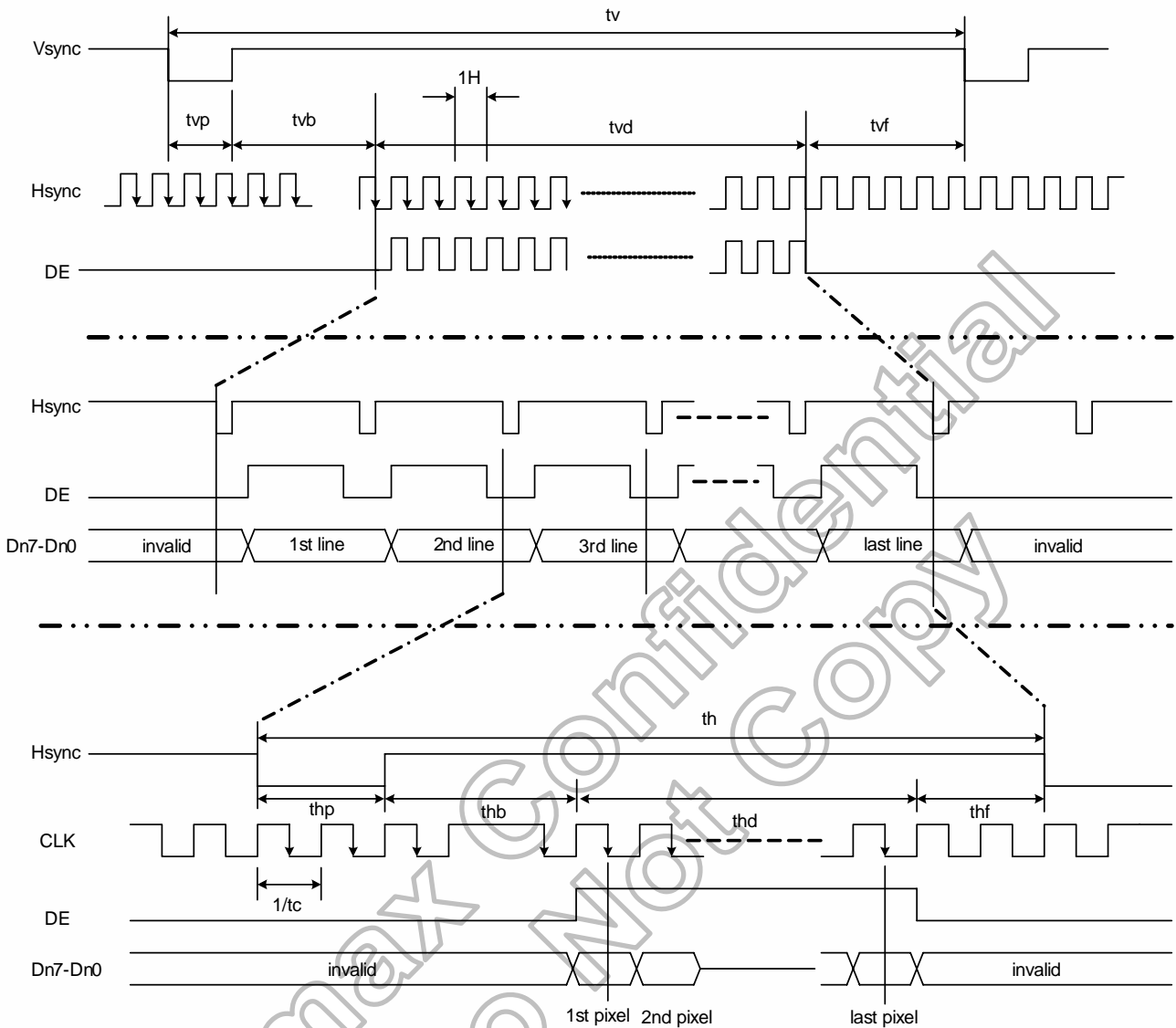

Figure 8.1 Parallel RGB Input timing

8.3 Serial RGB Input Timing Requirement

(480RGBx272, T_A=25°C, DVDD=2.25V to 3.6V, DVSS= 0V)

PARAMETER	Symbol	Spec.			Unit
		Min.	Typ.	Max.	
Clock cycle	f _{CLK} ⁽¹⁾	-	27	33	MHz
Hsync cycle	1/th	-	17.14	-	KHz
Vsync cycle	1/tv	-	59.94	-	Hz
Horizontal Signal					
Horizontal cycle	th	-	1575	-	CLK
Horizontal display period	thd	-	1440	-	CLK
Horizontal front porch	thf	6	-	-	CLK
Horizontal pulse width	thp	6	123	-	CLK
Horizontal back porch	thb	2	6	-	CLK
Vertical Signal					
Vertical cycle	tv	-	286	-	H
Vertical display period	tvd	-	272	-	H
Vertical front porch	tvf	1	2	-	H
Vertical pulse width	tvp	1	10	-	H
Vertical back porch	tvb	1	2	-	H

Note: (1) Unit: CLK=1/ f_{CLK}, H=th

(480RGBx240, T_A=25°C, DVDD=2.25V to 3.6V, DVSS= 0V)

PARAMETER	Symbol	Spec.			Unit
		Min.	Typ.	Max.	
Clock cycle	f _{CLK} ⁽¹⁾	-	28.8	33	MHz
Hsync cycle	1/th	-	15.72	-	KHz
Vsync cycle	1/tv	-	60	-	Hz
Horizontal Signal					
Horizontal cycle	th	-	612	-	CLK
Horizontal display period	thd	-	480	-	CLK
Horizontal front porch	thf	6	90	-	CLK
Horizontal pulse width	thp	6	138	-	CLK
Horizontal back porch	thb	6	168	-	CLK
Vertical Signal					
Vertical cycle	tv	-	262	-	H
Vertical display period	tvd	-	240	-	H
Vertical front porch	tvf	1	4	-	H
Vertical pulse width	tvp	1	3	-	H
Vertical back porch	tvb	1	15	-	H

Note: (1) Unit: CLK=1/ f_{CLK}, H=th

(240RGBx320, T_A=25°C, DVDD=2.25V to 3.6V, DVSS= 0V)

PARAMETER	Symbol	Spec.			Unit
		Min.	Typ.	Max.	
Clock cycle	f _{CLK} ⁽¹⁾	-	16.5	33	MHz
Hsync cycle	1/th	-	19.56	-	KHz
Vsync cycle	1/tv	-	60	-	Hz
Horizontal Signal					
Horizontal cycle	th	-	840	-	CLK
Horizontal display period	thd	-	720	-	CLK
Horizontal front porch	thf	6	69	-	CLK
Horizontal pulse width	thp	6	30	-	CLK
Horizontal back porch	thb	6	21	-	CLK
Vertical Signal					
Vertical cycle	tv	-	326	-	H
Vertical display period	tvd	-	320	-	H
Vertical front porch	tvf	1	2	-	H
Vertical pulse width	tvp	1	2	-	H
Vertical back porch	tvb	1	2	-	H

Note: (1) Unit: CLK=1/ f_{CLK}, H=th

(240RGBx240, T_A=25°C, DVDD=2.25V to 3.6V, DVSS= 0V)

PARAMETER	Symbol	Spec.			Unit
		Min.	Typ.	Max.	
Clock cycle	f _{CLK} ⁽¹⁾	-	14.4	33	MHz
Hsync cycle	1/th	-	15.72	-	KHz
Vsync cycle	1/tv	-	60	-	Hz
Horizontal Signal					
Horizontal cycle	th	-	918	-	CLK
Horizontal display period	thd	-	720	-	CLK
Horizontal front porch	thf	6	45	-	CLK
Horizontal pulse width	thp	6	69	-	CLK
Horizontal back porch	thb	6	84	-	CLK
Vertical Signal					
Vertical cycle	tv	-	262	-	H
Vertical display period	tvd	-	240	-	H
Vertical front porch	tvf	1	4	-	H
Vertical pulse width	tvp	1	3	-	H
Vertical back porch	tvb	1	15	-	H

Note: (1) Unit: CLK=1/ f_{CLK}, H=th

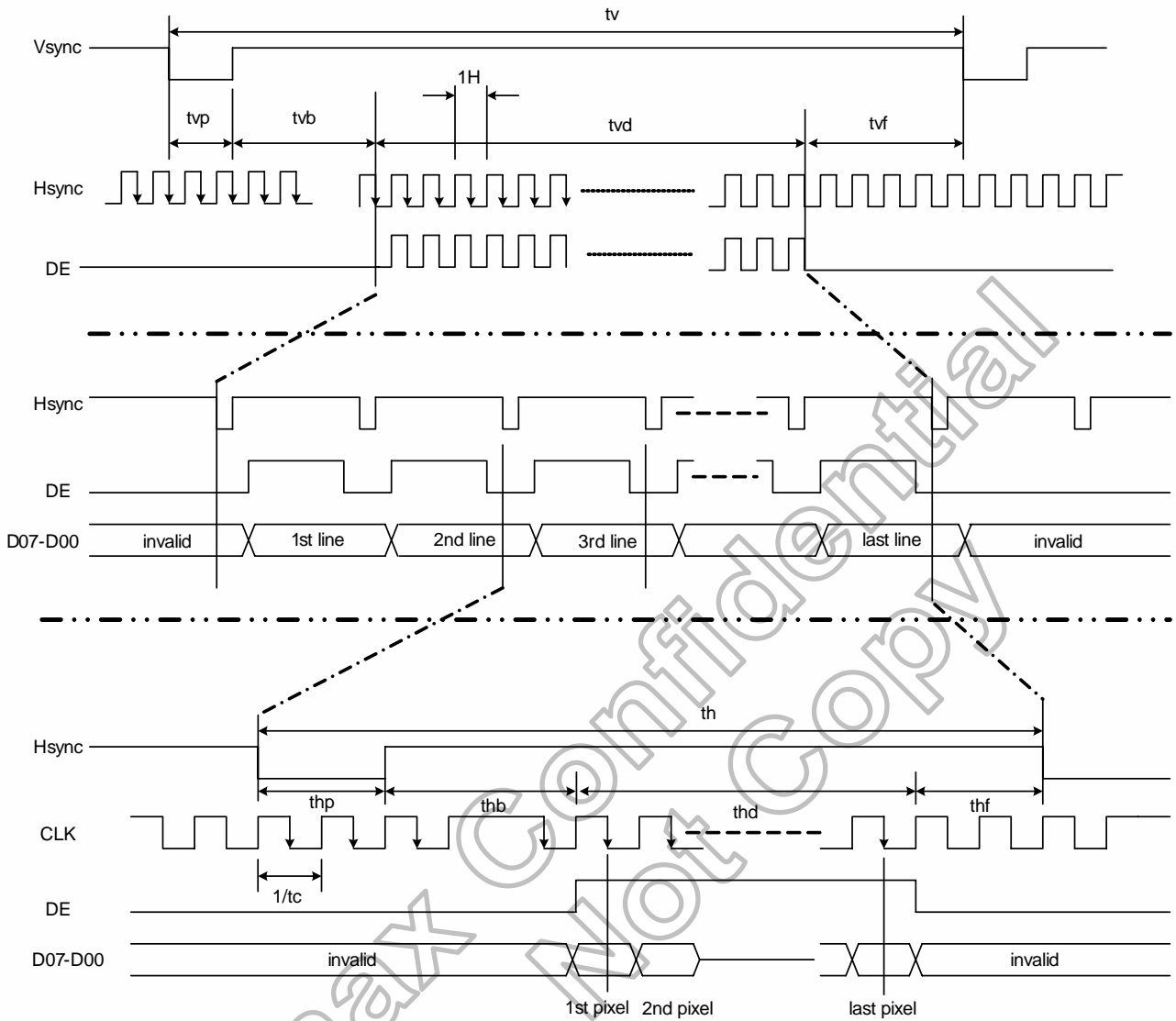

Figure 8.2 Serial RGB Input timing

8.4 Input Setup Timing Requirement

($T_A=25^\circ\text{C}$, $DVDD=2.25\text{V to }3.6\text{V}$, $DVSS=0\text{V}$, $t_r^{(1)}=t_f^{(1)}=2\text{ns}$)

PARAMETER	Symbol	Spec.			Unit
		Min.	Typ.	Max.	
DISP setup time	t_{diss}	10	-	-	ns
DISP hold time	t_{dish}	10	-	-	ns
Clock period	$PW_{CLK}^{(2)}$	66.7	-	-	ns
Clock pulse high period	$PWH^{(2)}$	26.7	-	-	ns
Clock pulse low period	$PWL^{(2)}$	26.7	-	-	ns
Hsync setup time	t_{hs}	10	-	-	ns
Hsync hold time	t_{hh}	10	-	-	ns
Data setup time	t_{ds}	10	-	-	ns
Data hold time	t_{dh}	10	-	-	ns
DE setup time	t_{des}	10	-	-	ns
DE hold time	t_{deh}	10	-	-	ns
Vsync setup time	t_{vhs}	10	-	-	ns
Vsync hold time	t_{vhh}	10	-	-	ns

Note: (1) t_r , t_f is defined 10% to 90% of signal amplitude.
 (2) For parallel interface, maximum clock frequency is 15MHz.

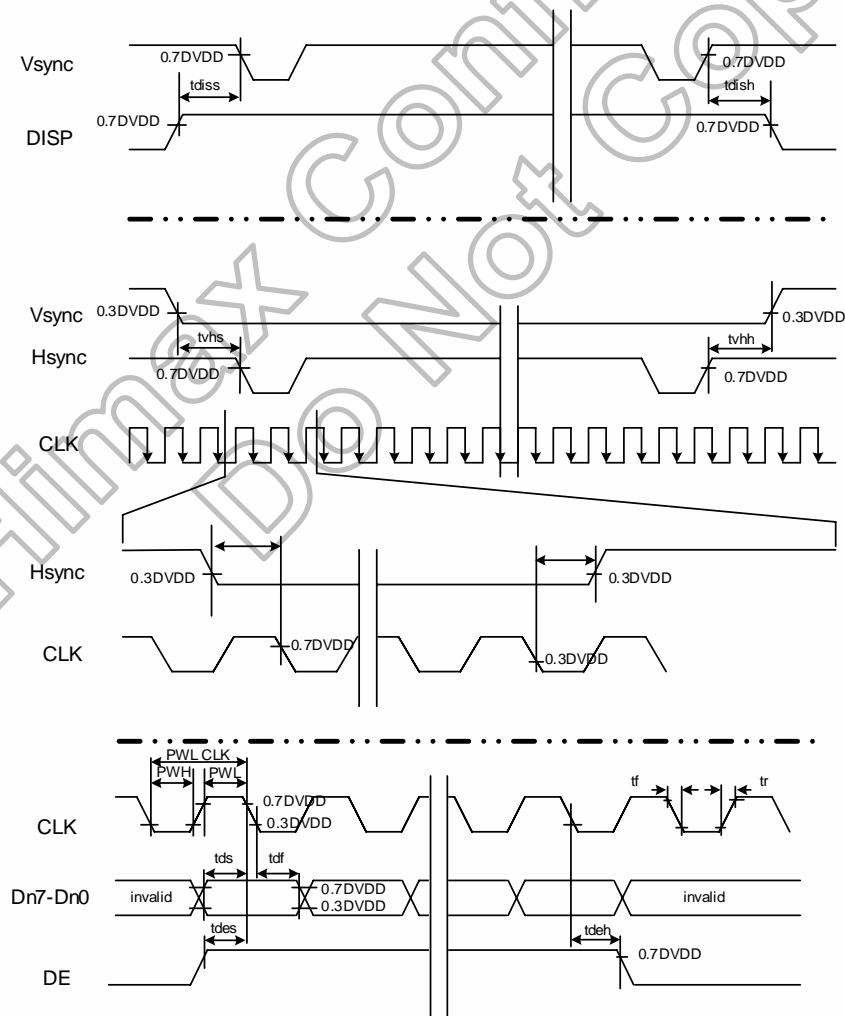

Figure 8. 3 Input setup timing

9. Ordering Information

Part NO.	Package
HX8227-A010PDxxx	PD : mean COG xxx : mean chip thickness (μm) , (default 400 μm)

10. Revision History

Version	EFF.DATE	DESCRIPTION OF CHANGES
01	2005/03/28	New setup
	2005/04/08	1. Add new resolutions: 240RGBx320 and 240RGBx240 2. Add new pin RES2 to select new extra resolution
	2005/04/26	1. Update: PAD location table 2. Update: Section 6.3 timing
	2005/06/08	1. Update: AC spec about serial RGB interface 2. Update: DC spec max VDD 2.75V 3. Update: Charge pump clock optional function 4. Update: MS and LR optional function
	2005/07/12	1. Update : Block Diagram(P.2) 2. Update : PAD location table(P.5) 3. Update : Driver dynamic current value(P.30)
02	2005/07/29	1. Update : PAD location table(P.5)
	2005/10/26	1. Modify figure 8.1 input timing 2. Modify figure 8.2 input setup timing
	2005/11/07	1. Modify figure 6. 8 power on/off control
03	2005/12/09	1. Modify "Pad layout coordinate" NO. 6, 7, 50, 56, 81, and 87 x pitch
	2005/12/16	1. Page 15 pin CLK_TRIG description modifies (CLKIN to CLK.) 2. Modify figure 8. 4 Thd
	2006/02/08	1. Update: DC spec max VDD 3.6V
	2006/02/20	1. Adding driver dynamic current in page 30 2. Modify Fig. 4.1 pad location
04	2006/03/15	1. Modify for new part HX8227-A01 2. Modify pin description TEST_IO1 and TEST_IO3 (P.16) 3. Modify Ladder resistors ratio and Input data and output voltage (P.22~P.26). 4. Removed 'preliminary' wording from the data sheet. 5. Update the unit $CLK=1/f_{CLK}$ & $H=th$ in section 8.2.(P.32~P.35)

Version	EFF.DATE	DESCRIPTION OF CHANGES
05	2006/08/14	1. Update figure 4.1 test I/O pin.(P.3) 2. Modify 6.3 source driver function, adding the descriptions of external Gamma reference voltage and gray-scale.(P.20)
	2006/11/06	1. Removed descriptions of TEST I/O 1, 3, 4 charge pump clock.(P.16) 2. Removed Table 6.2 IMS value and updated the example of 480 x 272 control setting figure. (P.17&P.19) 3. Updated section 8.3 serial RGB timing requirement. (P.35~P.37)

Himax Confidential
Do Not Copy