

• HXO-36&37&39 Series 7.0X5.0X1.5 mm

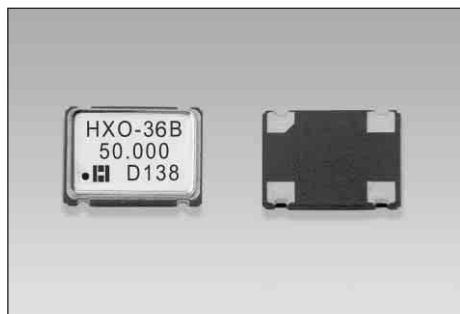

The HXO-36&37&39 series is an ultra miniature package clock oscillator with size of 7.0X5.0X1.5mm. It is mainly used in portable PC and telecommunication devices and equipment.

FEATURES

- Miniature Package
- Tri-State Enable/Disable
- TTL/HCMOS compatible
- Tape and Reel
- IR Re-flow
- 3.3V Input Voltage
- 2.5V&1.8V Option

Electrical Specifications

Parameter	Condition	HXO-36	HXO-37	HXO-39
Frequency Range	F _O	1MHz~125.00MHz		
Frequency Stability*	All Condition*	± 25ppm, ± 50ppm, ± 100ppm		
Operating Temperature Range	T _{OPR}	0°C~70°C(-40°C~+85°C option)		
Storage Temperature Range	T _{STG}	-55°C~+125°C		
Power supply Voltage	V _{DD}	3.3V+/-10%	1.8V+/-10%	2.5V+/-10%
Aging(First Year)	25°C ± 3°C	± 5ppm		
Supply Current	I _{DD}	1.000MHz to 23.999MHz	15mA Max	10mA Max
		24.000MHz to 49.999MHz	20mA Max	12mA Max
		50.000MHz to 69.999MHz	30mA Max	15mA Max
		70.000MHz to 125.000MHz	45mA Max	25mA Max
Output Symmetry	Sym	At 1/2V _{DD} 40/60%(45/55% Option)		
Rise time	T _r	10%V _{DD} ~90%V _{DD}	8 nS Max	6 nS Max
Fall Time	T _f	90%V _{DD} ~10%V _{DD}	8 nS Max	6 nS Max
Output Voltage	V _{OH}	90% V _{DD} min		
	V _{OL}	10% V _{DD} max		
Output Load	HCMOS Load	30pF Max(15pF type)		
Start-up Time	T _s	10mS Max		
Pin 1,tri-state function		Pin 1=H or open....Output active at pin 3 Pin 1=L.....high impedance at pin 3		

SMD Clock Oscillator

*Include: 25°C tolerance, operating temperature range, input voltage change, aging, load change, shock and vibration

Mechanical Dimensions(mm)

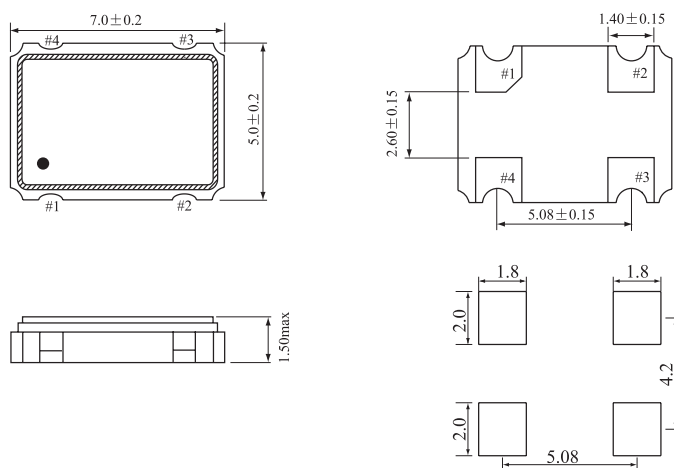

Pin	Connection
#1	Tri-State/NC
#2	GND
#3	Output
#4	+3.3V _{DC} (2.5V&1.8V)

Recommended Solder Pattern

**Note: A 0.01uF bypass capacitor should be placed between V_{DD}(Pin4) and GND(Pin2) to Minimize power supply line noise

TAIWAN:

HOSONIC ELECTRONIC CO., LTD.
23-1 LANE 84. CHUN YING ST. SHULIN CHEN.

TAIPEI 23804, TAIWAN
www.DataSheet4U.com
www.hosonic.com.tw

☎ : 886-2-86875200

☎ : 886-2-26816456

✉ : david@hosonic.com.tw

CHINA:

HANGZHOU HOSONIC ELECTRONIC CO., LTD.
NO.122 LIANGBO ROAD. LIANGZHU TOWN.
YUHANG DISTRICT, HANGZHOU, ZHEJIANG, CHINA
WEB SITE: <http://www.hosonic.com.cn>

☎ : (86)-571-88778189

☎ : (86)-571-88778857

✉ : market@hosonic.com.cn