

OUTLINE DIMENSIONS

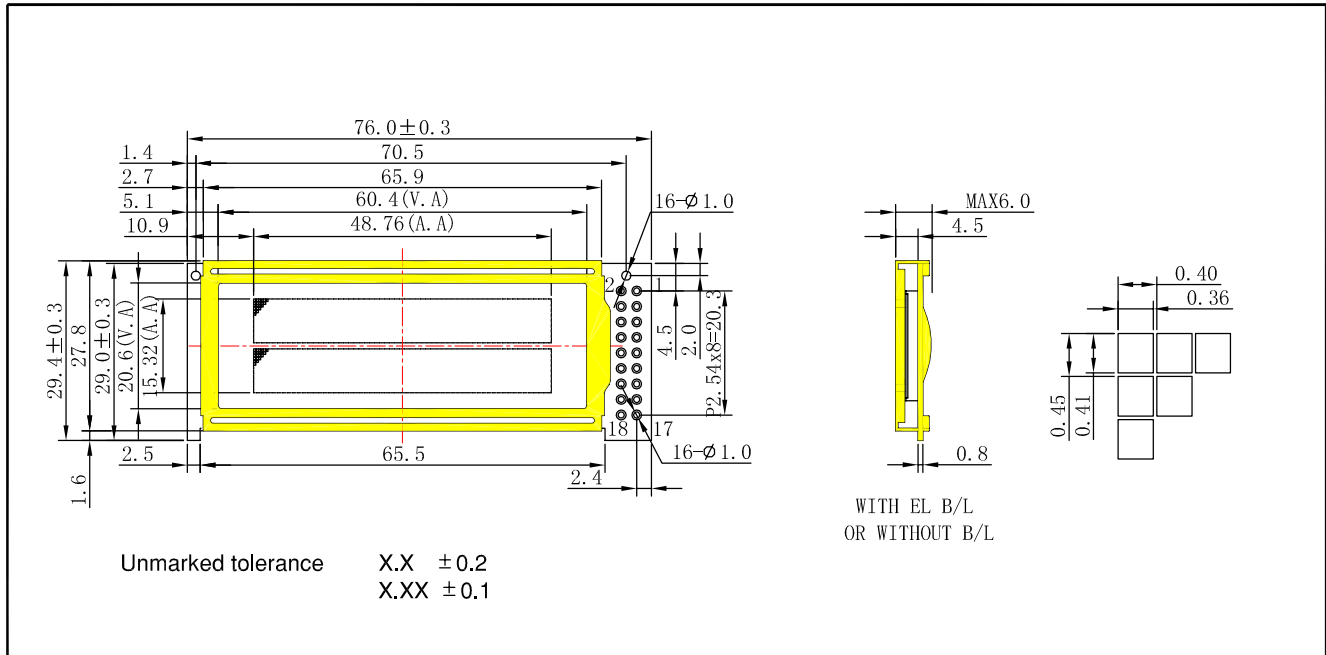

BLOCK DIAGRAM & POWER SUPPLY

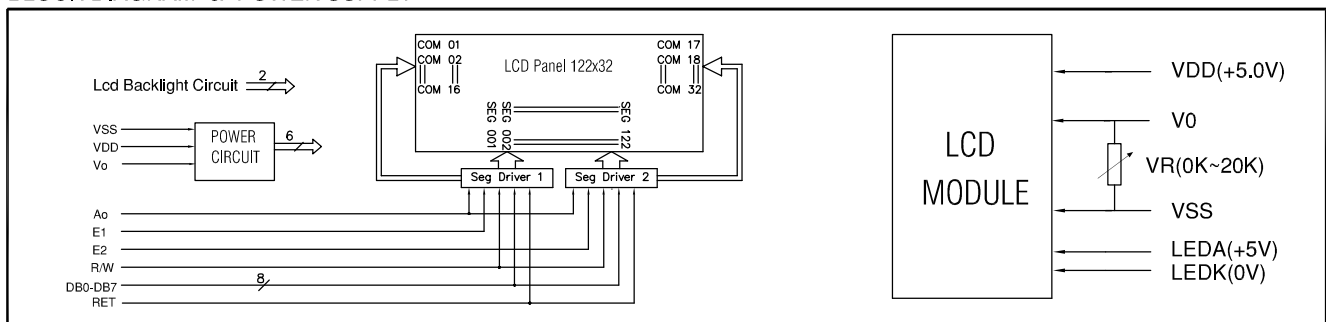

MECHANICAL SPECIFICATIONS & FEATURE

Item	Normal Dimensions(mm)	FEATURE	
Module Size (W*H*T)	76.0x29.4x6.0	LCD Type	STN、FSTN
View Area (W*H)	60.4x20.6	LCD Colour	STN:Yellow-Green、Gray FSTN:Gray
DotsxDots (W*H)	122x32	View Angle	6 O'clock、12 O'clock
Dot Pitch (W*H)	0.40x0.45	Display Type	Positive Type、Negative Type
Dot Size (W*H)	0.36x0.41	Rear polarizer	Transmissive、Reflective、Transflective
--	--	Operating Temperature	0°C ~ 50°C、-20°C ~ 70°C
--	--	Backlight	EL:Green、Blue-Green、Blue Without

ELECTRICAL CHARACTERISTICS

Item	Symbol	Test Condition	Min.	Typ.	Max.	Unit
Operating Voltage	Vdd	Ta=25° C	---	5.0	---	V
Operating Voltage for LCD	Vlcd	Ta=25° C	---	4.8	---	V
Supply Current	Idd	Ta=25° C, Vdd=5.0V	---	2.0	3.0	mA
Supply Current for Backlight(EL)	If	Ta=25° C, Vf=5.0V	10	35	---	mA

INTERFACE PIN CONNECTIONS

Pin No	Symbol	Level	Description
1	VDD	--	Power supply for Logic(+5.0V)
2	VSS	--	Ground for Logic
3	Vo	--	Power supply for LCD drive
4	/RST	L	Reset signal
5	E1	H/H→ L	Enable signal for IC1(left half of the panel)
6	E2	H/H→ L	Enable signal for IC2(right half of the panel)
7	R/W	H/L	Read/write selection (H:Read,L:Write)
8	RS	H/L	Register selection (H:Data register, L:Instruction register)
8-16	DB0-DB7	H/L	Data Bus lines
17	EL	--	Backlight driver connect
18	NC	--	No connection

REMARK

Operating voltage option:5.0V or 3.0V
Negative type LCD colour: Blue