



GEMINI Technology Co., Ltd.
www.FindLCD.com

SPECIFICATION FOR LCM MODULE

MODULE NO.: HY-1602E-201-R
DOC.REVISION 00

Customer Approval:

--

	SIGNATURE	DATE
PREPARED BY (RD ENGINEER)		May-22-2006
PREPARED BY (QA ENGINEER)		
CHECKED BY		
APPROVED BY		



DOCUMENT REVISION HISTORY

Version	DATE	DESCRIPTION	CHANGED BY
00	May-22-2006	First issue	



CONTENTS

1. Functions & Features	1
2. Mechanical specifications	1
3. Block diagram	1
4. Dimensional Outline	2
5. Pin description	2
6. Maximum absolute limit	3
7. Electrical characteristics	4-6
8. Control and display command	7
9. Backlight drawing & specification	8
10. Electro-Optical characteristics	8
11. Font characteristics	9
12. Quality Specifications	10~18

1. FUNCTIONS & FEATURES

- | | |
|--|--|
| 1.1. Format | : 16x2 characters |
| 1.2. LCD mode | : STN / Transflective Positive Mode / Yellow-Green |
| 1.3. Viewing direction | : 6 o'clock |
| 1.4. Driving scheme | : 1/16 Duty, 1/5 Bias |
| 1.5. Power supply voltage (V _{DD}) | : 5.0V |
| 1.6. LCD driving voltage(V _{op}) | : 5.0V |
| 1.7. Operation temp | : -20~70 |
| 1.8. Storage temp | : -30~80 |
| 1.9. Backlight color | : Yellow-Green |
| 1.10. RoHS | |

2. MECHANICAL SPECIFICATIONS

- | | |
|----------------------|--------------------------------------|
| 2.1. Module size | : 122.0mm(L)*44.0mm(W)*13.0 mm(H)max |
| 2.2. Viewing area | : 99.0mm(L)*25.0mm(W) |
| 2.3. Character pitch | : 6.0mm(L)*10.34mm(W) |
| 2.4. Character size | : 4.84mm(L)x9.66mm(W) |
| 2.5. Dot pitch | : 0.98mm(L)*1.16mm(W) |
| 2.6. Dot size | : 0.92mm(L)*1.10mm(W) |
| 2.7. Weight | : Approx. |

3. BLOCK DIAGRAM

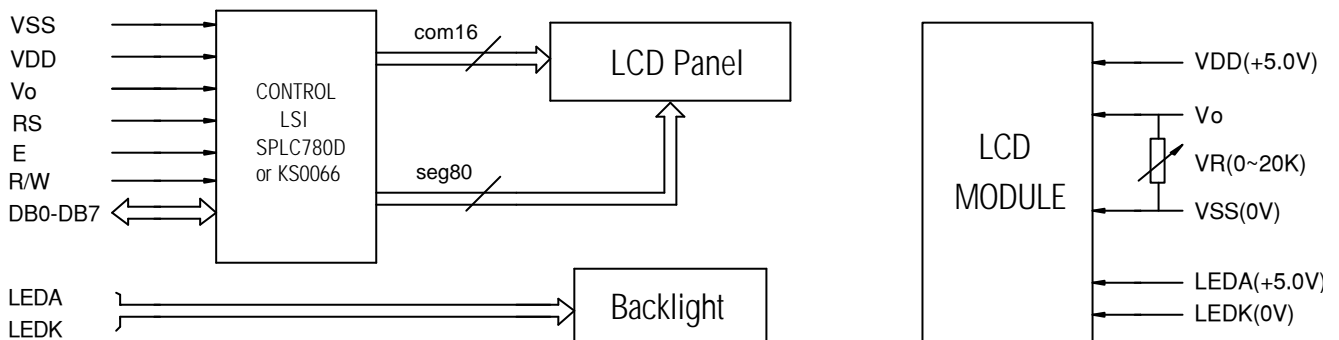

Figure 1. Block diagram

4. DIMENSIONAL OUTLINE

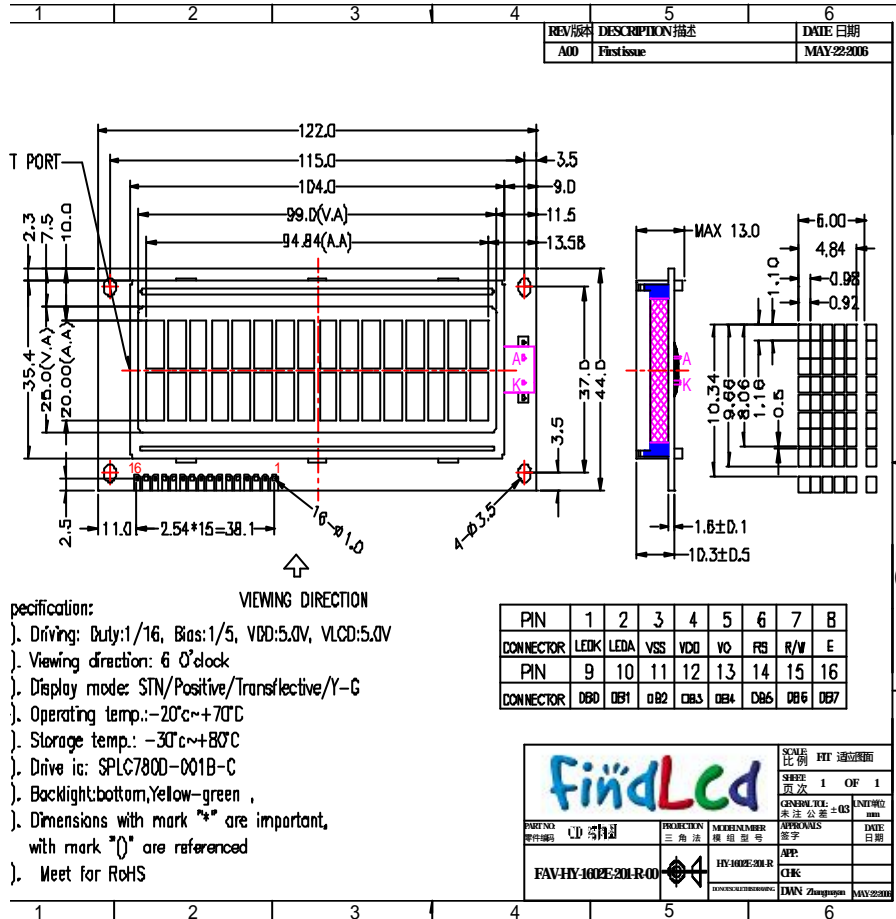

Figure 2. Dimensional outline

5. PIN DESCRIPTION

No.	Symbol	Function
1	LEDK	Power supply for Backlight(0V)
2	LEDA	Power supply for Backlight(+5.0V)
3	VSS	GND(0V)
4	VDD	Power supply for Logic(+5.0V)
5	VO	Power supply for LCD drive
6	RS	Register selection (H: Data register , L :Instruction register)
7	R/W	Read/write selection (H: Read , L: Write)
8	E	Enable signal for LCM
9~16	DB0~DB7	Data Bus lines

6. MAXIMUM ABSOLUTE LIMIT

Maximum Absolute Power Ratings

Characteristic	Symbol	Unit	Value
Power Supply Voltage(1)	V_{DD}	V	-0.3 ~ +7.0
Power Supply Voltage(2)	V_{LCD}	V	$V_{DD}-15.0 \sim V_{DD}+0.3$
Input Voltage	V_{IN}	V	-0.3 ~ $V_{DD}+0.3$

NOTE: Voltage greater than above may damage the circuit.

$V_{DD} > V_1 > V_2 > V_3 > V_4 > V_5$

Temperature characteristics

Characteristic	Symbol	Unit	Value
Operating Temperature	T_{OPR}	°C	-30 ~ +85
Storage Temperature	T_{STG}	°C	-55 ~ +125

7. ELECTRICAL CHARACTERISTICS

1.DC CHARACTERISTICS

(VDD = 4.8V ~ 5.5V, Ta = 25)

Characteristic	Symbol	Condition	Min.	Typ.	Max.	Unit
Operating Voltage	V _{DD}	-	4.8	-	5.5	V
Supply Current	I _{DD}	Internal oscillation or external clock. (V _{DD} =5.0 V, fosc = 270 kHz)	-	0.35	0.6	mA
Input Voltage (1) (except OSC1)	V _{IH1}	-	2.2	-	V _{DD}	V
	V _{IL1}	-	-0.3	-	0.6	
Input Voltage (2) (OSC1)	V _{IH2}	-	V _{DD} -1.0	-	V _{DD}	V
	V _{IL2}	-	-0.2	-	1.0	
Output Voltage (1) (DB0 to DB7)	V _{OH1}	I _{OH} = -0.205 mA	2.4	-	-	V
	V _{OL1}	I _{OL} = 1.2 mA	-	-	0.4	
Output Voltage (2) (except DB0 to DB7)	V _{OH2}	I _O = -40 μA	0.9V _{DD}	-	-	V
	V _{OL2}	I _O = 40 μA	-	-	0.1V _{DD}	
Voltage Drop	V _{dCOM}	I _O = ± 0.1 mA	-	-	1	V
	V _{dSEG}		-	-	1	
Input Leakage Current	I _{IKG}	V _{IN} = 0 V to V _{DD}	-1	-	1	μA
Input Low Current	I _{IL}	V _{IN} = 0 V, V _{DD} = 5 V (PULL UP)	-50	-125	-250	
Internal Clock (external Rf)	f _{OSC1}	Rf = 91 kΩ ± 2% (V _{DD} = 5 V)	190	270	350	kHz
External Clock	f _{OSC}	-	125	270	410	kHz
	duty		45	50	55	%
	t _R , t _F		-	-	0.2	μs
LCD Driving Voltage	V _{LCD}	V _{DD} -V _S (1/5, 1/4 Bias)	3.0	-	13.0	V

2.AC Characteristics

(VDD = 4.8V ~ 5.5V, Ta = -30 ~ +85)

Mode	Characteristic	Symbol	Min.	Typ.	Max.	Unit
Write Mode (Refer to Fig-6)	E Cycle Time	tc	500	-	-	ns
	E Rise / Fall Time	t _R ,t _F	-	-	20	
	E Pulse Width (High, Low)	tw	230	-	-	
	R/W and RS Setup Time	tsu1	40	-	-	
	R/W and RS Hold Time	t _{H1}	10	-	-	
	Data Setup Time	tsu2	80	-	-	
	Data Hold Time	t _{H2}	10	-	-	
Read Mode (Refer to Fig-7)	E Cycle Time	tc	500	-	-	ns
	E Rise / Fall Time	t _R ,t _F	-	-	20	
	E Pulse Width (High, Low)	tw	230	-	-	
	R/W and RS Setup Time	tsu	40	-	-	
	R/W and RS Hold Time	t _H	10	-	-	
	Data Output Delay Time	t _D	-	-	120	
	Data Hold Time	t _{DH}	5	-	-	

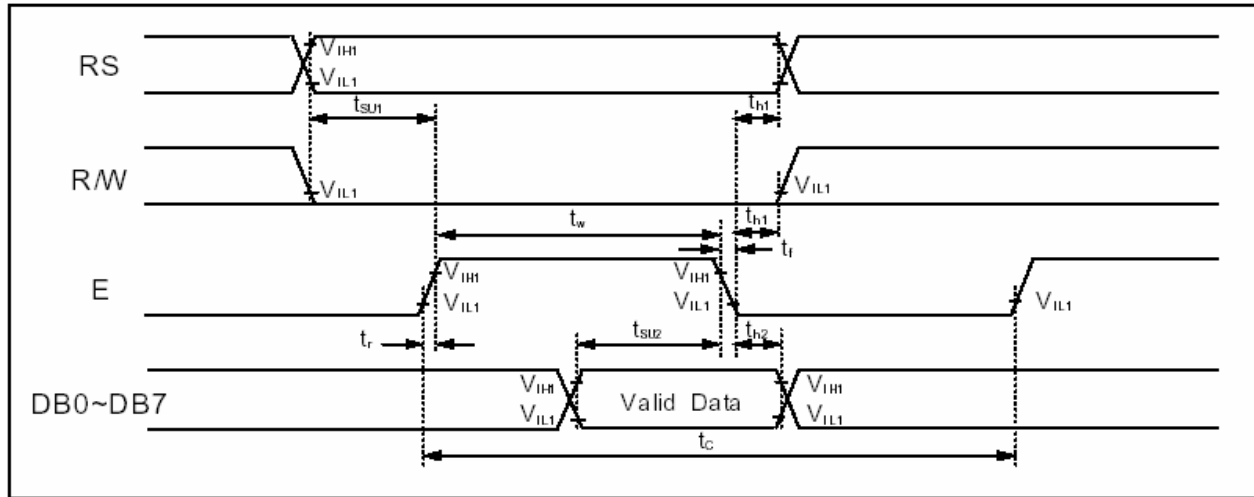

Figure 6 . Write Mode Timing Diagram

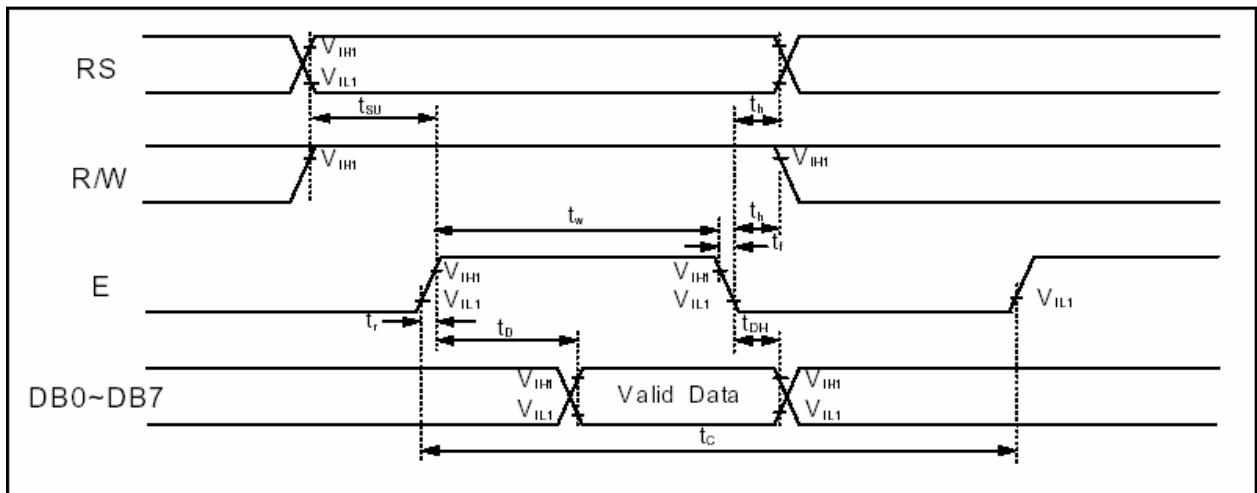

Figure 7 . Read Mode Timing Diagram

8. CONTROL AND DISPLAY INSTRUCTION

Instruction	Instruction Code										Description	Execution time (fosc=270KHz)	
	RS	RW	DB7	DB6	DB5	DB4	DB3	DB2	DB1	DB0			
Clear Display	0	0	0	0	0	0	0	0	0	1	Write "20H" to DDRAM and set DDRAM address to "00H" from AC	1.52ms	
Return Home	0	0	0	0	0	0	0	0	0	1	-	Set DDRAM address to "00H" from AC and return cursor to its original position if shifted. The contents of DDRAM are not changed.	1.52ms
Entry Mode Set	0	0	0	0	0	0	0	0	1	I/D	S	Assign cursor moving direction and enable the shift of entire display	38μs
Display ON/OFF Control	0	0	0	0	0	0	0	1	D	C	B	Set display(D), cursor(C), and blinking of cursor(B) on/off control bit.	38μs
Cursor or Display Shift	0	0	0	0	0	0	1	S/C	R/L	-	-	Set cursor moving and display shift control bit, and the direction, without changing of DDRAM data.	38μs
Function Set	0	0	0	0	0	1	DL	N	F	-	-	Set interface data length (DL: 8-bit/4-bit), numbers of display line (N: 2-line/1-line) and, display font type (F:5x10 dots/5x8 dots)	38μs
Set CGRAM Address	0	0	0	1	AC5	AC4	AC3	AC2	AC1	AC0		Set CGRAM address in address counter.	38μs
Set DDRAM Address	0	0	1	AC6	AC5	AC4	AC3	AC2	AC1	AC0		Set DDRAM address in counter	38μs
Read Busy Flag and Address Counter	0	1	BF	AC6	AC5	AC4	AC3	AC2	AC1	AC0		Whether during internal operation or not can be known by reading BF. The contents of address counter can also be read.	
Write Data to RAM	1	0	D7	D6	D5	D4	D3	D2	D1	D0		Write data into internal RAM (DDRAM/CGRAM).	38μs
Read Data from RAM	1	1	D7	D6	D5	D4	D3	D2	D1	D0		Read data from internal RAM (DDRAM/CGRAM).	38μs

NOTE: When an MPU program with checking the Busy Flag(DB7) is made, it must be necessary 1/2Fosc is necessary for executing the next instruction by the falling edge of the 'E' signal after the Busy Flag (DB7) goes to "Low".

9.? BACK LIGHT CHARACTERISTICS

LCD Module with bottom LED Backlight
ELECTRICAL RATINGS

Ta = 25°C

Item	Symbol	Condition	Min	Typ	Max	Unit
Forward Voltage	VF	IF=160mA	4.0	4.2	4.4	V
Reverse Current	IR	VR=5V	---	30	--	uA
Luminous Intensity (With LCD dots off)	IV	IF=160mA	---	--	---	Cd/m ²
Wave length	??	IF=160mA	---	572	---	nm
Color	Yellow-Green					

10. ELECTRO-OPTICAL CHARACTERISTICS?

(V_{OP} = 5.0V, Ta = 25°C)

Item	Symbol	Condition	Min	Typ	Max	Unit
Operating Voltage	Vop	Ta = -20°C	5.3	5.5	5.7	V
		Ta = 25°C	4.8	5.0	5.2	
		Ta = 70°C	4.3	4.5	4.7	
Response time	Tr	Ta = 25°C	---	185	---	ms
	Tf		---	200	---	ms
Contrast	Cr	Ta = 25°C	---	4	---	---
Viewing angle range	θ	Cr 2	-40	---	+40	deg
			-40	---	+40	deg

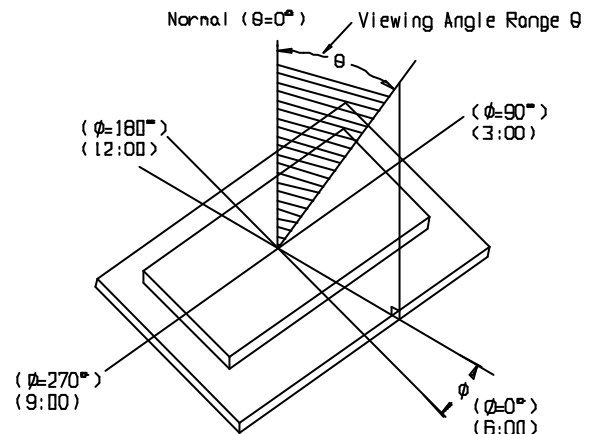
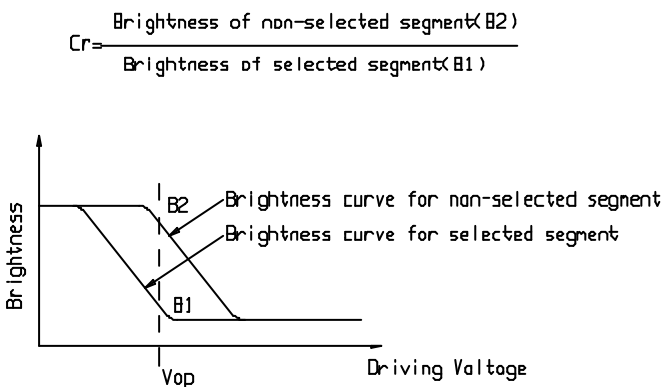

11.FONT CHARACTERISTICS

Upper 4 bit Lower 4 bit	LLLL	LLLH	LLHL	LLHH	LHLL	LHLH	LHHL	LHHH	HLLL	HLLH	HLHL	HLHH	HHLL	HHLH	HHHL	HHHH
LLLL				0	1	2	3	4	5	6	7	8	9	A	B	C
LLLH			!	1	A	Q	a	n			.	ア	キ	シ	フ	ク
LLHL			"	2	B	R	b	r			「	イ	ウ	×	フ	ク
LLHH			#	3	C	S	c	s			」	ウ	テ	モ	シ	ク
LHLL			\$	4	D	T	d	t			、	エ	ト	ナ	ム	ク
LHLH			%	5	E	U	e	u			・	オ	カ	キ	ク	ク
LHHL			&	6	F	V	f	v			ヲ	カ	ニ	ヨ	ク	ク
LHHH			'	7	G	W	g	w			ヲ	キ	マ	ウ	ク	ク
HLLL			(8	H	X	h	x			イ	ウ	キ	リ	ク	ク
HLLH)	9	I	Y	i	y			カ	ウ	ル	ク	ク	ク
HLHL			*	:	J	Z	j	z			キ	コ	ク	ク	ク	ク
HLHH			+	;	K	L	k	l			キ	カ	ク	ク	ク	ク
HHLL			,	<	L	羊	l	l			カ	シ	ク	ク	ク	ク
HHLH			-	=	M	J	m	j			ユ	マ	ク	ク	ク	ク
HHHL			.	>	N	^	n	^			ヨ	マ	ク	ク	ク	ク
HHHH			/	?	O	_	o	_			ウ	ウ	マ	ク	ク	ク

12.QUALITY SPECIFICATIONS

12.1 Standard of the product appearance test

Manner of appearance test: The inspection should be performed in using 20W x 2 fluorescent lamps. Distance between LCM and fluorescent lamps should be 100 cm or more. Distance between LCM and inspector eyes should be 30 cm or more.

Viewing direction for inspection is 45° from vertical against LCM.

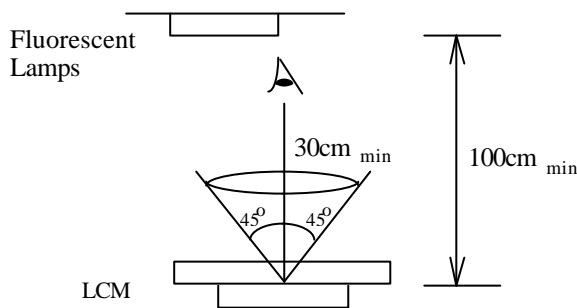

Definition of zone:

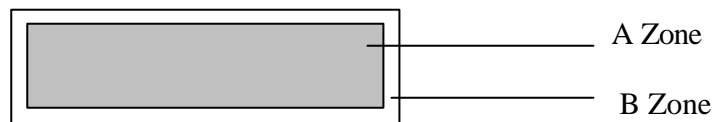

A Zone: Active display area (minimum viewing area).

B Zone: Non-active display area (outside viewing area).

12.2 Specification of quality assurance

AQL inspection standard

Sampling method: MIL-STD-105E, Level II, single sampling

Defect classification (Note: * is not including)

Classify	Item	Note	AQL	
Major	Display state	Short or open circuit	1	0.65
		LC leakage		
		Flickering		
		No display		
		Wrong viewing direction		
	Contrast defect (dim, ghost)	2		
	Back-light	1,8		
Non-display	Flat cable or pin reverse	10		
	Wrong or missing component	11		
Minor	Display state	Background color deviation	2	1.0
		Black spot and dust	3	
		Line defect, Scratch	4	
		Rainbow	5	
		Chip	6	
		Pin hole	7	
		Protruded	12	
	Polarizer	Bubble and foreign material	3	
	Soldering	Poor connection	9	
	Wire	Poor connection	10	
	TAB	Position, Bonding strength	13	

Note on defect classification

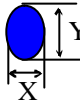
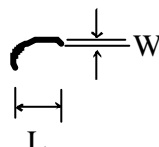
No.	Item	Criterion																				
1	Short or open circuit	Not allow																				
	LC leakage																					
	Flickering																					
	No display																					
	Wrong viewing direction																					
	Wrong Back-light																					
2	Contrast defect	Refer to approval sample																				
	Background color deviation																					
3	Point defect, Black spot, dust (including Polarizer) $\phi = (X+Y)/2$	 <table border="1" data-bbox="912 996 1332 1288"> <thead> <tr> <th>Point Size</th> <th>Acceptable Qty.</th> </tr> </thead> <tbody> <tr> <td>$\phi \leq 0.10$</td> <td>Disregard</td> </tr> <tr> <td>$0.10 < \phi \leq 0.20$</td> <td>3</td> </tr> <tr> <td>$0.20 < \phi \leq 0.25$</td> <td>2</td> </tr> <tr> <td>$0.25 < \phi \leq 0.30$</td> <td>1</td> </tr> <tr> <td>$\phi > 0.30$</td> <td>0</td> </tr> </tbody> </table> <p>Unit : mm</p>	Point Size	Acceptable Qty.	$\phi \leq 0.10$	Disregard	$0.10 < \phi \leq 0.20$	3	$0.20 < \phi \leq 0.25$	2	$0.25 < \phi \leq 0.30$	1	$\phi > 0.30$	0								
Point Size	Acceptable Qty.																					
$\phi \leq 0.10$	Disregard																					
$0.10 < \phi \leq 0.20$	3																					
$0.20 < \phi \leq 0.25$	2																					
$0.25 < \phi \leq 0.30$	1																					
$\phi > 0.30$	0																					
4	Line defect, Scratch	 <table border="1" data-bbox="842 1451 1372 1706"> <thead> <tr> <th colspan="2">Line</th> <th>Acceptable Qty.</th> </tr> <tr> <th>L</th> <th>W</th> <th></th> </tr> </thead> <tbody> <tr> <td>---</td> <td>$0.015 < W$</td> <td>Disregard</td> </tr> <tr> <td>3.0 L</td> <td>$0.03 < W$</td> <td rowspan="2">2</td> </tr> <tr> <td>2.0 L</td> <td>$0.05 < W$</td> </tr> <tr> <td>1.0 L</td> <td>$0.1 > W$</td> <td>1</td> </tr> <tr> <td>---</td> <td>$0.05 < W$</td> <td>Applied as point defect</td> </tr> </tbody> </table> <p>Unit: mm</p>	Line		Acceptable Qty.	L	W		---	$0.015 < W$	Disregard	3.0 L	$0.03 < W$	2	2.0 L	$0.05 < W$	1.0 L	$0.1 > W$	1	---	$0.05 < W$	Applied as point defect
	Line		Acceptable Qty.																			
L	W																					
---	$0.015 < W$	Disregard																				
3.0 L	$0.03 < W$	2																				
2.0 L	$0.05 < W$																					
1.0 L	$0.1 > W$	1																				
---	$0.05 < W$	Applied as point defect																				
5	Rainbow	Not more than two color changes across the viewing area.																				

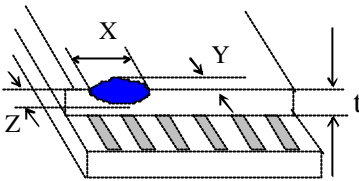
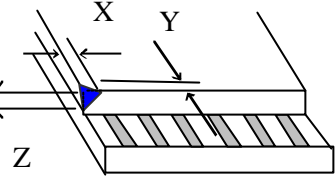
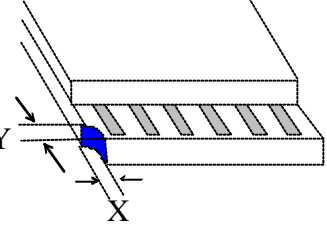
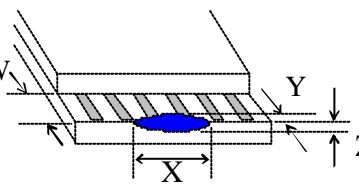
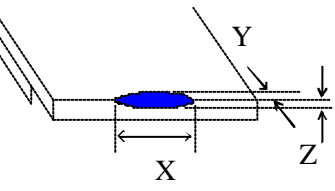
No	Item	Criterion																																
6	<p>Chip</p> <p>Remark:</p> <p>X: Length direction</p> <p>Y: Short direction</p> <p>Z: Thickness direction</p> <p>t: Glass thickness</p> <p>W: Terminal Width</p>	 <p>Acceptable criterion</p> <table border="1" data-bbox="981 504 1356 582"> <thead> <tr> <th>X</th> <th>Y</th> <th>Z</th> </tr> </thead> <tbody> <tr> <td>2</td> <td>0.5mm</td> <td>t/2</td> </tr> </tbody> </table>  <p>Acceptable criterion</p> <table border="1" data-bbox="965 795 1356 884"> <thead> <tr> <th>X</th> <th>Y</th> <th>Z</th> </tr> </thead> <tbody> <tr> <td>2</td> <td>0.5mm</td> <td>t</td> </tr> </tbody> </table>  <p>Acceptable criterion</p> <table border="1" data-bbox="981 1086 1356 1198"> <thead> <tr> <th>X</th> <th>Y</th> <th>Z</th> </tr> </thead> <tbody> <tr> <td>3</td> <td>2</td> <td rowspan="2">t</td> </tr> <tr> <td colspan="2">shall not reach to ITO</td> </tr> </tbody> </table>  <p>Acceptable criterion</p> <table border="1" data-bbox="965 1444 1356 1534"> <thead> <tr> <th>X</th> <th>Y</th> <th>Z</th> </tr> </thead> <tbody> <tr> <td>Disregard</td> <td>0.2</td> <td>t</td> </tr> </tbody> </table>  <p>Acceptable criterion</p> <table border="1" data-bbox="965 1724 1324 1803"> <thead> <tr> <th>X</th> <th>Y</th> <th>Z</th> </tr> </thead> <tbody> <tr> <td>5</td> <td>2</td> <td>t/3</td> </tr> </tbody> </table>	X	Y	Z	2	0.5mm	t/2	X	Y	Z	2	0.5mm	t	X	Y	Z	3	2	t	shall not reach to ITO		X	Y	Z	Disregard	0.2	t	X	Y	Z	5	2	t/3
X	Y	Z																																
2	0.5mm	t/2																																
X	Y	Z																																
2	0.5mm	t																																
X	Y	Z																																
3	2	t																																
shall not reach to ITO																																		
X	Y	Z																																
Disregard	0.2	t																																
X	Y	Z																																
5	2	t/3																																

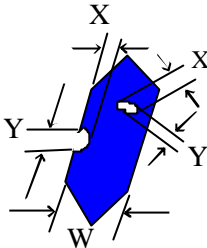
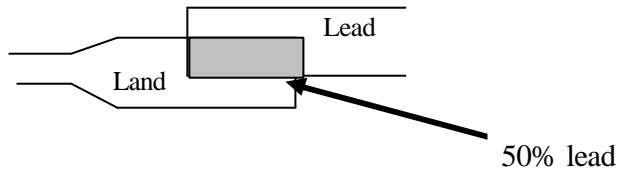
No.	Item	Criterion								
7	Segment pattern W = Segment width $\phi = (X+Y)/2$	<p>(1) Pin hole $\phi < 0.10\text{mm}$ is acceptable.</p>  <table border="1" data-bbox="901 660 1348 840"> <thead> <tr> <th>Point Size</th> <th>Acceptable Qty</th> </tr> </thead> <tbody> <tr> <td>$\phi < 1/4W$</td> <td>Disregard</td> </tr> <tr> <td>$1/4W < \phi < 1/2W$</td> <td>1</td> </tr> <tr> <td>$\phi > 1/2W$</td> <td>0</td> </tr> </tbody> </table> <p style="text-align: center;">Unit: mm</p>	Point Size	Acceptable Qty	$\phi < 1/4W$	Disregard	$1/4W < \phi < 1/2W$	1	$\phi > 1/2W$	0
Point Size	Acceptable Qty									
$\phi < 1/4W$	Disregard									
$1/4W < \phi < 1/2W$	1									
$\phi > 1/2W$	0									
8	Back-light	<p>(1) The color of backlight should correspond its specification. (2) Not allow flickering</p>								
9	Soldering	<p>(1) Not allow heavy dirty and solder ball on PCB. (The size of dirty refer to point and dust defect) (2) Over 50% of lead should be soldered on Land.</p> 								
10	Wire	<p>(1) Copper wire should not be rusted (2) Not allow crack on copper wire connection. (3) Not allow reversing the position of the flat cable. (4) Not allow exposed copper wire inside the flat cable.</p>								
11*	PCB	<p>(1) Not allow screw rust or damage. (2) Not allow missing or wrong putting of component.</p>								

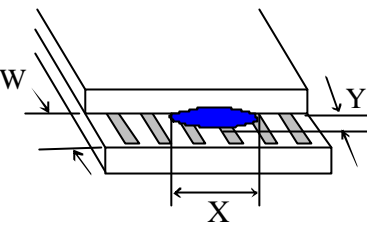
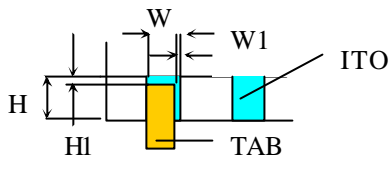
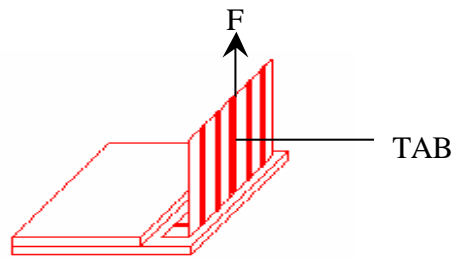
No	Item	Criterion				
12	Protruded W: Terminal Width	 <p>Acceptable criteria: $Y \leq 0.4$</p>				
13	TAB	<p>1. Position</p>  <table border="1" data-bbox="1161 817 1385 945"> <tr> <td>W1</td> <td>1/3W</td> </tr> <tr> <td>H1</td> <td>1/3H</td> </tr> </table> <p>2. TAB bonding strength test</p>  <p> $P (=F/TAB \text{ bonding width})$ 650gf/cm ,(speed rate: 1mm/min) 5pcs per SOA (shipment) </p>	W1	1/3W	H1	1/3H
W1	1/3W					
H1	1/3H					
14	Total no. of acceptable Defect	<p>A. Zone</p> <p>Maximum 2 minor non-conformities per one unit. Defect distance: each point to be separated over 10mm</p> <p>B. Zone</p> <p>It is acceptable when it is no trouble for quality and assembly in customer's end product.</p>				

12.3 Reliability of LCM

Reliability test condition:

Item	Condition	Time (hrs)	Assessment
High temp. Storage	80°C	48	No abnormalities in functions and appearance
High temp. Operating	70°C	48	
Low temp. Storage	-30°C	48	
Low temp. Operating	-20°C	48	
Humidity	40°C/ 90%RH	48	
Temp. Cycle	0°C ← 25°C → 50°C (30 min ← 5 min → 30min)	10cycles	

Recovery time should be 24 hours minimum. Moreover, functions, performance and appearance shall be free from remarkable deterioration within 50,000 hours under ordinary operating and storage conditions room temperature (20±8°C), normal humidity (below 65% RH), and in the area not exposed to direct sun light.

12.4 Precaution for using LCD/ICM

LCD/LCM is assembled and adjusted with a high degree of precision. Do not attempt to make any alteration or modification. The followings should be noted.

General Precautions:

1. LCD panel is made of glass. Avoid excessive mechanical shock or applying strong pressure onto the surface of display area.
2. The polarizer used on the display surface is easily scratched and damaged. Extreme care should be taken when handling. To clean dust or dirt off the display surface, wipe gently with cotton, or other soft material soaked with isopropyl alcohol, ethyl alcohol or trichlorotrifluoroethane, do not use water, ketone or aromatics and never scrub hard.
3. Do not tamper in any way with the tabs on the metal frame.
4. Do not made any modification on the PCB without consulting Gemini.
5. When mounting a LCM, make sure that the PCB is not under any stress such as bending or twisting. Elastomer contacts are very delicate and missing pixels could result from slight dislocation of any of the elements.
6. Avoid pressing on the metal bezel, otherwise the elastomer connector could be deformed and lose contact, resulting in missing pixels and also cause rainbow on the display.

7. Be careful not to touch or swallow liquid crystal that might leak from a damaged cell. Any liquid crystal adheres to skin or clothes, wash it off immediately with soap and water.

Static Electricity Precautions:

1. CMOS-LSI is used for the module circuit; therefore operators should be grounded whenever he/she comes into contact with the module.
2. Do not touch any of the conductive parts such as the LSI pads; the copper leads on the PCB and the interface terminals with any parts of the human body.
3. Do not touch the connection terminals of the display with bare hand; it will cause disconnection or defective insulation of terminals.
4. The modules should be kept in anti-static bags or other containers resistant to static for storage.
5. Only properly grounded soldering irons should be used.
6. If an electric screwdriver is used, it should be grounded and shielded to prevent sparks.
7. The normal static prevention measures should be observed for work clothes and working benches.
8. Since dry air is inductive to static, a relative humidity of 50-60% is recommended.

Soldering Precautions:

1. Soldering should be performed only on the I/O terminals.
2. Use soldering irons with proper grounding and no leakage.
3. Soldering temperature: $280^{\circ}\text{C} \pm 10^{\circ}\text{C}$
4. Soldering time: 3 to 4 second.
5. Use eutectic solder with resin flux filling.
6. If flux is used, the LCD surface should be protected to avoid spattering flux.
7. Flux residue should be removed.

Operation Precautions:

1. The viewing angle can be adjusted by varying the LCD driving voltage V_o .
2. Since applied DC voltage causes electro-chemical reactions, which deteriorate the display, the applied pulse waveform should be a symmetric waveform such that no DC component remains. Be sure to use the specified operating voltage.
3. Driving voltage should be kept within specified range; excess voltage will shorten display life.
4. Response time increases with decrease in temperature.
5. Display color may be affected at temperatures above its operational range.
6. Keep the temperature within the specified range usage and storage. Excessive temperature and humidity could cause polarization degradation, polarizer peel-off or generate bubbles.
7. For long-term storage over 40°C is required, the relative humidity should be kept below 60%, and avoid direct sunlight.



Limited Warranty

Gemini LCDs and modules are not consumer products, but may be incorporated by Gemini's customers into consumer products or components thereof, Gemini does not warrant that its LCDs and components are fit for any such particular purpose.

1. The liability of Gemini is limited to repair or replacement on the terms set forth below. Gemini will not be responsible for any subsequent or consequential events or injury or damage to any personnel or user including third party personnel and/or user. Unless otherwise agreed in writing between Gemini and the customer, Gemini will only replace or repair any of its LCD which is found defective electrically or visually when inspected in accordance with Gemini general LCD inspection standard .
(Copies available on request)
2. No warranty can be granted if any of the precautions state in handling liquid crystal display above has been disregarded. Broken glass, scratches on polarizer mechanical damages as well as defects that are caused accelerated environment tests are excluded from warranty.
3. In returning the LCD/LCM, they must be properly packaged; there should be detailed description of the failures or defect.