



GEMINI Technology Co., Ltd.
www.FindLCD.com

SPECIFICATION FOR LCM MODULE

MODULE NO: ABC020004B02-YIY-R-01
DOC. REVISION 00

Customer Approval:

www.FindLCD.com
--

	SIGNATURE	DATE
PREPARED BY (RD ENGINEER)		May-24-2010
PREPARED BY (QA ENGINEER)		
CHECKED BY		
APPROVED BY		



DOCUMENT REVISION HISTORY

Version	DATE	DESCRIPTION	CHANGED BY
00	May-24-2010	First issue	

CONTENTS

1. Functions & Features	1
2. Mechanical specifications	1
3. Block diagram	1
4. Dimensional Outline	2
5. Pin description	3
6. Maximum absolute limit	3
7. Electrical characteristics	4-5
8. Backlight specification	6
9. Electro-Optical characteristics	7
10. Control and display instruction	8
11. Font Characteristic	9
12. Precaution for using LCD/LCM	10-11
13. LCM test criteria	12-21

1. FUNCTIONS & FEATURES

- 1.1. Format : 20x4characters
- 1.2. LCD mode : STN/Positive/Transmissive/Y-G
- 1.3. Viewing direction : 6 o'clock
- 1.4. Driving scheme : 1/16 Duty , 1/5Bias
- 1.5. Power supply voltage (V_{DD}) : 5.0V
- 1.6. LCD driving voltage : 4.5V(reference voltage)
- 1.7. Operation temp : -20~70°C
- 1.8. Storage temp : -30~80°C
- 1.9. Backlight color : Bottom Yellow-Green
- 1.10 RoHS standard

2. MECHANICAL SPECIFICATIONS

- 2.1. Module size : 98.0mm(L)*60.0mm(W)*14.0mm (H) max
- 2.2. Viewing area : 77.0mm(L)*26.5mm(W)
- 2.3. Character pitch : 3.55mm(L)*5.35mm(W)
- 2.4. Character size : 2.95mm(L)*4.75mm(W)
- 2.5. Dot pitch : 0.6mm(L)*0.6mm(W)
- 2.6. Dot size : 0.55mm(L)*0.55mm(W)
- 2.7. Weight : Approx.

3. BLOCK DIAGRAM

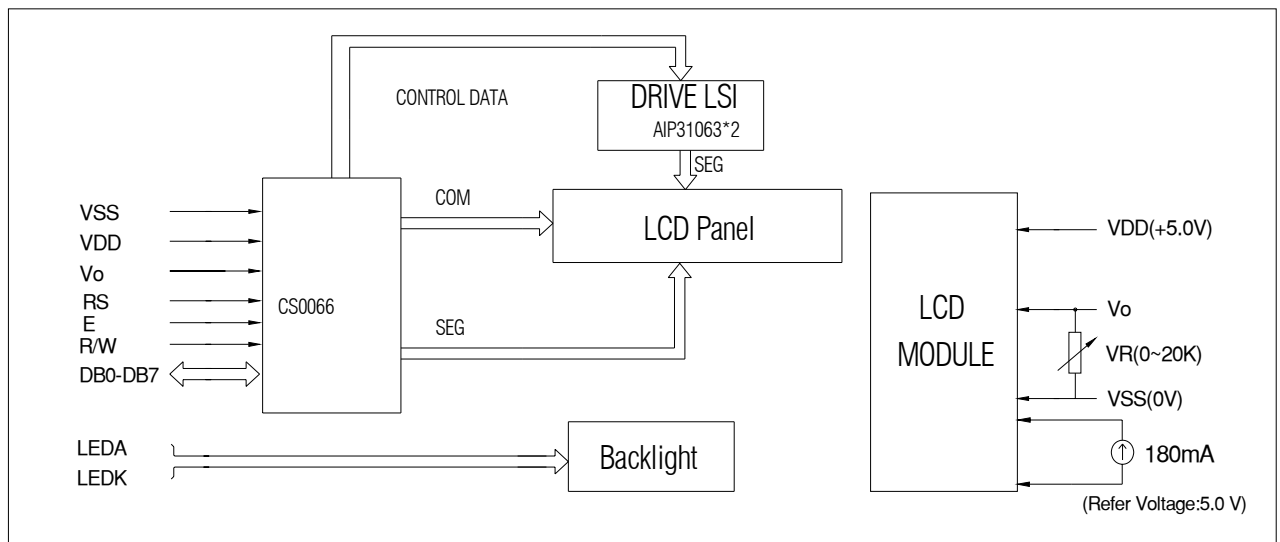

Figure 1. Block diagram

4. DIMENSIONAL OUTLINE

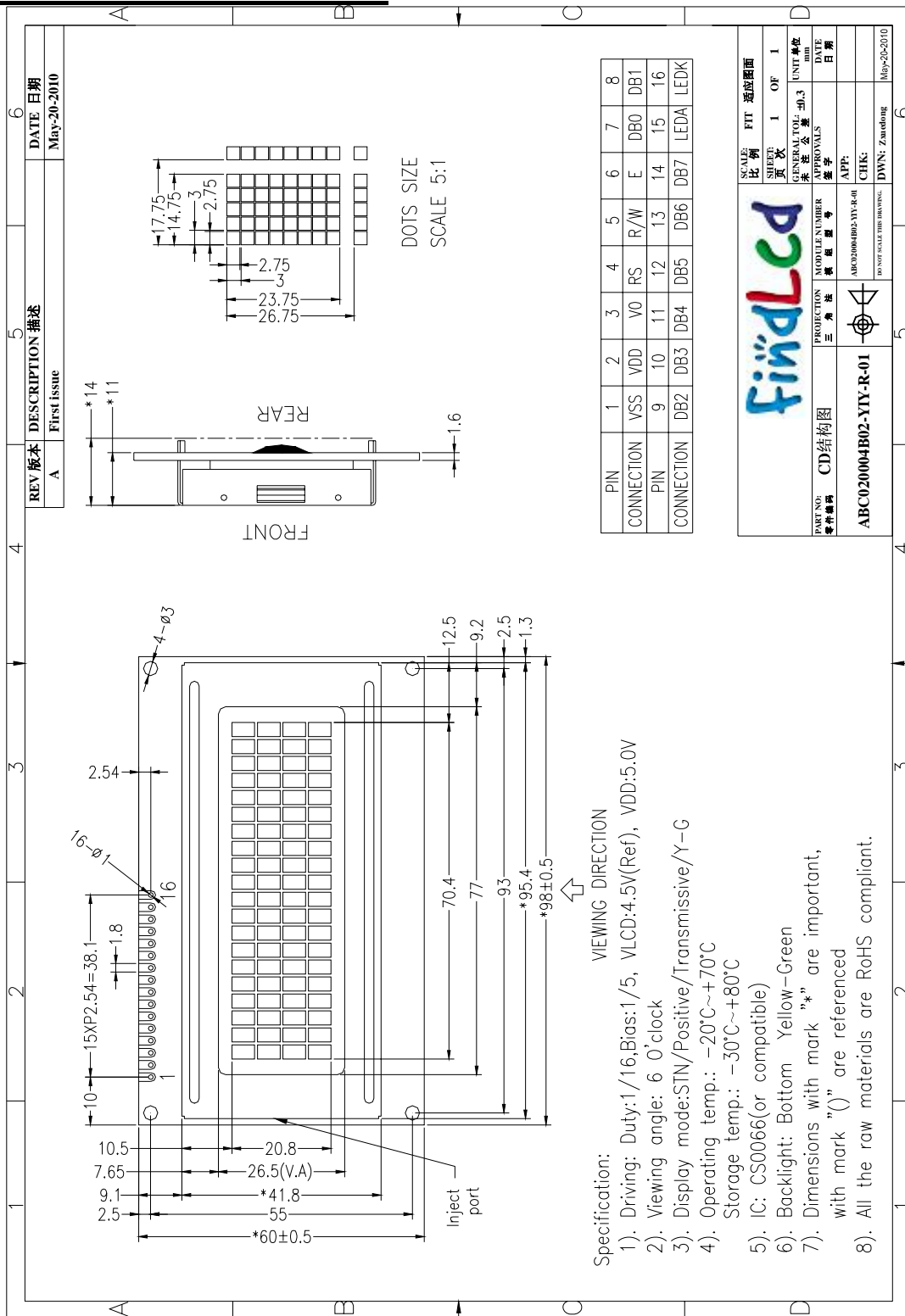

Figure 2. Dimensional outline

5. PIN DESCRIPTION

No.	Symbol	Function
1	VSS	Power ground (0V)
2	VDD	Power supply for Logic(+5V)
3	V0	Power supply for LCD drive
4	RS	Register selection (H: Data register , L :Instruction register)
5	R/W	Read/write selection (H: Read , L: Write)
6	E	Enable signal.
7~14	DB0~DB7	Data Bus line
15	LEDA	Power supply for Backlight(Current 180mA,reference voltage +5.0V)
16	LEDK	Power ground (0V)

6. MAXIMUM ABSOLUTE LIMIT

Item	Symbol	MIN	MAX	Unit
Supply Voltage for Logic	V _{DD}	-0.3	7.0	V
Supply Voltage for LCD	V ₀	V _{DD} -10.0	V _{DD} +0.3	V
Input Voltage	V _{in}	-0.3	V _{DD} +0.3	V
Supply Current for Backlight	I _F (T _a = 25°C)	---	60+60*20%	mA
Reverse Voltage for Backlight	V _R (T _a = 25°C)	---	0.8	V
Operating Temperature	T _{op}	-20	70	°C
Storage Temperature	T _{st}	-30	80	°C

7. ELECTRICAL CHARACTERISTICS

7.1 DC characteristics (VDD=4.5V-5.5V, TA=25°C)

Characteristic	Symbol	Condition	Min.	Typ.	Max.	Unit
Operating Voltage	V _{DD}	-	4.5	-	5.5	V
Supply Current	I _{DD}	Internal oscillation or external clock. (V _{DD} =5.0 V, f _{osc} = 270 kHz)	-	0.35	0.6	mA
Input Voltage (1) (except OSC1)	V _{IH1}	-	2.2	-	V _{DD}	V
	V _{IL1}	-	-0.3	-	0.6	
Input Voltage (2) (OSC1)	V _{IH2}	-	V _{DD} -1.0	-	V _{DD}	V
	V _{IL2}	-	-0.2	-	1.0	
Output Voltage (1) (DB0 to DB7)	V _{OH1}	I _{OH} = -0.205 mA	2.4	-	-	V
	V _{OL1}	I _{OL} = 1.2 mA	-	-	0.4	
Output Voltage (2) (except DB0 to DB7)	V _{OH2}	I _O = -40 mA	0.9V _{DD}	-	-	V
	V _{OL2}	I _O = 40 mA	-	-	0.1V _{DD}	
Voltage Drop	V _{dCOM}	I _O =± 0.1 mA	-	-	1	V
	V _{dSEG}		-	-	1	
Input Leakage Current	I _{IKG}	V _{IN} = 0 V to V _{DD}	-1	-	1	mA
Input Low Current	I _{IL}	V _{IN} = 0 V, V _{DD} = 5 V (PULL UP)	-50	-125	-250	
Internal Clock (external Rf)	f _{OSC1}	Rf = 91 kΩ ± 2% (V _{DD} = 5 V)	190	270	350	kHz
External Clock	f _{OSC}	-	125	270	410	kHz
	duty		45	50	55	%
	t _R , t _F		-	-	0.2	ms
LCD Driving Voltage	V _{LCD}	V _{DD} -V _S (1/5, 1/4 Bias)	3.0	-	13.0	V

7.2 AC characteristics(VDD=4.5V-5.5V, TA=25°C)

Write mode (writing data from MPU to CS0066)

Mode	Characteristic	Symbol	Min.	Typ.	Max.	Unit
Write Mode	E Cycle Time	t _c	500	-	-	ns
	E Rise / Fall Time	t _R , t _F	-	-	20	
	E Pulse Width (High, Low)	t _w	230	-	-	
	R/W and RS Setup Time	t _{SU1}	40	-	-	
	R/W and RS Hold Time	t _{H1}	10	-	-	
	Data Setup Time	t _{SU2}	80	-	-	
	Data Hold Time	t _{H2}	10	-	-	

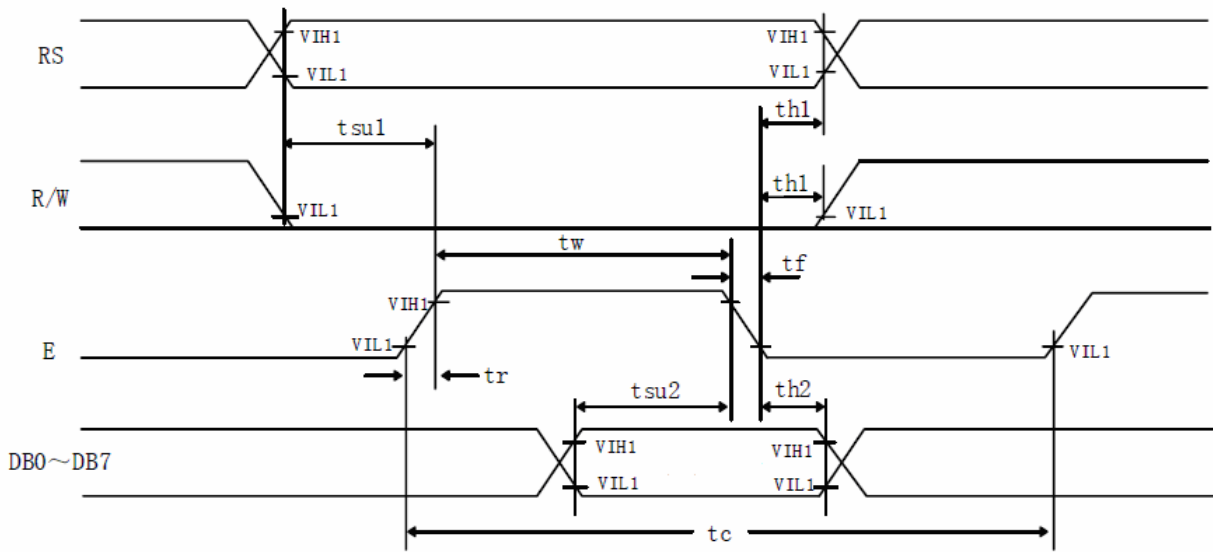

Read mode (reading data from CS0066 to MPU)

Mode	Characteristic	Symbol	Min.	Typ.	Max.	Unit
Read Mode	E Cycle Time	t_c	500	-	-	ns
	E Rise / Fall Time	t_r, t_f	-	-	20	
	E Pulse Width (High, Low)	t_w	230	-	-	
	R/W and RS Setup Time	t_{su}	40	-	-	
	R/W and RS Hold Time	t_h	10	-	-	
	Data Output Delay Time	t_D	-	-	120	
	Data Hold Time	t_{DH}	5	-	-	

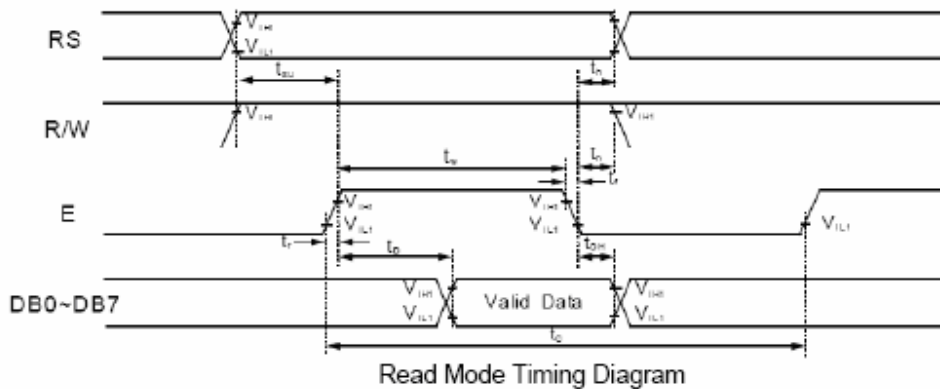

Interface mode with LCD driver

Mode	Characteristic	Symbol	Min.	Typ.	Max.	Unit
Interface Mode with Extension Driver (Refer to Fig-3)	Clock Pulse Width (High, Low)	t_c	800	-	-	ns
	Clock Rise / Fall Time	t_R, t_F	-	-	25	
	Clock Setup Time	t_{su1}	500	-	-	
	Data Setup Time	t_{su2}	300	-	-	
	Data Hold Time	t_{DH}	300	-	-	
	M Delay Time	t_{DM}	-1000	-	1000	

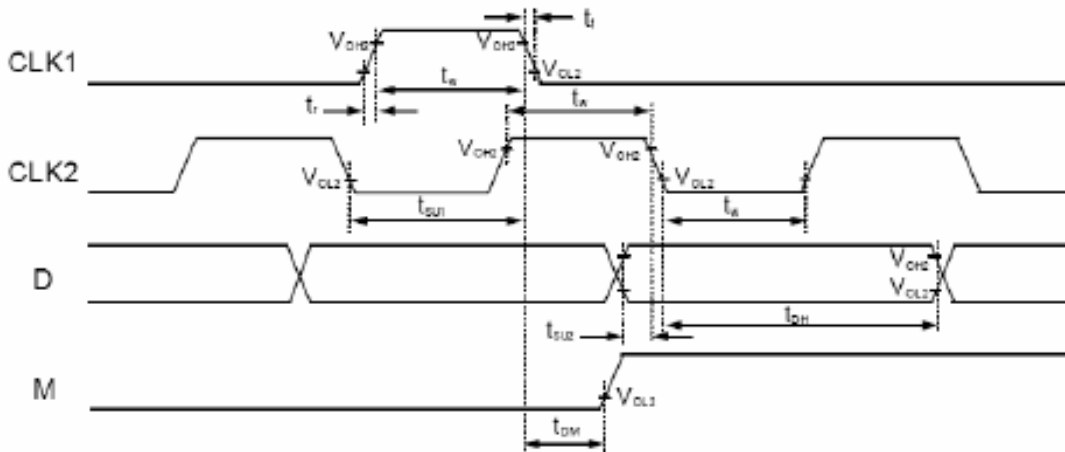

Figure 3 . Interface Mode With Extension Driver Timing Diagram

8. BACKLIGHT CHARACTERISTICS

LCD Module with Bottom Yellow-Green LED Backlight

ELECTRICAL RATINGS

Ta = 25°C

Item	Symbol	Condition	Min	Typ	Max	Unit
Forward Voltage	VF	IF=180mA	3.8	4.05	4.2	V
Reverse Current	IR	VR=0.8V	---	---	100	uA
Luminous Intensity (Without LCD)	Lv	IF=180mA	80	100	---	cd/m ²
Peak wave length	λ	IF=180mA	---	568	---	nm
Color	Yellow-Green					

Note:

when the temperature exceed 25°C, the approved current decrease rate for Backlight change as the temperature increase is: -0.36x4mA/°C (below 25°C, the current refer to constant, which would not change with temperature).

9. ELECTRO-OPTICAL CHARACTERISTICS

($V_{DD}=5.0V, T_a = 25^{\circ}C$)

Item	Symbol	Condition	Min	Typ	Max	Unit
Operating Voltage	Vop	Ta = -20°C	4.8	5.0	5.2	V
		Ta = 25°C	4.3	4.5	4.8	
		Ta = 70°C	4.0	4.2	4.4	
Response time	Tr	Ta = 25°C	---	185	---	ms
	Tf		---	200	---	ms
Contrast	Cr	Ta = 25°C	---	5	---	---
Viewing angle range	θ	Cr \geq 2	-40	---	+40	deg
	Φ		-40	---	+40	deg

$$Cr = \frac{\text{Brightness of non-selected segment}(B2)}{\text{Brightness of selected segment}(B1)}$$

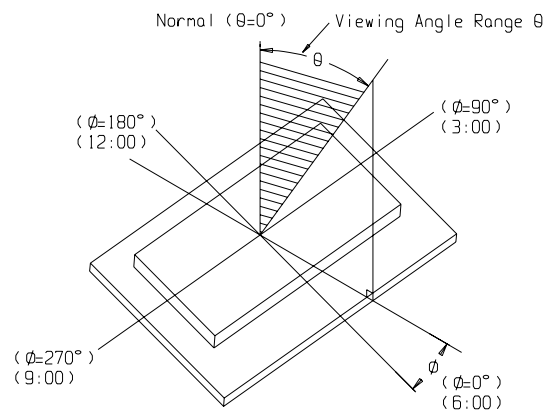
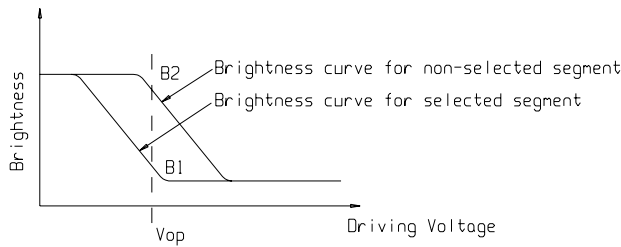

10. CONTROL AND DISPLAY INSTRUCTION

Instruction	Instruction Code										Description	Execution time (fosc=270KHz)	
	RS	RW	DB7	DB6	DB5	DB4	DB3	DB2	DB1	DB0			
Clear Display	0	0	0	0	0	0	0	0	0	1	Write "20H" to DDRAM and set DDRAM address to "00H" from AC	1.52ms	
Return Home	0	0	0	0	0	0	0	0	0	1	-	Set DDRAM address to "00H" from AC and return cursor to its original position if shifted. The contents of DDRAM are not changed.	1.52ms
Entry Mode Set	0	0	0	0	0	0	0	0	1	I/D	S	Assign cursor moving direction and enable the shift of entire display	38μs
Display ON/OFF Control	0	0	0	0	0	0	0	1	D	C	B	Set display(D), cursor(C), and blinking of cursor(B) on/off control bit.	38μs
Cursor or Display Shift	0	0	0	0	0	1	S/C	R/L	-	-	-	Set cursor moving and display shift control bit, and the direction, without changing of DDRAM data.	38μs
Function Set	0	0	0	0	1	DL	N	F	-	-	-	Set interface data length (DL: 8-bit/4-bit), numbers of display line (N: 2-line/1-line) and, display font type (F:5x10 dots/5x8 dots)	38μs
Set CGRAM Address	0	0	0	1	AC5	AC4	AC3	AC2	AC1	AC0	-	Set CGRAM address in address counter.	38μs
Set DDRAM Address	0	0	1	AC6	AC5	AC4	AC3	AC2	AC1	AC0	-	Set DDRAM address in counter	38μs
Read Busy Flag and Address Counter	0	1	BF	AC6	AC5	AC4	AC3	AC2	AC1	AC0	-	Whether during internal operation or not can be known by reading BF. The contents of address counter can also be read.	
Write Data to RAM	1	0	D7	D6	D5	D4	D3	D2	D1	D0	-	Write data into internal RAM (DDRAM/CGRAM).	38μs
Read Data from RAM	1	1	D7	D6	D5	D4	D3	D2	D1	D0	-	Read data from internal RAM (DDRAM/CGRAM).	38μs

Note: "-": don't care

11. FONT CHARACTERISTIC

Upper 4 bit Lower 4 bit	LLLL	LLLH	LLHL	LLHH	LHLL	LHLH	LHHL	LHHH	HLLL	HLLH	HLHL	HLHH	HHLL	HHLH	HHHL	HHHH
LLLL				0	1	2	3	4				一	夕	三	四	五
LLLH			!	1	10	11	12	13				。	ア	チ	△	▽
LLHL			"	2	B	R	b	r				「	イ	ウ	×	◎
LLHH			#	3	O	S	s	S				」	ウ	テ	モ	◎
LHLL			*	4	D	T	t	T				、	エ	ト	ナ	△
LHLH			%	5	E	U	u	U				・	オ	カ	工	△
LHHL			&	6	F	V	v	V				ヲ	カ	ニ	ヨ	△
LHHH			'	7	G	W	w	W				ヲ	キ	又	ウ	△
HLLL			(8	H	X	x	X				イ	ウ	キ	リ	△
HLLH)	9	I	Y	y	Y				ウ	ウ	ル	リ	△
HLHL			*	*	J	Z	z	Z				エ	コ	△	△	△
HLHH			+	*	K	k	K	k				オ	オ	△	△	△
HHLL			,	<	L	羊	羊	羊				カ	△	△	△	△
HHLH			-	=	M	△	△	△				ユ	又	△	△	△
HHHL			.	>	N	△	△	△				ヨ	△	△	△	△
HHHH			/	?	O	△	△	△				ウ	ウ	△	△	△

12. PRECAUTION FOR USING LCD/LCM

After reliability test, recovery time should be 24 hours minimum. Moreover, functions, performance and appearance shall be free from remarkable deterioration within 50,000 hours (average) under ordinary operating and storage conditions room temperature ($20\pm 8^{\circ}\text{C}$), normal humidity (below 65% RH), and in the area not exposed to direct sun light. Using LCM beyond these conditions will shorten the life time.

Precaution for using LCD/LCM

LCD/LCM is assembled and adjusted with a high degree of precision. Do not attempt to make any alteration or modification. The followings should be noted.

General Precautions:

1. LCD panel is made of glass. Avoid excessive mechanical shock or applying strong pressure onto the surface of display area.
2. The polarizer used on the display surface is easily scratched and damaged. Extreme care should be taken when handling. To clean dust or dirt off the display surface, wipe gently with cotton, or other soft material soaked with isopropyl alcohol, ethyl alcohol or trichlorotrifluoroethane, do not use water, ketone or aromatics and never scrub hard.
3. Do not tamper in any way with the tabs on the metal frame.
4. Do not make any modification on the PCB without consulting Gemini.
5. When mounting a LCM, make sure that the PCB is not under any stress such as bending or twisting. Elastomer contacts are very delicate and missing pixels could result from slight dislocation of any of the elements.
6. Avoid pressing on the metal bezel, otherwise the elastomer connector could be deformed and lose contact, resulting in missing pixels and also cause rainbow on the display.
7. Be careful not to touch or swallow liquid crystal that might leak from a damaged cell. Any liquid crystal adheres to skin or clothes, wash it off immediately with soap and water.

Static Electricity Precautions:

1. CMOS-LSI is used for the module circuit; therefore operators should be grounded whenever he/she comes into contact with the module.
2. Do not touch any of the conductive parts such as the LSI pads; the copper leads on the PCB and the interface terminals with any parts of the human body.
3. Do not touch the connection terminals of the display with bare hand; it will cause disconnection or defective insulation of terminals.

4. The modules should be kept in anti-static bags or other containers resistant to static for storage.
5. Only properly grounded soldering irons should be used.
6. If an electric screwdriver is used, it should be grounded and shielded to prevent sparks.
7. The normal static prevention measures should be observed for work clothes and working benches.
8. Since dry air is inductive to static, a relative humidity of 50-60% is recommended.

Soldering Precautions:

1. Soldering should be performed only on the I/O terminals.
2. Use soldering irons with proper grounding and no leakage.
3. Soldering temperature: $280^{\circ}\text{C} \pm 10^{\circ}\text{C}$
4. Soldering time: 3 to 4 second.
5. Use eutectic solder with resin flux filling.
6. If flux is used, the LCD surface should be protected to avoid spattering flux.
7. Flux residue should be removed.

Operation Precautions:

1. The viewing angle can be adjusted by varying the LCD driving voltage V_o .
2. Since applied DC voltage causes electro-chemical reactions, which deteriorate the display, the applied pulse waveform should be a symmetric waveform such that no DC component remains. Be sure to use the specified operating voltage.
3. Driving voltage should be kept within specified range; excess voltage will shorten display life.
4. Response time increases with decrease in temperature.
5. Display color may be affected at temperatures above its operational range.
6. Keep the temperature within the specified range usage and storage. Excessive temperature and humidity could cause polarization degradation, polarizer peel-off or generate bubbles.
7. For long-term storage over 40°C is required, the relative humidity should be kept below 60%, and avoid direct sunlight.

Limited Warranty

Gemini LCDs and modules are not consumer products, but may be incorporated by Gemini's customers into consumer products or components thereof, Gemini does not warrant that its LCDs and components are fit for any such particular purpose.

1. The liability of Gemini is limited to repair or replacement on the terms set forth below. Gemini will not be responsible for any subsequent or consequential events or injury or damage to any personnel or user including third party personnel and/or user. Unless otherwise agreed in writing between Gemini and the customer, Gemini will only replace or repair any of its LCD which is found defective electrically or visually when inspected in accordance with Gemini general LCD inspection standard . (Copies available on request)
2. No warranty can be granted if any of the precautions state in handling liquid crystal display above has been disregarded. Broken glass, scratches on polarizer mechanical damages as well as defects that are caused accelerated environment tests are excluded from warranty.
3. In returning the LCD/LCM, they must be properly packaged; there should be detailed description of the failures or defect.

13. LCM test criteria

1. Objective

The criteria is applied for consolidating the LCM quality standard between Gemini and customer in finished products acceptance inspection and shipment, to guarantee the products quality to meet with customer's demand.

2. Scope

2.1 This criteria is applicable to all the LCM products produced by Gemini.

3. Inspection equipment

Function Tester、 Vernier Calipers、 Microscope、 Magnifier、 ESD Wrist Strap、 Finger Cover、 Labels、 High-Low Temperature Oven、 Refrigerator、 Constant Voltage Power Supply (DC) , Desk Lamp, etc.

4. Sampling Plan and Reference Standard

4.1.1 According to GB/T 2828.1---2003/ISO2859-1:1999, single sampling under normal inspection, general inspection level II.

Item of Inspection	Times of Sampling	AQL Judgment
Cosmetic	II Single Sampling	MA=0.4 MI=1.5
Mechanical	N=3	C=0
Functional	II Single Sampling	MA=0.4 MI=1.5

4.1.2 GB/T 2828.1---2003/ISO2859-1:1999 Counting and sampling procedures and sampling table for Batch-to-Batch Inspection.

4.1.3 GB/T 1619.96 Test method for TN LCD.

4.1.4 GB/T 12848.91 General Specification for STN LCD.

4.1.5 GB2421-89 Basic Environmental Test Procedures for Electrical and Electronic Products

4.1.6 IPC-A-610C Acceptance Condition for Electrical Assemblies.

5. Inspection Condition and Inspection Reference

5.1 The ambient temperature and humidity are $25 \pm 5^{\circ}\text{C}$ and $45 \pm 20\%\text{RH}$ respectively, and the ambient luminance should be more than $300\text{cd}/\text{cm}^2$. The distance between inspector's eyes and the LCD panel should be 30cm away. Normally we inspect products with reflected light, when we inspect the LCD produces with backlight turned on, the ambient luminance should be less than $100\text{cd}/\text{cm}^2$.

5.2 The LCD should be test with 45° both left and right side, $0-45^{\circ}$ both upside

and downside (if for STN product, $-20-55^{\circ}$ is needed) .

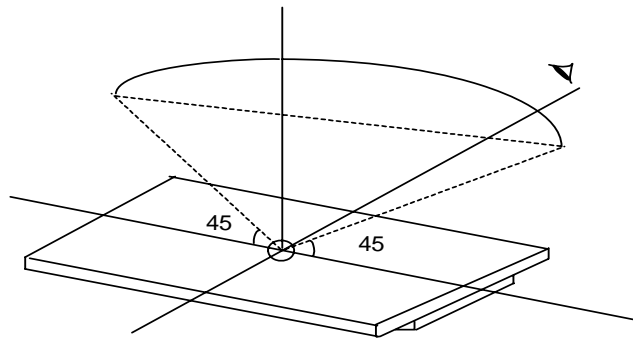

5.3 Definition of VA

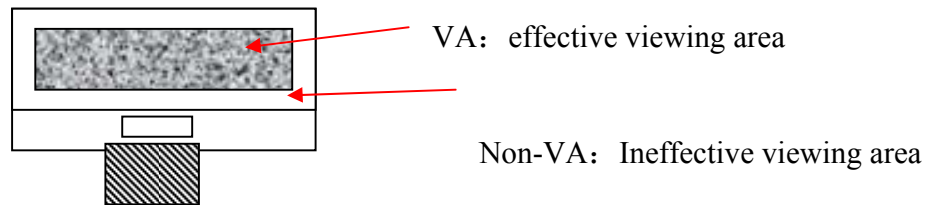

5.4 Inspection with viewed eyes (not including defect size measure by magnifiers) .

5.5 Electrical property

Inspect with the test jig to meet with the requirement indicated in the approved documents, including the pattern design and the display performance.

5.5.1 Testing voltage (V)

5.5.1.1 According to the inspection of test jig and production specification the test voltage setting is $V_{op} \pm 0.3V$ when the V_{op} is under $9.0V$, and $V_{op} \pm 3\%V_{op}$ when the V_{op} is above $9.0V$.



5.5.1.2 As per the product with the fixed voltage the test voltage setting is same as V_{op} and keeps the constant voltage through the internal circuit. And the limited sample on the voltage range is needed if necessary.

5.5.2 Current Consumption (I) : refer to product document and approval drawing to confirm it.

6. Inspection Item and Acceptance Standard

6.1 Outer dimension: For the outer dimension and the sizes which could influence the assembly at the customer's side, it should be in accordance to the approval drawing, and it belongs to the major defect.

6.2 Functional Test:

No.	Item	Description	MAJ	MIN	Accept standard
6.2.1	Missing Segment	Any missing segment caused by an open circuit; Any missing COM, pattern, dot or segment caused by an open circuit or poor crossover contact 	✓		Rejected
6.2.3	No display/no action	No segment is displayed when the product is connected correctly.	✓		Rejected
6.2.4	Display error/abnormal	The display pattern and display order is not as required under the normal scanning procedure.	✓		Rejected
6.2.5	Viewing angle wrong	The direction with the best display of patterns should be as customer required (or refer to the approval samples)	✓		Rejected
6.2.6	Display dim/dark	The contrast of LCD is too dark or too dim under normal operation	✓		Beyond the voltage tolerance, Rejected
6.2.7	Slow response	Response of some segments is different with others when turned on or off the LCD	✓		Rejected
6.2.8	Extra segment	Display of wiring, or extra pattern, caused by wrong alignment or insufficient corrosion..		✓	refer to spot/line standard
6.2.9	Dim segment	Under the normal voltage, the contrast of segment are uneven		✓	Reject or refer to samples
6.2.10	PI black/white spot	Partial black and white spot are visible while changing display content due to the PI layer defective		✓	refer to the spot/line criteria for the visible spots when display image stopped, others O
6.2.11	pinhole/white spot	The phenomena of missing patterns when turned on caused by missing of ITO fragment.  $d = (X+Y)/2$		✓	refer to spot/line standard

6.2.12	Pattern distortion	Width of pattern displayed is wider , narrower or deformed from the specifications caused by wrong alignment, i.e. extra heave or missing: $ Ia-Ib \leq 1/4W$ (W is the normal width)		√	Acceptable $ Ia-Ib > 1/4W$, rejected
6.2.13	High current	the current is bigger than regulated value.		√	Rejected

6.3 LCD Visual Defect

6.3.1 Dot defect(defined within VA, out of VA spots not accounted)

Defect item	Average diameter (d)	Accept numbers	MAJ	MIN
Spot defect (black spot, foreign material, nick, scratches, LC defect)	$d \leq 0.2$	3		√
	$0.2 < d \leq 0.25$	2		
	$0.25 < d \leq 0.30$	1		

6.3.2 Line defect(defined within VA, out of VA spots not accounted)

Defective item	length(L)	width(W)	Accept numbers	MAJ	MIN
line defect (scratch, liner foreign material)	≤ 5.0	≤ 0.02	3		√
	≤ 3.0	≤ 0.03	3		
	≤ 3.0	≤ 0.05	1		

note: 1. If the width is bigger than 0.1mm, it can be treated as spot defect.

6.3.3 Polarizer Air Bubble (defined within VA, out of VA spots not accounted)

Defective item	Average diameter (d)	Accept numbers	MAJ	MIN
polarizer Air Bubble, Concave-Convex Dot	$d \leq 0.3$	3		√
	$0.3 < d \leq 0.5$	2		
	$0.5 < d \leq 0.8$	1		

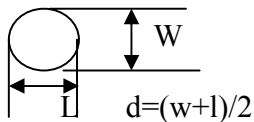

6.3.4 Damaged(For the products with LCD edge expose to outside without mental frame, including products in COG, with H/S or assembled with backlight)

No.	Item	Acceptance Standard	MAJ	MIN
6.3.4.1		(mm)		√

	Chip on lead 	X	$\leq 1/8L$			
		Y	$\leq 1/3W$			
		Z	$\leq 1/2t$			
		Accept number	2			
		When $Y \leq 0.2\text{mm}$, neglect the length of X, chip on the side without lead, and not perforated, when $X \leq 1/10L$, $Y \leq 1/2W$ max, accept.				
6.3.4.2	chip on corner(ITO lead) 		(mm)	MAJ	MIN	
		X	Not enter into frame epoxy and touch the lead			
		Y				
		Z	$\leq t$			√
		Accept numbers	2			
Chips on corner refer to 6.3.4.3 and must be out of the frame epoxy. If chips on lead, refer to 6.3.4.1						
6.3.4.3	Chip on sealed area (outer chip) 		(mm)	MAJ	MIN	
		X	$\leq 1/8 L$			
		Y	$\leq 1/2H$			
		z	$\leq 1/2t$			
		Accept numbers	2			√
The standard for inner chip on sealed area is same as the standard for outer. If chip on the opposite side of ITO lead, the value Y refer to 6.3.4.1 for the chip on the side without lead.						
note: t---glass thickness, L---length, H---The distance between the LCD edge to the inner of LCD frame epoxy. W—The width of ITO lead						

6.3.5 Others

No.	Item	Description	MAJ	MIN	Accept standard
6.3.5.1	Newton/B/G color uniformity not good	There exists more than one color on one product or same batch.		√	Reject or refer to limited sample
6.3.5.2	Leakage(LC)	/	√		Rejected
6.3.5.3	No protective film	/		√	Rejected

6.4 Backlight components

No.	Item	Description	MAJ	MIN	Accept standard
6.4.1	Backlight not work, wrong color	/	√		Rejected
6.4.2	Color deviation	Turn backlight, the color differ from the sample, do not match the drawing after testing		√	Refer to sample and drawing
6.4.3	Brightness deviation	Turn on backlight, the brightness is differ from the sample, or do not match the drawing after testing, or over $\pm 30\%$ compare with sample if drawing not specified.		√	Refer to sample and drawing
6.4.4	Uneven brightness	Turn on the backlight, the brightness is uneven on the same LED and beyond the specification of drawing.		√	Refer to sample and drawing
6.4.5	Spot/line scratch	There is stain, scratches on backlight when turn on.		√	Refer to 6.3.1/6.3.2

6.5 Mental frame

No.	Item	Description	MAJ	MIN	Accept standard
6.5.1	material/surface	Mental frame/surface approach inconsistent with specification.	√		Rejected
6.5.2	Twist not qualified/without twisting	Twist method/direction wrong, not twist as required	√		Rejected
6.5.3	Oxidized steak, paint stripped, color changed, dented mark, scratches	1.Oxidized steak on the surface of the metal frame;2. front surface paint scratch to substrate, the stripped spot $\leq 0.8\text{mm}$ and exceed 3 areas;3.line defect in length $\leq 5.0\text{mm}$ and width $\leq 0.05\text{mm}$ exceed 2 areas, front dent, bubble and side surface have paint stripping to substrate $\leq 1.0\text{mm}$ exceed 3 areas, line defect in width $\leq 0.05\text{mm}$ exceed 3 areas.		√	Rejected
6.5.4	Burred	Burr is too long, enter into viewing area		√	Rejected

6.6 PCB/COB

No.	Item	Description	MAJ	MIN	Accept standard
6.6.1	Epoxy Cover	1. The Pad within the round white mark is exposed to outside.		√	Rejected

	Improper	<ol style="list-style-type: none"> 2. The height of epoxy covers beyond document /drawing specification. 3. The epoxy should be covered within the white round mark and the maximum overage is 2mm more than the radius of white mark. 4. Clear liner mark on COB surface or pinhole that it is possible to penetrate through the epoxy to chip. 5. The pinhole diameter over 0.25mm or other material on COB surface. 			
6.6.2	PCB cosmetic defect	<ol style="list-style-type: none"> 1. PCB pad surface can not be oxidized or contaminated. 2. PCB can not appear bubbles after through the reflow oven. 3. Copper lead due to the PCB green oil drop or scratches. If repaired by adding the green oil, circuit diameter Φ can not over 1.3mm, other diameter Φ can not over 2.6mm, total less than 10 areas. Otherwise reject. 		√	Rejected
6.6.3	Components error	<ol style="list-style-type: none"> 1. PCB components inconsistent with drawing. Wrong components, more or less pa, polar reverse (The bias circuit of LCD voltage or BL limit current value adjustment is not controlled if not special specified.) 2. The JUMP short of PCB should be consistent of the mechanical drawing. 3. The components is specially required by the customers and specified in mechanical drawing / technical documents, the components specification should be conformed to technique demand. Otherwise rejected 		√	Rejected

6.7 SMT part (Refer to IPC-A-610C if not specified)

No.	Item	Description	MAJ	MIN	Accept standard
6.7.1	Soldering defect	Cold soldering, false solder, missing solder, tin crack, tin un-dissolved happened with soldering.		√	Rejected
6.7.2	Solder ball/splash	Solder ball/tin dross drop lead to solder short.		√	Rejected

6.7.3	DIP parts	DIP parts, keypad, connection appear floating and tilted.		√	Rejected
6.7.4	Spot weld shape	The spot weld should be inner dent, can not form to cover solder or less solder or icicle, otherwise reject		√	Rejected
6.7.5	Component foot exposed	For the DIP type components, after soldered, 0.5~2mm component foot must be remained, and should not damage the solder surface nor fully covered the component foot. Otherwise rejected.		√	Rejected
6.7.6	Appearance poor	After soldering, the solder residues appear brown or black. PCB solder spot remained white mist residues after clean.		√	Rejected

6.8 Heating pressure part (including H/S, FPC, etc.)

No.	Item	Description	MAJ	MIN	Accept standard
6.8.1	Out of specification		√		Rejected
6.8.2	Size/position	The size of heating material should be within the specification of the drawing, the contact area of conducted material should be attached more than 1/2 of the body (ITO, PDA, etc)		√	Acceptable
6.8.3	Heat pressure dirty	The obstacle existed in non-conductive heating area and not lead to short, or existed in conductive area but the obstacle is less than 50% of pressure area, it is acceptable.		√	Acceptable
6.8.4	Folding defect			√	Refer to limited sample

6.9 Connector and other parts

No.	Item	Description	MAJ	MIN	Accept standard
6.9.1	Specification improper	The specification of connector and other components do not conform to the drawing as required.	√		Rejected
6.9.2	Position and order	Solder position and Pin 1 should be consistent with the drawing.		√	Rejected
6.9.3	Cosmetic	1. The body of outer component and the PIN has flux. 2. The deformation bigger of PIN connector is bigger than 1/2 of PIN width.		√	Rejected

6.10 General cosmetic

No.	Item	Description	MAJ	MIN	Accept standard
6.10.1	Connection material	Copper lead on FPC pad or the pin terminal of H/S, FFC and damaged. FPC,FFC, COF,H/S connected material curved (except for original) . FPC、PCB pad is bigger than 1PIN width. FPC/FFC material segment, crease exceed the specification.		√	Rejected
6.10.2	Stiffing type defect	Stiffening tape is not covered or fully covered the product's circuit needs to be protected. (Like H/S, FFC, FPC) or cover to the output pin.		√	Rejected
6.10.3	Visual dirty	Dirty on surface of finished products, residual glue, solder spatter or solder ball remain on non-soldered area of PCB/COB. The defective mark or label on product does not remove.		√	Rejected
6.10.4	Assembly black spot	The spot or black dots found after assembly the products with backlight or diffuser.		√	Refer to 6.3.1
6.10.5	Product mark	Part number and batch mark is not conformed with the technical requirement and position, not clear or without mark.		√	Rejected
6.10.6	Inner packing	Packing is inconsistent with requirement, short or over load, Packing is inconsistent with shipment mark/ order demand.		√	Rejected

7. Reality test

Test item	Condition	Time(hrs)	Accept standard
High Temp Storage	80°C	120	No abnormalities in functions and appearance
High Temp Operating	70°C	120	
Low Temp Storage	-30°C	120	
Low Temp Operating	-20°C	120	
Temp& Humidity Test	40°C/90%RH	120	
Temp Shock	-20°C ← 25°C → +70°C (30 min ← 5 min → 30min)	10 cycles	

- Note: ①The customer should inform the special requirements on the reliability test to Gemini when starting the project.
- ②For high/low temperature test under both storage and operating condition, the temperature is referred to the product specification.
- ③For temperature test $\pm 5^{\circ}\text{C}$ deviation could be accepted.

8. Packing

- 8.1 Product packing must meet the requirement of packing design. The label should be qualified by QA department and it includes the Item No., specification sheet, quantity and production date. Incomplete or mistake is regarded as not qualified.
- 8.2 When the safety of the packing exist the problems, including shock resistance, moisture resistance, anti-ESD and press resistance, it is regarded as not qualified.
- 8.3 When customer has special requirement on packing, which is confirmed and accepted by Gemini, inspect and release the products as customer required.
- 8.4 For RoHS or non-RoHS products it should be distinguished with obvious label. Currently we adopt the “RoHS” label for all the products meet the RoHS compliance, or using the labels / marks as the customer required.

9. Others

- 9.1 For unregulated and compromised items, reference shall be taken to mutual agreements and limit samples.