



HY15P41

Datasheet

8-Bit RISC-like Mixed Signal Microcontroller

Embedded 18-Bit $\Sigma\Delta$ ADC

Table of Contents

1.	特點	5
2.	引腳定義	6
2.1.	引腳定義及標記信息說明.....	8
3.	應用電路	14
3.1.	3*PIR application (Pyro-electric infrared detector).....	14
3.2.	Smart Pressure sensor application	14
3.3.	Battery voltage, current and temperature detection application	14
4.	功能概述	15
4.1.	內部方塊圖	15
4.2.	相關說明與支援文件.....	15
4.3.	Clock System	16
4.4.	Reset.....	17
4.5.	Power System	18
4.6.	Σ ADC Network.....	19
4.7.	GPIO System	20
4.8.	Watch Dog System	20
4.9.	8-bit Timer A1 System.....	21
4.10.	16-bit Timer B System.....	21
4.11.	EUART System	22
4.12.	I ² C System	23
5.	暫存器列表.....	24

HY15P41

Embedded 18-Bit Σ ADC 8-Bit RISC-like Mixed Signal Microcontroller

6.	電氣特性	26
6.1.	Recommended operating conditions	26
6.2.	Internal RC Oscillator	26
6.3.	Supply current into VDD excluding peripherals current	28
6.4.	Port4	30
6.5.	Rest(Brownout)	31
6.6.	Power System	32
6.7.	Σ ADC, Power Supply and recommended operating conditions	34
6.8.	Build-In EPROM(BIE)	40
7.	訂貨資訊	41
8.	封裝型式資訊	42
8.1.	SOP8(S008)	42
8.2.	SOP16(S016)	46
8.3.	DFN12(AS12)	49
9.	修訂記錄	51

注意：

- 1、本說明書中的內容，隨著產品的改進，有可能不經過預告而更改。請客戶及時到本公司網站下載更新 <http://www.hycontek.com>。
- 2、本規格書中的圖形、應用電路等，因第三方工業所有權引發的問題，本公司不承擔其責任。
- 3、本產品在單獨應用的情況下，本公司保證它的性能、典型應用和功能符合說明書中的條件。當使用在客戶的產品或設備中，以上條件我們不作保證，建議客戶做充分的評估和測試。
- 4、請注意輸入電壓、輸出電壓、負載電流的使用條件，使 IC 內的功耗不超過封裝的容許功耗。對於客戶在超出說明書中規定額定值使用產品，即使是瞬間的使用，由此所造成的損失，本公司不承擔任何責任。
- 5、本產品雖內置防靜電保護電路，但請不要施加超過保護電路性能的過大靜電。
- 6、本規格書中的產品，未經書面許可，不可使用在要求高可靠性的電路中。例如健康醫療器械、防災器械、車輛器械、車載器械及航空器械等對人體產生影響的器械或裝置，不得作為其部件使用。
- 7、本公司一直致力於提高產品的品質和可靠度，但所有的半導體產品都有一定的失效概率，這些失效概率可能會導致一些人身事故、火災事故等。當設計產品時，請充分留意冗餘設計並採用安全指標，這樣可以避免事故的發生。
- 8、本規格書中內容，未經本公司許可，嚴禁用於其他目的之轉載或複製。

HY15P41

Embedded 18-Bit $\Sigma\Delta$ ADC
8-Bit RISC-like Mixed Signal Microcontroller

1. 特點

- 8-Bit RISC-like 微控制器，具有 66 條高性能指令集 H08C(同 H08A)
- 22-Bit $\Sigma\Delta$ ADC 類比數位轉換器
 - 梳狀濾波器採二階設計，轉換頻率達 7.8Ksps
 - 取樣頻率 500KHz
 - 超取樣頻率設置 64~32768
 - 全差動輸入信號
 - 測量範圍的零點調整
 - 信號放大
x1/4,x1/2,x1,x2,x4,x8,x16
 - 測量信號支援多通道輸入
 - 低溫飄係數
 - 內置絕對溫度感測器
- 內部電源系統
 - 內置 LDO 線性穩壓電源 VDDA
 - ◆ 內部類比電路或外部傳感器電壓源
 - ◆ 多段可輸出電壓設置，可外灌輸入電壓
 - ◆ 低操作功耗與低溫飄係數
- 計時器
 - Watch Dog
 - ◆ 復位事件與中斷事件
 - 8-bit Timer
 - ◆ 中斷事件
 - ◆ 比較事件
 - 16-bit Timer
 - ◆ 16-Bit PWM 輸出
 - ◆ 兩個 8-Bit PWM 輸出
 - ◆ 中斷事件
- 工作電壓與操作溫度範圍
 - V_{DD} : 2.2V ~ 5.5V
 - V_{DDA} : 2.4V ~ 4.5V
 - - 40°C ~ 85°C
- 工作頻率
 - 內建高精度 HAO 震盪器
2MHz/4MHz/8MHz
 - 內建低功耗 LPO 震盪器 14.5KHz
- 記憶體型式
 - 2KW OTP 程式記憶體
 - 128B 資料記憶體
 - 6 層堆棧
 - Build-In EPROEM
 - ◆ VPP 外部燒錄電壓 8.5V
 - ◆ 64W EPROM 記憶體
- 引腳特色
 - 具 10mA 驅動能力
- 復位機制
 - Power On Reset
 - Brown Out Reset
 - Watch Dog Reset
 - Stack Over Reset
- 串列通訊 EUART 模組
- I²C通信(Master/Slave mode)模組

功能列表

Model No.	VDD	System Clock (Hz)	Program Memory (word)	SRAM (byte)	BIE (word)	ADC ENOB (bit x ch)	Sample Rate (sps)	TPS	I/O	Timer (bit x ch)	PWM (bit x ch)	Serial Interface (I/F x ch)	Package
HY15P41	2.2V~5.5V	14.5K~8M	2K	128	64	18-bit x 5	15~7.8K	yes	1xI + 5xIO	8-bit x 1 16-bit x 1	8-bit x 2 16-bit x 1	EUART x 1 I2C x 1	SOP8 SOP16 DFN12

HY15P41

Embedded 18-Bit $\Sigma\Delta$ ADC

8-Bit RISC-like Mixed Signal Microcontroller

2. 引腳定義

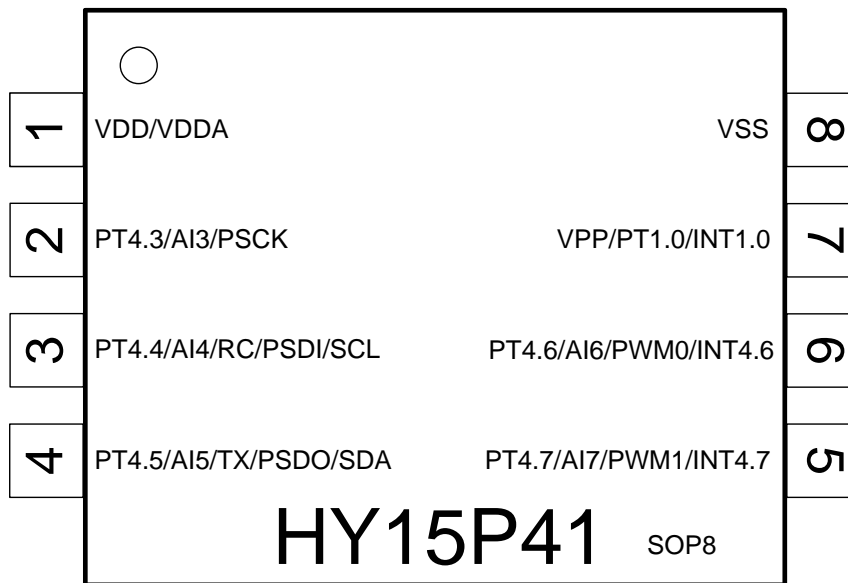

Figure 2-1 HY15P41 SOP8 引腳圖

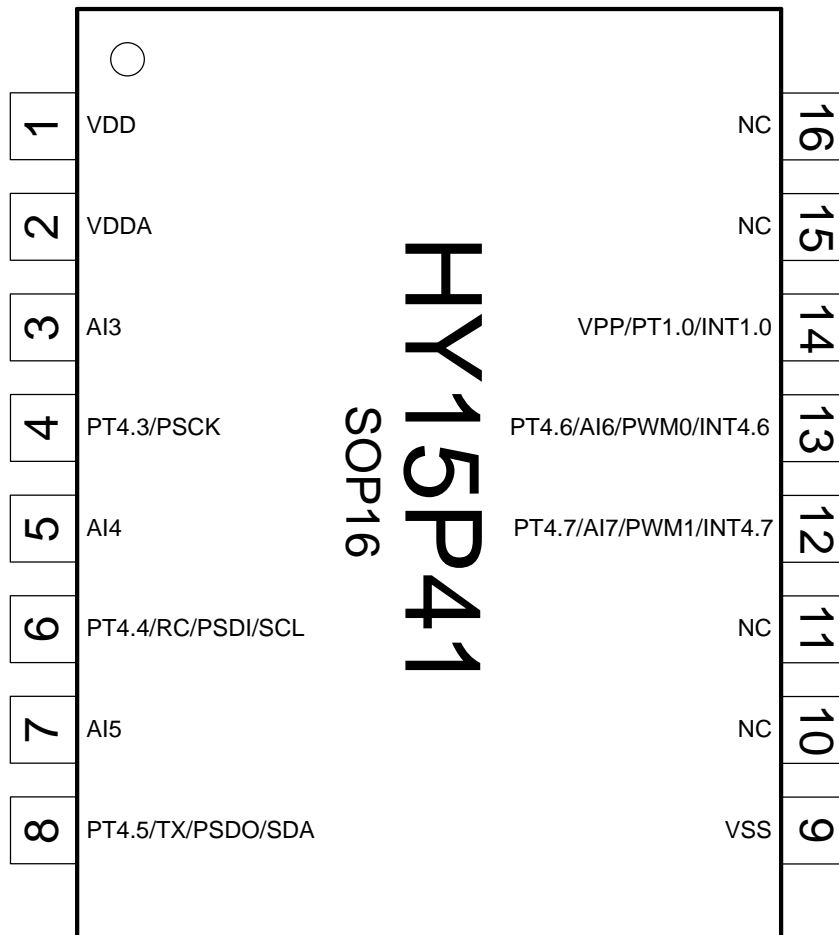

Figure 2-2 HY15P41 SOP16 引腳圖

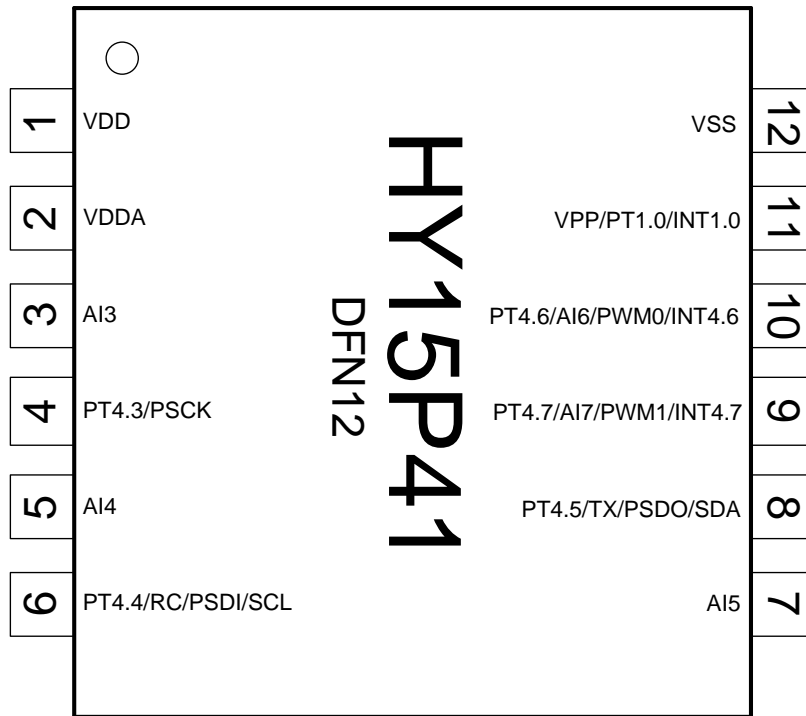

Figure 2-3 HY15P41 DFN12 引腳圖

HY15P41

Embedded 18-Bit Σ ADC

8-Bit RISC-like Mixed Signal Microcontroller



2.1. 引腳定義及標記信息說明

2.1.1. SOP8 引腳定義

“I”：輸入,“O”：輸出,“A”：類比,“S”：史密斯觸發,“C”：CMOS I/O,“P”：電壓源,“/”：或,“X”：可忽略					
封裝	引腳名稱	設計		描述	
		型式	緩衝		
SOP8					
1	VDD	P	P	晶片工作電壓源輸入引腳	
1	VDDA	P	P	LDO 線性穩壓電源輸出引腳	
2	PT4.3/AI3/PSCK	PT4.3	I/O	S/C	數位輸入 / 輸出引腳
		AI3	A	A	類比輸入通道
		PSCK	I	S	OTP 讀/寫介面 PSCK 接口
3	PT4.4/AI4/RC/PSDI/SCL	PT4.4	I/O	C	數位輸入 / 輸出引腳
		AI4	A	A	類比輸入通道
		RC	I	S	EUART 訊介面 RC 接口
		PSDI	I	S	OTP 讀/寫介面 PSDI 接口
		SCL	I/O	S	I2C 通訊介面時鐘接口
4	PT4.5/AI5/TX/PSDO/SDA	PT4.5	I/O	C	數位輸入 / 輸出引腳
		AI5	A	A	類比輸入通道
		TX	O	S	EUART 訊介面 TX 接口
		PSDO	I/O	S	OTP 讀/寫介面 PSDO 接口
		SDA	I/O	S	I2C 通訊介面數據接口
5	PT4.7/AI7/PWM1/INT4.7	PT4.7	I/O	C	數位輸入 / 輸出引腳
		AI7	A	A	類比輸入通道
		PWM1	O	C	TMB 的 PWM1 輸出引腳
		INT4.7	I	S	外部中斷源
6	PT4.6/AI6/PWM0/INT4.6	PT4.6	I/O	C	數位輸入 / 輸出引腳
		AI6	A	A	類比輸入通道
		PWM0	O	C	TMB 的 PWM0 輸出引腳
		INT4.6	I	S	外部中斷源
7	PT1.0/VPP/INT1.0	PT1.0	I	S	數位輸入
		VPP	P	P	晶片燒錄電壓源輸入引腳
		INT1.0	I	S	外部中斷源

HY15P41

Embedded 18-Bit $\Sigma\Delta$ ADC

8-Bit RISC-like Mixed Signal Microcontroller



8	VSS	P	P	晶片工作電壓源接地端引腳
---	-----	---	---	--------------

表 2-1 引腳定義與功能說明

HY15P41

Embedded 18-Bit Σ ADC
8-Bit RISC-like Mixed Signal Microcontroller

2.1.2. SOP16 引腳定義

“I”：輸入,“O”：輸出,“A”：類比,“S”：史密斯觸發,“C”：CMOS I/O,“P”：電壓源,“/”：或,“X”：可忽略				
封裝	引腳名稱	設計		描述
		型式	緩衝	
SOP16				
1	VDD	P	P	晶片工作電壓源輸入引腳
2	VDDA	P	P	LDO 線性穩壓電源輸出引腳
3	AI3	A	A	類比輸入通道
4	PT4.3/PSCK	PT4.3 I/O PSCK I	S/C S	數位輸入 / 輸出引腳 OTP 讀/寫介面 PSCK 接口
5	AI4	A	A	類比輸入通道
6	PT4.4/RC/PSDI/SCL	PT4.4 I/O RC I PSDI I SCL I/O	C S S S	數位輸入 / 輸出引腳 EUART 訊介面 RC 接口 OTP 讀/寫介面 PSDI 接口 I2C 通訊介面時鐘接口
7	AI5	A	A	類比輸入通道
8	PT4.5/TX/PSDO/SDA	PT4.5 I/O TX O PSDO I/O SDA I/O	C S S S	數位輸入 / 輸出引腳 EUART 訊介面 TX 接口 OTP 讀/寫介面 PSDO 接口 I2C 通訊介面數據接口
9	VSS	P	P	晶片工作電壓源接地端引腳
12	PT4.7/AI7/PWM1/INT4.7	PT4.7 I/O AI7 A PWM1 O INT4.7 I	C A C S	數位輸入 / 輸出引腳 類比輸入通道 TMB 的 PWM1 輸出引腳 外部中斷源
13	PT4.6/AI6/PWM0/INT4.6	PT4.6 I/O AI6 A PWM0 O INT4.6 I	C A C S	數位輸入 / 輸出引腳 類比輸入通道 TMB 的 PWM0 輸出引腳 外部中斷源
14	PT1.0/VPP/INT1.0			

HY15P41

Embedded 18-Bit $\Sigma\Delta$ ADC

8-Bit RISC-like Mixed Signal Microcontroller

		PT1.0	I	S	數位輸入
		VPP	P	P	晶片燒錄電壓源輸入引腳
		INT1.0	I	S	外部中斷源
Others	NC		-	-	Not Connect

表 2-2 引腳定義與功能說明

2.1.3. DFN12 引腳定義

“I”：輸入，“O”：輸出，“A”：類比，“S”：史密斯觸發，“C”：CMOS I/O，“P”：電壓源，“/”：或，“X”：可忽略					
封裝	引腳名稱	設計		描述	
		型式	緩衝		
DFN12					
1	VDD	P	P	晶片工作電壓源輸入引腳	
2	VDDA	P	P	LDO 線性穩壓電源輸出引腳	
3	AI3	A	A	類比輸入通道	
4	PT4.3/PSCK	PT4.3 PSCK	I/O I	S/C S	數位輸入 / 輸出引腳 OTP 讀/寫介面 PSCK 接口
5	AI4	AI4	A	A	類比輸入通道
6	PT4.4/RC/PSDI/SCL	PT4.4 RC PSDI SCL	I/O I I I/O	C S S S	數位輸入 / 輸出引腳 EUART 訊介面 RC 接口 OTP 讀/寫介面 PSDI 接口 I2C 通訊介面時鐘接口
7	AI5	AI5	A	A	類比輸入通道
8	PT4.5/TX/PSDO/SDA	PT4.5 TX PSDO SDA	I/O O I/O I/O	C S S S	數位輸入 / 輸出引腳 EUART 訊介面 TX 接口 OTP 讀/寫介面 PSDO 接口 I2C 通訊介面數據接口
9	PT4.7/AI7/PWM1/INT4.7	PT4.7 AI7 PWM1 INT4.7	I/O A O I	C A C S	數位輸入 / 輸出引腳 類比輸入通道 TMB 的 PWM1 輸出引腳 外部中斷源
10	PT4.6/AI6/PWM0/INT4.6	PT4.6 AI6 PWM0 INT4.6	I/O A O I	C A C S	數位輸入 / 輸出引腳 類比輸入通道 TMB 的 PWM0 輸出引腳 外部中斷源
11	PT1.0/VPP/INT1.0	PT1.0	I	S	數位輸入

HY15P41

Embedded 18-Bit $\Sigma\Delta$ ADC

8-Bit RISC-like Mixed Signal Microcontroller

		VPP	P	P	晶片燒錄電壓源輸入引腳
		INT1.0	I	S	外部中斷源
12	VSS		P	P	晶片工作電壓源接地端引腳

表 2-2 引腳定義與功能說明

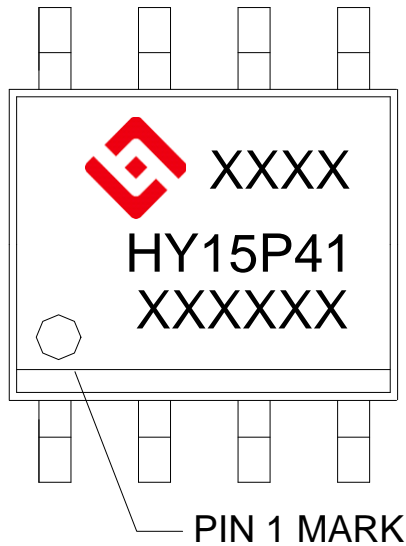

- 紘康 Logo + 生產識別碼
- 產品名稱 : HY15P41
- 產品批號

HY15P41

Embedded 18-Bit $\Sigma\Delta$ ADC
8-Bit RISC-like Mixed Signal Microcontroller

3. 應用電路

3.1. 3*PIR application (Pyro-electric infrared detector)

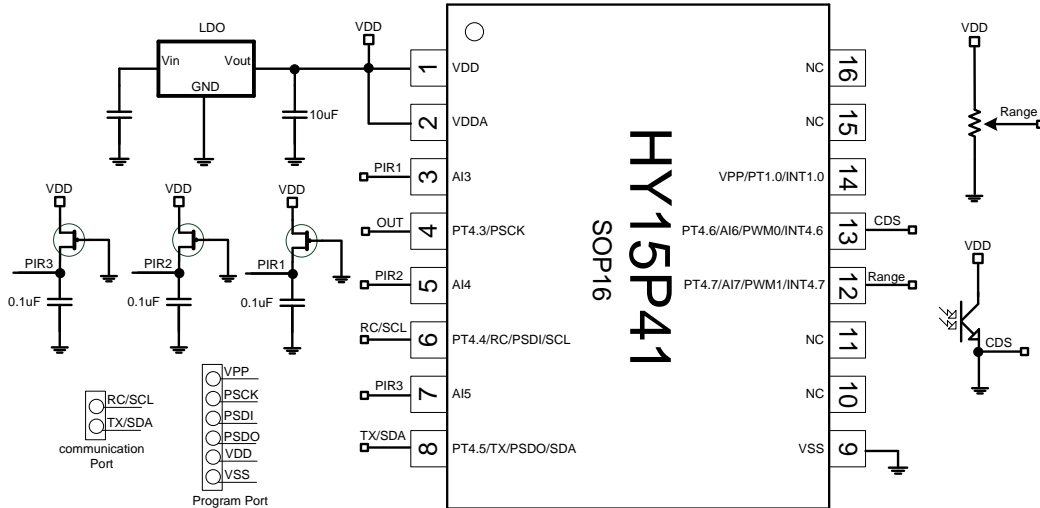

Figure 3-1 3*PIR 應用電路

3.2. Smart Pressure sensor application



圖 3-2 Smart Pressure Sensor 應用電路

3.3. Battery voltage, current and temperature detection application

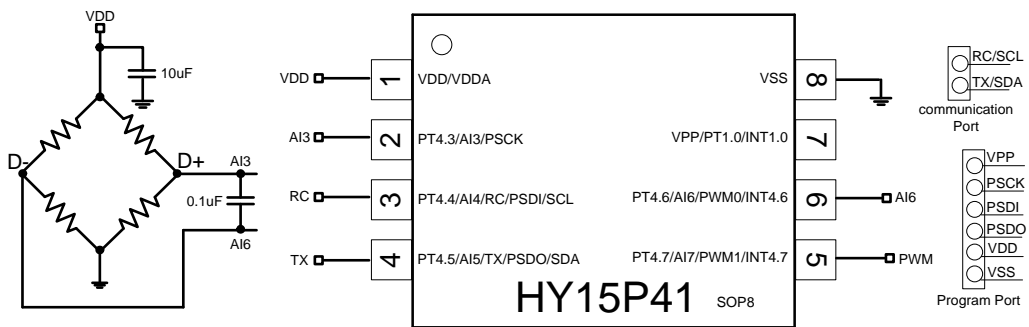
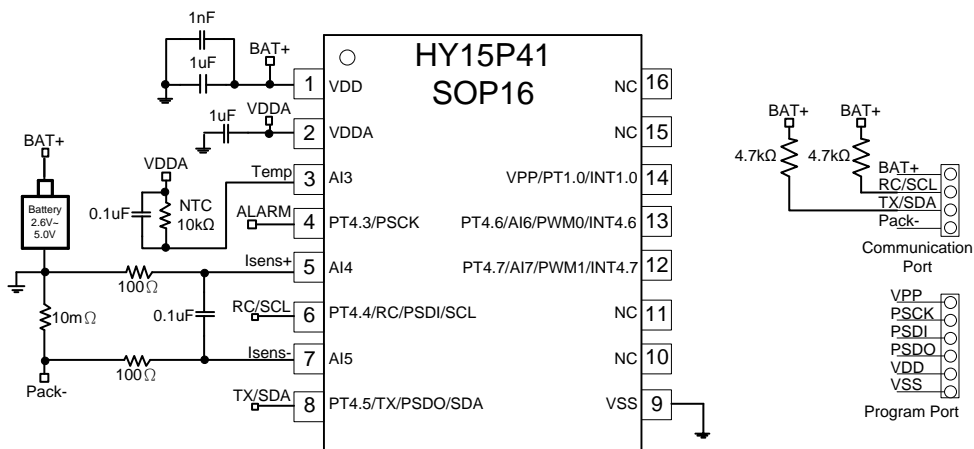

Figure 3-3 Battery voltage, current and temperature detection 應用電路

4. 功能概述

4.1. 内部方块图

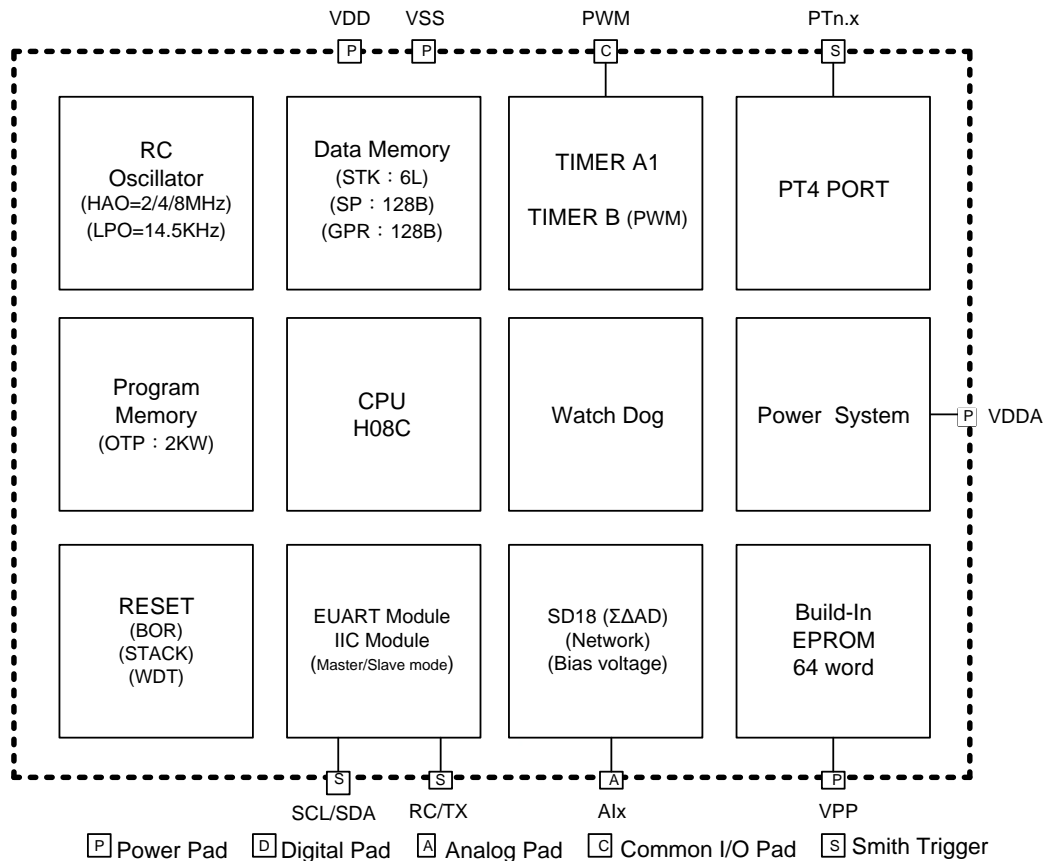

Figure 4-1 HY15P41 内部方块图

4.2. 相關說明與支援文件

晶片功能相關使用說明書

DS-HY15P41 HY15P41 說明書

UG-HY15S41 HY15P41 使用說明書

開發工具相關使用說明書

APD-HYIDE002 HY15P 系列開發工具軟體使用說明書

APD-HYIDE005 HY15S41 開發工具硬體使用說明書

APD-HYIDE003 HY15P 系列 HexLoader 說明書

APD-HYIDE013 HY10000-WK08C 整合型燒錄器使用說明書

BDI-HY15P41 HY15P41 個別產品的裸片打線資訊

4.3. Clock System

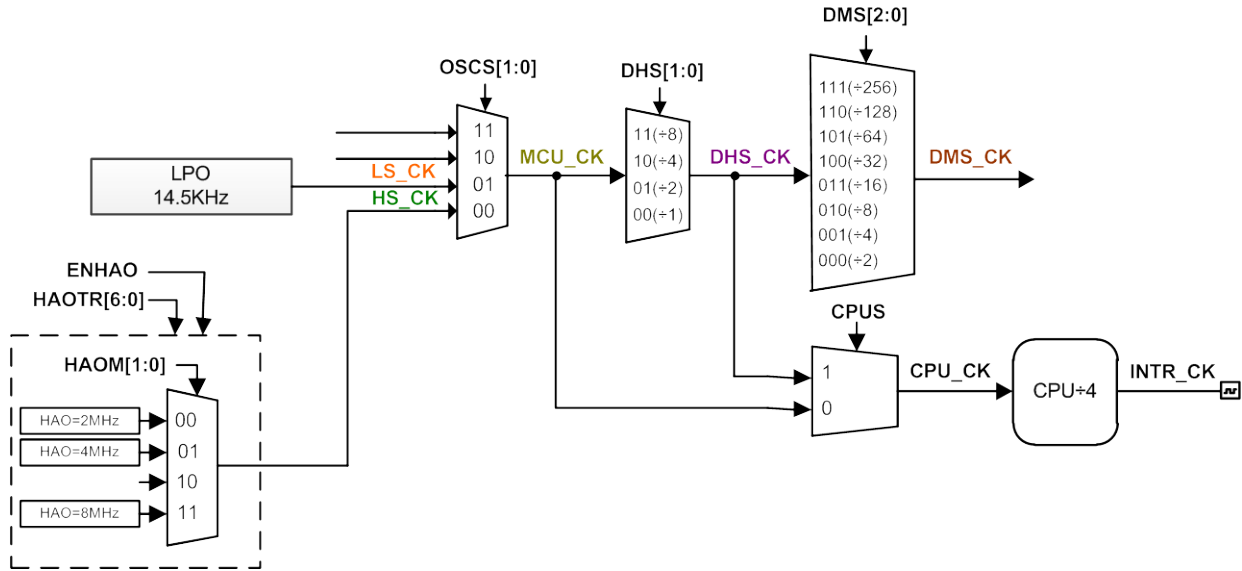

Figure 4-2 Clock System 方塊圖(一)

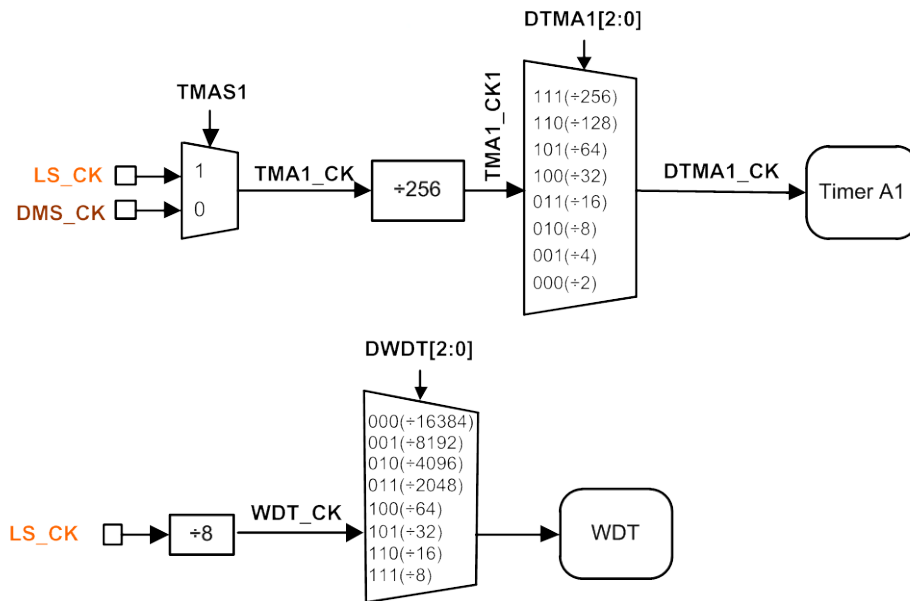

Figure 4-3 Clock System 方塊圖(二)

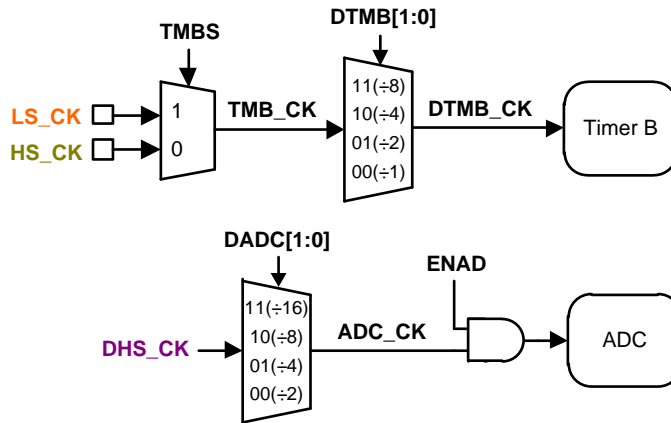

Figure 4-4 Clock System 方塊圖(三)

4.4. Reset

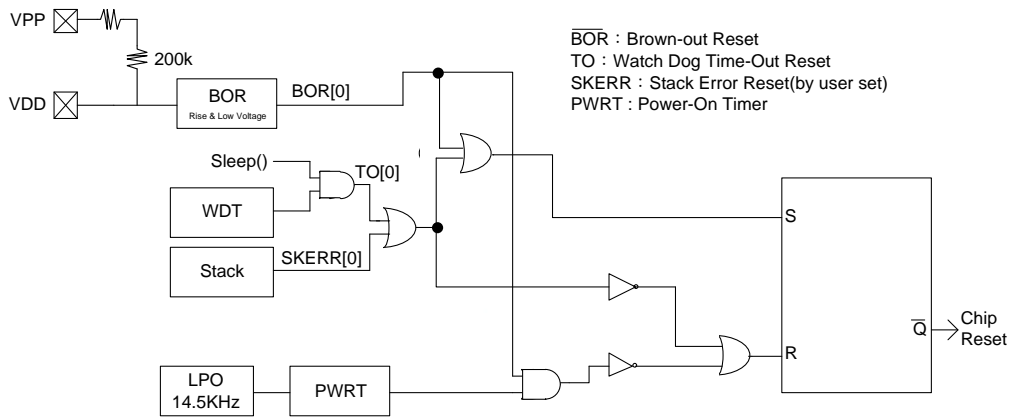

Figure 4-5 Reset 方塊圖

4.5. Power System

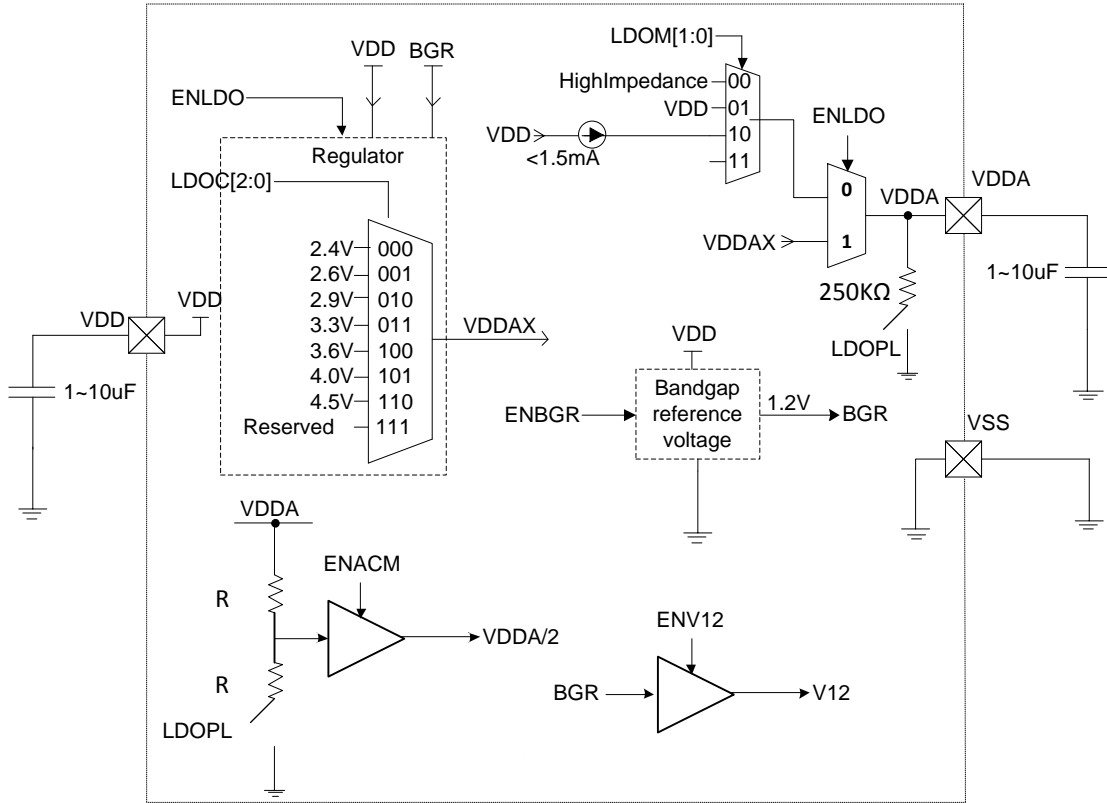

Figure 4-6 Power System 方塊圖

4.6. $\Sigma\Delta$ ADC Network

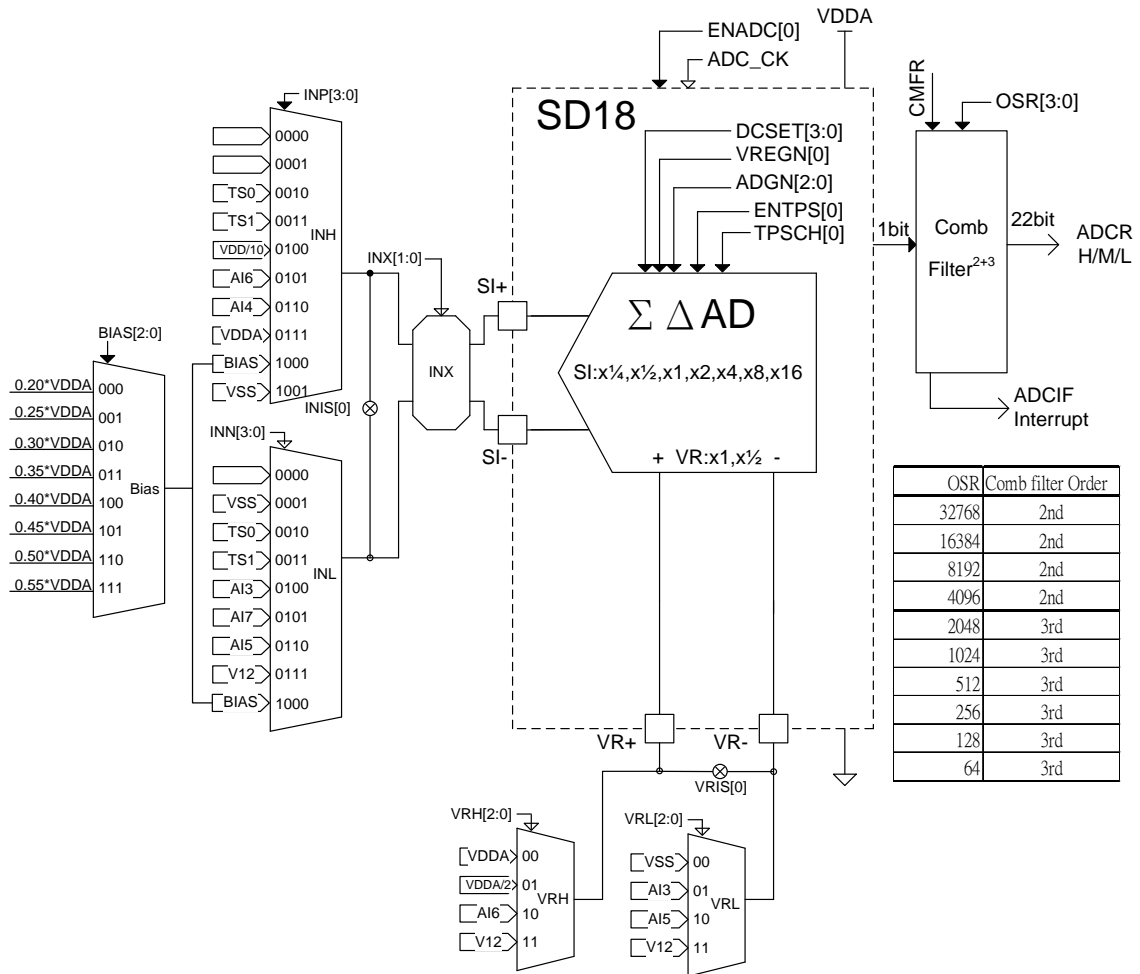

Figure 4-7 SD18 Network

4.7. GPIO System

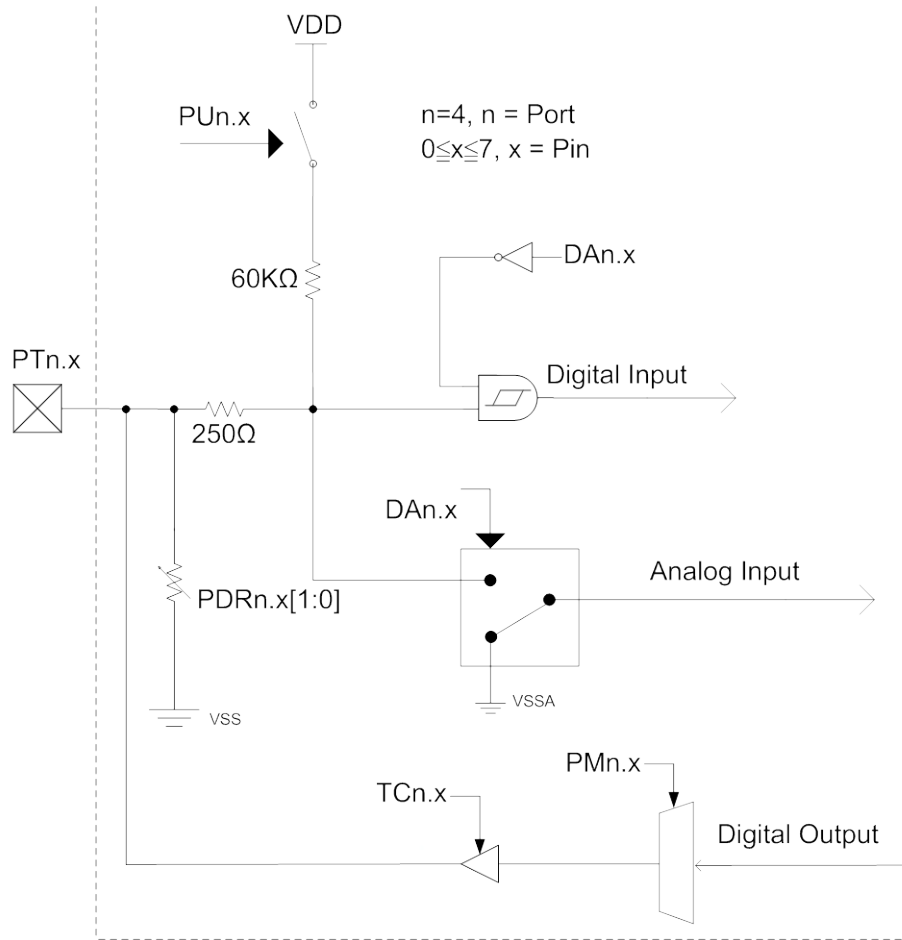

Figure 4-8 GPIO 方塊圖

4.8. Watch Dog System

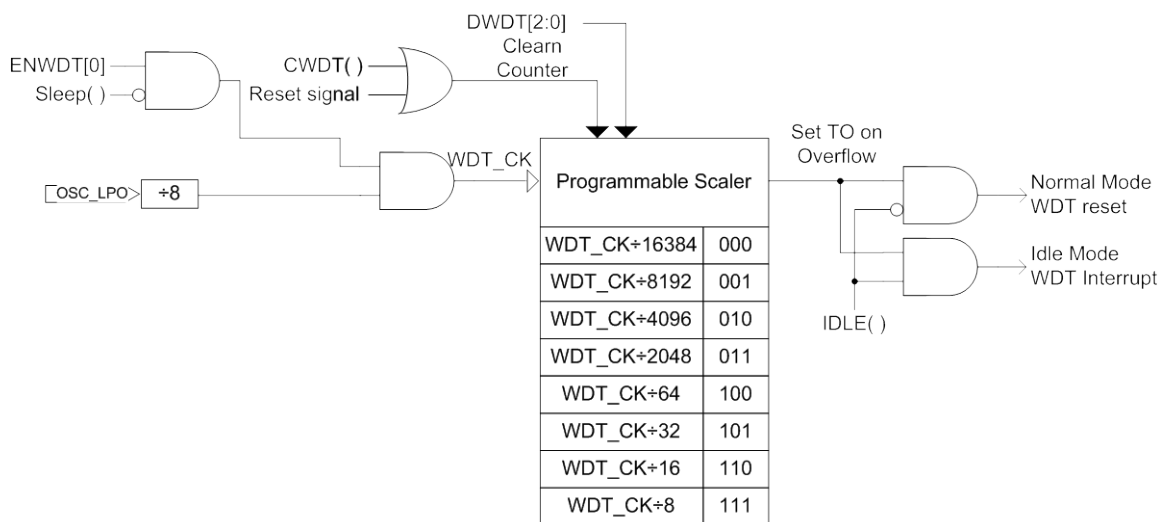

Figure 4-9 Watch Dog 方塊圖

4.11. EUART System

EUART TRANSMIT BLOCK DIAGRAM

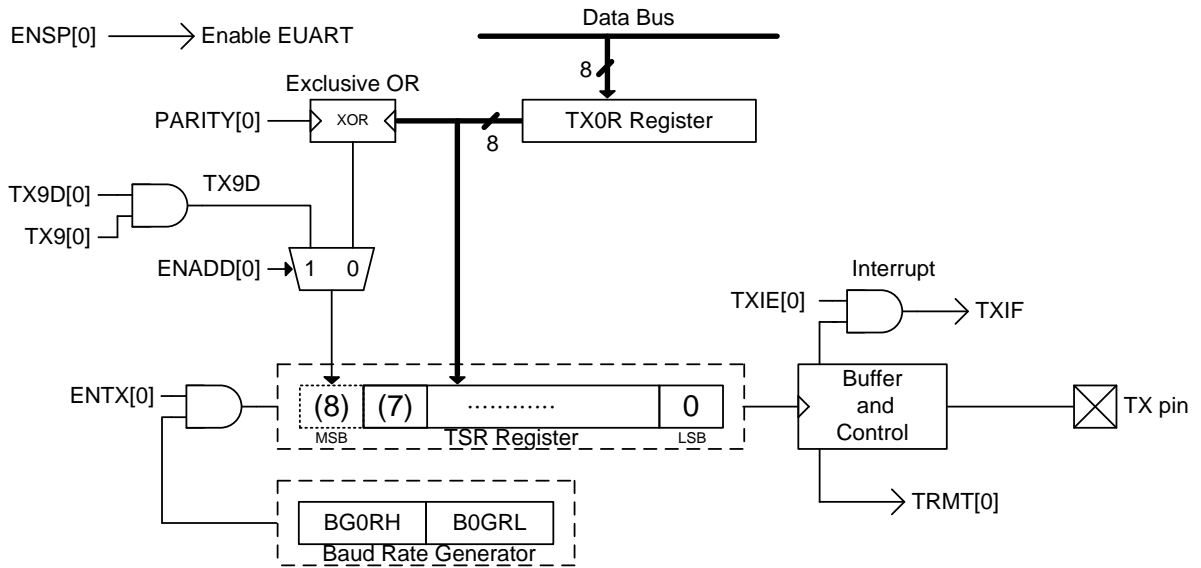
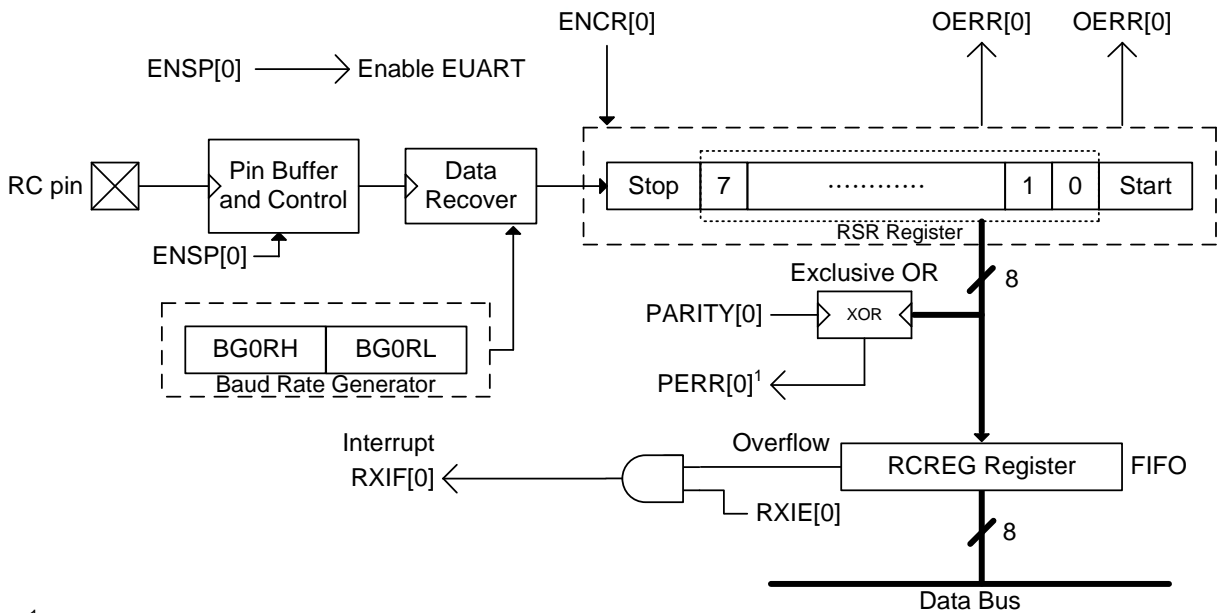

Figure 4-12 EUART 傳送方塊圖

EUART 8-BITS RECEIVE BLOCK DIAGRAM



¹Don't care PERR[0] state of 8-bits receive mode

Figure 4-13 EUART 8-bits 接收方塊圖

HY15P41

Embedded 18-Bit Σ ADC 8-Bit RISC-like Mixed Signal Microcontroller



5. 暫存器列表

"r" no use, "w" read/write, "w" write, "r" read, "r0" only read 0, "r1" only read 1, "w0" only write 0, "w1" only write 1
"\$" for event status, "-" unimplemented bit, "x" unknown, "u" unchanged, "d" depends on condition

Address	Name	Bit 7	Bit 6	Bit 5	Bit 4	Bit 3	Bit 2	Bit 1	Bit 0	ARST	IRST	R/W	
000h	INDF0	Contents of FSR0 to address data memoryvalue of FSR0 not changed								xxxx xxxx	uuuu uuuu	*****	
001h	POINC0	Contents of FSR0 to address data memoryvalue of FSR0 post-incremented								xxxx xxxx	uuuu uuuu	*****	
002h	PODEC0	Contents of FSR0 to address data memoryvalue of FSR0 post-decremented								xxxx xxxx	uuuu uuuu	*****	
003h	PRINC0	Contents of FSR0 to address data memoryvalue of FSR0 pre-incremented								xxxx xxxx	uuuu uuuu	*****	
004h	PLUSW0	Contents of FSR0 to address data memoryvalue of FSR0 offset by W								xxxx xxxx	uuuu uuuu	*****	
005h	INDF1	Contents of FSR1 to address data memoryvalue of FSR1 not changed								xxxx xxxx	uuuu uuuu	*****	
006h	POINC1	Contents of FSR1 to address data memoryvalue of FSR1 post-incremented								xxxx xxxx	uuuu uuuu	*****	
007h	PODEC1	Contents of FSR1 to address data memoryvalue of FSR1 post-decremented								xxxx xxxx	uuuu uuuu	*****	
008h	PRINC1	Contents of FSR1 to address data memoryvalue of FSR1 pre-incremented								xxxx xxxx	uuuu uuuu	*****	
009h	PLUSW1	Contents of FSR1 to address data memoryvalue of FSR1 offset by W								xxxx xxxx	uuuu uuuu	*****	
00Ah	INDF2	Contents of FSR2 to address data memoryvalue of FSR2 not changed								xxxx xxxx	uuuu uuuu	*****	
00Bh	POINC2	Contents of FSR2 to address data memoryvalue of FSR2 post-incremented								xxxx xxxx	uuuu uuuu	*****	
00Ch	PODEC2	Contents of FSR2 to address data memoryvalue of FSR2 post-decremented								xxxx xxxx	uuuu uuuu	*****	
00Dh	PRINC2	Contents of FSR2 to address data memoryvalue of FSR2 pre-incremented								xxxx xxxx	uuuu uuuu	*****	
00Eh	PLUSW2	Contents of FSR2 to address data memoryvalue of FSR2 offset by W								xxxx xxxx	uuuu uuuu	*****	
010h	FSR0L	Indirect Data Memory Address Pointer 0 Low Byte,FSR0[7:0]								xxxx xxxx	uuuu uuuu	*****	
012h	FSR1L	Indirect Data Memory Address Pointer 0 Low Byte,FSR1[7:0]								xxxx xxxx	uuuu uuuu	*****	
014h	FSR2L	Indirect Data Memory Address Pointer 0 Low Byte,FSR2[7:0]								xxxx xxxx	uuuu uuuu	*****	
016h	TOSH	-	-	-	-	TOS[11:8]			..xx xxxx	..uu uuuu	-,-,*****		
017h	TOSL	Top-of-Stack Low Byte (TOS<7:0>)								xxxx xxxx	uuuu uuuu	*****	
018h	SKCN	SKFL	SKUN	SKOV	-	-	SKPRT[2:0]		000. 0000	u\$. \$\$\$	rw 0,rw 0,rw 0,-,*,**		
01Ah	PCLATH	-	-	-	-	PC[11:8]			..00 0000	..00 0000	*****		
01Bh	PCLATL	PC Low Byte for PC<7:0>								0000 0000	0000 0000	*****	
01Dh	TBLPTRH	-	-	-	-	TBLPTR[11:8]			..xx xxxx	..uu uuuu	-,-,*****		
01Eh	TBLPTRL	Program Memory Table Pointer Low Byte (TBLPTR<7:0>)								xxxx xxxx	uuuu uuuu	*****	
01Fh	TBLDH	Program Memory Table Latch High Byte								xxxx xxxx	uuuu uuuu	*****	
020h	TBLDL	Program Memory Table Latch Low Byte								xxxx xxxx	uuuu uuuu	*****	
021h	PRODH	Product Register of Multiply High Byte								xxxx xxxx	uuuu uuuu	*****	
022h	PRODL	Product Register of Multiply Low Byte								xxxx xxxx	uuuu uuuu	*****	
023h	INTE0	GIE	TA1CIE	ADIE	WDTIE	TB1IE			E0IE	0000 0000	0uuu uuuu	*****	
024h	INTE1	TA1IE		TXIE	RCIE	I2CERIE	I2CIE			0000 0000	uuuu uuuu	*****	
026h	INTF0	-	TA1CIF	ADIF	WDTIF	TB1IF			E0IF	.000 0000	..uuu uuuu	*****	
027h	INTF1	TA1IF		TXIF	RCIF	I2CERIF	I2CIF			0000 0000	uuuu uuuu	***** r,r,*	
029h	WREG	Working Register								xxxx xxxx	uuuu uuuu	*****	
02Bh	MSTAT	-	-	-	C	DC	N	OV	Z	...x xxxx	...u uuuu	-,-,*****	
02Ch	PSTAT	POR	PD	TO	IDL	-	SKERR	-	-	\$000 \$00.	uu\$u u\$u.	rw0,rw0,rw0,rw0,rw0,rw0,-	
02Eh	BIECN	1	-	-	-	-	-	BIEWR	BIERD	1... \$000	1... \$uuu	r1,-,-, r1,*	
030h	BIEARL	-	-	BIE Address Register as BIEAL[5:0]						xxxx xxxx	uuuu uuuu	*****	
031h	BIERH	BIE High Byte Data Register								xxxx xxxx	uuuu uuuu	*****	
032h	BIERL	BIE Low Byte Data Register								xxxx xxxx	uuuu uuuu	*****	
033h	PWRCN	ENBGR	LDOC[2:0]		LDOM[0]	LDOM	ENLDO	CSFON		0000 0000	uuuu u00u	*****,w r0,w r0,*	
034h	OSCCN0	OSCS[1:0]		DHS[1:0]	DMS[2:0]			CUPS		0000 0000	uuuu uuuu	*****	
035h	OSCCN1	CCOPT	DADC[1:0]		DTMB[1:0]	TMBS		-		0000 0000	uuuu uuuu	*****,-	
036h	OSCCN2					HAOM[1:0]		ENHAO		0000 0001	uuuu uu01	*****	
037h	WDTCN					ENWDT	DWDWT[2:0]			0000 0000	uuuu \$000	-,* rw 1,*	
03Ah	AD1H	ADC1 conversion high byte data register								..00 0000	..uu uuuu	-,-,*****	
03Bh	AD1M	ADC1 conversion middle byte data register								0000 0000	uuuu uuuu	*****	
03Ch	AD1L	ADC1 conversion low byte data register								0000 0000	uuuu uuuu	*****	
03Dh	AD1CN0	ENAD1	-	-	OSR[3:0]			CMFR		000. 0000	uuu. uuuu	*****	
03Eh	AD1CN1	-	-	VREGN	ADGN[2:0]					xxxx xxxx	uuuu uuuu	*****	
03Fh	AD1CN2	-	BIAS[2:0]			DCSET[3:0]					xxxx xxxx	uuuu uuuu	*****
040h	AD1CN3	INF[3:0]			INN[3:0]					xxxx xxxx	uuuu uuuu	*****	
041h	AD1CN4	VRH[1:0]	VRL[1:0]		INX[1:0]	VRIS	INIS		0010 0000	uuuu uuuu	*****		
042h	AD1CN5	ENACM	ENV12	VCMIS	LDOPL	ENBS	-	ENTPS	TPSCH	0000 0000	uuuu uuuu	*****	
043h	CSFCN0	SKRST	HAOTR[6:0]								.1... ..	*****	
044h	TMA1CN	ENTMA1	TMACL1	TMAS1	DTMA1[2:0]		-	-	-	0000 00..	u0uu uu..	*,rw 1,*	
045h	TMA1R	TMA1 counter Register								0000 0000	uuuu uuuu	rw0,rw0,rw0,rw0,rw0,rw0,rw0	
046h	TMA1C	TMA1C counter Register								0000 0000	uuuu uuuu	rw0,rw0,rw0,rw0,rw0,rw0,rw0	

Table 5-1 資料記憶體列表

HY15P41

Embedded 18-Bit ΣADC 8-Bit RISC-like Mixed Signal Microcontroller



"--no use,""read/write,"w"write,"r"read,"r0"only read 0,"r1"only read 1,"w0"only write 0,"w1"only write 1
"\$"for event status,"u"unimplemented bit,"x"unknown,"u"unchanged,"d"depends on condition

Address	Name	Bit 7	Bit 6	Bit 5	Bit 4	Bit 3	Bit 2	Bit 1	Bit 0	ARST	IRST	R/W		
047h	AIXM1	APDR3[1:0]		-	-	-	-	-	-	0000 0000	uuuu uuuu	***** 1 1 1 1 1 1 1		
048h	AIXM2	-	-	-	-	-	-	APDR4[1:0]		0000 0000	uuuu uuuu	***** 1 1 1 1 1 1 1		
04Eh	TB1Flag	-	-	PWM6A	PWM5A	PWM4A	PWM3A	PWM2A	PWM1A	..00 0000	..uu uuuu	-,-,r,r,r,r,r,r,f		
04Fh	TB1CN0	ENTB1	TB1M[1:0]		TB1RT[1:0]		TB1CL	-	-	0000 0000	uuuu u00u	*****,rw 1,* 1 1 1 1 1 1 1		
050h	TB1CN1	PA1IV	PWMA1[2:0]			PA0IV	PWMA0[2:0]			0000 0000	uuuu uuuu	***** 1 1 1 1 1 1 1		
051h	TB1RH	TimerB1 counter Register [15:8]								xxxx xxxx	uuuu uuuu	r,r,r,r,r,r,r,r		
052h	TB1RL	TimerB1 counter Register [7:0]								xxxx xxxx	uuuu uuuu	r,r,r,r,r,r,r,r		
053h	TB1COH	TimerB1 counter Condition Register [15:8]								xxxx xxxx	uuuu uuuu	***** 1 1 1 1 1 1 1		
054h	TB1COL	TimerB1 counter Condition Register [7:0]								xxxx xxxx	uuuu uuuu	***** 1 1 1 1 1 1 1		
055h	TB1C1H	TimerB1 counter Condition Register [15:8]								xxxx xxxx	uuuu uuuu	***** 1 1 1 1 1 1 1		
056h	TB1C1L	TimerB1 counter Condition Register [7:0]								xxxx xxxx	uuuu uuuu	***** 1 1 1 1 1 1 1		
057h	TB1C2H	TimerB1 counter Condition Register [15:8]								xxxx xxxx	uuuu uuuu	***** 1 1 1 1 1 1 1		
058h	TB1C2L	TimerB1 counter Condition Register [7:0]								xxxx xxxx	uuuu uuuu	***** 1 1 1 1 1 1 1		
059h	TCCN0	-	TC1S[1:0]		-	-	-	-	-	0000 0000	uuuu uuuu	***** 1 1 1 1 1 1 1		
061h	CFG	-	-	-	-	-	GCRST	ENI2CT	ENI2C	0000 0000uuu	-,-,-,-,* 1 1 1 1 1 1 1		
062h	ACT	SLAVE	ADR10	SLAVE24	I2CER	START	STOP	I2CINT	ACK	0000 0000	uuuu uuuu	***** 1 1 1 1 1 1 1		
063h	STA	MACTF	SACTF	RDBF	RWF	DF	ACKF	GCF	ARBF	0001 0000	uuuu uuuu	***** 1 1 1 1 1 1 1		
064h	CRG	CRG[7:0]								0000 0000	uuuu uuuu	***** 1 1 1 1 1 1 1		
065h	TOC	I2CTF	DI2C[2:0]			I2CTL[3:0]					0000 0000	uuuu uuuu	***** 1 1 1 1 1 1 1	
066h	RDB	RDB[7:1]							RDB[0]		xxxx xxxx	uuuu uuuu	***** 1 1 1 1 1 1 1	
067h	TDB0	TDB0[7:1]							TDB0[0]		xxxx xxxx	uuuu uuuu	***** 1 1 1 1 1 1 1	
068h	SID0	SID0[7:1],The corresponding address of the 7-bit mode								SID0V[0]	0000 0000	uuuu uuuu	***** 1 1 1 1 1 1 1	
069h	UROCN	ENSP	ENTX	TX9	TX9D	PARITY	-	-	WUE	0000 0..0	uuuu u..u	***** 1 1 1 1 1 1 1		
06Ah	UR0STA	-	RC9D	PERR	FERR	OERR	RCIDL	TRMT	ABDOVF	..00 0010	..uuu uuuu	-,-,r,r,r,r,r,r,rw 0		
06Bh	BA0CN	-	-	-	-	ENCR	RC9	ENADD	ENABD 0000 uuuu	-,-,-,-,* 1 1 1 1 1 1 1		
06Ch	BG0RH	-	-	-	Baud Rate Generator Register High Byte						...x xxxx	...u uuuu	***** 1 1 1 1 1 1 1	
06Dh	BG0RL	Baud Rate Generator Register Low Byte								xxxx xxxx	uuuu uuuu	***** 1 1 1 1 1 1 1		
06Eh	TX0R	UART Transmit Register								xxxx xxxx	uuuu uuuu	***** 1 1 1 1 1 1 1		
06Fh	RCREG	UART Receive Register								xxxx xxxx	uuuu uuuu	r,r,r,r,r,r,r,r		
070h	PT1									PT1.0	xxxx xxxx	xxxx xxxx	***** 1 1 1 1 1 1 1	
074h	PT1M1	-	-	-	-	-	INTEG0[1:0]			0000 0000	uuuu uuuu	***** 1 1 1 1 1 1 1		
075h	PT4	PT4.7	PT4.6	PT4.5	PT4.4	PT4.3						xxxx xxxx	xxxx xxxx	***** 1 1 1 1 1 1 1
076h	TRISC4	TC4.7	TC4.6	TC4.5	TC4.4	TC4.3						0000 0000	uuuu uuuu	***** 1 1 1 1 1 1 1
077h	PT4DA	DA4.7	DA4.6	DA4.5	DA4.4	DA4.3						0000 0000	uuuu uuuu	***** 1 1 1 1 1 1 1
078h	PT4PU	PU4.7	PU4.6	PU4.5	PU4.4	PU4.3						0000 0000	uuuu uuuu	***** 1 1 1 1 1 1 1
079h	PT4PD1	PDR4.3[1:0]		-	-	-	-	-	-	0000 0000	uuuu uuuu	***** 1 1 1 1 1 1 1		
07Ah	PT4PD2	PDR4.7[1:0]		PDR4.6[1:0]		PDR4.5[1:0]		PDR4.4[1:0]		0000 0000	uuuu uuuu	***** 1 1 1 1 1 1 1		
07Bh	PT4INT	INTG4.7	INTG4.6								0000 0000	uuuu uuuu	***** 1 1 1 1 1 1 1	
07Ch	PT4INTE	INTE4.7	INTE4.6								0000 0000	uuuu uuuu	***** 1 1 1 1 1 1 1	
07Dh	PT4INTF	INTF4.7	INTF4.6								0000 0000	uuuu uuuu	***** 1 1 1 1 1 1 1	
07Eh	PT4M2	-	PM4.7[0]	-	PM4.6[0]	-	-	-	-	0000 0000	uuuu uuuu	***** 1 1 1 1 1 1 1		
080h ~ 0FFh	SRAM as 128Byte									uuuu uuuu	uuuu uuuu	***** 1 1 1 1 1 1 1		

Table 5-2 資料記憶體列表(續)

HY15P41

Embedded 18-Bit Σ ADC
8-Bit RISC-like Mixed Signal Microcontroller



6. 電氣特性

Absolute maximum ratings over operating free-air temperature (unless otherwise noted)

Voltage applied at V_{DD} to V_{SS}	-0.2 V to 6.0 V
Voltage applied to any pin	-0.2 V to $V_{DD} + 0.3$ V
Voltage applied to V_{PP} pin	-0.2 V to 8.75 V
Diode current at any device terminal	± 2 mA
Operating temperature range	-40°C to 85°C
Storage temperature, T_{stg} : (unprogrammed device)	-55°C to 150°C
(programmed device)	-40°C to 85°C
Total power dissipation.....	0.5w
Maximum output current sink by any port I/O pin.....	.25mA

6.1. Recommended operating conditions

$T_A = -40^\circ\text{C} \sim 85^\circ\text{C}$, unless otherwise noted

Sym.	Parameter	Test Conditions	Min.	Typ.	Max.	unit
V_{DD}	Digital Supply Voltage	All digital peripherals and CPU	2.2		5.5	V
V_{DDA}	Analog Supply Voltage	Analog peripherals	2.4		4.5	V
V_{SS}	Supply Voltage		0		0	

6.2. Internal RC Oscillator

$T_A = 25^\circ\text{C}$, $V_{DD} = 3.0\text{V}$, unless otherwise noted

Sym.	Parameter	Test Conditions	Min.	Typ.	Max.	unit
HAO(2MHz)	High Speed Oscillator frequency	ENHAO[0]=1, HAOM[1:0]=00	-20%	2.0	+20%	MHz
HAO(4MHz)	High Speed Oscillator frequency	ENHAO[0]=1, HAOM[1:0]=01	-20%	4.0	+20%	MHz
HAO(8MHz)	High Speed Oscillator frequency	ENHAO[0]=1, HAOM[1:0]=11	-20%	8.0	+20%	MHz
LPO	Low Power Oscillator frequency	V_{DD} supply voltage be enable LPO	-20%	14.5	+20%	KHz

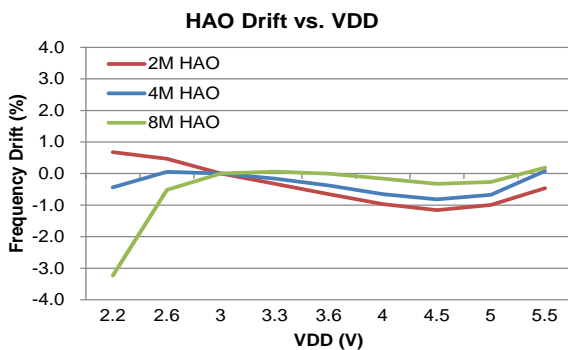

Figure 6.2-1 HAO vs. VDD

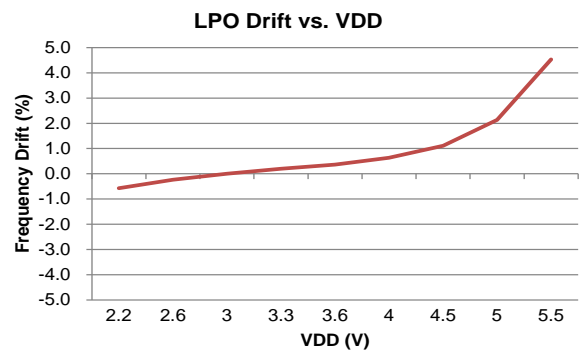

Figure 6.2-2 LPO vs. VDD

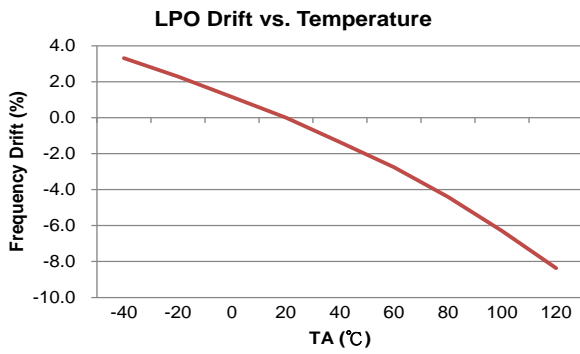

Figure 6.2-3 LPO vs. Temperature

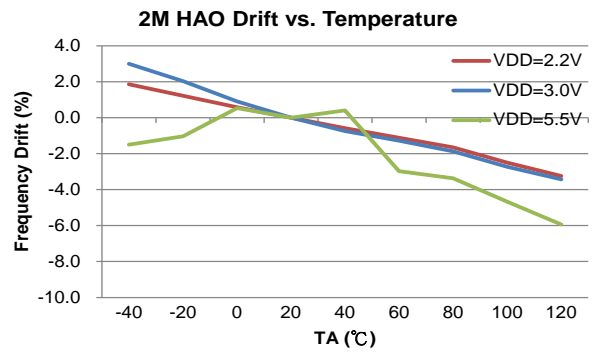

Figure 6.2-4 HAO(2.0MHz) vs. Temperature

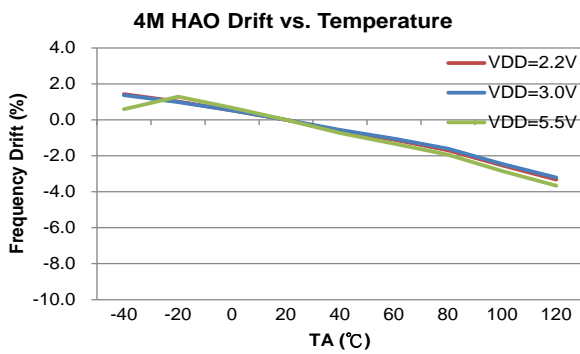

Figure 6.2-5 HAO(4.0MHz) vs. Temperature

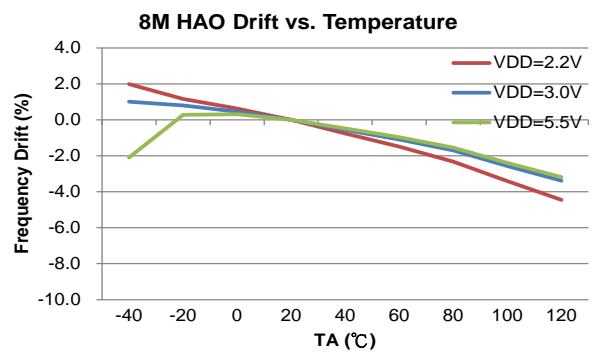

Figure 6.2-6 HAO(8.0MHz) vs. Temperature

6.3. Supply current into VDD excluding peripherals current

$T_A = 25^\circ\text{C}, V_{DD} = 3.0\text{V}, \text{OSC_LPO} = 14.5\text{KHz}$, unless otherwise noted

Sym.	Parameter	Test Conditions	Min.	Typ.	Max.	unit
I_{AM1}	Active mode 1	OSC_CY = off, OSC_HAO = 8MHz, CPU_CK = 8MHz		600	1000	μA
I_{AM2}	Active mode 2	OSC_CY = off, OSC_HAO = 4MHz, CPU_CK = 4MHz		320	650	μA
I_{AM3}	Active mode 3	OSC_CY = off, OSC_HAO = 2MHz, CPU_CK = 2MHz		210	450	μA
I_{AM4}	Active mode 4	OSC_CY = off, OSC_HAO = 2MHz, CPU_CK = 1MHz		160	350	μA
I_{LP1}	Low Power 1	OSC_CY = off, OSC_HAO = off, CPU_CK = LPO,		2	5	μA
I_{LP2}	Low Power 2	OSC_CY = off, OSC_HAO = off, CPU_CK = LPO, Idle state		1.0	2.5	μA
I_{LP3}	Low Power 3	OSC_CY = off, OSC_HAO = off, CPU_CK = off, Sleep state		0.25	1.0	μA

$T_A = 25^\circ\text{C}, V_{DD} = 5.5\text{V}, \text{OSC_LPO} = 14.5\text{KHz}$, unless otherwise noted

Sym.	Parameter	Test Conditions	Min.	Typ.	Max.	unit
I_{AM1}	Active mode 1	OSC_CY = off, OSC_HAO = 8MHz, CPU_CK = 8MHz		1200	1800	μA
I_{AM2}	Active mode 2	OSC_CY = off, OSC_HAO = 4MHz, CPU_CK = 4MHz		720	1200	μA
I_{AM3}	Active mode 3	OSC_CY = off, OSC_HAO = 2MHz, CPU_CK = 2MHz		500	1000	μA
I_{AM4}	Active mode 4	OSC_CY = off, OSC_HAO = 2MHz, CPU_CK = 1MHz		400	800	μA
I_{LP1}	Low Power 1	OSC_CY = off, OSC_HAO = off, CPU_CK = LPO,		4	10	μA
I_{LP2}	Low Power 2	OSC_CY = off, OSC_HAO = off, CPU_CK = LPO, Idle state		2.5	5	μA
I_{LP3}	Low Power 3	OSC_CY = off, OSC_HAO = off, CPU_CK = off, Sleep state		0.4	2	μA

OSC_HAO : Internal High Accuracy Oscillator frequency.

CPU_CK : CPU core work frequency.

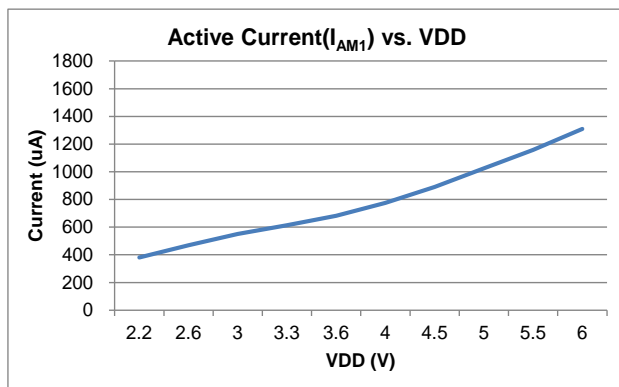

Figure 6.3-1 I_{AM1} vs. VDD

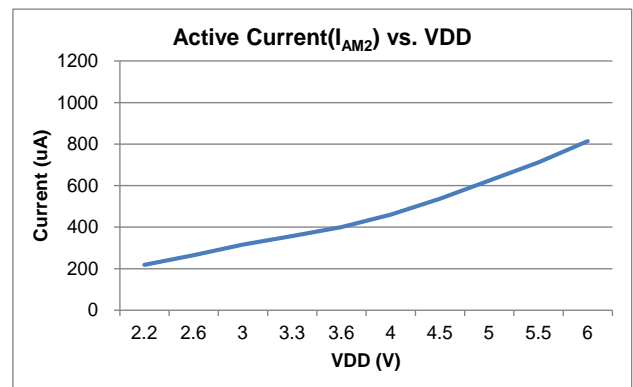

Figure 6.3-2 I_{AM2} vs. VDD

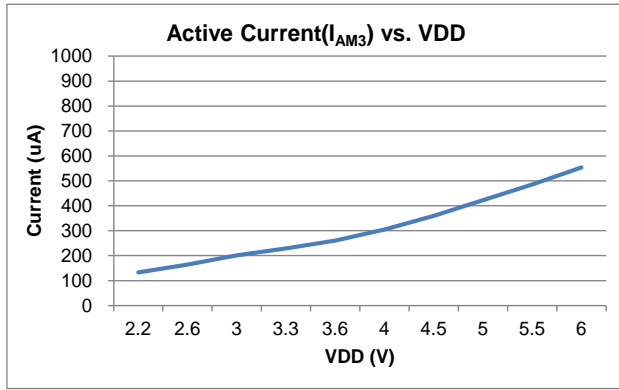

Figure 6.3-3 I_{AM3} vs. VDD

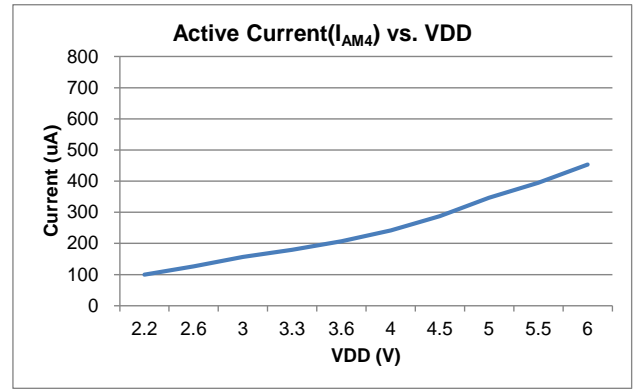

Figure 6.3-4 I_{AM4} vs. VDD

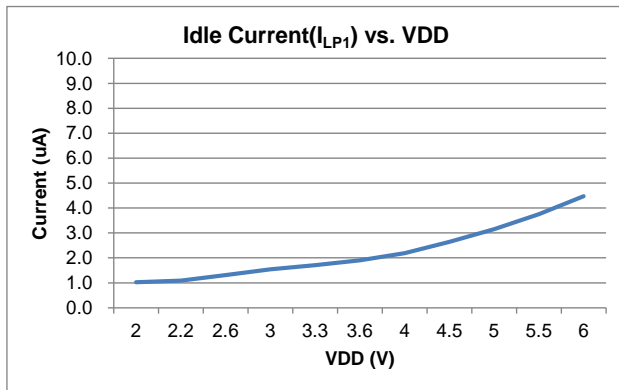

Figure 6.3-5 I_{LP1} vs. VDD

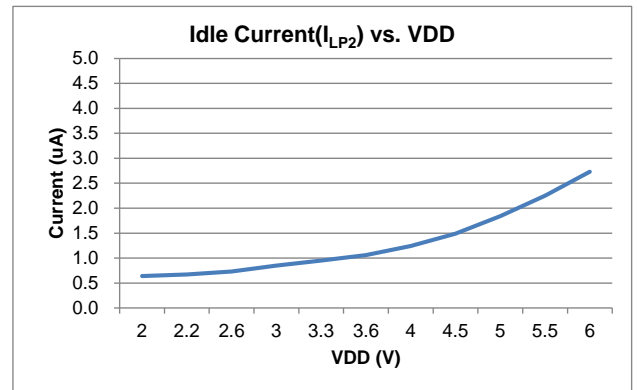

Figure 6.3-6 I_{LP2} vs. VDD

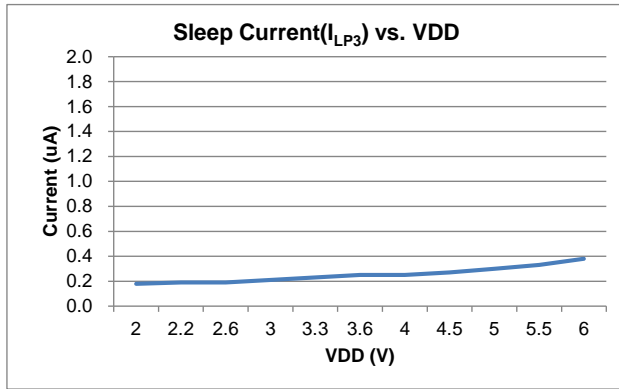

Figure 6.3-7 I_{LP3} vs. VDD

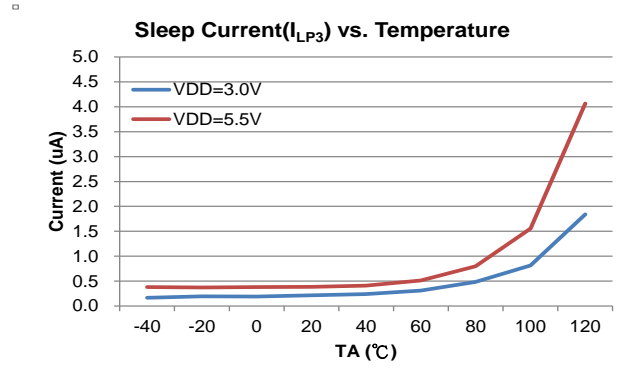

Figure 6.3-8 I_{LP3} vs. Temperature

HY15P41

Embedded 18-Bit ΣΔADC
8-Bit RISC-like Mixed Signal Microcontroller



6.4. Port4

$T_A = 25^\circ\text{C}, V_{DD} = 3.0\text{V}$, unless otherwise noted

Sym.	Parameter	Test Conditions	Min.	Typ.	Max.	unit
Input voltage and Schmitt trigger and leakage current and timing						
V_{IH}	High-Level input voltage		$0.7 \cdot V_{DD}$		V_{DD}	V
V_{IL}	Low-Level input voltage		V_{SS}		$0.3 \cdot V_{DD}$	
V_{hys}	Input Voltage hysteresis($V_{IH} - V_{IL}$)			0.8		V
I_{LKG}	Leakage Current				0.1	μA
R_{PU}	Port pull high resistance			60		$\text{k}\Omega$
R_{PD}	Port pull low resistance	PDR4.x/APDRX0 [1:0]=01		10		$\text{k}\Omega$
		PDR4.x/APDRX0 [1:0]=10		50		$\text{k}\Omega$
		PDR4.x/APDRX0 [1:0]=11		100		$\text{k}\Omega$
Output voltage and current						
V_{OH}	High-level output voltage	$V_{DD} \geq 3\text{V}, I_{OH} = 10\text{mA}$	$V_{DD} - 0.3$			V
		$V_{DD} < 3.0\text{V}, I_{OH} = 10\text{mA}$	$V_{DD} - 0.4$			
		$V_{DD} \geq 4\text{V}, I_{OH} = 15\text{mA}$	$V_{DD} - 0.4$			
V_{OL}	Low-level output voltage	$V_{DD} < 4\text{V}, I_{OL} = -10\text{mA}$			$V_{SS} + 0.3$	V
		$V_{DD} \geq 4\text{V}, I_{OL} = -15\text{mA}$			$V_{SS} + 0.4$	

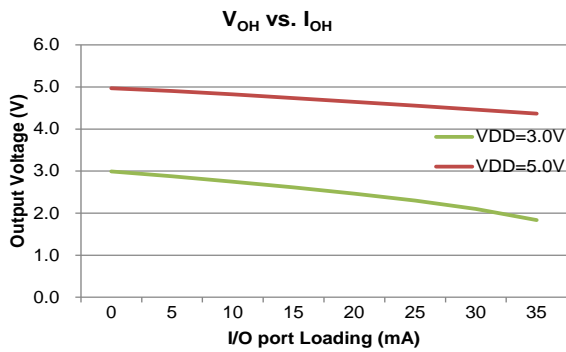

Figure 6.4-1 V_{OH} vs. I_{OH}

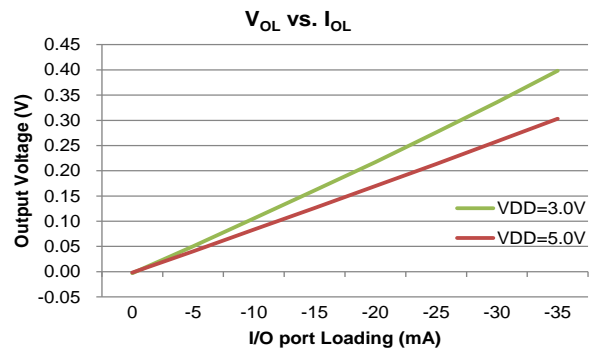

Figure 6.4-2 V_{OL} vs. I_{OL}

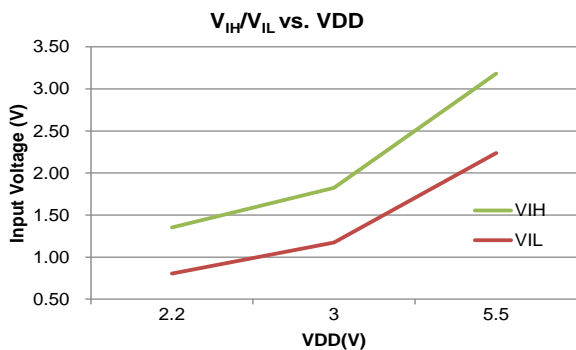

Figure 6.4-3 V_{IH}/V_{IL} vs. V_{DD}

6.5. Rest(Brownout)

$T_A = 25^\circ\text{C}, V_{DD} = 3.0\text{V}$, unless otherwise noted

Sym.	Parameter	Test Conditions	Min.	Typ.	Max.	unit
BOR	Pulse length needed to accepted reset internally, t_{d-LVR}		2			us
	V_{DD} Start Voltage to accepted reset internally (L→H), V_{HYS}		1.6	1.74	2.1	V
	V_{DD} Start Voltage to accepted reset internally (H→L), V_{LVR}		1.6	1.70	2.1	V
	Hysteresis, $V_{HYS-LVR}$		40			mV
BOR : Brownout Reset						

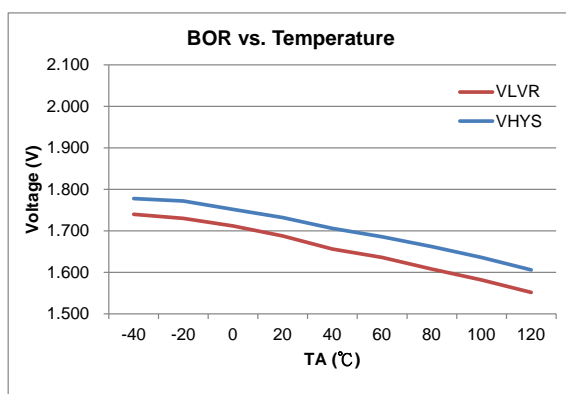

Figure 6.5-1 BOR vs. Temperature

6.6. Power System

$T_A = 25^\circ\text{C}, V_{DD} = 3.0\text{V}$, unless otherwise noted

Sym.	Parameter	Test Conditions		Min.	Typ.	Max.	unit
VDDA	VDDA operation current, I_{VDDA}	$I_L = 0\text{mA}$	LDOC[2:0]=000b	20			μA
	Select VDDA output voltage	$I_L = 0.1\text{mA}$, $V_{DD} \geq V_{VDDA} + 0.25\text{V}$	LDOC [2:0]=000b	2.4		V	
			LDOC [2:0]=001b	2.6			
			LDOC [2:0]=010b	2.9			
			LDOC [2:0]=011b	3.3			
			LDOC [2:0]=100b	3.6			
			LDOC [2:0]=101b	4.0			
	LDOC [2:0]=110b	4.5					
Dropout voltage	$I_L = 10\text{mA}$	LDOC [2:0]=000b	250			mV	
Temperature drift	LDOC [2:0]=000b,	$T_A = -40^\circ\text{C} \sim 85^\circ\text{C}$	50			ppm/ $^\circ\text{C}$	
V_{DD} Voltage drift	$I_L = 0.1\text{mA}$	$V_{DD} = 2.5\text{V} \sim 5.5\text{V}$	± 0.2			%/V	
ACM	ACM operation current, I_{ACM}	ENADC[0]=1b,	ENACM [0]=1b	50			μA
	Internal Analog Common Mode Voltage, $V_{ACM} = V_{VDDA}/2$		$I_L = 0\mu\text{A}$	$V_{VDDA}/2$			V
	Temperature drift	ENADC[0]=1b,	$T_A = -40^\circ\text{C} \sim 85^\circ\text{C}$, ENACM [0]=1b	50			ppm/ $^\circ\text{C}$
V12	V12 operation current, I_{V12}	ENADC[0]=1b,	ENV12 [0]=1b	50			μA
	Internal Analog Common Mode Voltage, V_{12}		$I_L = 0\mu\text{A}$	1.2			V
	Temperature drift	ENADC[0]=1b,	$T_A = -40^\circ\text{C} \sim 85^\circ\text{C}$, ENV12 [0]=1b	50			ppm/ $^\circ\text{C}$

VDDA : Adjust Voltage Regulator
V12 : Internal Analog Common Mode Voltage (No output voltage)
ACM : Internal Analog Common Mode Voltage $V_{VDDA}/2$ (No voltage output)

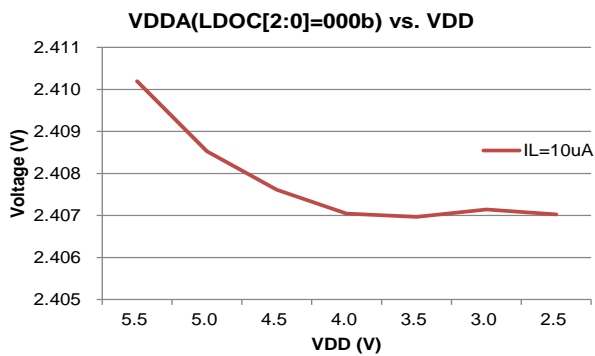

Figure 6.6-1 VDDA(000b) vs. VDD

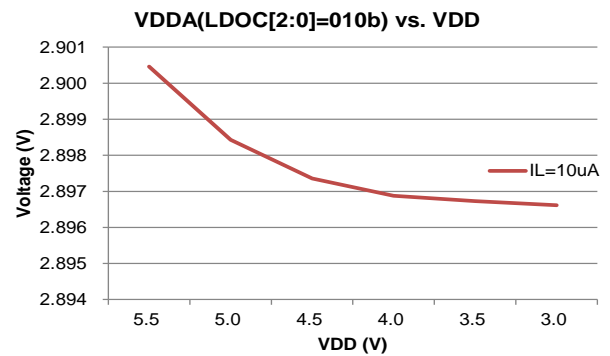

Figure 6.6-2 VDDA(010b) vs. VDD

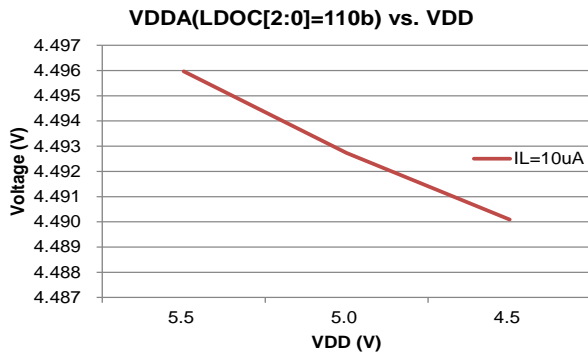

Figure 6.6-3 VDDA(110b) vs. VDD

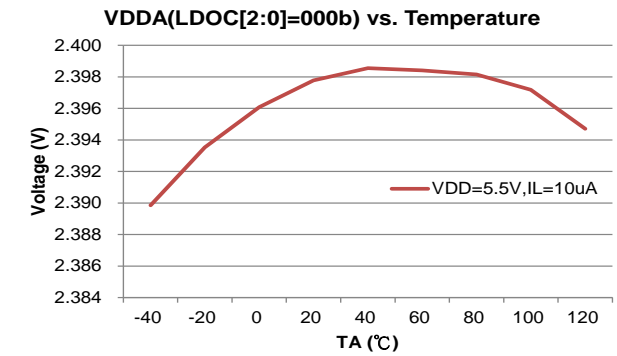

Figure 6.6-4 VDDA(000b) vs. Temperature

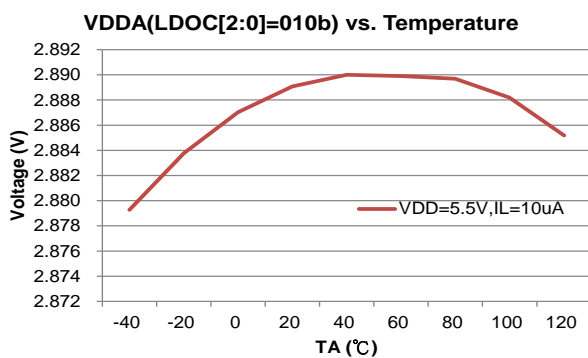

Figure 6.6-5 VDDA(010b) vs. Temperature

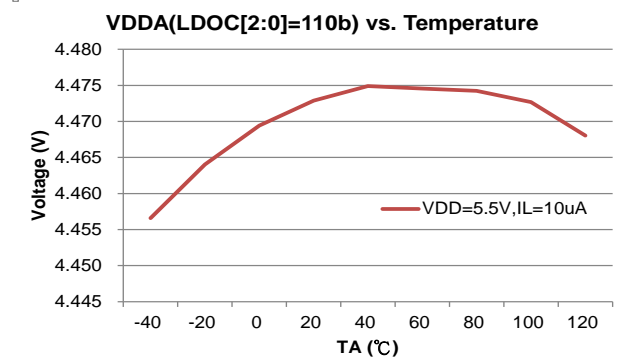

Figure 6.6-6 VDDA(110b) vs. Temperature

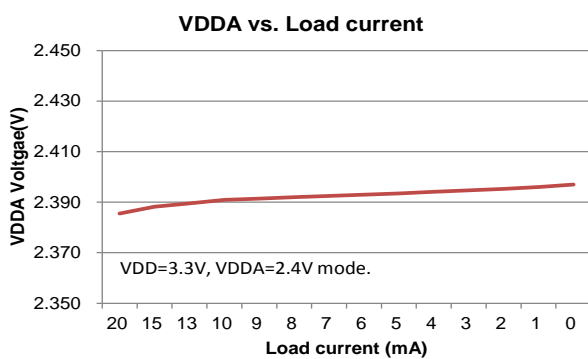

Figure 6.6-7 VDDA vs. Load current

6.7. $\Sigma\Delta$ ADC, Power Supply and recommended operating conditions

$T_A = 25^\circ\text{C}, V_{DD} = 3.0\text{V}, V_{DDA}=2.4\text{V}$, unless otherwise noted

Sym.	Parameter	Test Conditions		Min.	Typ.	Max.	unit
V_{SD18}	Supply Voltage at VDDA	ENVDDA[0]=0		2.4		4.5	V
f_{SD18}	Modulator sample frequency, ADC_CK			125	500		KHz
	Over Sample Ratio, OSR			64		32768	
I_{SD18}	Operation supply current without PGA	ENADC[0]=1	GAIN =1, ADC_CK=500KHz		260		uA

6.7.1. $\Sigma\Delta$ ADC, performance

$T_A = 25^\circ\text{C}, V_{DD} = 3.0\text{V}, V_{DDA}=2.4\text{V}, V_{VR}=1.0\text{V}, \text{GAIN}=1, f_{SD18}=500\text{KHz}$, unless otherwise noted

Sym.	Parameter	Test Conditions		Min.	Typ.	Max.	unit
INL	Integral Nonlinearity(INL)	$V_{DDA}=2.4\text{V}, V_{VR}=1.0\text{V}, \Delta\text{SI}=\pm 450\text{mV}$		± 0.01			%FSR
	No Missing Codes ³	ADC_CK=500KHz, OSR[3:0]=0001b		23			Bits
G_{SD18}	Temperature drift Gain 1~x16		$T_A = -40^\circ\text{C} \sim 85^\circ\text{C}$	10			ppm/ $^\circ\text{C}$
E_{OS}	Offset error of Full Scale Rang input voltage range with Chopper	$\Delta\text{AI}=0\text{V}$ $\Delta\text{VR}=0.9\text{V}$ DCSET[2:0]=<000> * ΔAI is external short	Gain=2	1			%FSR
	Offset temperature drift with chopper		GAIN=1	2			uV/ $^\circ\text{C}$
			GAIN=2	1			
			GAIN=4	0.5			
		GAIN=16	0.15				
CM_{SD18}	Common-mode rejection	$V_{CM}=0.7\text{V}$ to 1.7V, $V_{VR}=1.0\text{V}$	$V_{SI}=0\text{V},$ GAIN=1	90			dB
		$V_{CM}=0.7\text{V}$ to 1.7V, $V_{VR}=1.0\text{V},$	$V_{SI}=0\text{V},$ GAIN=16	75			
PSRR	DC power supply rejection	$V_{DDA}=3.0\text{V}, \Delta V_{DDA}=\pm 100\text{mV},$ $V_{VR}=1.0\text{V}, V_{SI}=V_{SI-}=1.2\text{V},$	GAIN=1	75			dB
			GAIN=16				

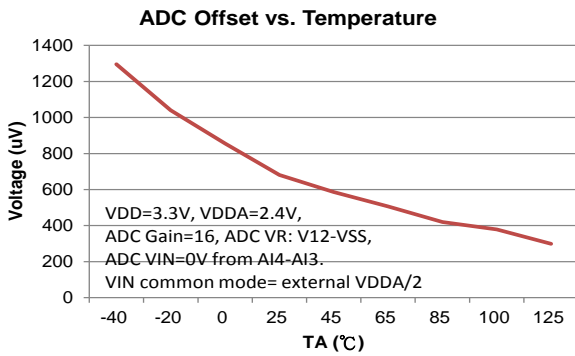

Figure 6.7-1 ADC Offset drift with Temperature

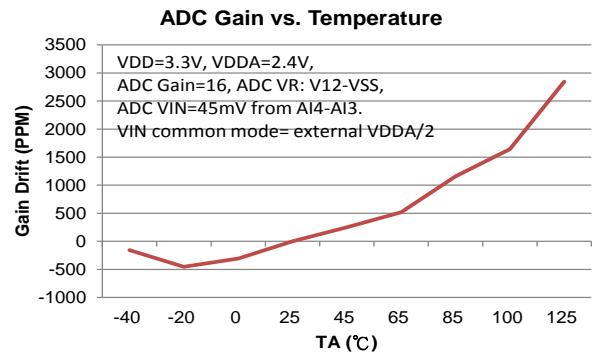

Figure 6.7-2 ADC Gain drift with Temperature

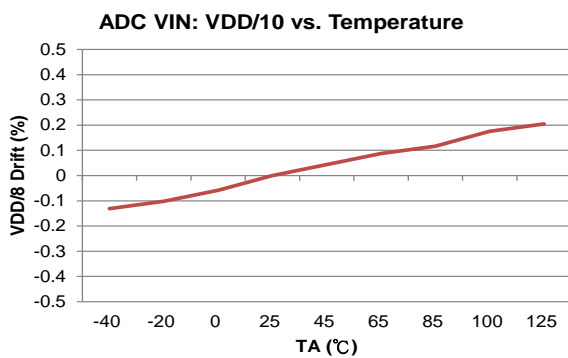

Figure 6.7-3 VDD/10 drift with Temperature

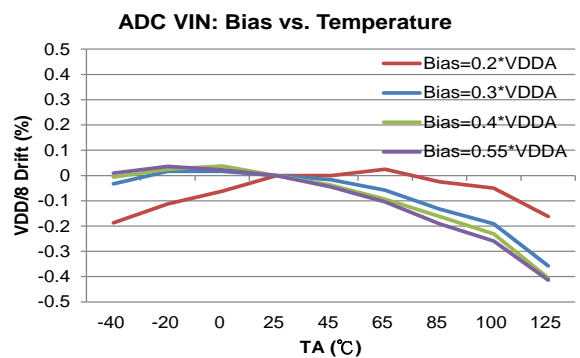

Figure 6.7-4 Bias drift with Temperature

6.7.2. $\Sigma\Delta$ ADC Noise Performance

$T_A = 25^\circ\text{C}$, $V_{DD} = 3.3\text{V}$, $V_{DDA}=2.4\text{V}$, unless otherwise noted

針對 $\Sigma\Delta$ ADC 提供了重要的輸入雜訊規格。Table6.7-2(a), Table6.7-2(b) 列出典型的雜訊規格表與 Gain, Output rate, 及單端最大輸入電壓等關係。測試條件設定在 AI3-AI4 外部輸入訊號短路，ADC 參考電壓源為使用內部 V12 及 VSS 當參考電壓源網路，等效參考電壓為 1.2V，取樣 1024 筆資料。

<i>ENOB(RMS) with OSR/GAIN at A/D Clock=500Khz, VDDA=2.4V, VREF=1.2V</i>												
Max. Vin(mV) =0.9*VREF ⁽¹⁾	OSR		64	128	256	512	1024	2048	4096	8192	16384	32768
	Output rate(HZ)		7813	3906	1953	977	488	244	122	61	31	15
	Gain	ADGN										
±2160	0.25	= 0.25	13.6	15.8	16.2	16.6	17.1	17.6	17.9	18.4	18.7	18.2
±2160	0.5	= 0.5	13.4	15.7	16.3	16.7	17.1	17.6	18.0	18.5	18.6	18.2
±1080	1	= 1	13.7	15.7	16.2	16.7	17.2	17.5	17.9	18.3	18.7	18.5
±540	2	= 2	12.4	15.6	16.1	16.6	17.1	17.6	18.0	18.0	18.0	18.8
±270	4	= 4	12.6	15.5	16.0	16.5	17.0	17.5	17.6	17.7	18.3	18.7
±135	8	= 8	13.5	15.3	15.8	16.3	16.7	17.1	17.4	18.0	18.4	18.4
±68	16	= 16	11.7	15.0	15.5	16.0	16.4	16.8	17.2	17.9	18.4	18.7

(1) Max.Vin (mV) is the max. input voltage of single end to ground (VSS).

Table 6.7-2(a) ADC ENOB Table

<i>RMS Noise(uV) with OSR/GAIN at A/D Clock=500Khz, VDDA=2.4V, VREF=1.2V</i>												
Max. Vin(mV) =0.9*VREF ⁽¹⁾	OSR		64	128	256	512	1024	2048	4096	8192	16384	32768
	Output rate(HZ)		7813	3906	1953	977	488	244	122	61	31	15
	Gain	ADGN										
±2160	0.25	= 0.25	764.77	173.20	130.68	95.36	69.10	47.20	40.37	28.33	22.78	32.07
±2160	0.5	= 0.5	443.87	92.50	61.54	44.77	34.33	24.33	17.85	13.45	12.48	15.83
±1080	1	= 1	181.43	45.93	31.25	23.10	16.54	12.83	9.56	7.24	5.62	6.47
±540	2	= 2	227.93	24.03	16.91	12.11	8.72	6.19	4.66	4.56	4.53	2.65
±270	4	= 4	99.24	13.10	9.27	6.65	4.73	3.35	2.93	2.85	1.86	1.43
±135	8	= 8	25.56	7.30	5.43	3.82	2.80	2.11	1.70	1.14	0.87	0.86
±68	16	= 16	44.04	4.52	3.15	2.33	1.76	1.32	1.03	0.64	0.44	0.36

Table 6.7-2(b) ADC RMS Noise Table

另外針對 $V_{DD}=V_{DDA}=5\text{V}$ 的高壓情況下， $\Sigma\Delta$ ADC 提供了重要的輸入雜訊規格。Table6.7-2(c), Table6.7-2(d) 列出典型的雜訊規格表與 Gain, Output rate, 及單端最大輸入電壓等關係。測試條件設定在 AI3-AI4 外部輸入訊號短路，ADC 參考電壓源為使用內部 $V_{DDA}/2$ 及 VSS 當參考電壓源網路，等效參考電壓為 2.5V，取樣 1024 筆資料。

<i>ENOB(RMS) with OSR/GAIN at VDD=VDDA=5.0V, A/D Clock=500Khz, VR=VDDA/2-VSS</i>											
Max. Vin(mV) =0.9*VREF ⁽¹⁾	OSR	64	128	256	512	1024	2048	4096	8192	16384	32768
	Output rate(HZ)	7813	3906	1953	977	488	244	122	61	31	15
	GAIN										
±9000	1/4	14.4	15.6	16.1	16.7	17.0	17.6	18.0	18.6	19.1	19.5
±4500	1/2	14.1	15.8	16.3	16.9	17.4	17.8	18.2	18.7	19.3	19.7
±2250	1	13.8	15.7	16.2	16.7	17.1	17.7	18.1	18.5	19.0	19.5
±1125	2	14.4	15.6	16.4	16.8	17.3	17.9	18.2	18.7	19.2	19.6
±562.5	4	13.0	15.6	16.3	16.7	17.1	17.7	18.1	18.6	19.1	19.5
±281.25	8	14.5	15.5	16.1	16.6	17.1	17.5	17.9	18.4	18.8	19.3
±140.625	16	11.7	15.5	16.1	16.6	17.0	17.3	17.6	18.4	18.8	19.3

Table 6.7-2(c) ADC ENOB Table

<i>RMS Noise(μV) with OSR/GAIN at VDD=VDDA=5.0V, A/D Clock=500Khz, VR=VDDA/2-VSS</i>											
Max. Vin(mV) =0.9*VREF (1)	OSR	64	128	256	512	1024	2048	4096	8192	16384	32768
	Output rate(HZ)	7813	3906	1953	977	488	244	122	61	31	15
	GAIN										
± 9000	1/4	960.2	407.4	278.9	192.6	148.2	99.9	76.4	51.9	36.4	27.5
± 4500	1/2	590.3	178.7	124.1	80.1	58.8	44.4	34.2	24.3	15.7	12.1
± 2250	1	344.9	93.0	64.5	48.0	35.0	24.1	17.5	13.8	9.8	6.8
± 1125	2	118.9	49.2	29.8	22.5	15.8	10.2	8.5	5.7	4.1	3.2
± 562.5	4	155.7	25.5	15.8	11.8	8.9	5.8	4.5	3.1	2.3	1.6
± 281.25	8	26.8	13.2	8.8	6.5	4.4	3.3	2.5	1.8	1.3	1.0
± 140.625	16	97.0	6.7	4.6	3.3	2.5	1.9	1.5	0.9	0.7	0.5

Table 6.7-2(d) ADC RMS Noise Table

The RMS noise are referred to the input. The Effective Number of Bits (ENOB(RMS Bit)) is defined as:

$$\text{ENOB(RMS)} = \frac{\ln\left(\frac{\text{FSR}}{\text{RMS Noise}}\right)}{\ln(2)}$$

$$\text{RMS Noise} = \frac{\left(2 \times \text{VREF} \times \sqrt{\sum_{k=1}^{1024} (\text{ADO}[k] - \text{Average})^2}\right)}{2^{23}}$$

Where FSR (Full - Scale Range) = $2 \times \text{VREF}/\text{Gain}$.

$$\text{Average} = \frac{\sum_{k=1}^{1024} (\text{ADO}[k])}{1024}$$

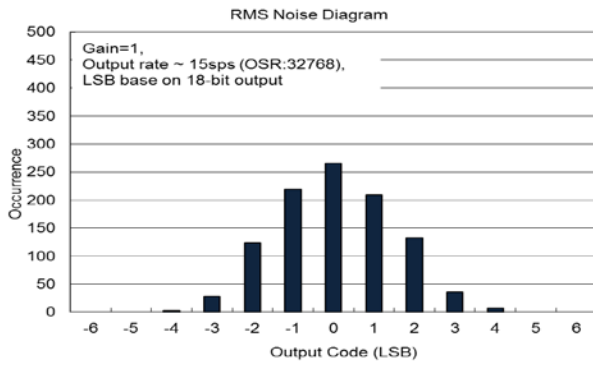

Figure 6.7-5 RMS Noise Diagram

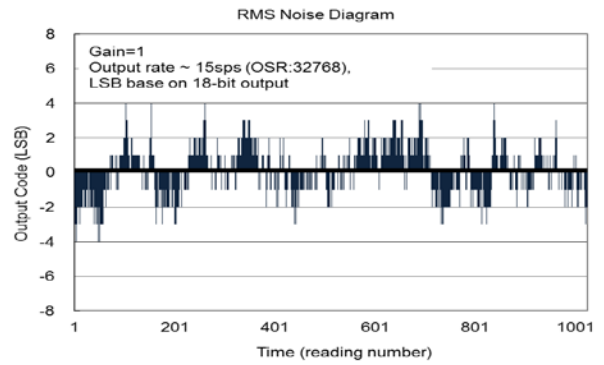

Figure 6.7-6 Output Code Diagram

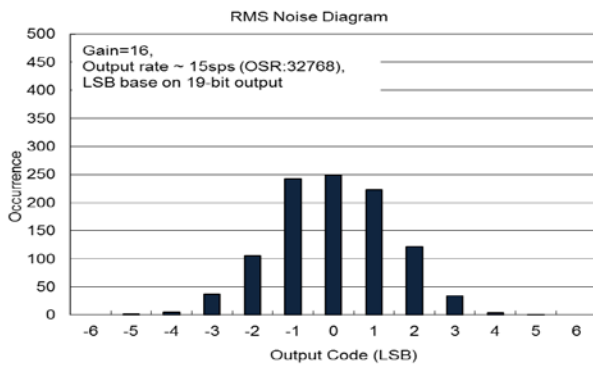

Figure 6.7-7 RMS Noise Diagram

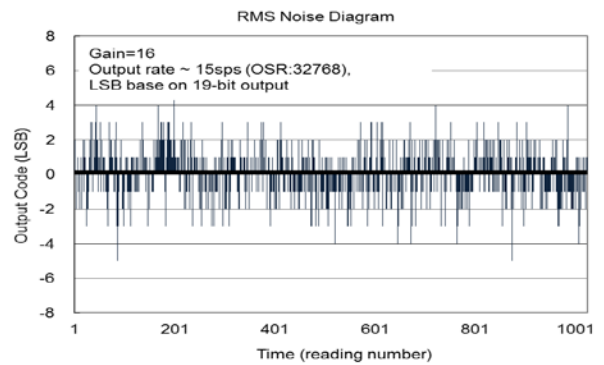

Figure 6.7-8 Output Code Diagram

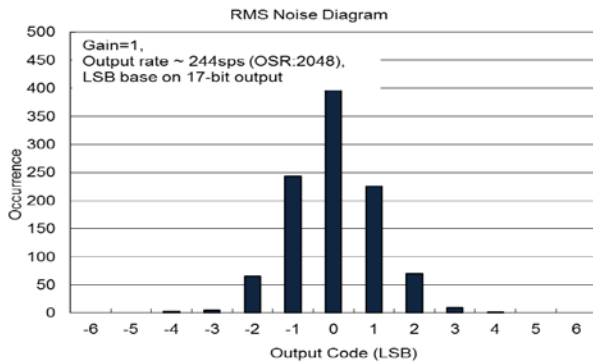

Figure 6.7-9 RMS Noise Diagram

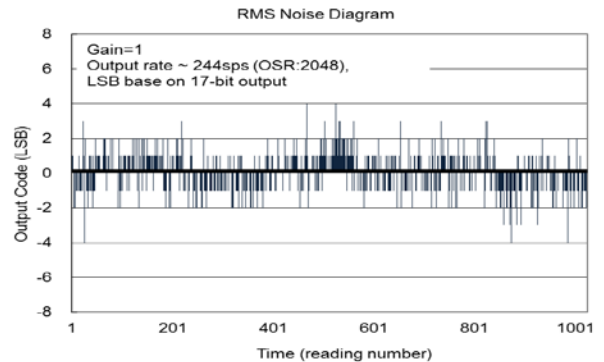

Figure 6.7-10 Output Code Diagram

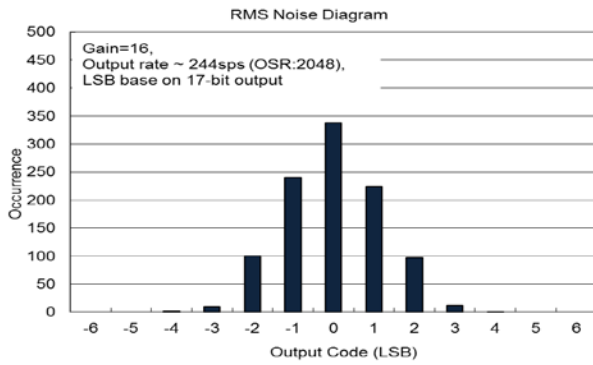

Figure 6.7-11 RMS Noise Diagram

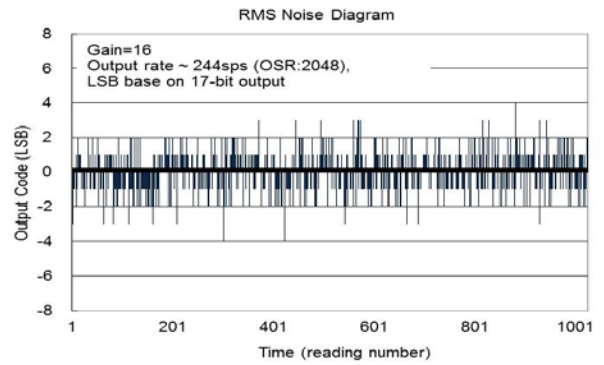

Figure 6.7-12 Output Code Diagram

6.7.3. $\Sigma \Delta$ ADC, Temperature Sensor

$T_A = 25^\circ\text{C}, V_{DD} = 3.0\text{V}, V_{DDA} = 2.4\text{V}$, unless otherwise noted

Sym.	Parameter	Test Conditions	Min.	Typ.	Max.	unit
TC _S	Sensor temperature drift			173		uV/°C
KT	Absolute Temperature Scale 0°K			-284		°C
TC _{ERR}	One point calibrate error temperature	Calibration at 25°C of -40°C ~85°C		±2		°C

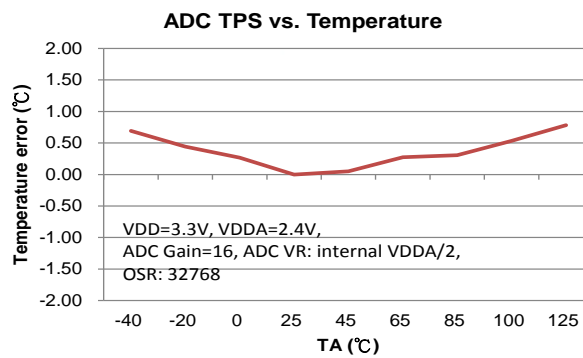

Figure 6.7-13 ADC Temperature Error

6.8. Build-In EPROM(BIE)

$T_A = 25^\circ\text{C}, V_{DD} = 3.0\text{V}$, unless otherwise noted

Sym.	Parameter	Test Conditions	Min.	Typ.	Max.	unit
T_O	Operation temperature range		0	25	40	$^\circ\text{C}$
V_{DD}	Operation supply Voltage		2.75		5.5	V
V_{BIE}	Supply Voltage			8.5	8.75	V
I_{BIE}	Operation supply current			5		mA
V_{SS}	Supply Voltage			0		V

When connecting to the external V_{BIE} power source to program the BIE block, users can use the instruction to program the words one by one into the BIE block.

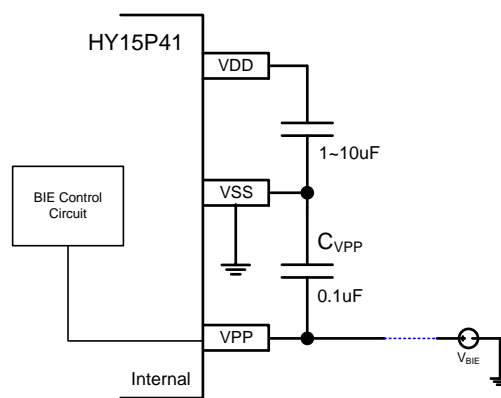

Figure 6-8 BIE typical application 方塊圖

7. 訂貨資訊

下單品名 ¹	封裝型式	引腳數	封裝型式		程式碼 編號 ²	出貨包裝形式	個裝數量	材料組成	MSL ³
			A	S					
HY15P41-AS12	DFN	12	A	S12	000	Tape & Reel	500	Green ⁴	MSL-3
HY15P41-S016	SOP	16	S	016	000	Tube	50	Green ⁴	MSL-3
HY15P41-S016	SOP	16	S	016	000	Tape & Reel	2500	Green ⁴	MSL-3
HY15P41-S008	SOP	8	S	008	000	Tube	100	Green ⁴	MSL-3
HY15P41-S008	SOP	8	S	008	000	Tape & Reel	2500	Green ⁴	MSL-3

¹ 產品名稱 – 封裝型式描述方式 – 程式碼編號 (空白片 / 標準品 / 代客燒錄碼)

例如：您的代客燒錄服務申請的程式碼編號為 007，且需要的產品是 SOP16 出貨。
則下單品名為 HY15P41-S016-007

例如：您的需求是不帶程式碼的空白片且需要的產品是 SOP16 出貨。則下單品名為 HY15P41-S016

例如：您的代客燒錄服務申請的程式碼編號為 008，而需求的產品是封裝片 SOP8 出貨，則下單品名為 HY15P41-S008-008，且需以 Tape & Reel 出貨，則除下單品名外，請特別註明出貨包裝形式為 Tape & Reel

² 程式碼編號

“001”~“999” 為標準品或代客燒錄申請的程式碼編號，而空白晶片不帶此碼。

³ MSL:

濕度敏感性等級係依據 IPC/JEDEC J-STD-020 的規範加以試驗分級，並參考 IPC/JEDEC J-STD-033 的標準處理、包裝、運輸與使用。

⁴ Green (RoHS & no Cl/Br):

HYCON 產品皆為 Green Product，符合 RoHS 指令以及無鹵素規定(Br<900ppm or Cl<900ppm or (Br+Cl)<1500ppm)

HY15P41

Embedded 18-Bit $\Sigma\Delta$ ADC
8-Bit RISC-like Mixed Signal Microcontroller

8. 封裝型式資訊

8.1. SOP8(S008)

8.1.1. Package Dimensions

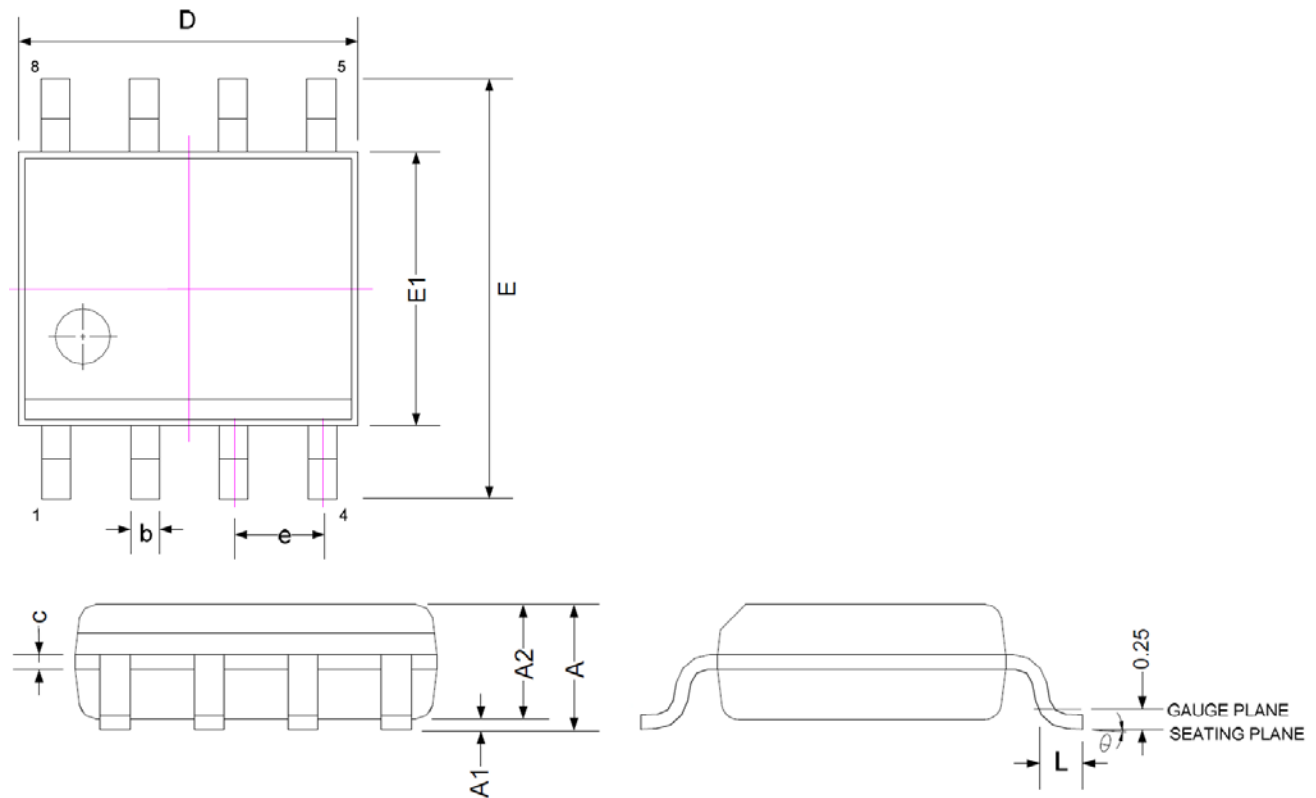

SYMBOLS	MIN	NOM	MAX
A	-	-	1.75
A1	0.10	-	0.25
A2	1.25	-	-
b	0.31	-	0.51
c	0.10	-	0.25
D	4.90 BSC		
E1	3.90 BSC		
E	6.00 BSC		
L	0.40	-	1.27
e	1.27 BSC		
θ°	0	-	8

Note:

1. All dimensions refer to JEDEC OUTLINE MS-012.
2. Do not include Mold Flash or Protrusions.
3. Unit: mm.

HY15P41

Embedded 18-Bit $\Sigma\Delta$ ADC
8-Bit RISC-like Mixed Signal Microcontroller

8.1.3. Tape & Reel Information

8.1.3.1. Reel Dimensions –Type1

Unit : mm

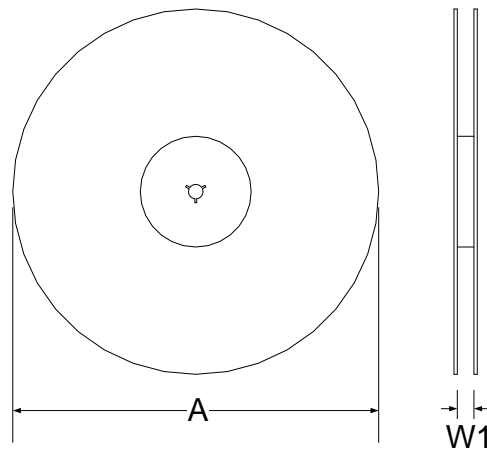

8.1.3.2. Carrier Tape Dimensions

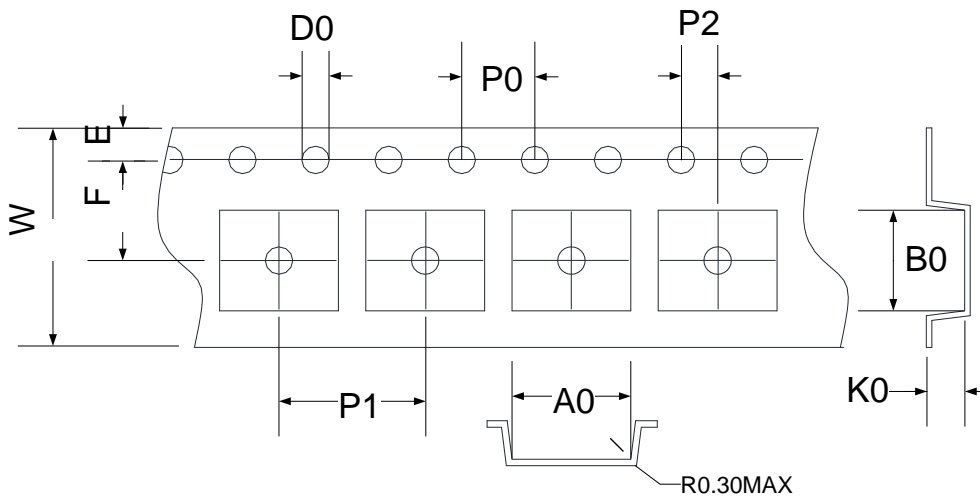

SYMBOLS	Reel Dimensions		Carrier Tape Dimensions										
	A	W1	A0	B0	K0	P0	P1	P2	E	F	D0	W	
Spec.	330	12.5	6.90	5.40	2.00	4.00	8.00	2.00	1.75	5.50	1.50	12.00	
Tolerance	+6/-3	+1.5/-0	±0.10	±0.10	±0.10	±0.10	±0.10	±0.10	±0.05	±0.10	±0.05	+0.1/-0	±0.30

Note: 10 Sprocket hole pitch cumulative tolerance is ± 0.20 mm.

Unit : mm

8.1.3.3. Pin1 direction

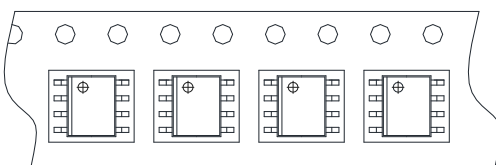

HY15P41

Embedded 18-Bit $\Sigma\Delta$ ADC
8-Bit RISC-like Mixed Signal Microcontroller



8.1.3.4. Reel Dimensions –Type2

Unit : mm

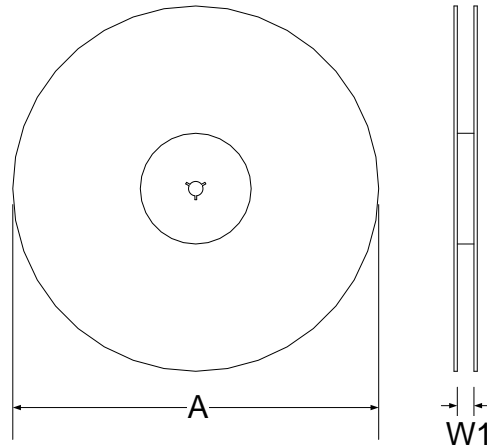

8.1.3.5. Carrier Tape Dimensions

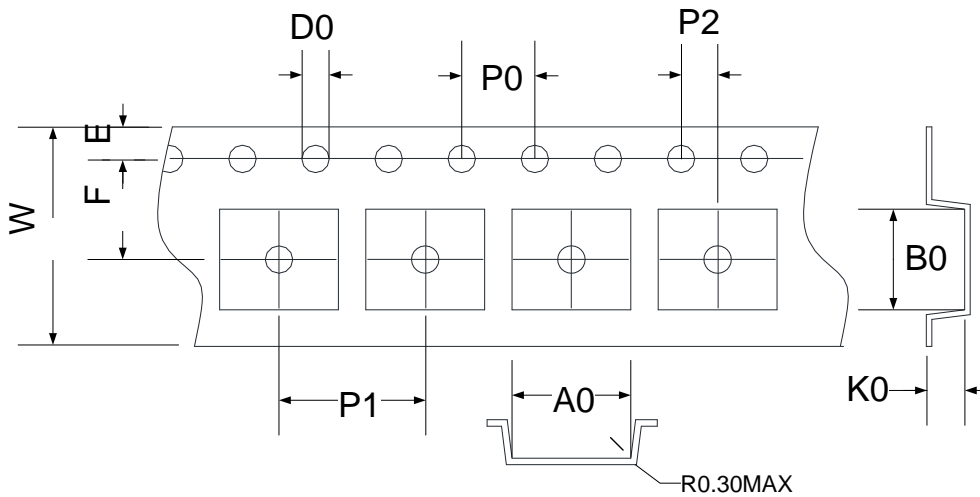

SYMBOLS	Reel Dimensions		Carrier Tape Dimensions										
	A	W1	A0	B0	K0	P0	P1	P2	E	F	D0	W	
Spec.	330	12.5	6.50	5.20	2.10	4.00	8.00	2.00	1.75	5.50	1.50	12.00	
Tolerance	+6/-3	+1.5/-0	±0.10	±0.10	±0.10	±0.10	±0.10	±0.10	±0.05	±0.10	±0.05	+0.1/-0	±0.30

Note: 10 Sprocket hole pitch cumulative tolerance is ± 0.20 mm.

Unit : mm

8.1.3.6. Pin1 direction

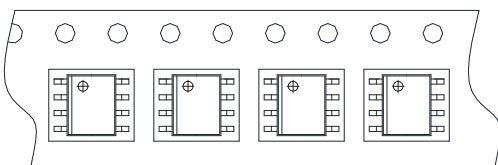

HY15P41

Embedded 18-Bit $\Sigma\Delta$ ADC
8-Bit RISC-like Mixed Signal Microcontroller

8.2. SOP16(S016)

8.2.1. Package Dimensions

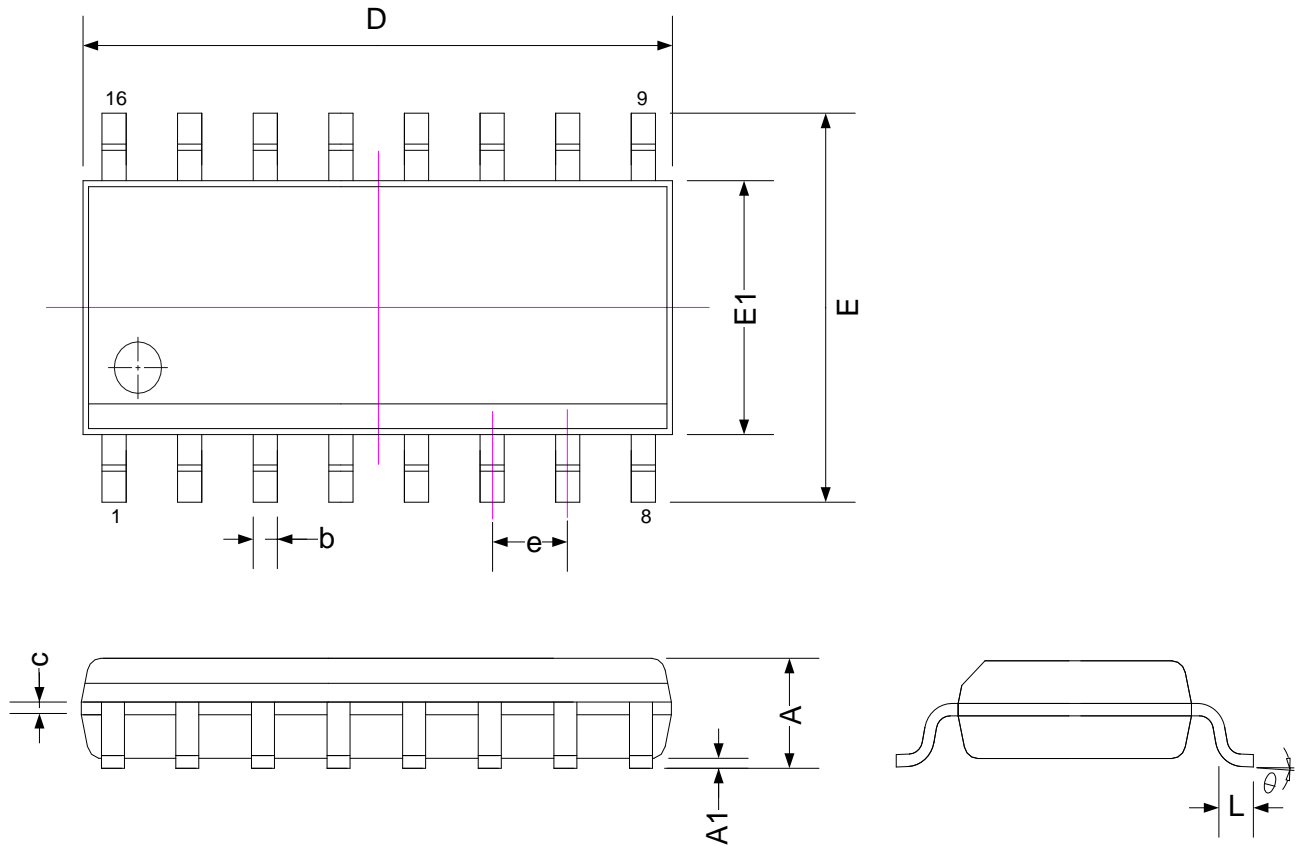

SYMBOLS	MIN	NOM	MAX
A	-	-	1.75
A1	0.10	-	0.25
b	0.31	-	0.51
c	0.10	-	0.25
D	9.90 BASIC		
E1	3.90 BASIC		
E	6.00 BASIC		
L	0.40	-	1.27
e	1.27 BASIC		
θ	0	-	8

Note :

1. All dimensions refer to JEDEC OUTLINE MS-012.
2. Do not include Mold Flash or Protrusions.
3. Unit: mm.

HY15P41

Embedded 18-Bit $\Sigma\Delta$ ADC
8-Bit RISC-like Mixed Signal Microcontroller

8.2.3. Tape & Reel Information

8.2.3.1. Reel Dimensions –Type1

Unit : mm

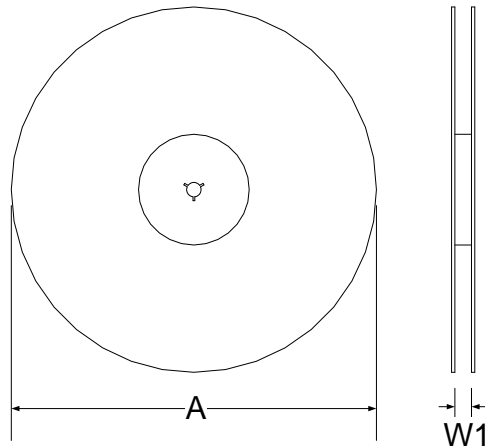

8.2.3.2. Carrier Tape Dimensions

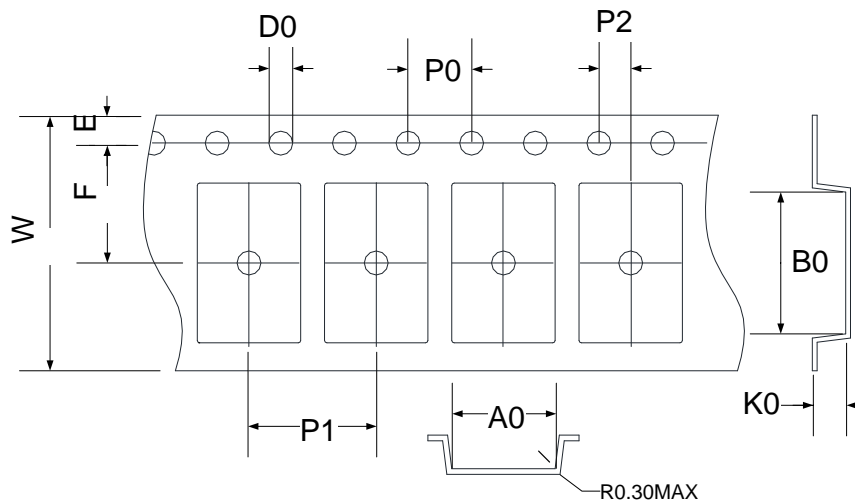

SYMBOLS	Reel Dimensions		Carrier Tape Dimensions									
	A	W1	A0	B0	K0	P0	P1	P2	E	F	D0	W
Spec.	330	16.5	6.50	10.30	2.10	4.00	8.00	2.00	1.75	7.50	1.50	16.00
Tolerance	+6/-3	+1.5/-0	±0.10	±0.10	±0.10	±0.10	±0.10	±0.05	±0.10	±0.10	+0.1/-0	±0.30

8.2.3.3. Pin1 direction

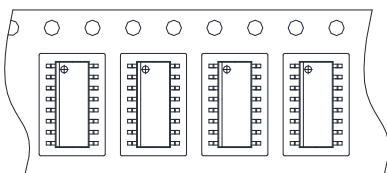

8.3. DFN12(AS12)

8.3.1. Package Dimensions

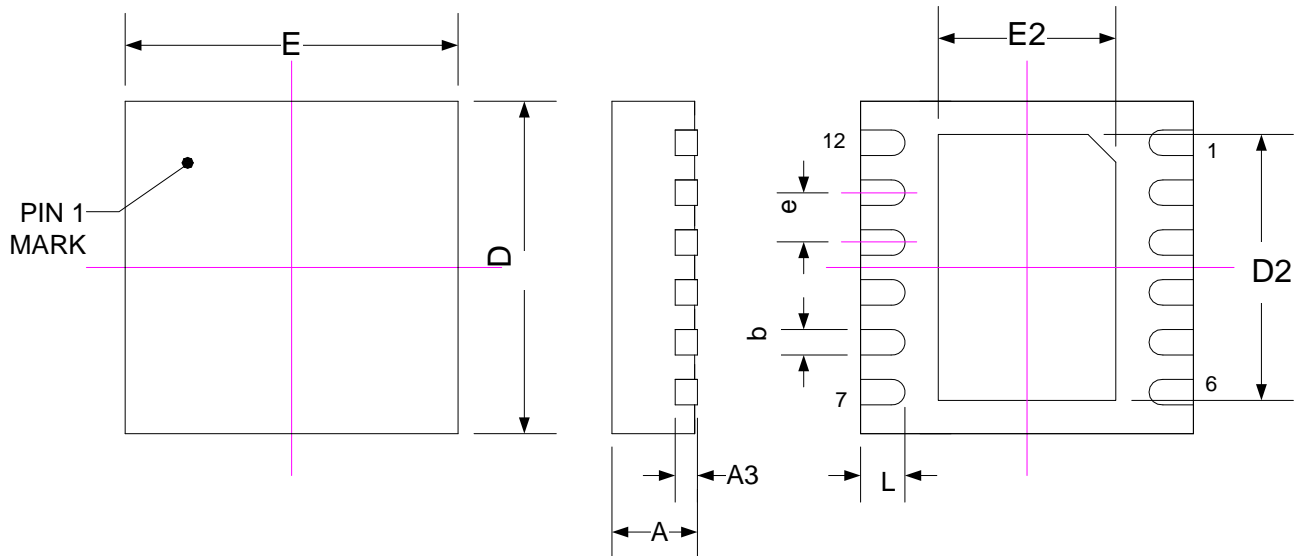

SYMBOLS	MIN	NOM	MAX
A	0.70	0.75	0.80
A3	0.20 REF.		
b	0.18	0.24	0.28
D	2.90	3.00	3.10
E	2.90	3.00	3.10
D2	2.25	2.40	2.55
E2	1.50	1.65	1.75
L	0.30	0.40	0.50
e	0.45 BSC		

Note :

1. All dimensions refer to JEDEC OUTLINE MS-012.
2. Do not include Mold Flash or Protrusions.
3. Unit: mm.

HY15P41

Embedded 18-Bit $\Sigma\Delta$ ADC
8-Bit RISC-like Mixed Signal Microcontroller



8.3.2. Tape & Reel Information

8.3.2.1. Reel Dimensions –Type1

Unit : mm

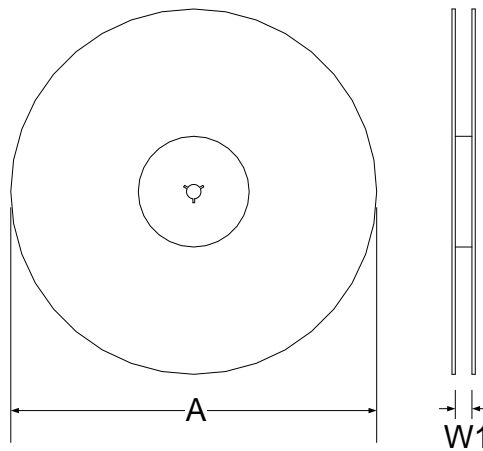

8.3.2.2. Carrier Tape Dimensions

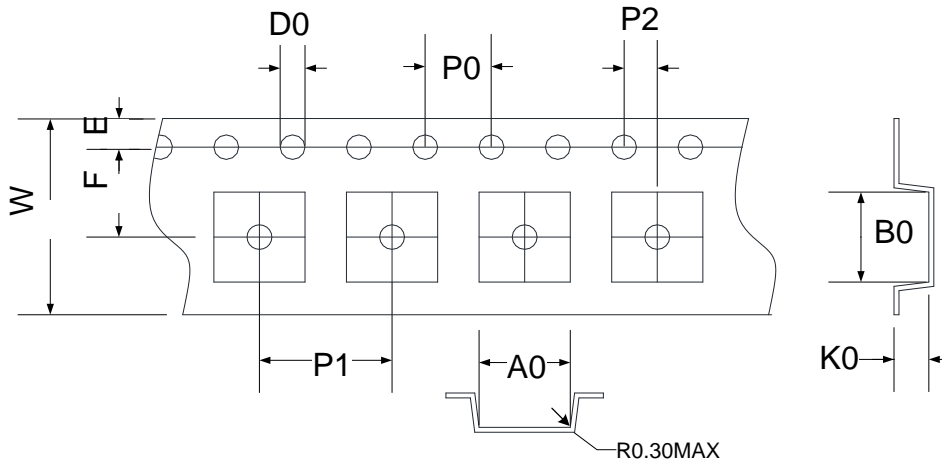

SYMBOLS	Reel Dimensions		Carrier Tape Dimensions									
	A	W1	A0	B0	K0	P0	P1	P2	E	F	D0	W
Spec.	330	12.5	3.30	3.30	1.10	4.00	8.00	2.00	1.75	5.50	1.50	12.00
Tolerance	+6/-3	+1.5/-0	±0.10	±0.10	±0.10	±0.10	±0.10	±0.10	±0.05	±0.10	±0.05	+0.1/-0 ±0.30

Note: 10 Sprocket hole pitch cumulative tolerance is ± 0.20 mm.

8.3.2.3. Pin1 direction

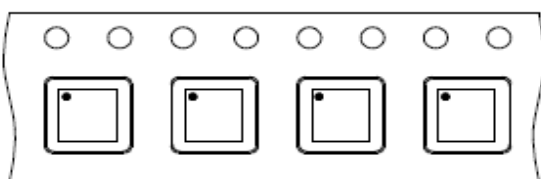

9. 修訂記錄

以下描述本文件差異較大的地方，而標點符號與字形的改變不在此描述範圍。

版本	頁次	變更摘要
V01	All	初版發行
V02	11	更新應用電路圖
	20~21	更新暫存器列表
V03	20~21	更新暫存器列表
	22~35	更新電氣規格與增加圖表說明
V04	15	更新 ADC 網路通道
	27	更新 BOR 規格與曲線
V05	5	新增功能列表
	All	更新 SOP8 引腳定義
	All	刪除 SSOP16 封裝訊息，新增 SOP16 封裝訊息
V06	13	更新 CLK 方塊圖
	34	新增 VDD=5V 情況下，ENOB Table
V07	12	新增 DFN12 引腳定義
	41~50	刪除 Die 販售訊息，新增 DFN12 封裝需訊息