



HY15P43
Datasheet
8-Bit RISC-like Mixed Signal Microcontroller
Embedded 8x8 LED Driver
18-Bit Σ ADC

Table of Contents

1. 特點	5
2. 引腳定義	6
2.1. LQFP 7x7 48L引腳圖	6
2.2. TSSOP28 引腳圖	7
2.3. I/O定義與說明	8
2.4. 封裝片標記信息	11
3. 應用電路	12
4. 功能概述	13
4.1. 內部方塊圖	13
4.2. 相關說明與支援文件	13
4.3. Clock System	14
4.4. Low Voltage Detect(LVD)	15
4.5. Reset	16
4.6. Power System	16
4.7. SD18 Network	17
4.8. GPIO	17
4.9. Watch Dog	17
4.10. 8-bit Timer A	18
4.11. 16-bit Timer B	19
4.12. LED	20
4.13. EUART	20
4.14. SPI	21

HY15P43

Embedded 18-Bit Σ ADC

8-Bit RISC-like Mixed Signal Microcontroller



4.15.	I2C.....	22
5.	暫存器列表.....	23
6.	電氣特性	25
6.1.	Recommended operating conditions	25
6.2.	Internal RC Oscillator	25
6.3.	Supply current into VDD excluding peripherals current	26
6.4.	Port 1~2, 6~7	26
6.5.	Reset(Brownout, Low Voltage Detect)	27
6.6.	Power System	28
6.7.	SD18, Power Supply and recommended operating conditions	29
6.8.	Build-In EPROM(BIE).....	32
6.9.	Build-In EPROM(BIE) Low voltage control circuit.....	32
7.	訂貨資訊	33
8.	封裝型式資訊.....	34
8.1.	LQFP 7x7 48L(L048).....	34
8.2.	TSSOP28(T028)	35
9.	附錄A.....	38
9.1.	HY15P系列產品差異比較表	38
10.	修訂記錄	39

HY15P43

Embedded 18-Bit $\Sigma\Delta$ ADC

8-Bit RISC-like Mixed Signal Microcontroller

注意：

- 1、本說明書中的內容，隨著產品的改進，有可能不經過預告而更改。請客戶及時到本公司網站下載更新 <http://www.hycontek.com>。
- 2、本規格書中的圖形、應用電路等，因第三方工業所有權引發的問題，本公司不承擔其責任。
- 3、本產品在單獨應用的情況下，本公司保證它的性能、典型應用和功能符合說明書中的條件。當使用在客戶的產品或設備中，以上條件我們不作保證，建議客戶做充分的評估和測試。
- 4、請注意輸入電壓、輸出電壓、負載電流的使用條件，使 IC 內的功耗不超過封裝的容許功耗。對於客戶在超出說明書中規定額定值使用產品，即使是瞬間的使用，由此所造成的損失，本公司不承擔任何責任。
- 5、本產品雖內置防靜電保護電路，但請不要施加超過保護電路性能的過大靜電。
- 6、本規格書中的產品，未經書面許可，不可使用在要求高可靠性的電路中。例如健康醫療器械、防災器械、車輛器械、車載器械及航空器械等對人體產生影響的器械或裝置，不得作為其部件使用。
- 7、本公司一直致力於提高產品的品質和可靠度，但所有的半導體產品都有一定的失效概率，這些失效概率可能會導致一些人身事故、火災事故等。當設計產品時，請充分留意冗餘設計並採用安全指標，這樣可以避免事故的發生。
- 8、本規格書中內容，未經本公司許可，嚴禁用於其他目的之轉載或複製。

1. 特點

- 8 位元 H08A 加強型精簡指令集，共有 66 個指令包含硬體乘法指令及查表指令
- 2.2V to 5.5V 工作電壓範圍，-40~85°C 工作溫度範圍。
- 支援外部石英震盪器 1MHZ~4MHZ/32768HZ 及內部高精度 RC 震盪器 2MHZ/4MHZ，多種 CPU 工作時脈切換選擇，可讓使用者達到最佳省電規劃
 - 運行模式
 - 待機模式
 - 休眠模式
- 5KWord OTP Type 程式記憶體，128Byte 資料記憶體
- Brownout detector 及 Watch dog Timer，可防止 CPU 進入死機模式。
- 8 個七段顯示驅動器
 - 支援 LED 顯示控制寄存器
 - 共陰極或是共陽極驅動支援
 - 單一位元設定可以閃爍字節顯示
 - 12 個 LED 埠可設定為數位輸出埠
 - 支援 Non-Overlap 掃描方式
- 18bit 全差動輸入 $\Sigma\Delta$ ADC 類比數位轉換器
 - 內置 PGA (Programmable Gain Amplifier) 可有 128 倍輸入信號放大倍率選擇
 - 內置輸入零點調整，可針對不同應用增加其量測範圍
 - 可選擇不同的數據輸出速率，最高可達 15.6ksps
 - 內置絕對溫度感測器
- LVD 低電壓檢測功能具 14 段檢測電壓設置與外部輸入電壓檢測功能
- 類比電壓源 VDDA 具 10mA 穩壓電壓源輸出能力，快速啟動功能，可提供傳感器驅動電壓
- 8-bit Timer A
- 16-bit Timer B 模組具 Compare/PWM 功能
- 串列通訊 EUART，SPI，I2C 模組
- Built-In EPROM (BIE)，內建 2.75V 低壓燒錄控制電路
- Support 6 stack level.

HY15P43

Embedded 18-Bit $\Sigma\Delta$ ADC

8-Bit RISC-like Mixed Signal Microcontroller

2. 引腳定義

2.1. LQFP 7x7 48L 引腳圖



圖 2-1 HY15P43 LQFP 7x7 48L 引腳圖

2.2. TSSOP28 引腳圖

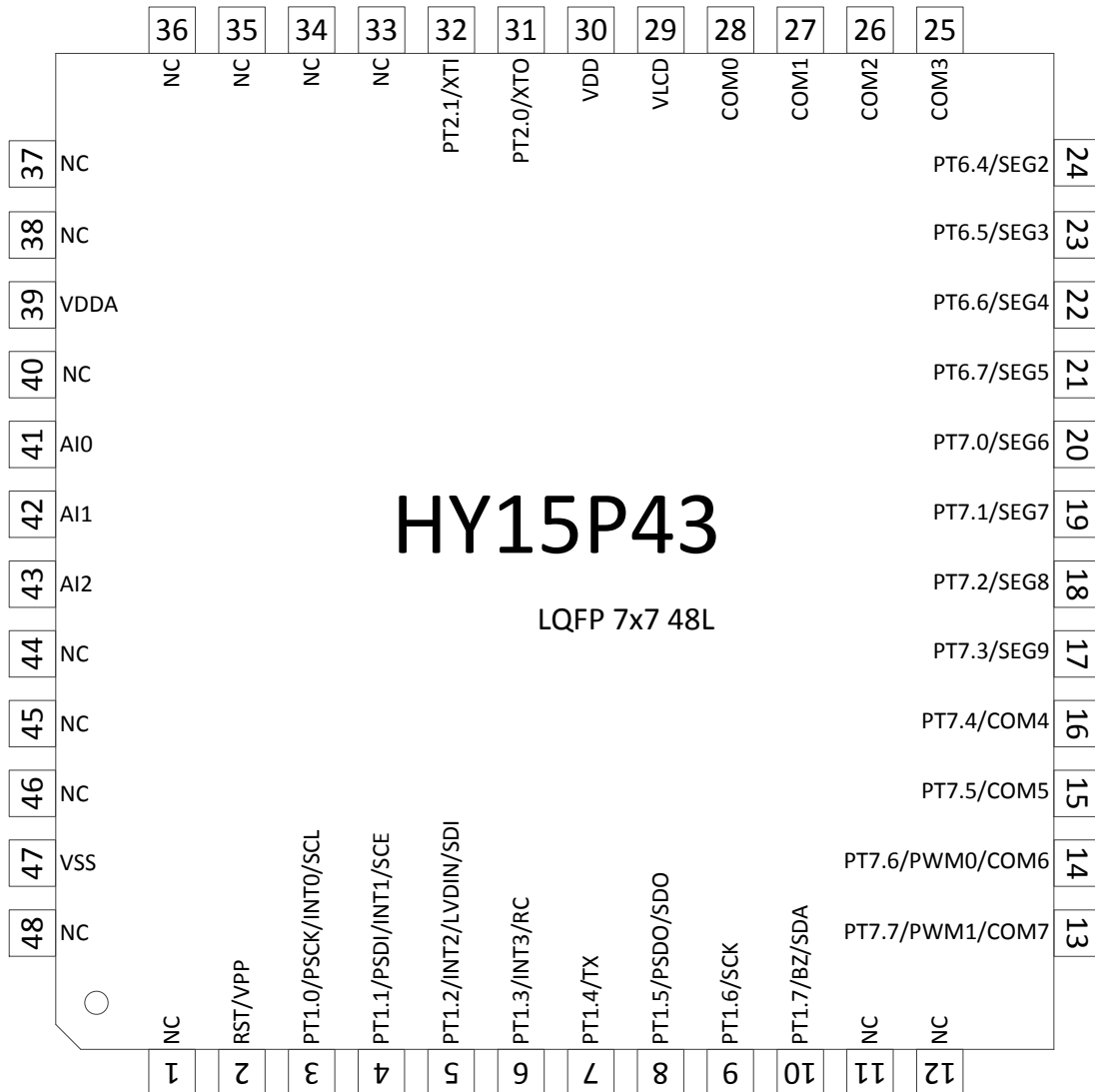

圖 2-2 HY15P43 TSSOP28 引腳圖

註 1：VPP與RST復用同一接口，非燒錄OTP時禁止輸入高電壓

2.3. I/O 定義與說明

“I/O”輸入/輸出,“I”輸入,“O”輸出,“S”史密斯觸發,“C”CMOS 特性兼容輸出與輸入,“P”電壓源,“A”類比通道

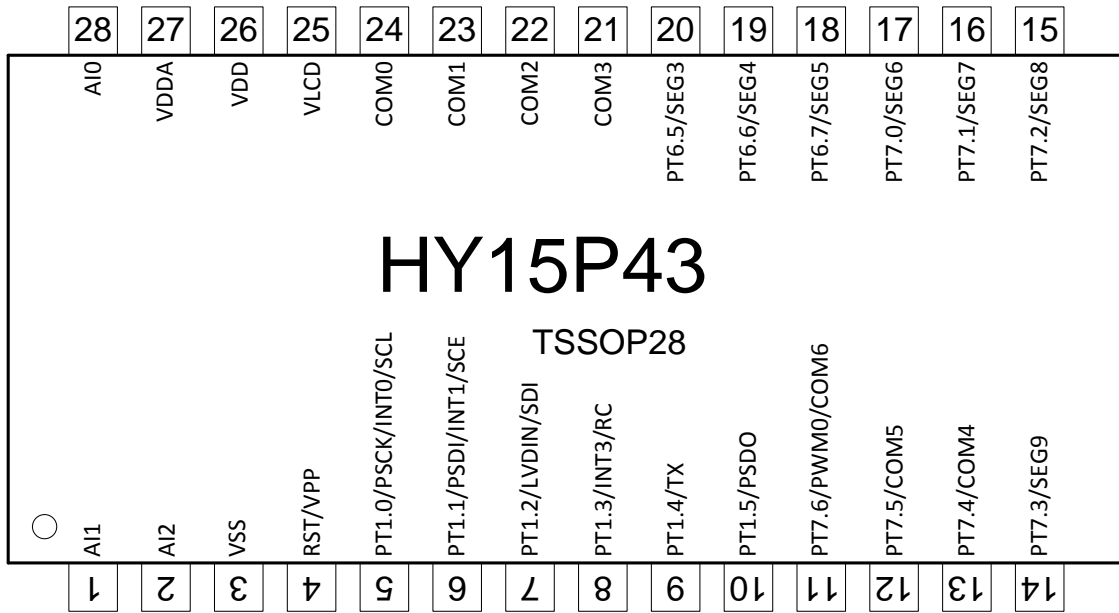
LQFP48 引腳編號	TSSOP28 引腳編號	引腳名稱	引腳特性		功能說明	
			格式	緩衝		
2	4	RST/VPP	RST	I	S	復位晶片
			VPP	P	P	OTP讀/寫時的電壓源
3	5	PT1.0/INT0/PSCK/SCL	PT1.0	I/O	S	數位輸入/輸出
			INT0	I	S	中斷源INT0
			PSCK	I	S	OTP讀/寫介面接口
			SCL	I/O	S	I2C 通訊介面引腳
4	6	PT1.1/INT1/PSDI/SCE	PT1.1	I/O	S	數位輸入/輸出
			INT1	I	S	中斷源INT1
			PSDI	I	S	OTP讀/寫介面接口
			SCE	I/O	S	SPI 通訊介面接口
5	7	PT1.2/INT2/LVDIN/SDI	PT1.2	I/O	S	數位輸入
			INT2	I	S	中斷源INT2
			LVDIN	A	A	LVD外部信號輸入接口
			SDI	I/O	S	SPI通訊介面接口
6	8	PT1.3/INT3/RC	PT1.3	I/O	S	數位輸入
			INT3	I	S	中斷源INT3
			RC	I	S	EUART通訊介面接口
7	9	PT1.4/TX	PT1.4	I/O	S	數位輸入/輸出
			TX	O	S	EUART通訊介面接口
8	10	PT1.5/PSDO/SDO	PT1.5	I/O	S	數位輸入/輸出
			PSDO	O	C	OTP讀/寫介面接口
			SDO	I/O	S	SPI 通訊介面接口
9	-	PT1.6/SCK	PT1.6	I/O	S	數位輸入/輸出
			SCK	I/O	S	SPI通訊介面接口
10	-	PT1.7/BZ/SDA	PT1.7	I/O	S	數位輸入/輸出

HY15P43

Embedded 18-Bit Σ ADC

8-Bit RISC-like Mixed Signal Microcontroller



		BZ	O	C	蜂鳴器輸出端
		SDA	I/O	S	I2C 通訊介面引腳
13	-	PT7.7/PWM1/COM7			
		PT7.7	O	S	數位輸出
		PWM1	O	C	PWM1 輸出接口
		COM7	O	C	LED COM 輸出
14	11	PT7.6/PWM0/COM6			
		PT7.6	O	S	數位輸出
		PWM0	O	C	PWM0 輸出接口
		COM6	O	C	LED COM 輸出
15	12	PT7.5/COM5			
		PT7.5	O	S	數位輸出
		COM5	O	C	LED COM 輸出
16	13	PT7.4/COM4			
		PT7.4	O	S	數位輸出
		COM4	O	C	LED COM 輸出
17	14	SEG9/PT7.3			
		SEG9	O	A	LED Segment輸出
		PT7.3	O	S	數位輸出
18	15	SEG8/PT7.2			
		SEG8	O	A	LED Segment輸出
		PT7.2	O	S	數位輸出
19	16	SEG7/PT7.1			
		SEG7	O	A	LED Segment輸出
		PT7.1	O	S	數位輸出
20	17	SEG6/PT7.0			
		SEG6	O	A	LED Segment輸出
		PT7.0	O	S	數位輸出
21	18	SEG5/PT6.7			
		SEG5	O	A	LED Segment輸出
		PT6.7	O	S	數位輸出
22	19	SEG4/PT6.6			
		SEG4	O	A	LED Segment輸出
		PT6.6	O	S	數位輸出
23	20	SEG3/PT6.5			
		SEG3	O	A	LED Segment輸出
		PT6.5	O	S	數位輸出
24	-	SEG2/PT6.4			

		SEG2 PT6.4	O O	A S	LED Segment輸出 數位輸出
25	21	COM3	O	A	LED COM輸出
26	22	COM2	O	A	LED COM輸出
27	23	COM1	O	A	LED COM輸出
28	24	COM0	O	A	LED COM輸出
29	25	VLCD	P	P	BIE電壓源
30	26	VDD	P	P	晶片工作電壓源
31	-	PT2.0/XTO	I/O A	S A	數位輸入/輸出 外接振盪器輸出端
32	-	PT2.1/XTI	I/O A	S A	數位輸入/輸出 外接振盪器輸入端
39	27	VDDA	P	P	穩壓器輸出，類比電路電壓源
41	28	AI0	A	A	類比輸入通道
42	1	AI1	A	A	類比輸入通道
43	2	AI2	A	A	類比輸入通道
47	3	VSS	P	P	晶片工作電壓源接地端
Others	Others	NC	-	-	未使用

表 2-1 引腳定義與功能說明

HY15P43

Embedded 18-Bit $\Sigma\Delta$ ADC

8-Bit RISC-like Mixed Signal Microcontroller

2.4. 封裝片標記信息

2.4.1. LQFP 封裝片標記信息

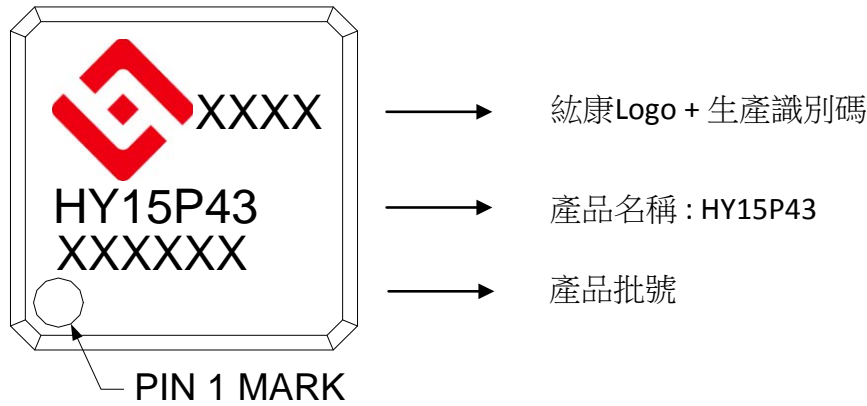

2.4.2. TSSOP28 封裝片標記信息

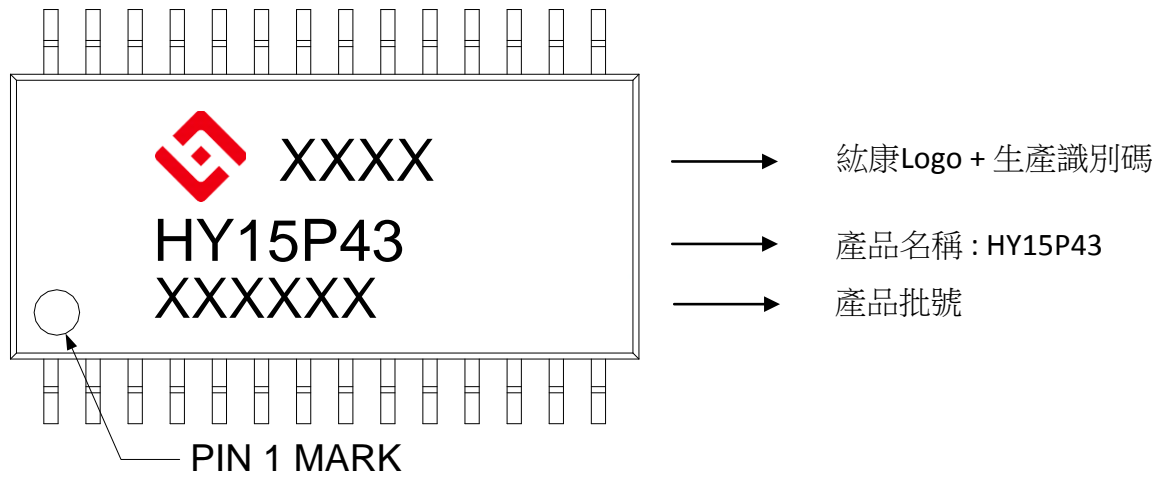

HY15P43

Embedded 18-Bit $\Sigma\Delta$ ADC

8-Bit RISC-like Mixed Signal Microcontroller

3. 應用電路

3.1. 橋式感測器 LED 顯示



圖 3-1 橋式感測器 LED 顯示應用電路

4. 功能概述

4.1. 內部方塊圖

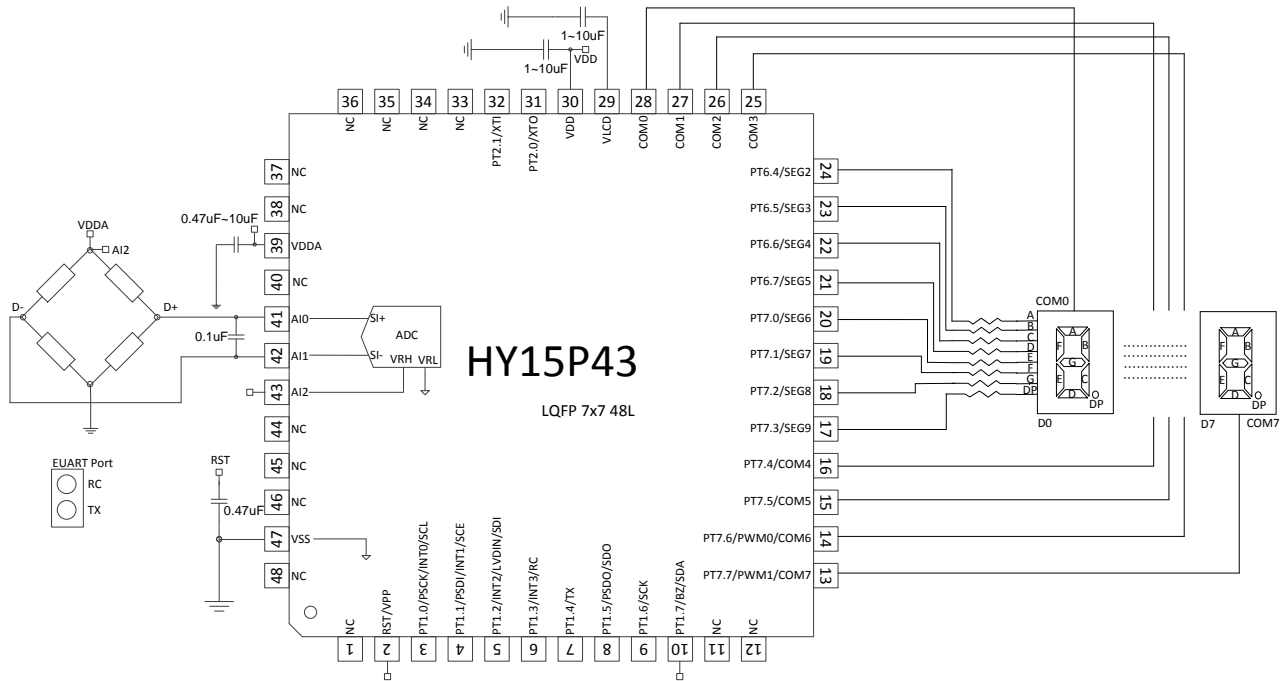

圖 4-1 HY15P43 內部方塊圖

4.2. 相關說明與支援文件

晶片功能相關使用說明書

DS-HY15P43

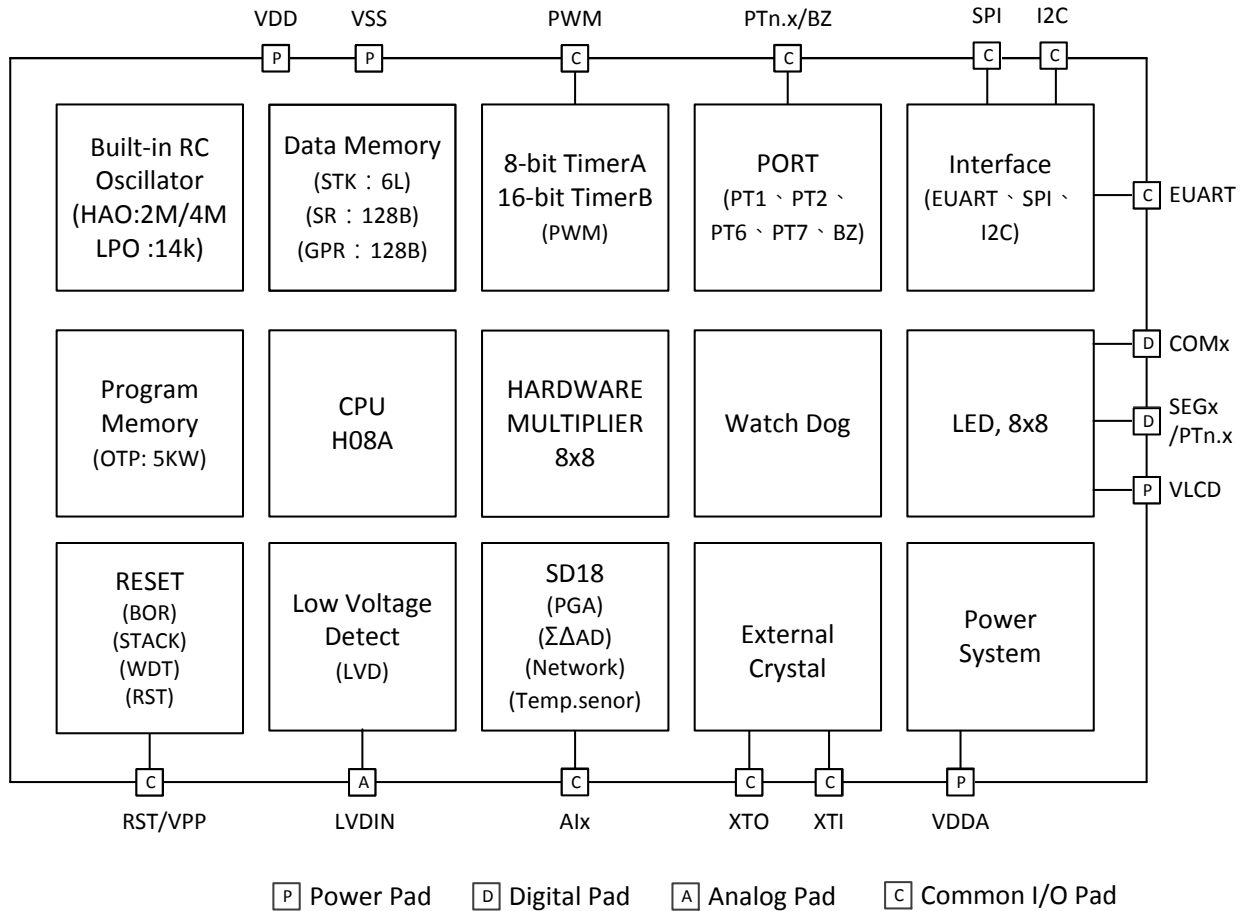
HY15P43 說明書

UG-HY15S50

HY15S50 使用說明書

APD-CORE002

H08A 指令集說明書

開發工具相關使用說明書

APD-HY15PIDE001

HY15P 系列開發工具軟體使用說明書

APD-HY15PIDE002

HY15P 系列開發工具硬體使用說明書

APD-OTP001

OTP 燒錄引腳資訊

產品生產相關使用說明書

APD-HY15PIDE004

HY15P 系列生產線專用燒錄器說明書

BDI-HY15P43

HY15P43 個別產品的裸片打線資訊

4.3. Clock System



圖 4-2 Clock System 方塊圖(一)



圖 4-3 Clock System 方塊圖(二)

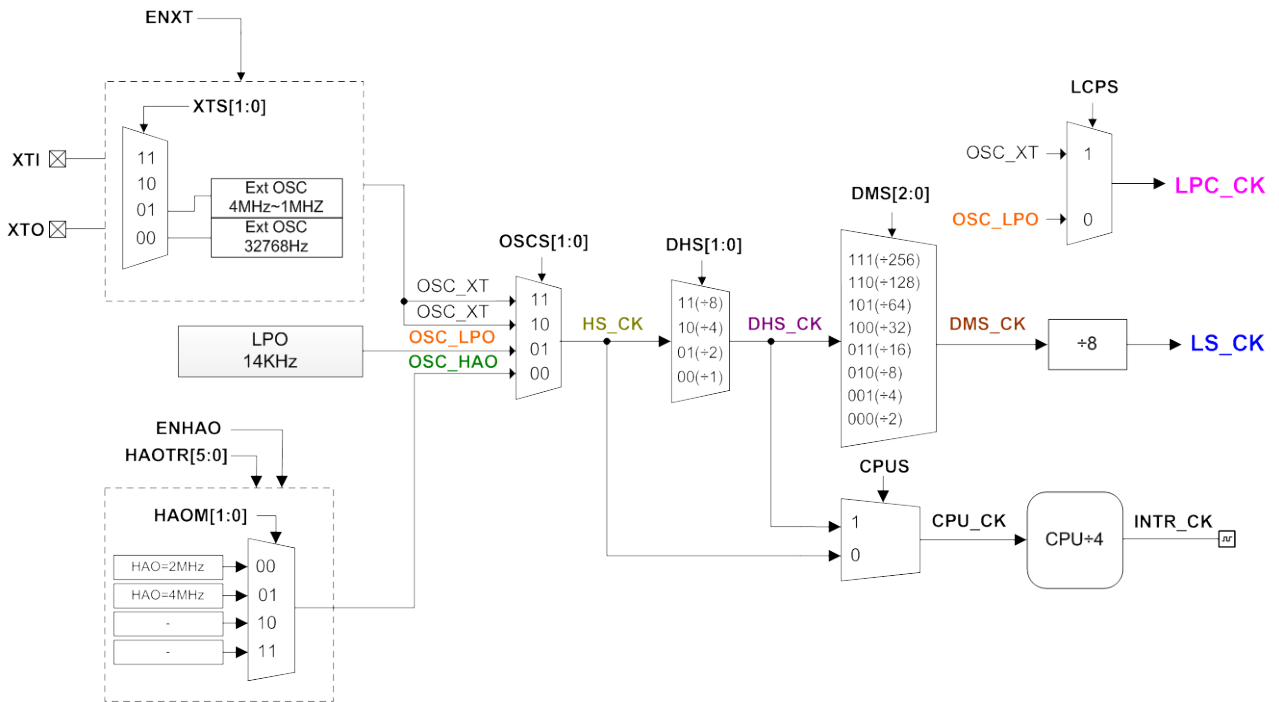

圖 4-4 Clock System 方塊圖(三)

4.4. Low Voltage Detect(LVD)

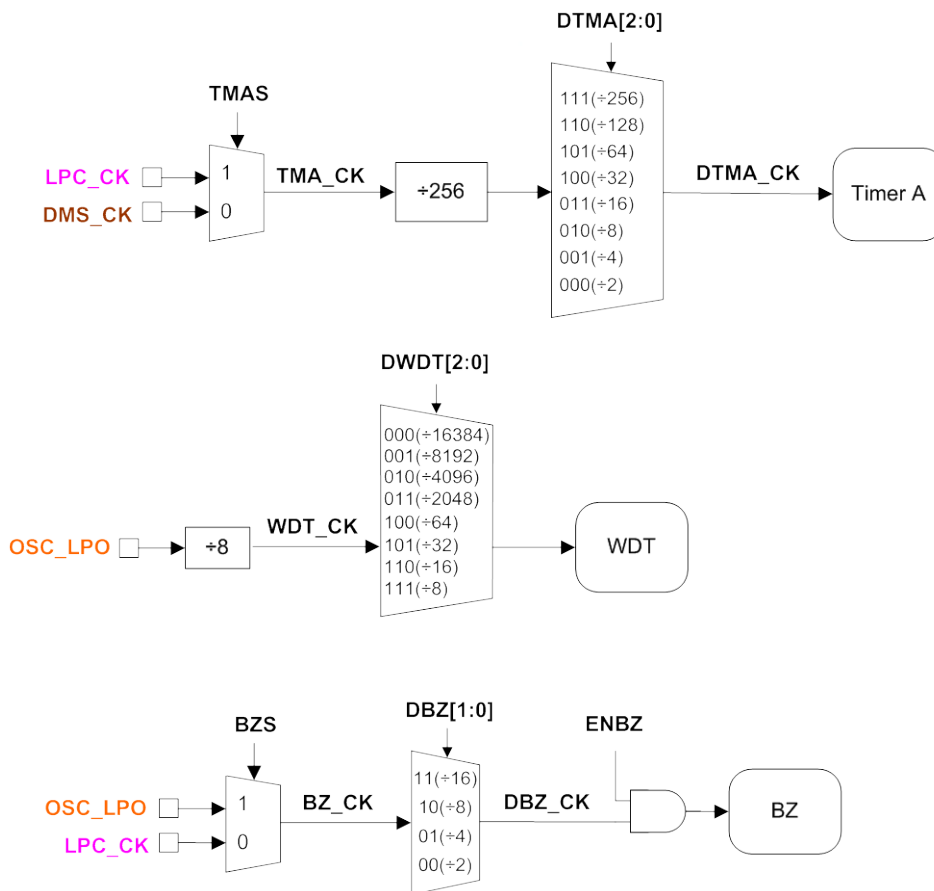

圖 4-5 Low Voltage Detect 方塊圖

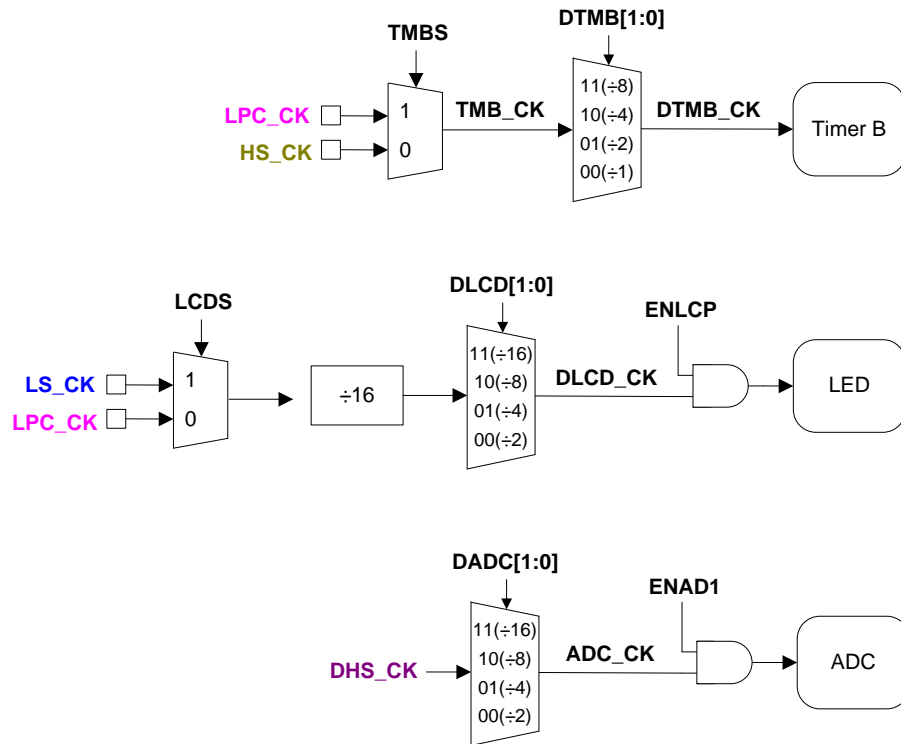
4.5. Reset

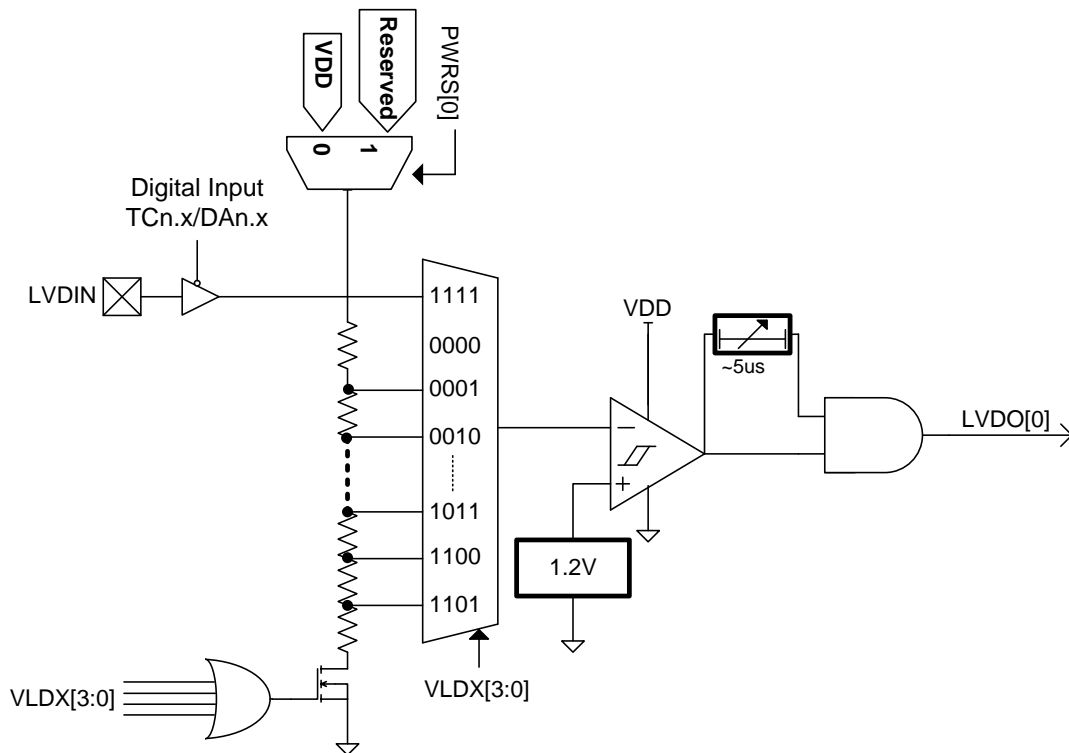

圖 4-6 Reset 方塊圖

4.6. Power System

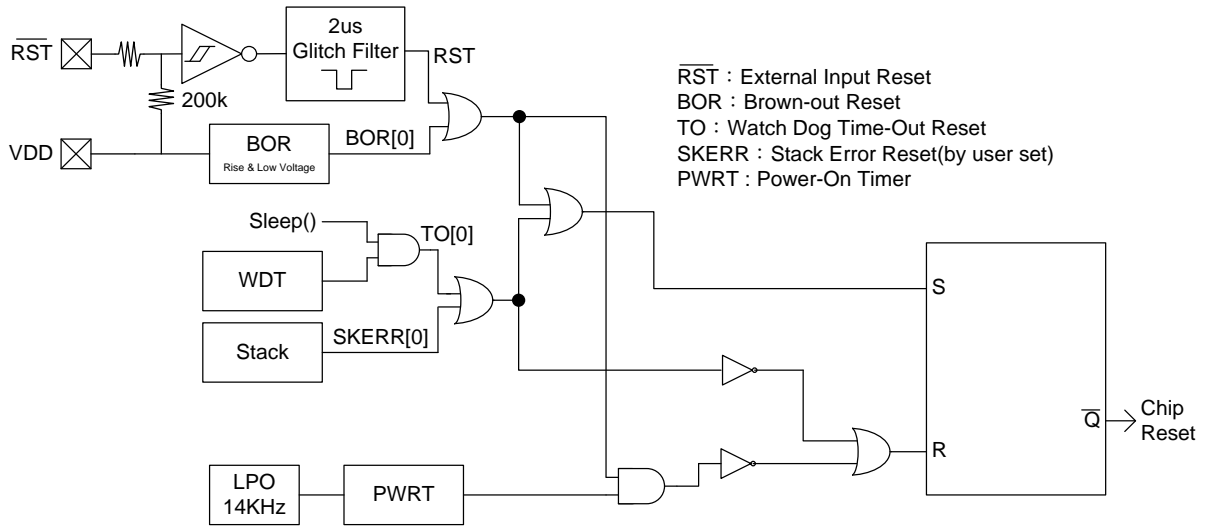

圖 4-7 Power System 方塊圖

4.7. SD18 Network

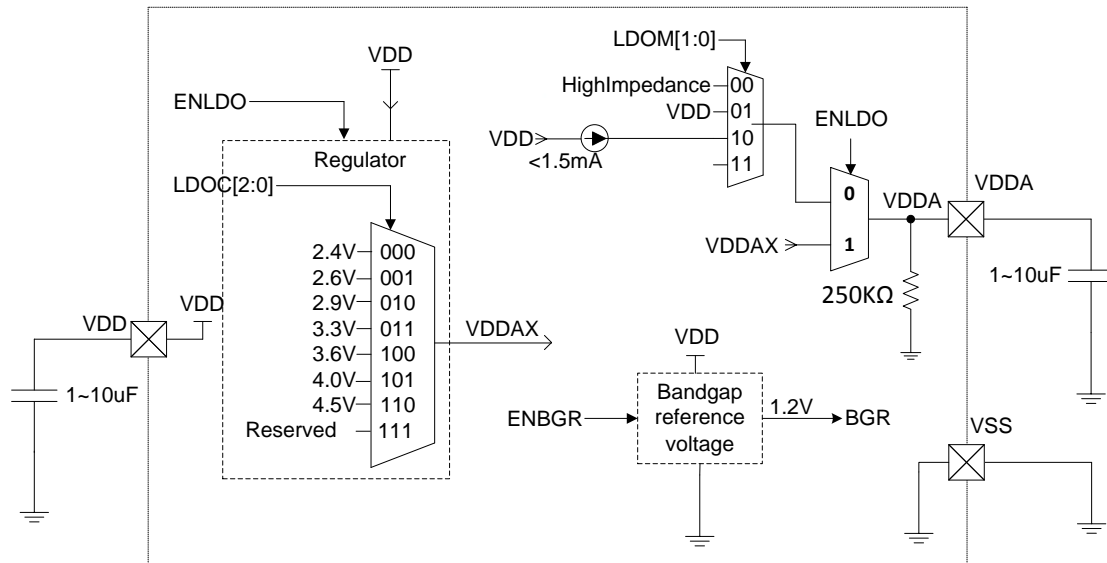

圖 4-8 SD18 Network 方塊圖

4.8. GPIO

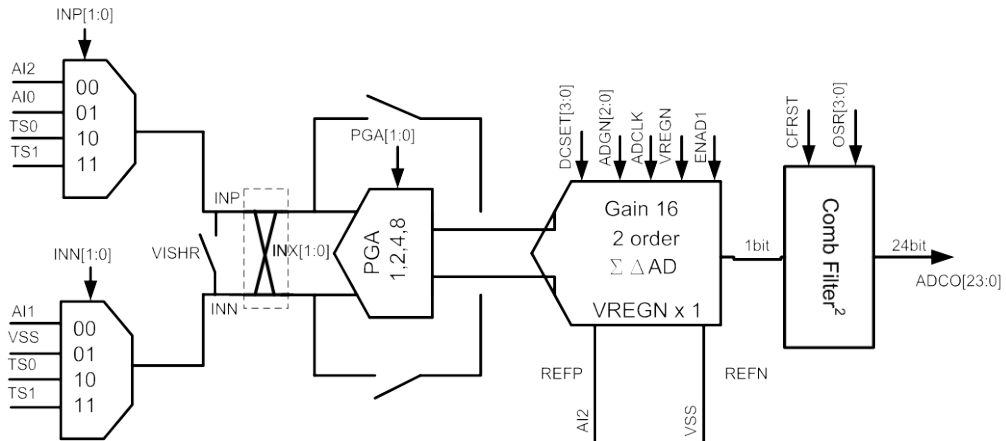

圖 4-9 GPIO 方塊圖

4.9. Watch Dog

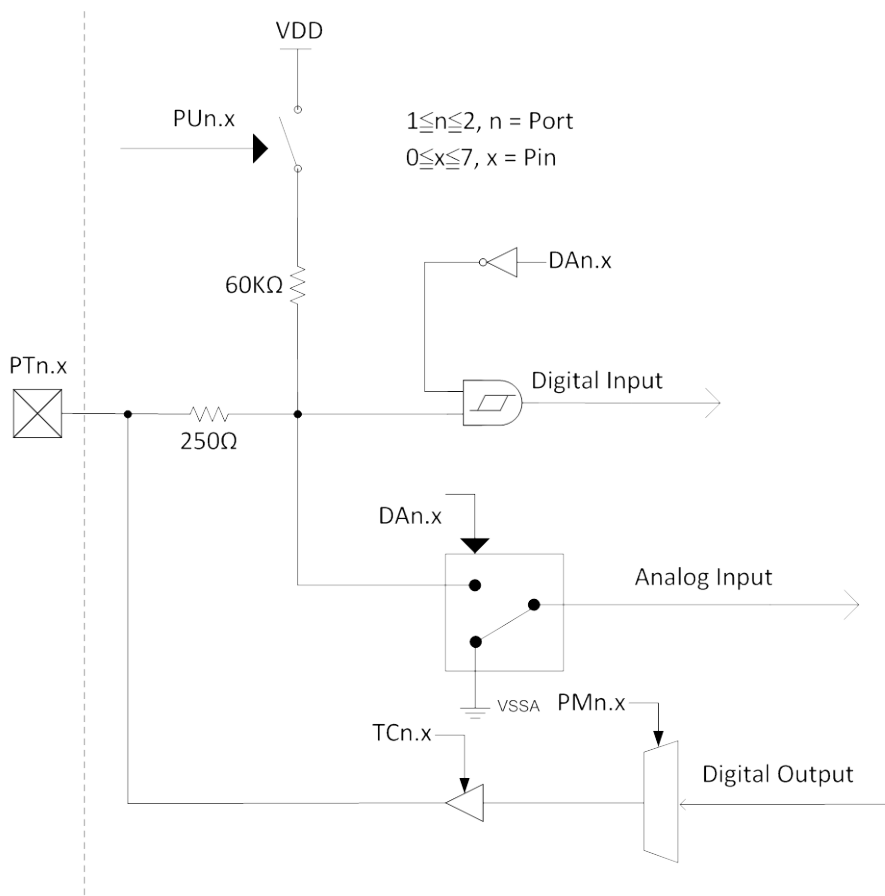

圖 4-10 Watch Dog 方塊圖

4.10.8-bit Timer A

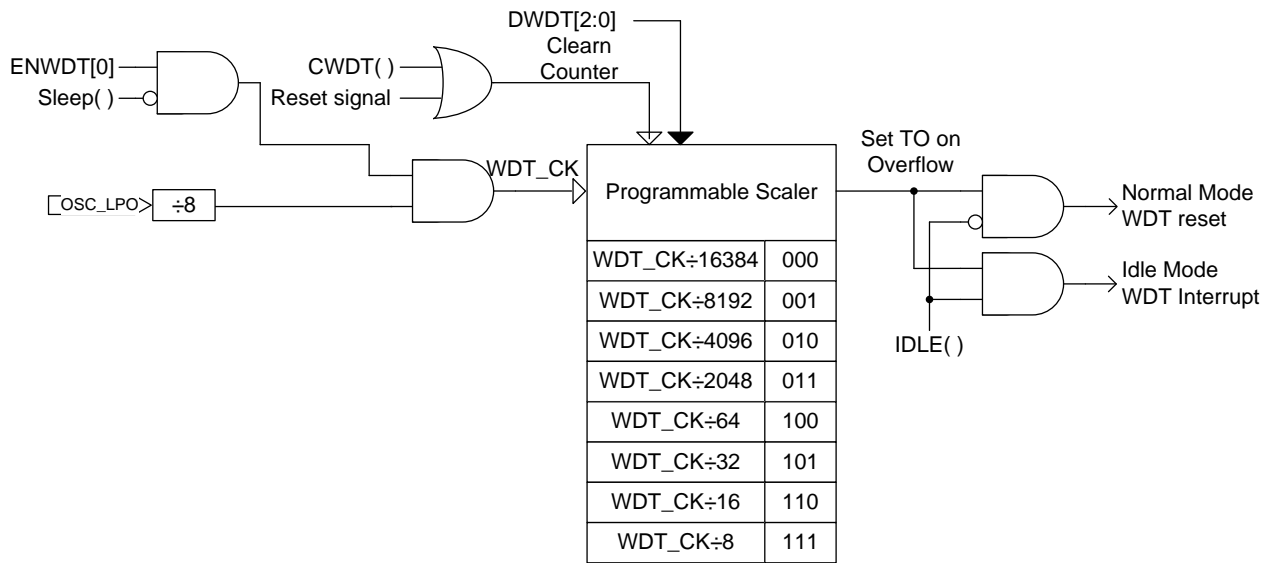

圖 4-11 8-bit Timer A 方塊圖

4.11. 16-bit Timer B

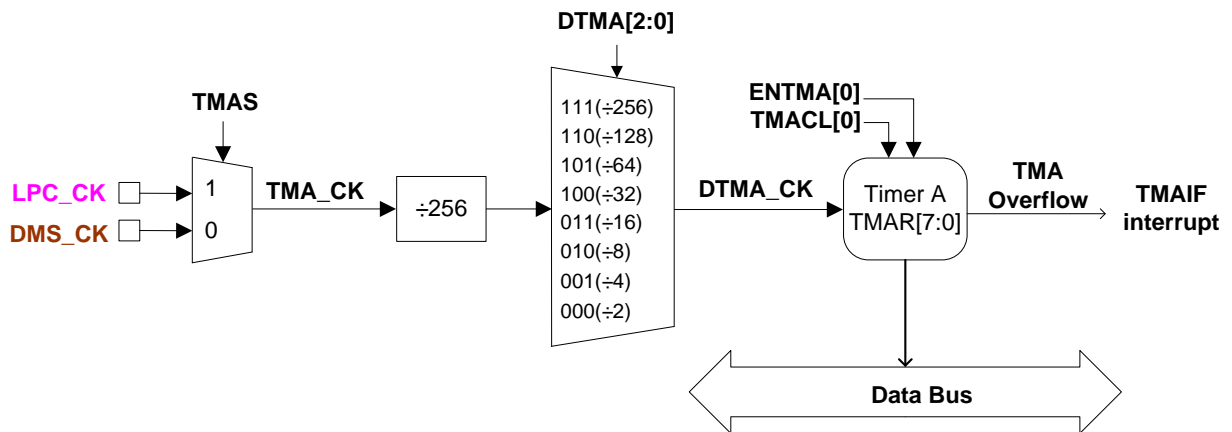

圖 4-12 16-bit Timer B 方塊圖

4.12. LED

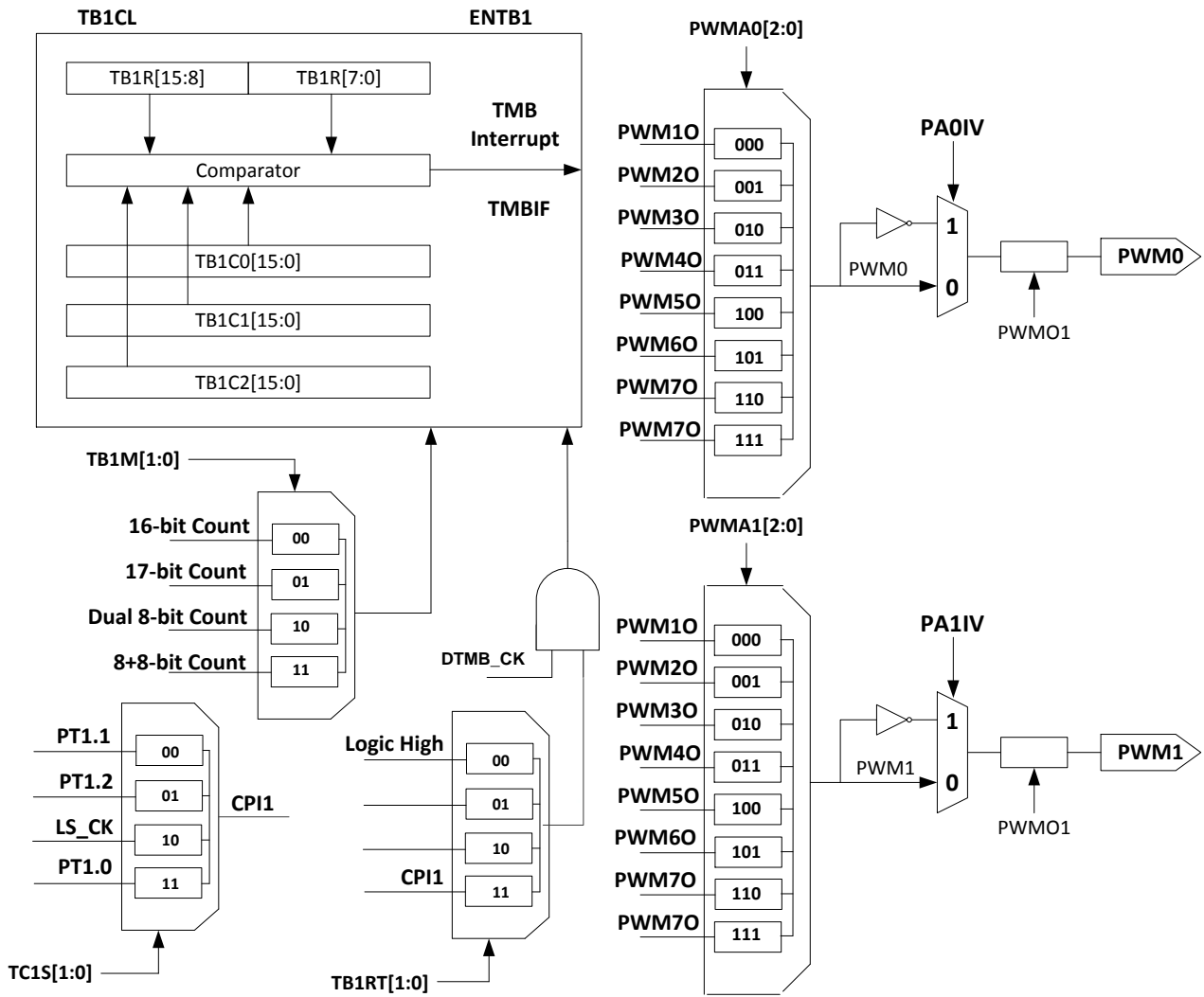

圖 4-13 LED 方塊圖

4.13. EUART

EUART TRANSMIT BLOCK DIAGRAM

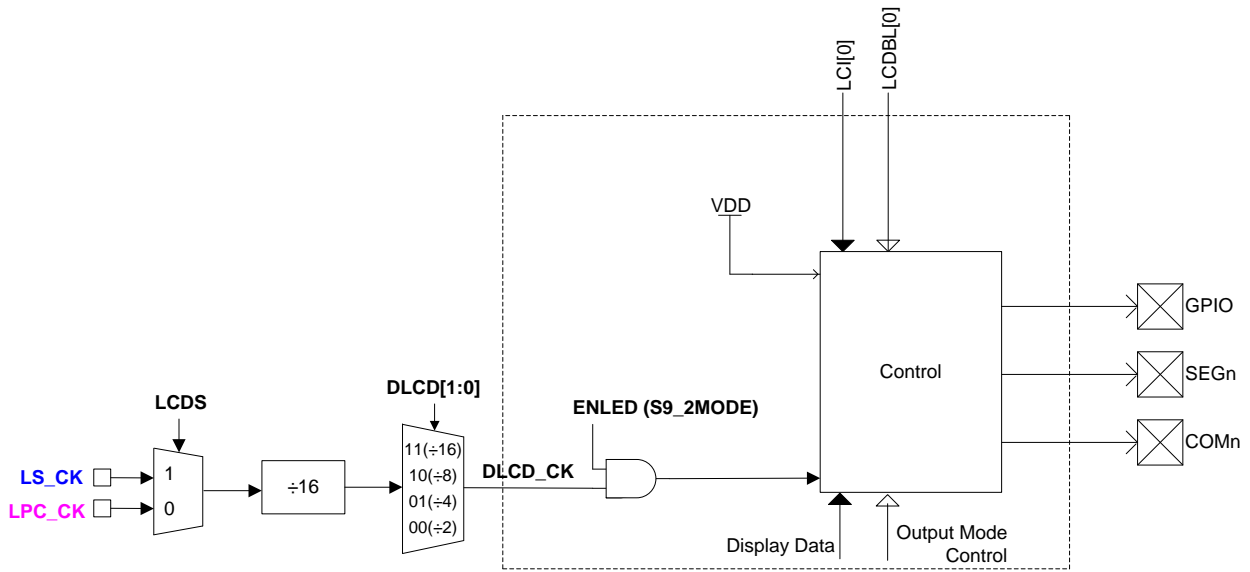

圖 4-14 EUART 傳送方塊圖

EUART 8-BITS RECEIVE BLOCK DIAGRAM

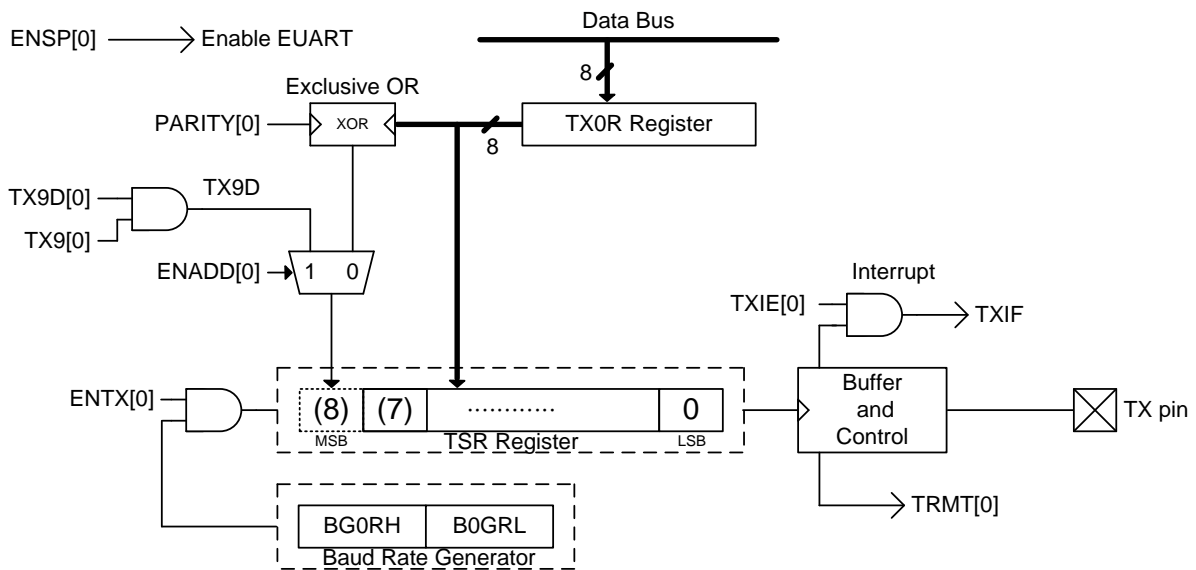
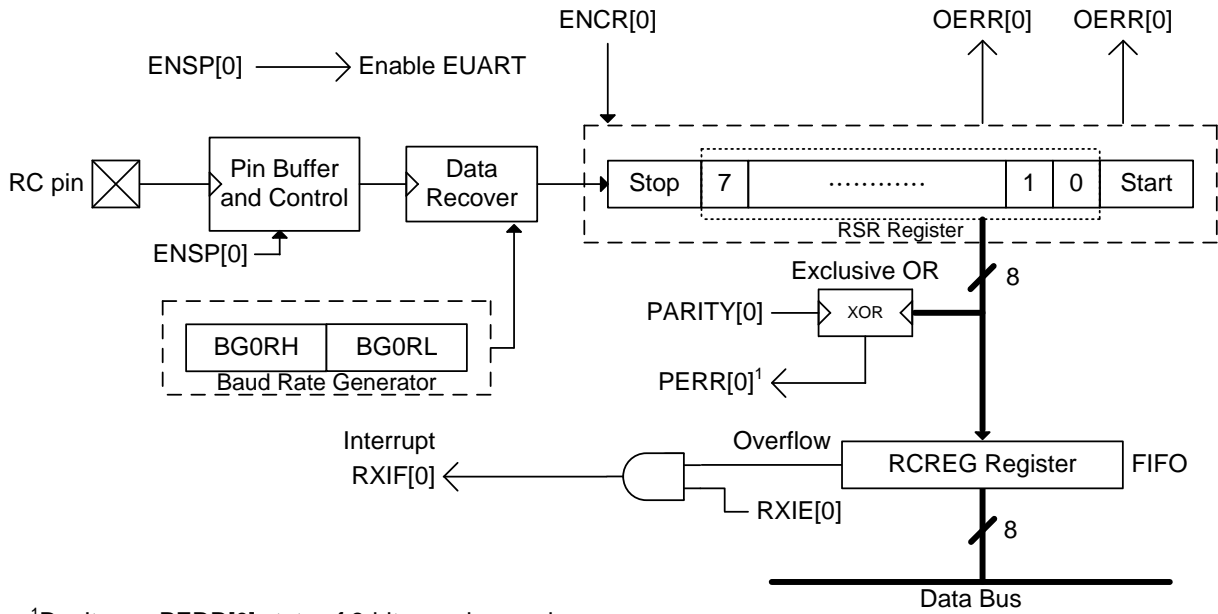

¹Don't care PERR[0] state of 8-bits receive mode

圖 4-15 EUART 8-bits 接收方塊圖

4.14. SPI



圖 4-16 SPI 方塊圖

4.15. I2C

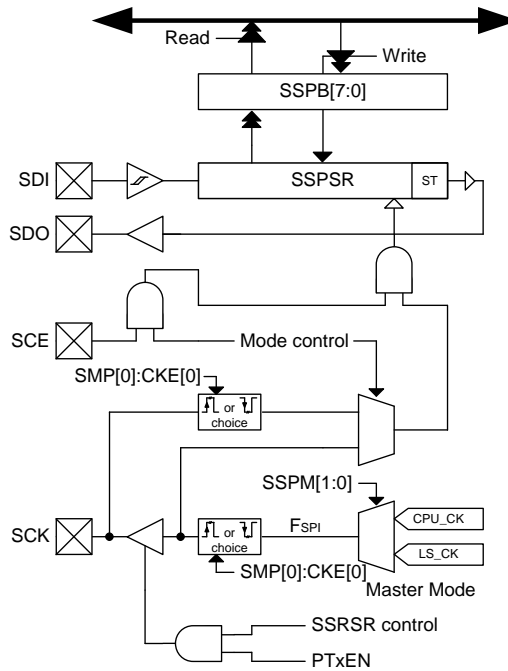

圖 4-17 I2C 方塊圖

5. 暫存器列表

“-”no use, “*”read/write, “w”write, “r”read, “r0”only read 0, “r1”only read 1, “w0”only write 0, “w1”only write 1
“\$”for event status, “x”unimplemented bit, “x”unknown, “u”unchanged, “d”depends on condition

Address	Name	Bit 7	Bit 6	Bit 5	Bit 4	Bit 3	Bit 2	Bit 1	Bit 0	ARST	IRST	R/W
000h	INDF0	Contents of FSR0 to address data memory value of FSR0 not changed								xxxx xxxx	uuuu uuuu	*r0*
001h	POINC0	Contents of FSR0 to address data memory value of FSR0 post-incremented								xxxx xxxx	uuuu uuuu	*r0*
002h	PODEC0	Contents of FSR0 to address data memory value of FSR0 post-decremented								xxxx xxxx	uuuu uuuu	*r0*
003h	PRINC0	Contents of FSR0 to address data memory value of FSR0 pre-incremented								xxxx xxxx	uuuu uuuu	*r0*
004h	PLUSW0	Contents of FSR0 to address data memory value of FSR0 offset by W								xxxx xxxx	uuuu uuuu	*r0*
005h	INDF1	Contents of FSR1 to address data memory value of FSR0 not changed								xxxx xxxx	uuuu uuuu	*r1*
006h	POINC1	Contents of FSR1 to address data memory value of FSR0 post-incremented								xxxx xxxx	uuuu uuuu	*r1*
007h	PODEC1	Contents of FSR1 to address data memory value of FSR0 post-decremented								xxxx xxxx	uuuu uuuu	*r1*
008h	PRINC1	Contents of FSR1 to address data memory value of FSR1 pre-incremented								xxxx xxxx	uuuu uuuu	*r1*
009h	PLUSW1	Contents of FSR1 to address data memory value of FSR0 offset by W								xxxx xxxx	uuuu uuuu	*r1*
00Fh	FSR0H	-	-	-	-	-	-	-	FSR0[8]	... xxxx	... uuuu	*r0*
010h	FSR0L	Indirect Data Memory Address Pointer 0 Low Byte, FSR0[7:0]								xxxx xxxx	uuuu uuuu	*r0*
011h	FSR1H	-	-	-	-	-	-	-	FSR1[8]xxxuuu	*r1*
012h	FSR1L	Indirect Data Memory Address Pointer 0 Low Byte, FSR1[7:0]								xxxx xxxx	uuuu uuuu	*r1*
016h	TOSH	-	-	-	-	TOS[11]	TOS[10]	TOS[9]	TOS[8]	..xx xxxx	..uu uuuu	*r0*
017h	TOSL	Top-of-Stack Low Byte (TOS<7:0>)								xxxx xxxx	uuuu uuuu	*r0*
018h	SKCN	SKFL	SKUN	SKOV	-	-	SKPRT[2:0]		000.0000	u\$\$.\$\$\$	rw0,rw0,rw0,-	*r0*
01Ah	PCLATH	-	-	-	-	PC[11]	PC[10]	PC[9]	PC[8]	..00 0000	..00 0000	*r0*
01Bh	PCLATL	PC Low Byte for PC<7:0>								0000 0000	0000 0000	*r0*
01Dh	TBLPTRH	-	-	-	Program Memory Table Pointer High Byte (TBLPTR<12:8>)					..xx xxxx	..uu uuuu	*r0*
01Eh	TBLPTRL	Program Memory Table Pointer Low Byte (TBLPTR<7:0>)								xxxx xxxx	uuuu uuuu	*r0*
01Fh	TBLDH	Program Memory Table Latch High Byte								xxxx xxxx	uuuu uuuu	*r0*
020h	TBLDL	Program Memory Table Latch Low Byte								xxxx xxxx	uuuu uuuu	*r0*
021h	PRODH	Product Register of Multiply High Byte								xxxx xxxx	uuuu uuuu	*r0*
022h	PRODL	Product Register of Multiply Low Byte								xxxx xxxx	uuuu uuuu	*r0*
023h	INTE0	GIE	-	ADIE	WDTIE	TB1IE	TMAIE	E1IE	E0IE	0000 0000	0uuu uuuu	*r0*
024h	INTE1	-	SPIE	TXIE	RCIE	I2CERIE	I2CIE	E3IE	E2IE	0000 0000	uuuu uuuu	*r0*
026h	INTF0	-	-	ADIF	WDTIF	TB1IF	TMAIF	E1IF	E0IF	..00 0000	..uu uuuu	*r0*
027h	INTF1	-	SPIIF	TXIF	RCIF	I2CERIF	I2CIF	E3IF	E2IF	0000 0000	uuuu uuuu	*r0*
029h	WREG	Working Register								xxxx xxxx	uuuu uuuu	*r0*
02Ah	BSRCN	-	-	-	-	-	-	-	BSR[0]	... xxxx	... uuuu	*r0*
02Bh	MSTAT	-	-	-	C	DC	N	OV	Z	...x xxxx	...u uuuu	*r0*
02Ch	PSTAT	BOR	PD	TO	IDL	RST	SKERR	-	-	\$000 \$00.	u\$\$u u\$\$u.	rw0,rw0,rw0,rw0,rw0,rw0,-
02Eh	BIECN	1	ENBVD		VPPHV	ENBCP	BIEWR	BIERD	1... \$000	1... \$uuu	r1,r1,r1,r1,r1,r1,r1,r1	
02Fh	BIEARH	IFR & eIFR	1		1	1	1	1	1	0... xxxx	u... uuuu	*r0*
030h	BIEARL	BIE Address Register as BIEAL[5:0]								xxxx xxxx	uuuu uuuu	*r0*
031h	BIEDRH	BIE High Byte Data Register								xxxx xxxx	uuuu uuuu	*r0*
032h	BIEDRL	BIE Low Byte Data Register								xxxx xxxx	uuuu uuuu	*r0*
033h	PWRCN	ENBGR	LDOC[2:0]		LDOM[0]	LDOM	ENLDO	CSFON	0000 0000	uuuu u00u	*r0*	
034h	OSCCN0	OSCS[1:0]		DHS[1:0]	DMS[2:0]		CUPS	0000 0000	uuuu uuuu	*r0*		
035h	OSCCN1	LCPS	DADC[1:0]		DTMB[1:0]		TMBS	LCDS	0000 0000	uuuu uu.	*r0*	
036h	OSCCN2	DLCD[1:0]		ENXT	XTS[1:0]		HAOM0	ENHAO	0000 0011	uuuu uu11	*r0*	
037h	WDTCN	ENBZ	BZS	ENWDT		DWDWT[2:0]		0000 0000	uuuu \$000	*r0*		
038h	TMACN	ENTMA	TMACL	TMAS	DTMA[2:0]		-	-	0000 00..	u0uu uu..	*r0*	
039h	TMAR	TMA counter Register								0000 0000	uuuu uuuu	rw0,rw0,rw0,rw0,rw0,rw0,rw0
03Ah	AD1H	ADC1 conversion high byte data register								..00 0000	..uu uuuu	*r0*
03Bh	AD1M	ADC1 conversion middle byte data register								0000 0000	uuuu uuuu	*r0*
03Ch	AD1L	ADC1 conversion low byte data register								0000 0000	uuuu uuuu	*r0*
03Dh	AD1CN0	ENAD1	-	-	OSR[3:0]			CMFR	000. 0000	uuu. uuuu	*r0*	
03Eh	AD1CN1	-	-	VREGN	PGAGN[1:0]		ADGN[2:0]		xxxx xxxx	uuuu uuuu	*r0*	
03Fh	AD1CN2	-	-	-	DCSET[3:0]			xxxx xxxx	uuuu uuuu	*r0*		
040h	AD1CN3	-	-	INP[1:0]		-	INN[1:0]		xxxx xxxx	uuuu uuuu	*r0*	
041h	AD1CN4	-	VRH[0]	-	-	INX[1:0]		-	INIS	0010 0000	uuuu uuuu	*r0*
042h	AD1CN5	-	-	-	-	-	ENTPS	TPSCH	0000 0000	uuuu uuuu	*r0*	

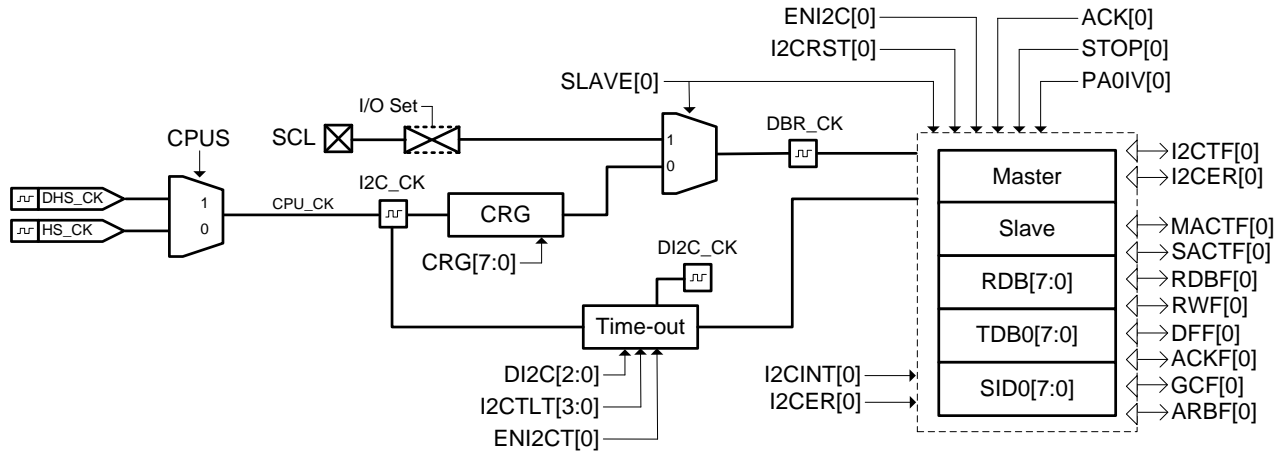
表 5-1 資料記憶體列表

“-”no use,“*”read/write,“w”write,“r”read,“r0”only read 0,“r1”only read 1,“w0”only write 0,“w1”only write 1
 “\$”for event status,“.”unimplemented bit,“x”unknown,“u”unchanged,“d”depends on condition

Address	Name	Bit 7	Bit 6	Bit 5	Bit 4	Bit 3	Bit 2	Bit 1	Bit 0	ARST	IRST	R/W	
043h	CSFCN0	SKRST	x	HAOTR[5:0]					0u*	
045h	LVDCN	-	-	PWRS	LVDS[3:0]				LVDO	0000 0000	uuuu uuuu*	
04Eh	TB1Flag	-	-	PWM6A	PWM5A	PWM4A	PWM3A	PWM2A	PWM1A	..00 0000	..uu uuuu	..r,r,r,r,r,r	
04Fh	TB1CN0	ENTB1	TB1M[1:0]		TB1RT[1:0]		TB1CL	-	-	0000 0000	uuuu u0uu,rw1,*	
050h	TB1CN1	PA1IV	PWMA1[2:0]			PA0IV	PWMA0[2:0]			0000 0000	uuuu uuuu*	
051h	TB1RH	TimerB1 counter Register [15:8]								xxxx xxxx	uuuu uuuu	r,r,r,r,r,r,r	
052h	TB1RL	TimerB1 counter Register [7:0]								xxxx xxxx	uuuu uuuu	r,r,r,r,r,r,r	
053h	TB1COH	TimerB1 counter Condition Register [15:8]								xxxx xxxx	uuuu uuuu*	
054h	TB1COL	TimerB1 counter Condition Register [7:0]								xxxx xxxx	uuuu uuuu*	
055h	TB1CH	TimerB1 counter Condition Register [15:8]								xxxx xxxx	uuuu uuuu*	
056h	TB1CL	TimerB1 counter Condition Register [7:0]								xxxx xxxx	uuuu uuuu*	
057h	TB1C2H	TimerB1 counter Condition Register [15:8]								xxxx xxxx	uuuu uuuu*	
058h	TB1C2L	TimerB1 counter Condition Register [7:0]								xxxx xxxx	uuuu uuuu*	
059h	TCCN0	-	TC1S[1:0]		-	-	-	-	-	0000 0000	uuuu uuuu*	
05Eh	SSPCN0	ENSSP	CKP	CKE	SMP	-	-	SSPM[1:0]		0000 ..00	uuuu ..uu*	
05Fh	SSPSTA	SSPBY	SSPOV	-	-	-	-	-	BF	00...00	uu...uu*	
060h	SSPBUF	SSP Receive/Transmit Buffer Register								xxxx xxxx	uuuu uuuu*	
061h	CFG	-	-	-	-	-	I2CRST	ENI2CT	ENI2C	0000 0000uuuu*	
062h	ACT	SLAVE	ADR10	SLAVE24	I2CER	START	STOP	I2CINT	ACK	0000 0000	uuuu uuuu*	
063h	STA	MACTF	SACTF	RDBF	RWF	DFE	ACKF	GCF	ARBF	0001 0000	uuuu uuuu*	
064h	CRG	CRG[7:0]								0000 0000	uuuu uuuu*	
065h	TOC	I2CTF	DI2C[2:0]			I2CTLTL[3:0]				0000 0000	uuuu uuuu*	
066h	RDB	RDB[7:1]							RDB[0]	xxxx xxxx	uuuu uuuu*	
067h	TDB0	TDB0[7:1]							TDB0[0]	xxxx xxxx	uuuu uuuu*	
068h	SID0	SID0[7:1].The corresponding address of the 7-bit mode or address 10-bit mode 15-9bit								SID0V[0]	0000 0000	uuuu uuuu*
069h	UROCN	ENSP	ENTX	TX9	TX9D	PARITY	-	-	WUE	0000 0..0	uuuu u..u*	
06Ah	UROSTA	-	RC9D	PERR	FERR	OERR	RCIDL	TRMT	ABDOVF	..00 0010	..uu uuuu	..r,r,r,r,r,r,rw0	
06Bh	BA0CN	-	-	-	-	ENCR	RC9	ENADD	ENABD 0000 uuuu*	
06Ch	BG0RH	-	-	-	Baud Rate Generator Register High Byte					...x xxxx uuuu*	
06Dh	BG0RL	Baud Rate Generator Register Low Byte								xxxx xxxx	uuuu uuuu*	
06Eh	TX0R	UART Transmit Register								xxxx xxxx	uuuu uuuu*	
06Fh	RCREG	UART Receive Register								xxxx xxxx	uuuu uuuu	r,r,r,r,r,r,r	
070h	PT1	PT1.7	PT1.6	PT1.5	PT1.4	PT1.3	PT1.2	PT1.1	PT1.0	xxxx xxxx	xxxx xxxx*	
071h	TRISC1	TC1.7	TC1.6	TC1.5	TC1.4	TC1.3	TC1.2	TC1.1	TC1.0	0000 0000	uuuu uuuu*	
072h	PT1DA	-	-	-	-	-	DA1.2	-	-	0000 0000	uuuu uuuu*	
073h	PT1PU	PU1.7	PU1.6	PU1.5	PU1.4	PU1.3	PU1.2	PU1.1	PU1.0	0000 0000	uuuu uuuu*	
074h	PT1M1	-	-	-	-	INTEG1[1:0]		INTEG0[1:0]		0000 0000	uuuu uuuu*	
075h	PT1M2	-	PM1.7[0]	-	PM1.6[0]	-	PM1.5[0]	-	PM1.4[0]	xxxx xxxx	xxxx xxxx*	
076h	PT1INT	INTEG7	INTEG6	INTEG5	INTEG4	INTEG3	INTEG2	-	-	0000 0000	uuuu uuuu*	
077h	PT2	-	-	-	-	-	-	PT2.1	PT2.0	0000 0000	uuuu uuuu*	
078h	TRISC2	-	-	-	-	-	-	TC2.1	TC2.0	0000 0000	uuuu uuuu*	
07Ah	PT2PU	-	-	-	-	-	-	PU2.1	PU2.0	0000 0000	uuuu uuuu*	
080h ~ 017Fh	General Purpose Register as 256Byte								uuuu uuuu	uuuu uuuu*		
180h	LCDCN1	ENLCP	LCDV[2:0]			ENLB	SEL_PCLK	PWMO1	-	0000 00..	uuuu uu..*	
181h	LCDCN2	S9_2MODE		S13M	S12M	S11M	S10M	LCDL	LCI	0000 00..	uuuu uu..*	
182h	LED0	Display (LED) and GPIO data register 0								xxxx xxxx	uuuu uuuu*	
183h	LED1	Display (LED) and GPIO data register 1								xxxx xxxx	uuuu uuuu*	
184h	LED2	Display (LED) and GPIO data register 2								xxxx xxxx	uuuu uuuu*	
185h	LED3	Display (LED) and GPIO data register 3								xxxx xxxx	uuuu uuuu*	
186h	LED4	Display (LED) and GPIO data register 4								xxxx xxxx	uuuu uuuu*	
187h	LED5	Display (LED) and GPIO data register 5								xxxx xxxx	uuuu uuuu*	
188h	LED6	Display (LED) data register 6								xxxx xxxx	uuuu uuuu*	
189h	LED7	Display (LED) data register 7								xxxx xxxx	uuuu uuuu*	

表 5-2 資料記憶體列表(續)

6. 電氣特性

Absolute Maximum Ratings :

Absolute maximum ratings over operating free-air temperature (unless otherwise noted)

Voltage applied at V _{DD} to V _{SS}	-0.2 V to 6.0 V
Voltage applied to any pin	-0.2 V to V _{DD} + 0.3 V
Voltage applied to RST/VPP pin	-0.2 V to 8.5 V
Diode current at any device terminal	±2 mA
Storage temperature, Tstg: (unprogrammed device)	-55°C to 125°C
(programmed device)	-40°C to 85°C
Total power dissipation.	0.5w
Maximum output current sink by any I/O pin.	10mA

6.1. Recommended operating conditions

T_A = -40°C ~ 85°C, unless otherwise noted

Sym.	Parameter		Test Conditions	Min.	Typ.	Max.	unit	
V _{DD}	Supply Voltage		All digital peripherals and CPU	2.2		5.5	V	
V _{DDA}	Supply Voltage		Analog peripherals	2.4		4.5		
V _{SS}	Supply Voltage			0		0		
XT	External Oscillator Frequency	Watch crystal	V _{DD} = 2.2V, ENXT[0]=1	XTS[1:0]=0x		32768	Hz	
		Ceramic resonator		XTS[1:0]=10		450K		4M
		Crystal		XTS[1:0]=11		1M		4M

6.2. Internal RC Oscillator

T_A = 25°C, VDD = 3.0V, unless otherwise noted

Sym.	Parameter	Test Conditions	Min.	Typ.	Max.	unit
HAO	High Speed Oscillator frequency	ENHAO[0]=1, HAOM[1:0]=00	-20%	2	+20%	MHz
		ENHAO[0]=1, HAOM[1:0]=01	-20%	4	+20%	MHz
LPO	Low Power Oscillator frequency	VDD supply voltage be enable LPO	-20%	14.5	+20%	KHz

6.3. Supply current into VDD excluding peripherals current

$T_A = 25^\circ\text{C}, V_{DD} = 3.3\text{V}, \text{OSC_LPO} = 14.5\text{KHz}$, unless otherwise noted

Sym.	Parameter	Test Conditions	Min.	Typ.	Max.	unit
I _{AM1}	Active mode 1	OSC_CY = off, OSC_HAO = 4MHz, CPU_CK = 4MHz		310	620	uA
I _{AM2}	Active mode 2	OSC_CY = off, OSC_HAO = 2MHz, CPU_CK = 2MHz		200	400	uA
I _{AM3}	Active mode 3	OSC_CY = off, OSC_HAO = 2MHz, CPU_CK = 1MHz		150	300	uA
I _{LP1}	Low Power 1	OSC_CY = 32768Hz, OSC_HAO = off, CPU_CK = LPO, Idle state		3	5	uA
I _{LP2}	Low Power 2	OSC_CY = off, OSC_HAO = off, CPU_CK = LPO, Idle state		1.1	2.5	uA
I _{LP3}	Low Power 3	OSC_CY = off, OSC_HAO = off, CPU_CK = off, Sleep state		0.4	1.5	uA

OSC_CY : External Oscillator frequency.

OSC_HAO : Internal High Accuracy Oscillator frequency.

CPU_CK : CPU core work frequency.

$T_A = 25^\circ\text{C}, V_{DD} = 5.5\text{V}, \text{OSC_LPO} = 14.5\text{KHz}$, unless otherwise noted

Sym.	Parameter	Test Conditions	Min.	Typ.	Max.	unit
I _{AM1}	Active mode 1	OSC_CY = off, OSC_HAO = 4MHz, CPU_CK = 4MHz		500	1000	uA
I _{AM2}	Active mode 2	OSC_CY = off, OSC_HAO = 2MHz, CPU_CK = 2MHz		320	640	uA
I _{AM3}	Active mode 3	OSC_CY = off, OSC_HAO = 2MHz, CPU_CK = 1MHz		270	540	uA
I _{LP1}	Low Power 1	OSC_CY = 32768Hz, OSC_HAO = off, CPU_CK = LPO, Idle state		5.5	15	uA
I _{LP2}	Low Power 2	OSC_CY = off, OSC_HAO = off, CPU_CK = LPO, Idle state		2.1	5	uA
I _{LP3}	Low Power 3	OSC_CY = off, OSC_HAO = off, CPU_CK = off, Sleep state		0.5	2	uA

OSC_CY : External Oscillator frequency.

OSC_HAO : Internal High Accuracy Oscillator frequency.

CPU_CK : CPU core work frequency.

6.4. Port 1~2, 6~7

$T_A = 25^\circ\text{C}, V_{DD} = 3.0\text{V}$, unless otherwise noted

Sym.	Parameter	Test Conditions	Min.	Typ.	Max.	unit
Input voltage and Schmitt trigger and leakage current and timing						
V _{IH}	High-Level input voltage				0.7*VDD	V
V _{IL}	Low-Level input voltage		0.3*VDD			
V _{hys}	Input Voltage hysteresis(V _{IH} - V _{IL})			0.3*VDD		V
I _{LKG}	Leakage Current				0.1	uA
R _{PU}	Port pull high resistance			60		kΩ
Output voltage and current and frequency						
V _{OH}	High-level output voltage	VDD<4V, I _{OH} =10mA,	V _{DD} -0.4			V
		VDD>=4V, I _{OH} =15mA,	V _{DD} -0.4			
V _{OL}	Low-level output voltage	VDD<4V, I _{OL} =-10mA	V _{SS} +0.3			V
		VDD>=4V, I _{OL} =-15mA	V _{SS} +0.3			
I _{OH}	High-level output source current (SEG and COM port)	VDD=3V, V _{OH} =V _{DD} -0.4	10			mA
		VDD=4V, V _{OH} =V _{DD} -0.4	15			
I _{OL}	Low-level output sink current (SEG port only)	VDD=3V, V _{OL} =V _{SS} +0.3	10			mA
		VDD=4V, V _{OL} =V _{SS} +0.4	20			
I _{OL}	Low-level output sink current (COM port only)	VDD=3V, V _{OL} =V _{SS} +0.3	20			mA
		VDD=4V, V _{OL} =V _{SS} +0.4	40			

6.5. Reset(Brownout, Low Voltage Detect)

$T_A = 25^\circ\text{C}$, $V_{DD} = 3.0\text{V}$, unless otherwise noted

Sym.	Parameter	Test Conditions	Min.	Typ.	Max.	unit			
BOR	Pulse length needed to accepted reset internally, t_{d-LVR}		2			us			
	V_{DD} Start Voltage to accepted reset internally (L \rightarrow H), V_{LVR}		1.6	1.85	2.1	V			
	Hysteresis, $V_{HYS-LVR}$			30		mV			
RST	Pulse length needed as RST/VPP pin to accepted reset internally, t_{d-RST}		2			us			
	Input Voltage to accepted reset voltage			1.1		V			
	Reset release voltage			2		V			
LVD	Operation current, I_{LVD}			10		uA			
	External input voltage to compare reference voltage		1.15	1.2	1.25	V			
	Compare reference voltage temperature drift	$T_A = -40^\circ\text{C} \sim 85^\circ\text{C}$		50		ppm/ $^\circ\text{C}$			
	Detect V_{DD} voltage rang by user option, V_{SVS} $VLDx[3:0]=1110b$		-0.1V	4.0	+0.1V	V			
	Detect V_{DD} voltage rang by user option, V_{SVS} $VLDx[3:0]=1101b$			3.6					
	Detect V_{DD} voltage rang by user option, V_{SVS} $VLDx[3:0]=1100b$			3.3					
	Detect V_{DD} voltage rang by user option, V_{SVS} $VLDx[3:0]=1011b$			3.0					
	Detect V_{DD} voltage rang by user option, V_{SVS} $VLDx[3:0]=1010b$			2.9					
	Detect V_{DD} voltage rang by user option, V_{SVS} $VLDx[3:0]=1001b$			2.8					
	Detect V_{DD} voltage rang by user option, V_{SVS} $VLDx[3:0]=1000b$			2.7					
	Detect V_{DD} voltage rang by user option, V_{SVS} $VLDx[3:0]=0111b$			2.6					
	Detect V_{DD} voltage rang by user option, V_{SVS} $VLDx[3:0]=0110b$			2.5					
	Detect V_{DD} voltage rang by user option, V_{SVS} $VLDx[3:0]=0101b$			2.4					
	Detect V_{DD} voltage rang by user option, V_{SVS} $VLDx[3:0]=0100b$			2.3					
	Detect V_{DD} voltage rang by user option, V_{SVS} $VLDx[3:0]=0011b$			2.2					
	Detect V_{DD} voltage rang by user option, V_{SVS} $VLDx[3:0]=0010b$			2.1					
	Detect V_{DD} voltage rang by user option, V_{SVS} $VLDx[3:0]=0001b$			2.0					
BOR : Brownout Reset LVR : Low Voltage Reset of BOR LVD : Low Voltage Detect RST : External Reset pin									

6.6. Power System

$T_A = 25^\circ\text{C}$, $V_{DD} = 3.0\text{V}$, unless otherwise noted

Sym.	Parameter	Test Conditions		Min.	Typ.	Max	unit	
VDDA	VDDA operation current, I_{VDDA}	$I_L = 0\text{mA}$	LDOC[2:0]=000b		12		μA	
	Select VDDA output voltage	$I_L = 0.1\text{mA}$, $V_{DD} \geq V_{VDDA} + 0.25\text{V}$	LDOC [2:0]=000b	-5%		+5%	2.4	V
			LDOC [2:0]=001b				2.6	V
			LDOC [2:0]=010b				2.9	V
			LDOC [2:0]=011b				3.3	V
			LDOC [2:0]=100b				3.6	V
			LDOC [2:0]=101b				4.0	V
			LDOC [2:0]=110b				4.5	V
			Dropout voltage				$I_L = 10\text{mA}$	LDOC [2:0]=000b
	Temperature drift	LDOC [2:0]=000b $I_L = 10\mu\text{A}$	$T_A = -40^\circ\text{C} \sim 85^\circ\text{C}$		50		ppm/ $^\circ\text{C}$	
V_{DD} Voltage drift	LDOC [2:0]=000b	$V_{DD} = 2.2\text{V} \sim 5.5\text{V}$		± 0.2		%/V		
VDDA : Adjust Voltage Regulator								

6.7. SD18, Power Supply and recommended operating conditions

$T_A = 25^\circ\text{C}$, $V_{DD} = 3.0\text{V}$, $V_{DDA}=2.4\text{V}$, unless otherwise noted

Sym.	Parameter	Test Conditions		Min.	Typ.	Max.	unit
V_{SD18}	Supply Voltage at VDDA	ENLDO[0]=0		2.4		4.5	V
f_{SD18}	Modulator sample frequency, ADC_CK			250	500		KHz
	Over Sample Ratio, OSR			64		65536	
I_{SD18}	Operation supply current without PGA	ENAD1 [0]=1	GAIN =16, ADC_CK= 500KHz		200		μA

6.7.1. PGA, Power Supply and recommended operating conditions

$T_A = 25^\circ\text{C}$, $V_{DD} = 3.0\text{V}$, $V_{DDA}=2.4\text{V}$, unless otherwise noted

Sym.	Parameter	Test Conditions		Min.	Typ.	Max.	unit
V_{PGA}	Supply Voltage at VDDA	ENLDO [0]=0		2.4		4.5	V
I_{PGA}	Operation supply current	PGAGN[1:0]=<11>			450		μA
G_{PGA}	Gain temperature drift	$T_A = -40^\circ\text{C} \sim 85^\circ\text{C}$	GAIN=128		15		$\text{ppm}/^\circ\text{C}$

6.7.2. SD18, performance

$T_A = 25^\circ\text{C}$, $V_{DD} = 3.6\text{V}$, $V_{DDA}=2.4\text{V}$, $V_{VR} = \text{AI2}(\text{short to VDDA})/2$, GAIN=16 with PGA=8, $f_{SD18}=500\text{KHz}$, unless otherwise noted

Sym.	Parameter	Test Conditions		Min.	Typ.	Max.	unit
INL	Integral Nonlinearity(INL)	$V_{DDA}=2.4\text{V}$, $V_{VR} = \text{AI2}/2$, $\Delta\text{SI}=\pm 200\text{mV}$			± 0.003	± 0.01	%FSR
		$V_{DDA}=2.4\text{V}$, $V_{VR} = \text{AI2}/2$, $\Delta\text{SI}=\pm 450\text{mV}$					
G_{SD18}	Temperature drift Gain x16	$T_A = -40^\circ\text{C} \sim 85^\circ\text{C}$			10		$\text{ppm}/^\circ\text{C}$
E_{OS}	Offset error of Full Scale Rang input voltage range with PGA=8	$\Delta\text{AI}=0\text{V}$ $\Delta\text{VR}=1.2\text{V}$	GAIN=16			1	%FSR
	Offset error temperature drift with PGA=8	DCSET[3:0]=<0000> * ΔAI is external short	GAIN=16		0.15		$\mu\text{V}/^\circ\text{C}$
CM_{SD18}	Common-mode rejection	$V_{CM}=0.7\text{V}$ to 1.7V , $V_{VR} = 1.0\text{V}$, without PGA	$V_{SI}=0\text{V}$, GAIN=16		75		dB
PSRR	DC power supply rejection	$V_{DDA}=3.0\text{V}$, $\Delta V_{DDA} = \pm 100\text{mV}$, $V_{VR}=1.0\text{V}$, $V_{SI}=1.2\text{V}$, $V_{SI-}=1.2\text{V}$,	GAIN=16 PGA=8		75		dB

6.7.3. SD18 Noise Performance

$T_A = 25^\circ\text{C}, V_{DD} = 3.0\text{V}, V_{DDA}=2.4\text{V}$, unless otherwise noted

HY15P43 針對 SD18 提供了重要的輸入雜訊規格。Table 6.8-3(a), Table 6.8-3(b) 列出典型的雜訊規格表與 Gain, Output rate, 及單端最大輸入電壓等關係。測試條件設定在外部輸入訊號短路，參考電壓為 1.2V，取樣 1024 筆資料。

<i>ENOB(RMS) with OSR/GAIN at A/D Clock=500KHz, VDDA=2.4V, VREF=1.2V</i>																
Max. Vin(mV) =0.9*VREF ⁽¹⁾	OSR					64	128	256	512	1024	2048	4096	8192	16384	32768	65536
	Output rate(HZ)					7813	3906	1953	977	488	244	122	61	31	15	8
	Gain	=	PGA	x	ADGN											
±67.5	16	=	1	x	16	9.50	13.96	14.92	15.48	16.03	16.50	16.98	17.49	17.91	18.38	18.87
±33.75	32	=	2	x	16	9.49	13.45	14.18	14.67	15.20	15.72	16.21	16.67	17.20	17.68	18.04
±16.875	64	=	4	x	16	9.49	13.14	13.87	14.34	14.85	15.27	15.84	16.31	16.79	17.33	17.75
±8.435	128	=	8	x	16	9.49	12.69	13.32	13.73	14.27	14.76	15.31	15.79	16.36	16.88	17.24

(1) Max. Vin (mV) is the max. input voltage of single end to ground (VSS).

Table 6.8-3(a) SD18 ENOB Table

<i>RMS Noise(uV) with OSR/GAIN at A/D Clock=500KHz, VDDA=2.4V, VREF=1.2V</i>																
Max. Vin(mV) =0.9*VREF	OSR					64	128	256	512	1024	2048	4096	8192	16384	32768	65536
	Output rate(HZ)					7813	3906	1953	977	488	244	122	61	31	15	8
	Gain	=	PGA	x	ADGN											
±67.5	16	=	1	x	16	207.05	9.42	4.84	3.28	2.25	1.62	1.16	0.82	0.61	0.44	0.31
±33.75	32	=	2	x	16	103.99	6.68	4.05	2.88	1.99	1.39	0.99	0.72	0.50	0.36	0.28
±16.875	64	=	4	x	16	51.99	4.15	2.51	1.81	1.27	0.95	0.64	0.46	0.33	0.23	0.17
±8.435	128	=	8	x	16	26.11	2.83	1.84	1.38	0.95	0.67	0.46	0.33	0.22	0.16	0.12

Table 6.8-3(b) SD18 RMS Noise Table

The RMS noise are referred to the input. The Effective Number of Bits (ENOB(RMS Bit)) is defined as:

$$ENOB(RMS) = \frac{\ln\left(\frac{FSR}{RMS\ Noise}\right)}{\ln(2)}$$

$$RMS\ Noise = \frac{\left(2 \times VREF \times \sqrt{\sum_{k=1}^{1024} (ADO[k] - Average)^2}\right)}{2^{23}}$$

Where FSR (Full - Scale Range) = $2 \times VREF / \text{Gain}$.

$$Average = \frac{\sum_{k=1}^{1024} (ADO[k])}{1024}$$

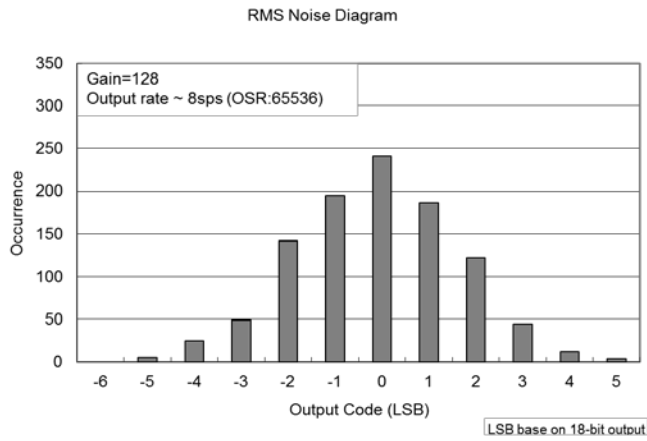

Figure6.8-3(a) RMS Noise Diagram

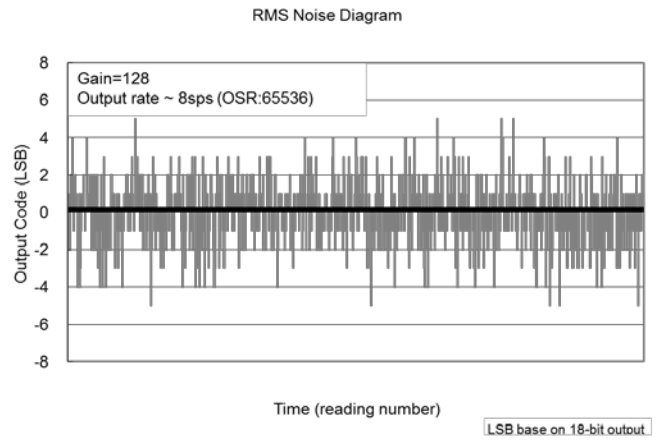

Figure6.8-3(b) Output Code Diagram

HY15P43

Embedded 18-Bit $\Sigma\Delta$ ADC

8-Bit RISC-like Mixed Signal Microcontroller

6.8. Build-In EPROM(BIE)

$T_A = 25^\circ\text{C}, V_{DD} = 3.0\text{V}$, unless otherwise noted

Sym.	Parameter	Test Conditions	Min.	Typ.	Max.	unit
V_{BIE}	Supply Voltage at VPP PIN			8.5	8.75	V
I_{BIE}	Operation supply current			3		mA
V_{SS}	Supply Voltage			0		V

When connecting to the external V_{BIE} power source to program the BIE block, users can use the instruction to program the words one by one into the BIE block.

6.9. Build-In EPROM(BIE) Low voltage control circuit

$T_A = 25^\circ\text{C}, V_{DD} = 3.05\text{V}$, unless otherwise noted

Sym.	Parameter	Test Conditions	Min.	Typ.	Max.	unit
T_O	Operation temperature range		0	25	40	$^\circ\text{C}$
V_{DD}	Operation supply Voltage		2.75		5.5	V
V_{SS}	Supply Voltage			0		V

When the 2.75V low voltage programming control circuit is activated, users can program the BIE block without connecting to the external V_{BIE} power source.



圖 6-1 BIE typical application 方塊圖



圖 6-2 BIE typical application use low voltage control circuit 方塊圖

HY15P43

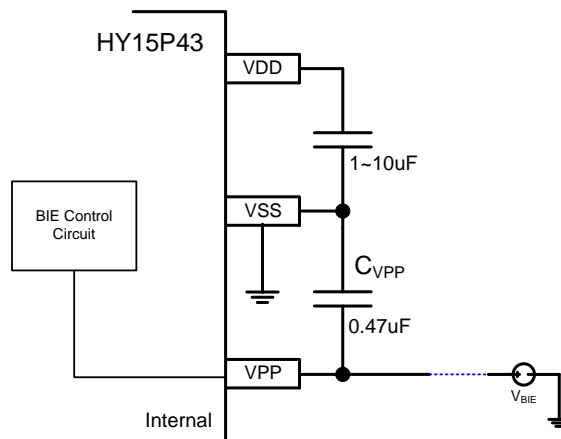
Embedded 18-Bit Σ ADC

8-Bit RISC-like Mixed Signal Microcontroller

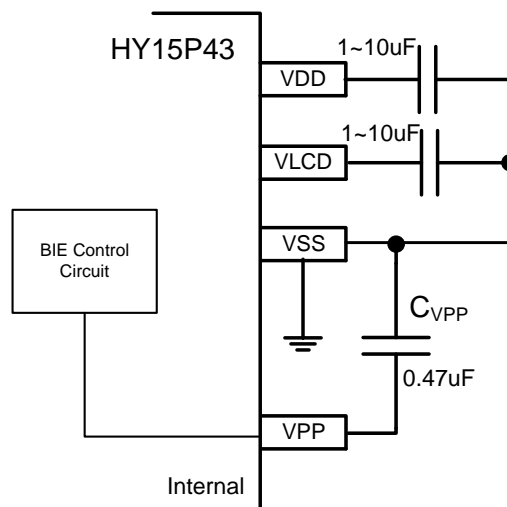
7. 訂貨資訊

下單品名 ¹	封裝型式	引腳數	封裝型式		程式碼	出貨包裝 形式	個裝 數量	材料 組成	MSL ³
			描述方式		編號 ²				
HY15P43-D000	Die	-	D	000	000	-	250	Green ⁴	-
HY15P43-T028	TSSOP	28	T	028	000	Tube	50	Green ⁴	MSL-3
HY15P43-T028	TSSOP	28	T	028	000	Tape & Reel	4000	Green ⁴	MSL-3
HY15P43-L048	LQFP	48	L	048	000	Tray	250	Green ⁴	MSL-3

¹ 產品名稱 - 封裝型式描述方式 - 程式碼編號 (空白片 / 標準品 / 代客燒錄碼)

例如：您的 HY15P43 代客燒錄服務申請的程式碼編號為 008，且需要的產品是裸片出貨。則下單品名為 HY15P43-D000-008

例如：您的需求是 HY15P43 不帶程式碼的空白片且需要的產品是裸片出貨。則下單品名為 HY15P43-D000

例如：您的需求是 HY15P43 不帶程式碼的空白片且需要的產品是封裝片 LQFP 7x7 48L 出貨，則下單品名為 HY15P43-L048，且需以 Tray 出貨，則除下單品名外，請特別註明出貨包裝形式為 Tray

例如：您的 HY15P43 代客燒錄服務申請的程式碼編號為 009，而需求的產品是封裝片 TSSOP 出貨，則下單品名為 HY15P43-T028-009，且需以 Tape & Reel 出貨，則除下單品名外，請特別註明出貨包裝形式為 Tape & Reel

² 程式碼編號

“001”~“999” 為標準品或代客燒錄申請的程式碼編號，而空白晶片不帶此碼。

³ MSL:

濕度敏感性等級係依據 IPC/JEDEC J-STD-020 的規範加以試驗分級，並參考 IPC/JEDEC J-STD-033 的標準處理、包裝、運輸與使用。

⁴ Green (RoHS & no Cl/Br):

HYCON 產品皆為 Green Product，符合 RoHS 指令以及無鹵素規定。

HY15P43

Embedded 18-Bit Σ ADC

8-Bit RISC-like Mixed Signal Microcontroller

8. 封裝型式資訊

8.1. LQFP 7x7 48L(L048)

8.1.1. Package Dimensions

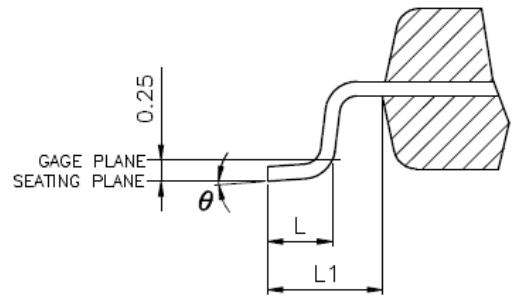
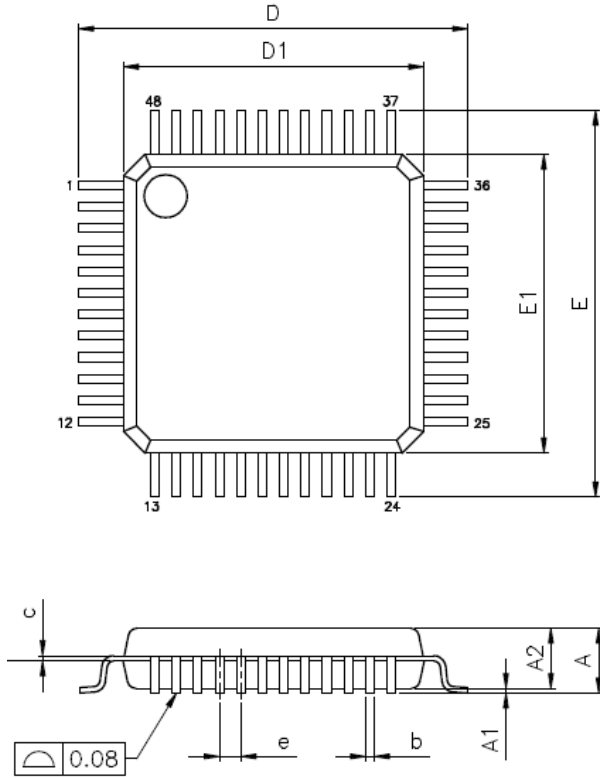

SYMBOLS	MIN.	NOM.	MAX.
A	--	--	1.60
A1	0.05	--	0.15
A2	1.35	1.40	1.45
b	0.17	0.22	0.27
c	0.09	--	0.20
D	9.00 BSC		
D1	7.00 BSC		
E	9.00 BSC		
E1	7.00 BSC		
e	0.50 BSC		
L	0.45	0.60	0.75
L1	1.00 REF		
θ	0°	3.5°	7°

Note:

1. All dimensions refer to JEDEC OUTLINE MS-012.
2. Do not include Mold Flash or Protrusions.
3. Unit: mm.

HY15P43

Embedded 18-Bit $\Sigma\Delta$ ADC

8-Bit RISC-like Mixed Signal Microcontroller

8.2. TSSOP28(T028)

8.2.1. Package Dimensions

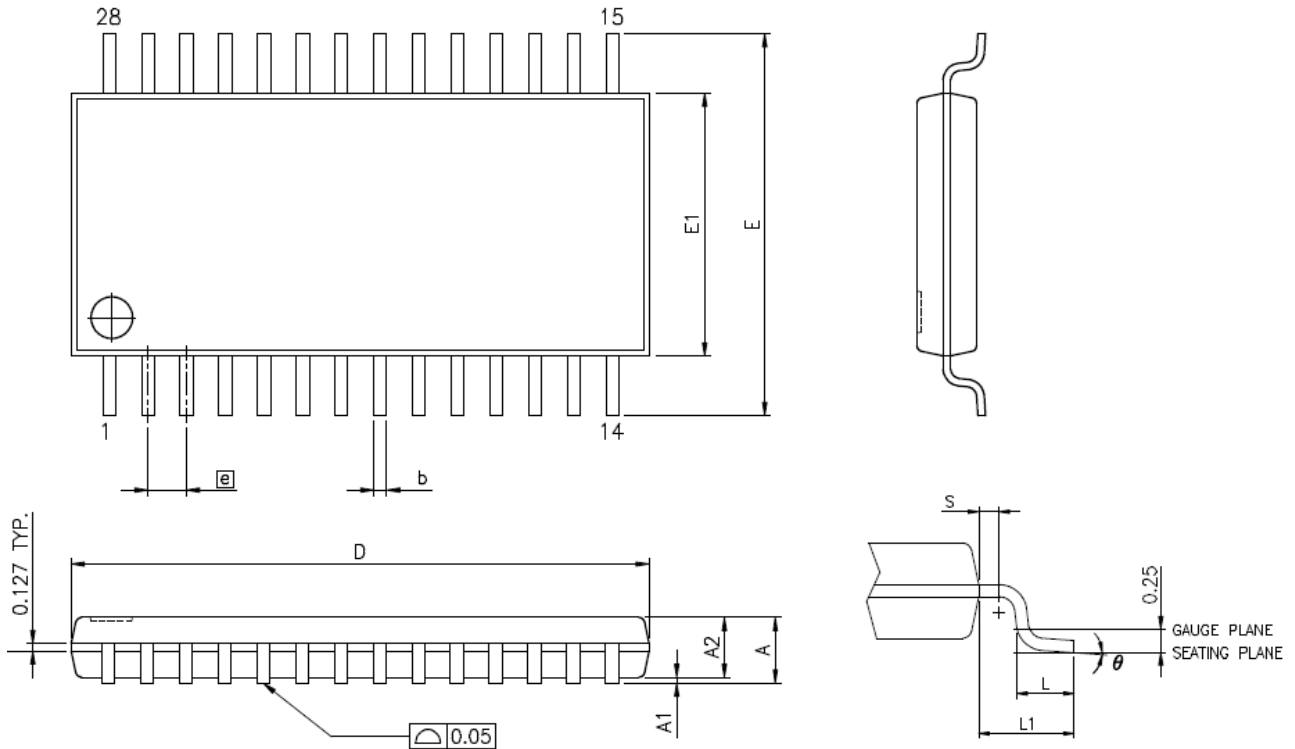

SYMBOLS	MIN.	NOM.	MAX.
A	—	—	1.20
A1	0.00	—	0.15
A2	0.80	1.00	1.05
b	0.19	—	0.30
D	9.60	9.70	9.80
E1	4.30	4.40	4.50
E	6.40 BSC		
e	0.65 BSC		
L1	1.00 REF		
L	0.45	0.60	0.75
S	0.20	—	—
θ	0°	—	8°

Note:

1. All dimensions refer to JEDEC OUTLINE MO-153.
2. Do not include Mold Flash or Protrusions.
3. Unit: mm.

HY15P43

Embedded 18-Bit Σ ADC

8-Bit RISC-like Mixed Signal Microcontroller

8.2.2. Tube Information

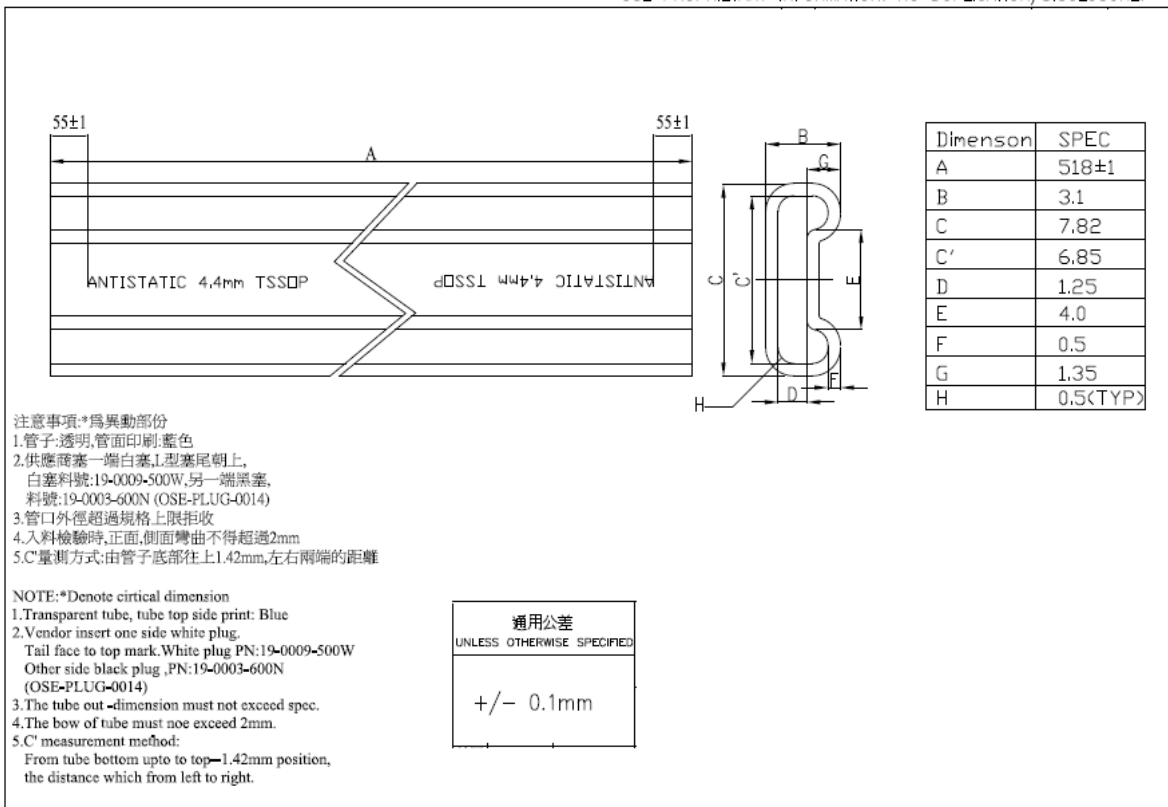
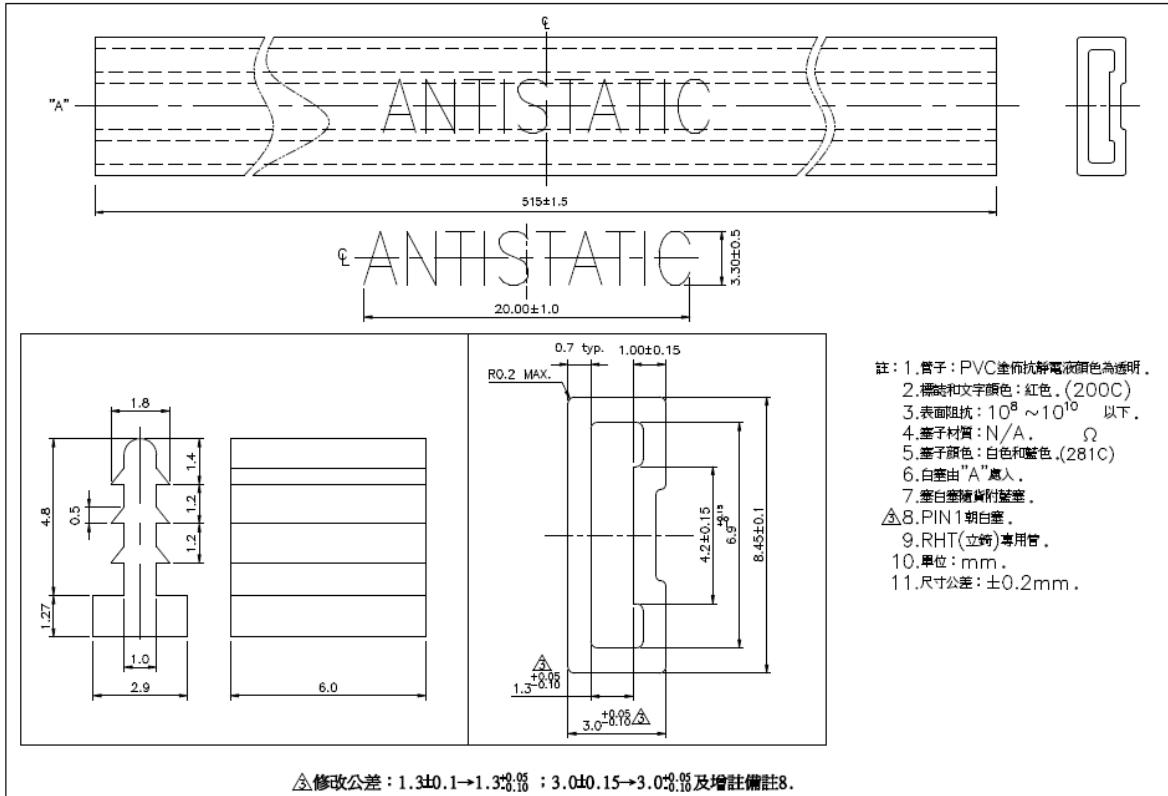

HY15P43

Embedded 18-Bit $\Sigma\Delta$ ADC

8-Bit RISC-like Mixed Signal Microcontroller

8.2.3. Tape & Reel Information

8.2.3.1. Reel Dimensions

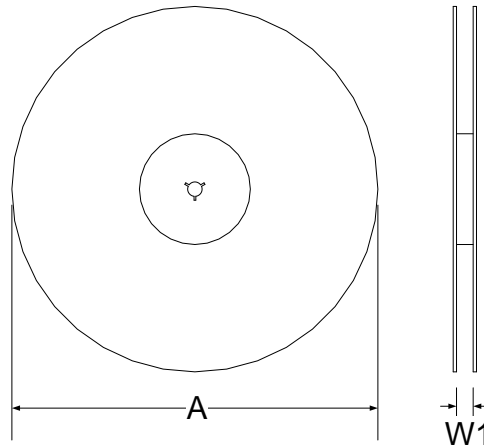

8.2.3.2. Carrier Tape Dimensions

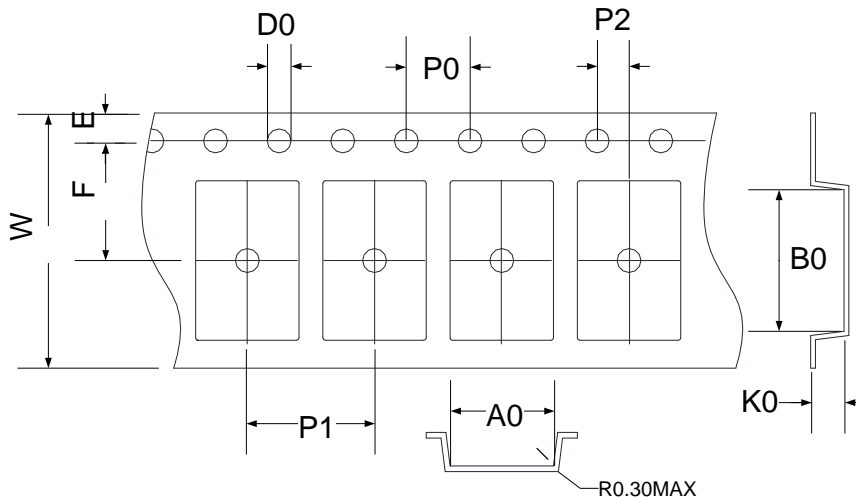

SYMBOLS	Reel Dimensions		Carrier Tape Dimensions									
	A	W1	A0	B0	K0	P0	P1	P2	E	F	D0	W
Spec.	330	16.5	6.80	10.20	1.60	4.00	8.00	2.00	1.75	7.50	1.50	16.00
Tolerance	+6/-3	+1.5/-0	±0.10	±0.10	±0.10	±0.10	±0.10	±0.10	±0.10	±0.10	+0.1/-0	±0.30

Unit : mm

Note: 10 Sprocket hole pitch cumulative tolerance is ± 0.20 mm.

8.2.3.3. Pin1 direction

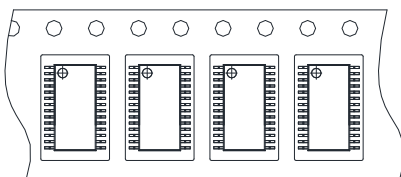

HY15P43

Embedded 18-Bit $\Sigma\Delta$ ADC

8-Bit RISC-like Mixed Signal Microcontroller



9. 附錄 A

9.1. HY15P 系列產品差異比較表

ITEM	HY15P43	HY15P53
Display Mode	LED Mode only	LCD/LED Mode
COM port, sink current (VDD=4V)	40mA	20mA

10. 修訂記錄

以下描述本文件差異較大的地方，而標點符號與字形的改變不在此描述範圍。

版本	頁數	變更摘要	修訂日期
V01	ALL	初版發行	2016/03/30
V02	7	修改 TSSOP28 引腳圖	2016/06/30
	8 ~ 10	修改 TSSOP28 引腳定義與說明	
V03	P15, P17	1. 統一「LCD 倍壓電路控制器」名稱為 ENLCP。 2. 統一「SD18 啓用控制器」名稱為 ENAD1。	2016/08/12
	P17, P29	1. VREGN 只能設為 0b = x1。 2. VRH 只能設為 0b = A12。	
	P23	統一「電源干擾復位旗標」名稱為 BOR。	